

---

---

**Earth-moving machinery —  
Determination of sound power level —  
Stationary test conditions**

*Engins de terrassement — Détermination du niveau de puissance  
acoustique — Conditions d'essai statique*



Reference number  
ISO 6393:2008(E)

© ISO 2008

**PDF disclaimer**

This PDF file may contain embedded typefaces. In accordance with Adobe's licensing policy, this file may be printed or viewed but shall not be edited unless the typefaces which are embedded are licensed to and installed on the computer performing the editing. In downloading this file, parties accept therein the responsibility of not infringing Adobe's licensing policy. The ISO Central Secretariat accepts no liability in this area.

Adobe is a trademark of Adobe Systems Incorporated.

Details of the software products used to create this PDF file can be found in the General Info relative to the file; the PDF-creation parameters were optimized for printing. Every care has been taken to ensure that the file is suitable for use by ISO member bodies. In the unlikely event that a problem relating to it is found, please inform the Central Secretariat at the address given below.



**COPYRIGHT PROTECTED DOCUMENT**

© ISO 2008

All rights reserved. Unless otherwise specified, no part of this publication may be reproduced or utilized in any form or by any means, electronic or mechanical, including photocopying and microfilm, without permission in writing from either ISO at the address below or ISO's member body in the country of the requester.

ISO copyright office  
Case postale 56 • CH-1211 Geneva 20  
Tel. + 41 22 749 01 11  
Fax + 41 22 749 09 47  
E-mail [copyright@iso.org](mailto:copyright@iso.org)  
Web [www.iso.org](http://www.iso.org)

Published in Switzerland

# Contents

Page

Foreword.....	iv
Introduction .....	v
1 Scope .....	1
2 Normative references .....	1
3 Terms and definitions.....	1
4 Instrumentation.....	2
5 Test environment.....	2
5.1 General.....	2
5.2 Test site and environmental correction, $K_{2A}$ .....	2
5.3 Test site .....	3
5.4 Background noise correction, $K_{1A}$ .....	3
5.5 Climatic conditions.....	4
6 Measurement of time-averaged A-weighted sound pressure levels .....	4
6.1 Size of measurement surface .....	4
6.2 Microphone positions on the hemispherical measurement surface.....	4
6.3 Positioning the machine .....	5
6.4 Measurement time .....	6
7 Setting-up and operation of machinery.....	6
7.1 General.....	6
7.2 Engine speed.....	6
7.3 Fan speed .....	6
8 Determination of A-weighted sound power level .....	7
8.1 Measurement procedure .....	7
8.2 Calculation of A-weighted sound power level .....	7
8.3 Determination of measurement result.....	8
9 Information to be recorded .....	8
10 Information to be reported .....	9
10.1 Information .....	9
10.2 Declaration of sound emission data and uncertainty.....	9
Annex A (normative) Basic length, $l$ , and additional machine specifications .....	10
Annex B (normative) Declaration of sound emission data and uncertainty .....	22
Bibliography .....	23

## Foreword

ISO (the International Organization for Standardization) is a worldwide federation of national standards bodies (ISO member bodies). The work of preparing International Standards is normally carried out through ISO technical committees. Each member body interested in a subject for which a technical committee has been established has the right to be represented on that committee. International organizations, governmental and non-governmental, in liaison with ISO, also take part in the work. ISO collaborates closely with the International Electrotechnical Commission (IEC) on all matters of electrotechnical standardization.

International Standards are drafted in accordance with the rules given in the ISO/IEC Directives, Part 2.

The main task of technical committees is to prepare International Standards. Draft International Standards adopted by the technical committees are circulated to the member bodies for voting. Publication as an International Standard requires approval by at least 75 % of the member bodies casting a vote.

Attention is drawn to the possibility that some of the elements of this document may be the subject of patent rights. ISO shall not be held responsible for identifying any or all such patent rights.

ISO 6393 was prepared by Technical Committee ISO/TC 127, *Earth-moving machinery*, Subcommittee SC 2, *Safety requirements and human factors*, in collaboration with Technical Committee ISO/TC 43, *Acoustics*, Subcommittee SC 1, *Noise*.

This third edition cancels and replaces the second edition (ISO 6393:1998), which has been technically revised.

## Introduction

This International Standard is a specific test code for earth-moving machinery as defined in ISO 6165.

Specific procedures are described in this International Standard to enable the sound power emission in stationary test conditions to be determined in a manner which is repeatable. Attachments (bucket, dozer, etc.) for the manufacturer's production version are intended to be fitted since this is the configuration most likely to exist when the machine is in actual use.

This International Standard enables compliance with noise limits to be determined. It can also be used for evaluation purposes in noise reduction investigations.

A complementary test code is given in ISO 6394. This other specific test code is intended to be used to determine the noise emitted by earth-moving machinery, measured at the operator's position in terms of the A-weighted sound pressure level, with the machine under stationary test conditions.

Corresponding measurements of noise emitted to the environment and noise at the operator's position under dynamic test conditions are described in ISO 6395 and ISO 6396 respectively.



# Earth-moving machinery — Determination of sound power level — Stationary test conditions

## 1 Scope

This International Standard specifies a method for determining the noise emitted to the environment by earth-moving machinery, measured in terms of the A-weighted sound power level while the machine is stationary and with the engine operating at the rated speed under no-load conditions.

It is applicable to earth-moving machinery as specified in Annex A and as defined in ISO 6165.

## 2 Normative references

The following referenced documents are indispensable for the application of this document. For dated references, only the edition cited applies. For undated references, the latest edition of the referenced document (including any amendments) applies.

ISO 3744:—<sup>1)</sup>, *Acoustics — Determination of sound power levels and sound energy levels of noise sources using sound pressure — Engineering method for an essentially free field over a reflecting plane*

ISO 6165, *Earth-moving machinery — Basic types — Identification and terms and definitions*

ISO 9249, *Earth-moving machinery — Engine test code — Net power*

IEC 61672-1, *Electroacoustics — Sound level meters — Part 1: Specifications*

## 3 Terms and definitions

For the purposes of this document, the terms and definitions given in ISO 3744 and ISO 6165, and the following, apply.

### 3.1

#### time-averaged A-weighted sound pressure level

$L_{pA,T}$

A-weighted sound pressure level averaged on an energy basis over the whole measurement period,  $T$

### 3.2

#### A-weighted sound power level

$L_{WA}$

quantity obtained from the time-averaged A-weighted sound pressure levels averaged over the measurement surface on an energy basis

1) To be published. (Revision of ISO 3744:1994.)

**3.3  
basic length**

*l*

length used to define the radius of the measurement hemisphere

NOTE The dimension of the basic length, *l*, is determined in Annex A.

**3.4 Machine centre point**

**3.4.1  
machine centre point**

⟨all machines, except those with slewing upper structure⟩ midpoint of the basic length, *l*, at the machine longitudinal centreline

**3.4.2  
machine centre point**

⟨machines with slewing upper structure⟩ centre of rotation of the upper structure

**3.5 Fan speed**

**3.5.1  
maximum working speed of the fan**

fan speed at which the fan provides maximum cooling performance for the machine under the most severe operating conditions

**3.5.2  
fan drive with continuous variable fan speed**

fan drive that varies the fan speed continuously throughout a variable range to minimize its speed for the needed cooling performance in relation to the heat load

**4 Instrumentation**

The instrumentation shall be capable of carrying out the measurements according to Clause 8. The preferred instrumentation system for acquiring the data is an integrating-averaging sound level meter complying with the requirements of IEC 61672-1 for a class 1 instrument.

**5 Test environment**

**5.1 General**

For the purposes of this International Standard, the test environment specified in ISO 3744:—, Clause 4 and Annex A, apply. Additional requirements are given in 5.2 to 5.5.

Humidity, air temperature, barometric pressure, vibration and stray magnetic fields shall be within the limits specified by the manufacturer of the instrumentation.

**5.2 Test site and environmental correction,  $K_{2A}$**

For test-site measurement ground surfaces consisting of a hard reflecting plane — such as concrete or non-porous asphalt [5.3.1 a) and b)] — and having negligible sound-reflecting obstacles within a distance from the source equal to three times the measurement hemisphere radius, it may be assumed that the absolute value of environmental correction,  $K_{2A}$ , is less than or equal to 0,5 dB and can therefore be disregarded.

For the all-sand test site [5.3.1 c)], the value of environmental correction,  $K_{2A}$ , shall be determined and used in the sound power calculation.



## 5.3 Test site

### 5.3.1 General

The following three types of test-site measurement ground surface, described in 5.3.2, 5.3.3 and 5.3.4, are allowed:

- a) hard reflecting plane (concrete or non-porous asphalt);
- b) combination of hard reflecting plane and sand;
- c) all-sand plane.

The hard reflecting plane, as described in 5.3.2, shall be used for the stationary measurement of all machines.

The combination of hard reflecting plane and sand, as described in 5.3.3, may be used for rollers with raised pads and landfill compactors.

The combination of hard reflecting plane and sand, as described in 5.3.3, or the all-sand plane, as described in 5.3.4, may be used for crawler-type machines, except crawler-type excavators, provided that

- the environmental correction,  $K_{2A}$ , determined in accordance with ISO 3744:—, Annex A, is less than 2,0 dB, and
- for the all-sand plane as described in 5.3.4, where  $K_{2A}$  is greater than 0,5 dB, the correction is accounted for in the calculation of the sound power level.

### 5.3.2 Hard reflecting plane

The test area bordered by the vertical projection of the microphones to the ground shall consist of concrete or non-porous asphalt.

### 5.3.3 Combination of hard reflecting plane and sand

The test site for the machine shall consist of humid sand of grain size up to 2 mm. The minimum depth of the sand shall be 0,3 m. If 0,3 m is not deep enough for track penetration, the depth shall be increased accordingly. The ground surface between the machine and the microphones shall be a hard reflecting plane, as described in 5.3.2.

It is possible to use a combination site of minimum size comprising only a single reflecting plane with a sand path along the side. In this case, a set of measurements with three microphones shall be carried out on one side of the machine. Another set shall then be carried out for the other side after turning the machine 180°.

### 5.3.4 All-sand plane

The sand shall be as specified in 5.3.3.

## 5.4 Background noise correction, $K_{1A}$

The requirements for background noise, as specified in ISO 3744, shall be fulfilled. Corrections for background noise shall be made as specified in ISO 3744:—, 8.3.2.

## 5.5 Climatic conditions

Measurements shall not be carried out under the following conditions:

- a) when there is precipitation, i.e. rain, snow or hail;
- b) when the ground surface is covered with snow;
- c) when the temperature is below  $-10\text{ °C}$  or above  $+35\text{ °C}$ ;
- d) when wind speed exceeds 8 m/s; for wind speeds in excess of 1 m/s, a microphone windscreen shall be used, and appropriate compensation for the effect of its use shall be allowed for when calibrating.

## 6 Measurement of time-averaged A-weighted sound pressure levels

### 6.1 Size of measurement surface

The measurement surface to be used for the test shall be a hemisphere. The radius of the hemisphere shall be determined by the basic length,  $l$ , of the machine as specified in Annex A. The basic length includes the main body of the machine and excludes major attachments, such as dozer blades, bucket and boom.

The radius shall be

- 4 m when the basic length,  $l$ , of the machine to be tested is less than 1,5 m,
- 10 m when the basic length,  $l$ , of the machine to be tested is greater than or equal to 1,5 m but less than 4 m,
- 16 m when the basic length,  $l$ , of the machine to be tested is greater than or equal to 4 m but less than 8 m, and
- the smallest radius of the sequence, 16 m, 18 m, 20 m... when the basic length,  $l$ , of the machine to be tested is greater than 8 m and the hemisphere radius exceeds twice the characteristic length,  $d_0$ , of the machine to be tested.

NOTE Characteristic length,  $d_0$ , is as defined in ISO 3744, with the machine length,  $l$ , equal to  $l_1$ .

### 6.2 Microphone positions on the hemispherical measurement surface

Six measuring positions shall be used. Microphone positions and their coordinates shall be as shown in Figure 1 and as given in Table 1.

Dimensions in metres

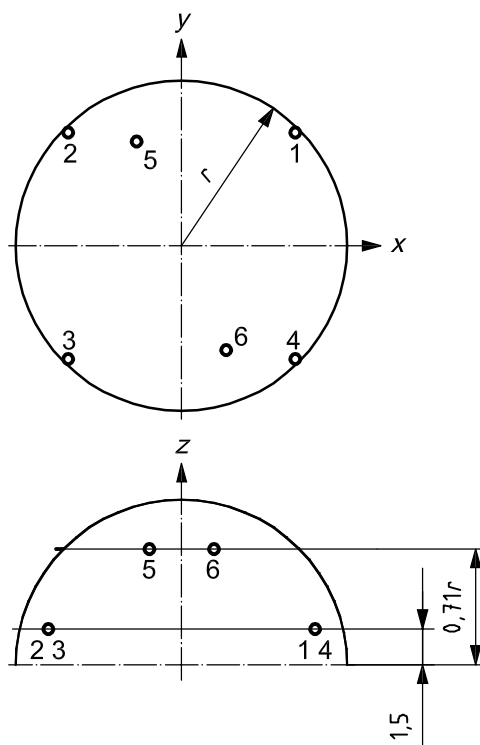
**Key**

- 1 to 6 microphone positions  
 $r$  hemisphere radius

**Figure 1 — Microphone array on the hemisphere****Table 1 — Co-ordinates for microphone positions**

Microphone position	$x/r$	$y/r$	$z$
1	0,7	0,7	1,5 m
2	-0,7	0,7	1,5 m
3	-0,7	-0,7	1,5 m
4	0,7	-0,7	1,5 m
5	-0,27	0,65	0,71 $r$
6	0,27	-0,65	0,71 $r$

**6.3 Positioning the machine****6.3.1 All machines, except those with slewing upper structure**

The machine centre point shall be approximately vertical above the hemisphere centre point, which is the intersection of the  $x$ - and  $y$ -axes shown in Figure 1. The front of the machine shall face microphone positions 1 and 4. The midpoint of the basic length,  $l$  (see Annex A), is the machine centre point for positioning purposes.

### 6.3.2 Machines with slewing upper structure

The machine centre point shall be approximately vertical above the hemisphere centre point, which is the intersection of the  $x$ - and  $y$ -axes shown in Figure 1. The front of the machine shall face microphone positions 1 and 4. The centre of rotation of the upper structure is the machine centre point for positioning purposes.

### 6.4 Measurement time

The total measurement time for each reading at each measurement position in a stabilized operating mode shall be in the range of 15 s to 30 s.

## 7 Setting-up and operation of machinery

### 7.1 General

#### 7.1.1 Safety and operation

All relevant safety precautions and the manufacturer's operating instructions shall be followed during the test.

#### 7.1.2 Machine set-up

The machine shall be equipped with the equipment and attachment(s) specified by the manufacturer. The engine and hydraulic system shall be warmed to normal operating conditions as specified by the machine manufacturer.

All liquid systems shall be filled within the range specified by the manufacturer.

The machine shall be placed on the test site with the attachments positioned at a height of  $300 \text{ mm} \pm 50 \text{ mm}$  above the ground or at their maximum height, if this is less than 250 mm. The plane formed by the edges of the attachment shall be approximately parallel to the ground (transport position).

#### 7.1.3 Machine operation conditions

The machine shall be stationary and the brakes applied. The engine shall be operated in a no-load condition at the manufacturer's specified speed corresponding to the engine net power in accordance with ISO 9249. The transmission shall be in neutral, and auxiliary or prime attachments shall not be in operation. Test data shall not be taken until a stabilized operating temperature for the prevailing ambient conditions has been attained. The operator shall remain at the machine controls throughout the test.

### 7.2 Engine speed

The engine shall be brought first to a low idle condition and then up to the manufacturer's specified rated speed at a stabilized no-load condition prior to each data-taking sequence.

### 7.3 Fan speed

If the engine of the machine or its hydraulic system is fitted with fan(s), they shall operate during the test. The fan speed shall be in accordance with one of the following conditions, stated and set by the manufacturer of the machine.

#### a) Fan drive directly connected to the engine

If the fan drive is directly connected to the engine and/or hydraulic equipment (e.g. by belt drive), it shall operate during the test.

**b) Fan drive with several distinct speeds**

If the fan can work at several distinct speeds, the test shall be carried out

- either at the maximum working speed of the fan, or
- in a first test with the fan set at zero speed and in a second test with the fan set at maximum working speed; the resulting time-averaged A-weighted sound pressure level,  $L_{pA,T}$ , shall be then calculated by combining both test results using Equation (1):

$$L_{pA,T} = 10 \lg \left( 0,3 \times 10^{0,1L_{pA,0\%}} + 0,7 \times 10^{0,1L_{pA,100\%}} \right) \text{ dB} \quad (1)$$

where

$L_{pA,0\%}$  is the time-averaged A-weighted sound pressure level determined with the fan set at zero speed;

$L_{pA,100\%}$  is the time-averaged A-weighted sound pressure level determined with the fan set at maximum speed.

**c) Fan drive with continuously variable speed**

If the fan can work at continuous variable speed, the test shall be carried out either in accordance with 7.3 b) or with the fan speed set by the manufacturer at no less than 70 % of the maximum working speed.

**d) Machine equipped with more than one fan**

All fans shall run at the conditions specified in a), b) or c).

**8 Determination of A-weighted sound power level****8.1 Measurement procedure**

The A-weighted sound power level shall be determined in accordance with ISO 3744.

At least three sets of measurements shall be carried out, with the operating conditions in accordance with Clause 7.

**8.2 Calculation of A-weighted sound power level**

The A-weighted sound power level,  $L_{WA}$ , in decibels, of the machinery shall be calculated using Equation (2):

$$L_{WA} = \overline{L_{pA,T}} - K_{1A} - K_{2A} + 10 \lg \left( \frac{S}{S_0} \right) \text{ dB} \quad (2)$$

where

$\overline{L_{pA,T}}$  is the energy-average of the time-averaged A-weighted sound pressure levels on the measurement surface, in decibels, with

$$\overline{L_{pA,T}} = 10 \lg \left[ \frac{1}{N} \sum_{i=1}^N 10^{0,1L_{pA,i}} \right] \text{ dB} \quad (3)$$

where

$L_{pA,i}$  is the time-averaged A-weighted sound pressure level resulting from the microphone position  $i$ , in decibels (reference: 20  $\mu$ Pa);

$N$  is the total number of microphone positions ( $N = 6$ );

$K_{1A}$  is the background noise correction (see 5.4);

$K_{2A}$  is the environmental correction (see 5.2 and 5.3.1);

$S$  is the area of the hemispherical measurement surface, in square metres, i.e.  $S = 2\pi r^2$ ;

$S_0 = 1 \text{ m}^2$ ;

$10 \lg \left( \frac{S}{S_0} \right) = 20,0 \text{ dB}$  for a 4 m radius, 28,0 dB for a 10 m radius and 32,1 dB for a 16 m radius.

All intermediate results, such as sound pressure levels and area calculations, shall be expressed to one decimal place.

### 8.3 Determination of measurement result

Calculate the three A-weighted values of the sound power level from the three sets of data obtained at each microphone position (see 8.1).

If two of the three values so obtained do not differ by more than 1 dB, further measurements are unnecessary. If this is not the case, continue taking measurements until two values within 1 dB of one another are obtained. The A-weighted sound power level to be reported is the arithmetic mean of the two highest values that are within a 1 dB range of each other.

## 9 Information to be recorded

The following information, as applicable, shall be compiled and recorded for all measurements made in accordance with this International Standard.

### a) Machinery under test:

- machine manufacturer;
- machine model number;
- machine serial number;
- type of fan-drive system(s), test method(s) used, as specified in 7.3 a), b) or c), including corresponding system maximum fan speed and fan speed(s) used during the test for each fan;
- machine arrangement, including major equipment and attachments, and engine speed specified by the manufacturer, corresponding to the speed at which the engine develops its net power in accordance with ISO 9249;
- engine net power, in kilowatts, at corresponding speed, as defined in ISO 9249.

### b) Acoustic environment:

- description of test site and type of test-site measurement ground surface used, including a sketch showing the position of the machine;
- air temperature, barometric pressure, relative humidity and wind velocity at the test site.

**c) Instrumentation:**

- instrumentation used for the acoustical measurements, including name, type, serial number and manufacturer;
- method used to calibrate the instrumentation system;
- date and place of calibration of the acoustical calibrator and the instrumentation system.

**d) Acoustical data:**

- location of the microphones;
- time-averaged A-weighted sound pressure level at each microphone position for each measurement conducted in accordance with 8.1;
- time-averaged A-weighted sound pressure level of the background noise at each microphone position;
- time-averaged A-weighted sound pressure level averaged over the measurement surface, calculated in accordance with 8.2;
- final value of the A-weighted sound power level calculated in accordance with 8.2 and determined in accordance with 8.3.

**10 Information to be reported****10.1 Information**

The following information shall be reported:

- a) machine manufacturer, model number, serial number, engine net power (in kilowatts, at rated speed, as defined in ISO 9249), machine arrangement, including major attachments, and the type of test site measurement ground surface used;
- b) A-weighted sound power level, determined in accordance with 8.3, rounded to the nearest whole number (use the lower number for values  $< 0,5$ ; use the higher number for values  $\geq 0,5$ );
- c) manufacturer's specified engine speed, corresponding to the speed at which the engine develops its net power, in accordance with ISO 9249;
- d) type of fan-drive system(s), test method(s) used as specified in 7.3 a), b) or c), including corresponding system maximum fan speed and fan speed(s) used during the test for each fan;
- e) level of the fuel tank and, if applicable, level of the sprinkler water tank(s) and ballast compartment(s).

**10.2 Declaration of sound emission data and uncertainty**

In some markets, the additional requirements listed in the normative Annex B apply. The declaration of sound emission data and uncertainty shall be made in accordance with Annex B, if relevant.

## Annex A (normative)

### Basic length, $l$ , and additional machine specifications

#### A.1 Dozer

##### A.1.1 Crawler dozer

See Figure A.1.

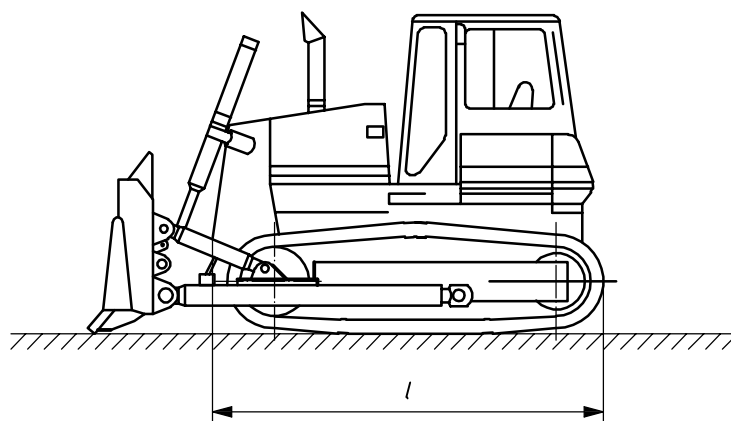

Figure A.1

##### A.1.2 Wheeled dozer

See Figure A.2.

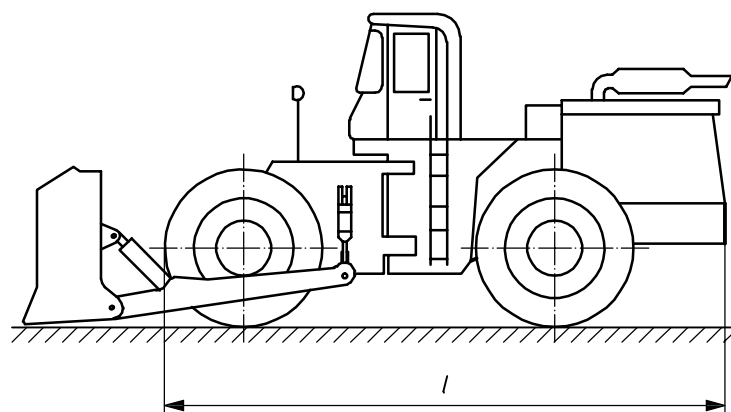

Figure A.2



## A.2 Loader

### A.2.1 Wheeled loader

Wheeled loader with an operating mass  $> 4\,500$  kg. See Figure A.3.

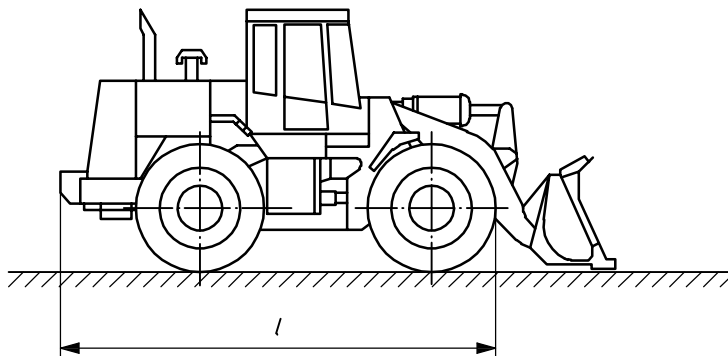

Figure A.3

### A.2.2 Compact loader, wheeled

Wheeled loader with an operating mass  $\leq 4\,500$  kg. See Figure A.4.

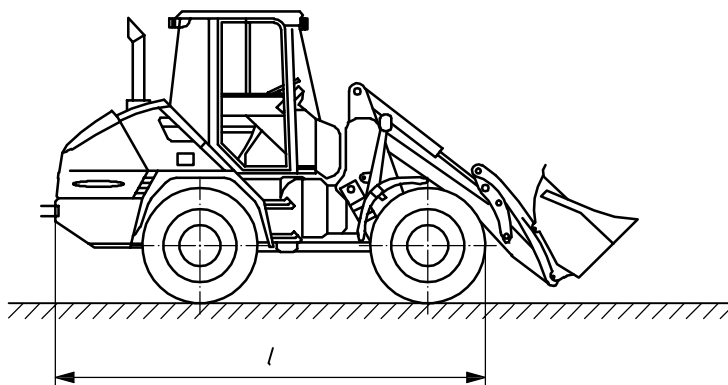

Figure A.4

### A.2.3 Crawler loader

See Figure A.5.

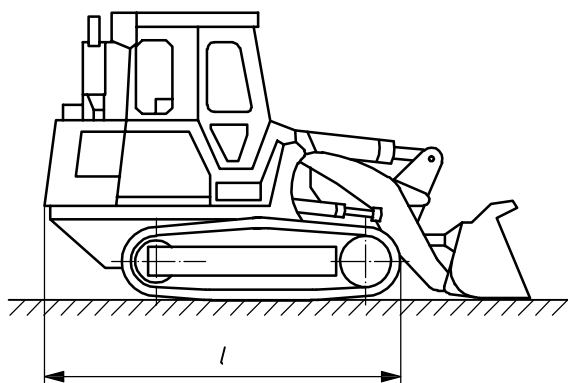

Figure A.5

### A.2.4 Skid steer loader

See Figure A.6.

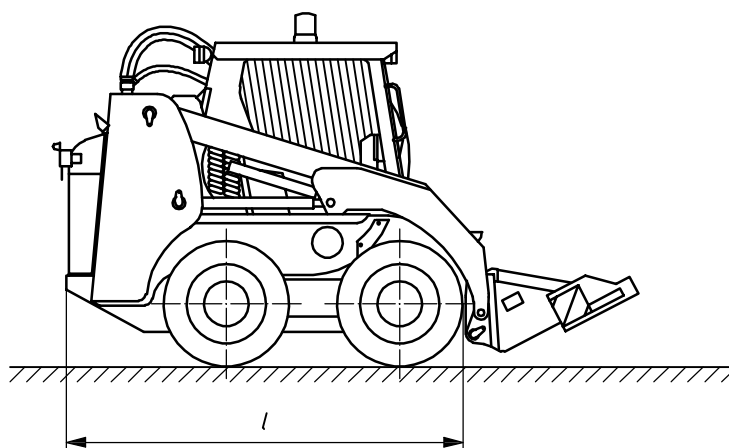

Figure A.6

### A.3 Backhoe loader

#### A.3.1 Wheeled backhoe loader

See Figure A.7.

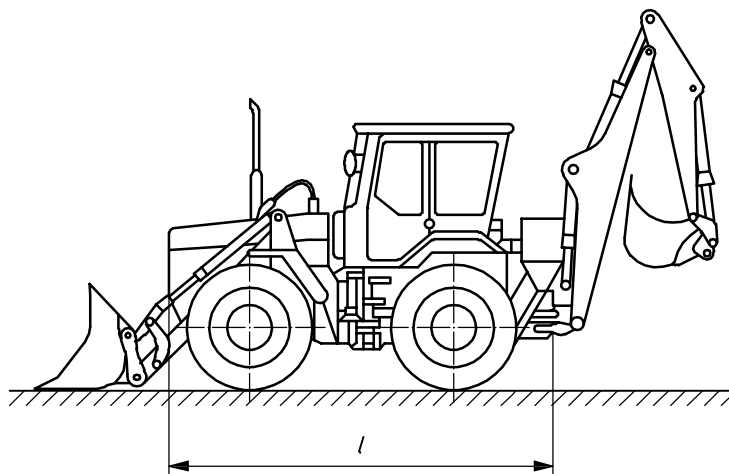

Figure A.7

#### A.3.2 Crawler backhoe loader

See Figure A.8.

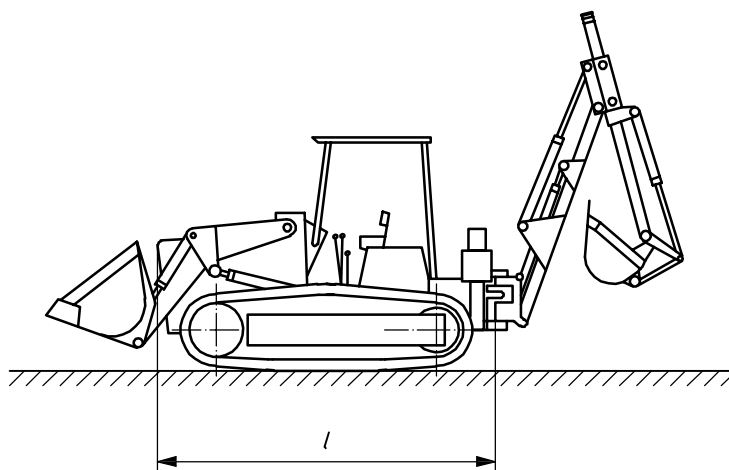

Figure A.8

## A.4 Excavators

### A.4.1 Wheeled excavator

See Figure A.9.

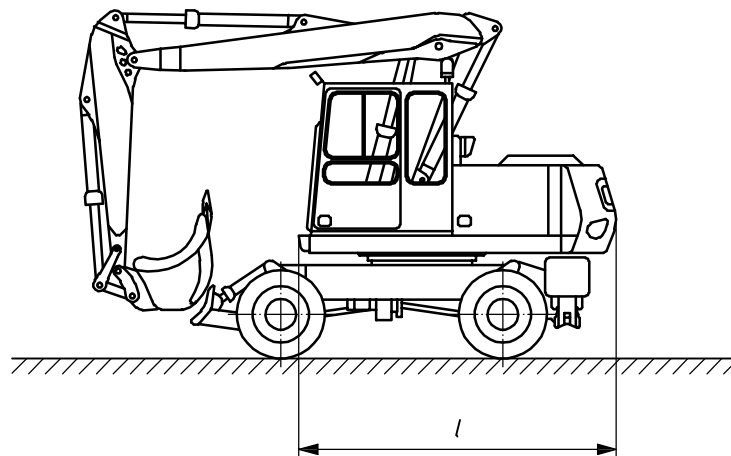

Figure A.9

### A.4.2 Crawler excavator

See Figure A.10.

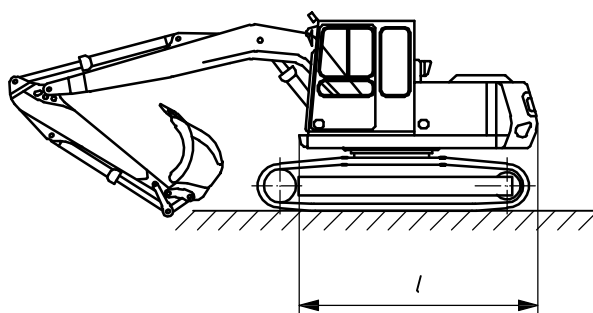
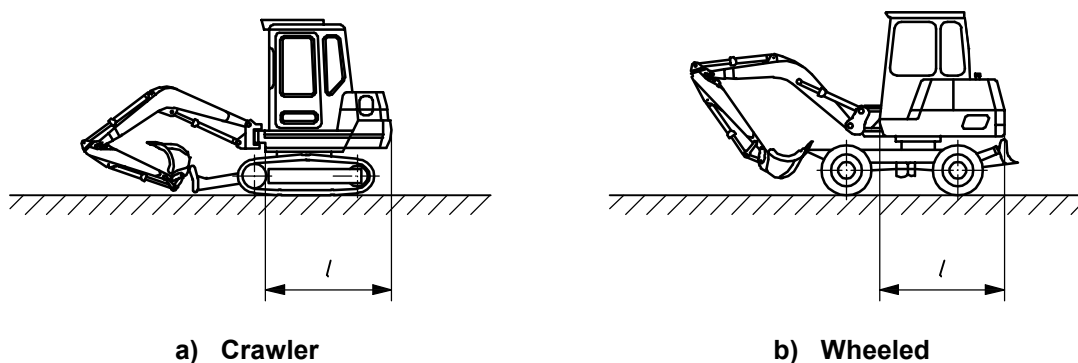

Figure A.10

### A.4.3 Compact excavator

Excavator with an operating mass  $\leq 6\,000$  kg. See Figure A.11.



a) Crawler

b) Wheeled

Figure A.11

#### A.4.4 Walking excavator

See Figure A.12.

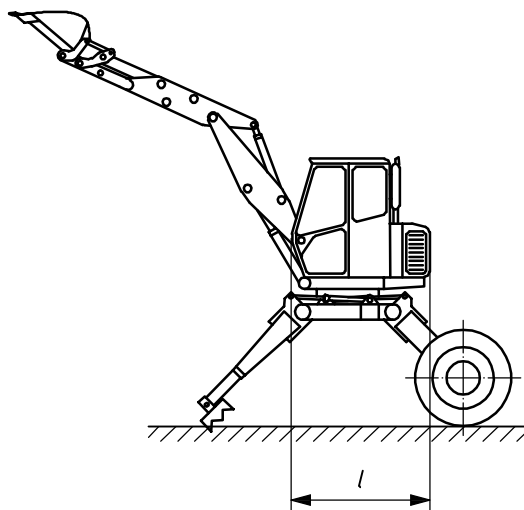

Figure A.12

#### A.5 Dumper

##### A.5.1 Wheeled rigid-frame dumper

See Figure A.13.

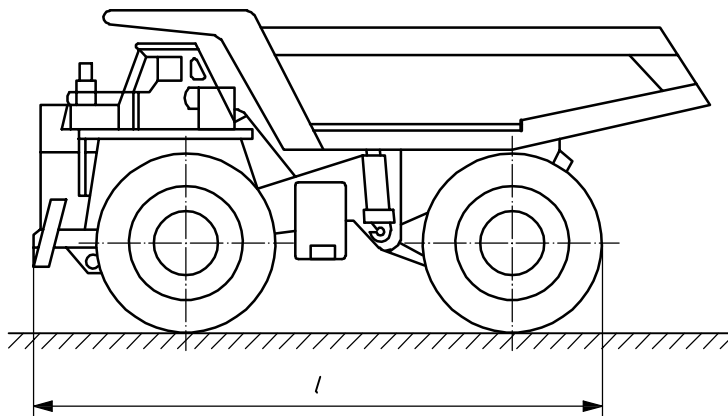

Figure A.13

### A.5.2 Articulated-frame dumper

See Figure A.14.

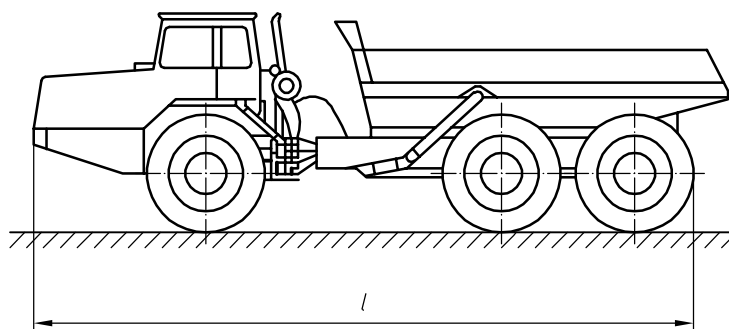

Figure A.14

### A.5.3 Crawler dumper

See Figure A.15.

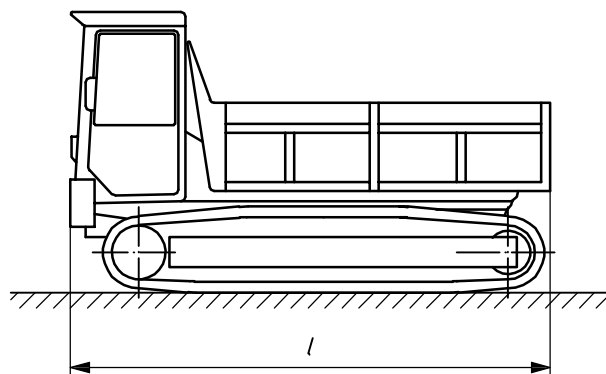

Figure A.15

### A.5.4 Compact dumper, wheeled

Wheeled dumper with an operating mass  $\leq 4\,500$  kg. See Figure A.16.

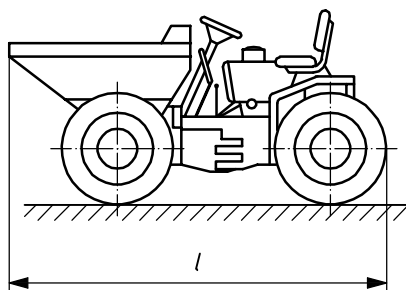
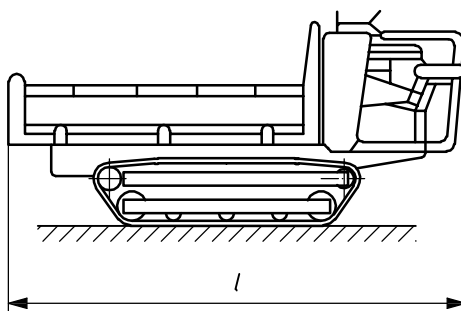

Figure A.16

**A.5.5 Compact dumper, crawler**

Crawler dumper with an operating mass  $\leq 4\,500$  kg. See Figure A.17.

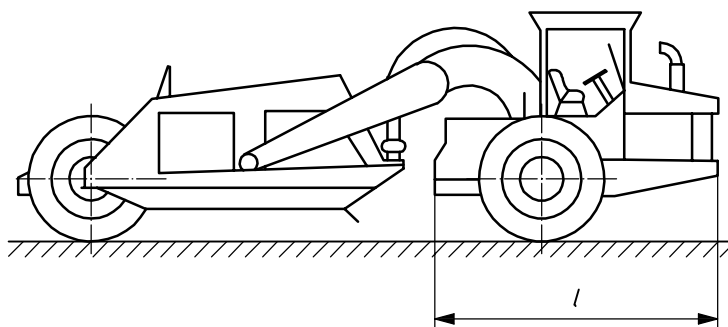

**Figure A.17**

**A.6 Scraper**

**A.6.1 Scraper with one engine**

See Figure A.18.

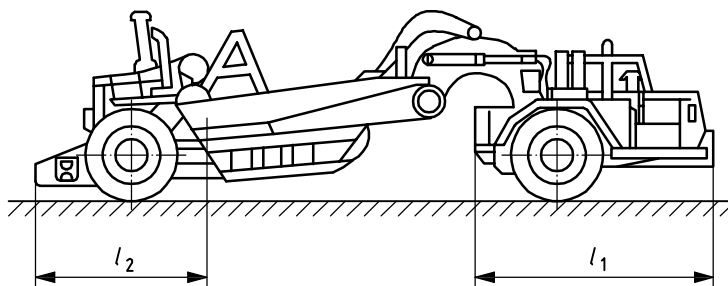

**Figure A.18**

**A.6.2 Scraper with two engines**

**A.6.2.1 Positioning of the machine and measurement**

Each engine of the scraper (lengths  $l_1$  and  $l_2$  in Figure A.19) shall be treated as a separate part for the positioning of the machine as specified in 6.3.1. The centre point of each distance shall be used to position each engine of the scraper. The measurement shall be made in two subsequent steps with the engine which is not being measured stopped.



**Figure A.19**

**A.6.2.2 Calculation to combine the time-averaged A-weighted sound pressure levels of the two engines**

To calculate the combined time-averaged A-weighted sound pressure level,  $L_{pA,T}$ , in decibels of the independent measurements of the two engines, use Equation (A.1).

$$L_{pA,T} = 10 \lg \left( 10^{0,1L_{pA,1}} + 10^{0,1L_{pA,2}} \right) \text{ dB} \tag{A.1}$$

where

$L_{pA,1}$  is the result of measurement of the first engine;

$L_{pA,2}$  is the result of measurement of the second engine.

**A.6.3 Crawler scraper**

See Figure A.20.

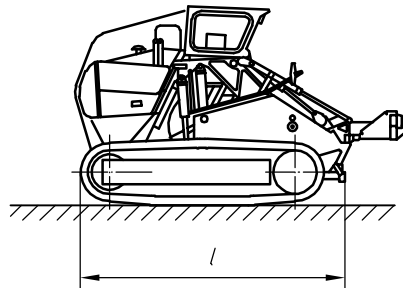

Figure A.20

**A.7 Grader**

See Figure A.21.

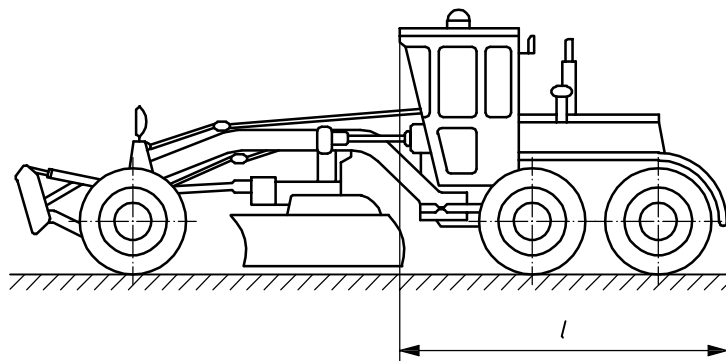

Figure A.21



## A.8 Pipelayer

See Figure A.22.

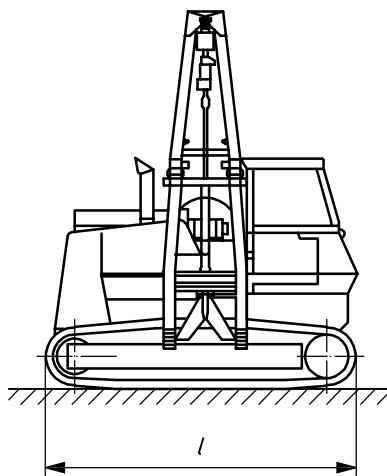

Figure A.22

## A.9 Trencher

### A.9.1 Wheeled ride-on trencher

See Figure A.23.

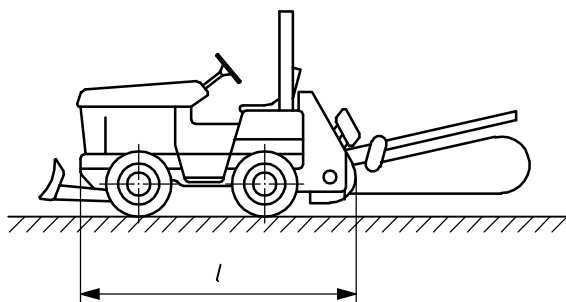

Figure A.23

### A.9.2 Crawler ride-on trencher

See Figure A.24.

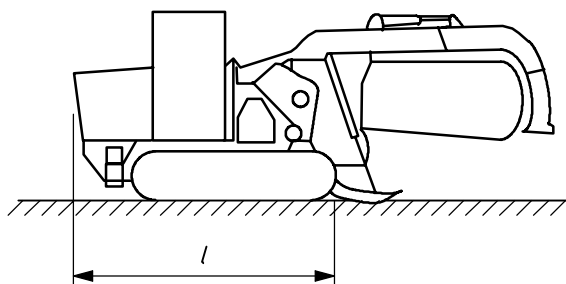

Figure A.24

### A.9.3 Walk-behind trencher

See Figure A.25.

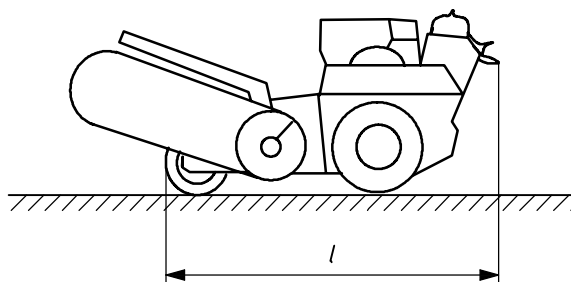

Figure A.25

### A.9.4 Disk trencher

See Figure A.26.

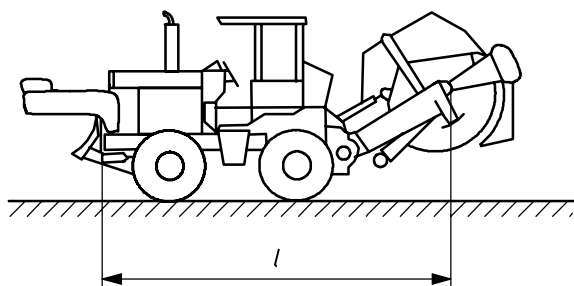

Figure A.26

## A.10 Landfill compactors

### A.10.1 Landfill compactor with loading equipment

See Figure A.27.

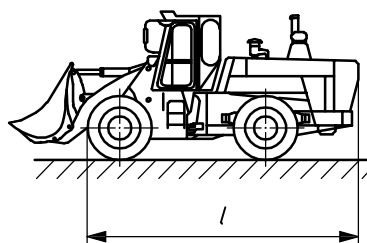
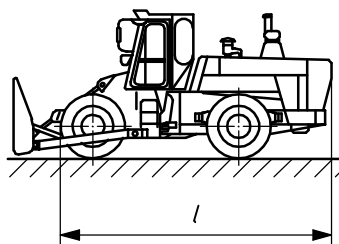

Figure A.27

**A.10.2 Landfill compactor with dozing equipment**

See Figure A.28.



**Figure A.28**

**A.11 Rollers**

See Figure A.29.

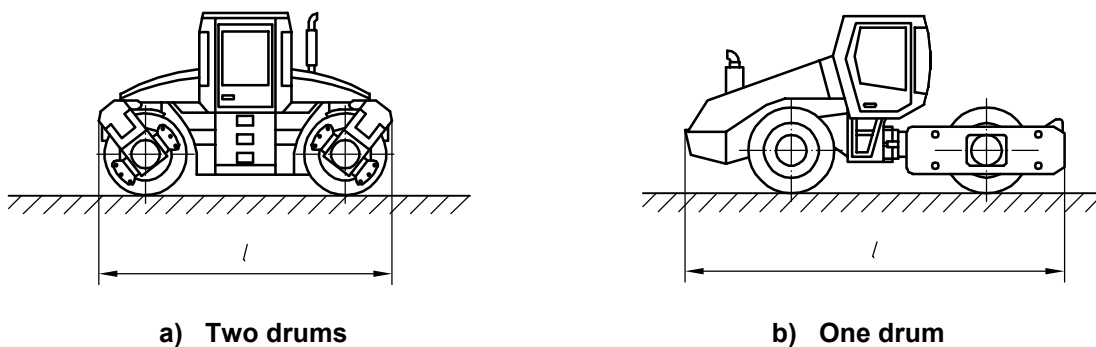

**a) Two drums**

**b) One drum**

**Figure A.29**

## Annex B (normative)

### Declaration of sound emission data and uncertainty

If a declaration of sound emission data and uncertainty is to be made, for example, for compliance with regulatory requirements, the following shall be observed.

The measurement uncertainty and, in the case of series machines, the uncertainty due to production variations shall be considered when determining the value of the A-weighted sound power level.

The maximum value of the standard deviation of reproducibility of the measured A-weighted sound power level is 1,5 dB, in accordance with ISO 3744:—, Table 2. The standard deviation of reproducibility is as defined in ISO 4871:1996, 3.21 (repeated application of the same noise emission determination method at the same noise source at different times and under different conditions).

Guidelines on declaration of sound emission values are given in ISO 4871:1996, Annex A.

The A-weighted sound power level and the associated uncertainty shall be declared separately (dual-number noise emission data declaration), as shown, for example, in ISO 4871:1996, B.2, or other methods for declaration can be used.

NOTE 1 Current experience tends to show that the value of the standard deviation of reproducibility for A-weighted sound power levels is between 0,5 dB and 0,8 dB.

NOTE 2 Experience has proved that the reference standard deviation,  $\sigma_M$ , as defined in ISO 4871:1996, 3.24 (specified for each family of earth-moving machinery and considered typical for batches of machinery from the family) is far below the estimated value of  $\sigma_M$  given in ISO 4871:1996, Table A.1. According to current reliable data, the reference standard deviation,  $\sigma_M$ , for A-weighted sound power levels and for earth-moving machinery is likely to be approximately 1,0 dB.

NOTE 3 The information given in Note 1 and Note 2 is based on experience in accordance with European regulations (e.g. Directive 2000/14/EC).

## Bibliography

- [1] ISO 4871:1996, *Acoustics — Declaration and verification of noise emission values of machinery and equipment*
- [2] ISO 6394, *Earth-moving machinery — Determination of emission sound pressure level at operator's position — Stationary test conditions*
- [3] ISO 6395, *Earth-moving machinery — Determination of sound power level — Dynamic test conditions*
- [4] ISO 6396, *Earth-moving machinery — Determination of emission sound pressure level at operator's position — Dynamic test conditions*
- [5] Directive 2000/14/EC of the European Parliament and of the Council of 8 May 2000 *on the approximation of the laws of the Member States relating to the noise emission in the environment by equipment for use outdoors*

www.iso.org

---

---

**ICS 17.140.20; 53.100**

Price based on 23 pages