

---

---

**Wrought aluminium and aluminium  
alloys — Extruded rods/bars, tubes and  
profiles —**

**Part 6:  
Round, square, rectangular and  
hexagonal tubes — Tolerances on shape  
and dimensions**

*Aluminium et alliages d'aluminium corroyés — Barres, tubes et  
profilés filés —*

*Partie 6: Tubes ronds, carrés, rectangulaires et hexagonaux —  
Tolérances sur forme et dimensions*





**COPYRIGHT PROTECTED DOCUMENT**

© ISO 2012

All rights reserved. Unless otherwise specified, no part of this publication may be reproduced or utilized in any form or by any means, electronic or mechanical, including photocopying and microfilm, without permission in writing from either ISO at the address below or ISO's member body in the country of the requester.

ISO copyright office  
Case postale 56 • CH-1211 Geneva 20  
Tel. + 41 22 749 01 11  
Fax + 41 22 749 09 47  
E-mail [copyright@iso.org](mailto:copyright@iso.org)  
Web [www.iso.org](http://www.iso.org)

Published in Switzerland

# Contents

Page

Foreword .....	iv
<b>1 Scope .....</b>	<b>1</b>
<b>2 Normative references .....</b>	<b>1</b>
<b>3 Terms and definitions .....</b>	<b>1</b>
<b>4 Materials .....</b>	<b>1</b>
<b>5 Tolerances on dimensions .....</b>	<b>2</b>
<b>5.1 General .....</b>	<b>2</b>
<b>5.2 Tolerances on diameter for round tube .....</b>	<b>3</b>
<b>5.3 Tolerances on width, depth or width across flats — Squares, rectangles, hexagons .....</b>	<b>4</b>
<b>5.4 Tolerances on wall thickness for round tube .....</b>	<b>6</b>
<b>5.5 Tolerances on wall thickness for tubes that are other than round .....</b>	<b>7</b>
<b>5.6 Tolerances on wall thickness variation (eccentricity) — Round tube .....</b>	<b>8</b>
<b>5.7 Tolerances on length of straight tube .....</b>	<b>9</b>
<b>5.8 Squareness of cut ends .....</b>	<b>10</b>
<b>6 Tolerances on form .....</b>	<b>10</b>
<b>6.1 General .....</b>	<b>10</b>
<b>6.2 Straightness .....</b>	<b>10</b>
<b>6.3 Convexity/concavity — Square and rectangular tube .....</b>	<b>11</b>
<b>6.4 Twist — Square and rectangular tube .....</b>	<b>12</b>
<b>6.5 Angularity — Square and rectangular tube .....</b>	<b>13</b>
<b>6.6 Corner and fillet radii — Square and rectangular tube .....</b>	<b>14</b>
<b>6.7 Depth of dents for round tube .....</b>	<b>14</b>
<b>Annex A (informative) Wall thickness variation (eccentricity) .....</b>	<b>15</b>

## Foreword

ISO (the International Organization for Standardization) is a worldwide federation of national standards bodies (ISO member bodies). The work of preparing International Standards is normally carried out through ISO technical committees. Each member body interested in a subject for which a technical committee has been established has the right to be represented on that committee. International organizations, governmental and non-governmental, in liaison with ISO, also take part in the work. ISO collaborates closely with the International Electrotechnical Commission (IEC) on all matters of electrotechnical standardization.

International Standards are drafted in accordance with the rules given in the ISO/IEC Directives, Part 2.

The main task of technical committees is to prepare International Standards. Draft International Standards adopted by the technical committees are circulated to the member bodies for voting. Publication as an International Standard requires approval by at least 75 % of the member bodies casting a vote.

Attention is drawn to the possibility that some of the elements of this document may be the subject of patent rights. ISO shall not be held responsible for identifying any or all such patent rights.

ISO 6362-6 was prepared by Technical Committee ISO/TC 79, *Light metals and their alloys*, Subcommittee SC 6, *Wrought aluminium and aluminium alloys*.

ISO 6362 consists of the following parts, under the general title *Wrought aluminium and aluminium alloys — Extruded rods/bars, tubes and profiles*:

- *Part 1: Technical conditions for inspection and delivery*
- *Part 2: Mechanical properties*
- *Part 3: Extruded rectangular bars — Tolerances on shape and dimensions*
- *Part 4: Profiles — Tolerances on shape and dimensions*
- *Part 5: Round, square and hexagonal bars — Tolerances on shape and dimensions*
- *Part 6: Round, square, rectangular and hexagonal tubes — Tolerances on shape and dimensions*
- *Part 7: Chemical composition*

# Wrought aluminium and aluminium alloys — Extruded rods/ bars, tubes and profiles —

## Part 6: Round, square, rectangular and hexagonal tubes — Tolerances on shape and dimensions

### 1 Scope

This part of ISO 6362 specifies the tolerances on dimensions and shape of wrought aluminium and aluminium alloy extruded round bars having diameters in the range from 8 mm up to 350 mm; and square and hexagonal bars having widths across flats in the range from 10 mm up to 220 mm.

It applies to extruded round, square and hexagonal bars.

### 2 Normative references

The following referenced documents are indispensable for the application of this document. For dated references, only the edition cited applies. For undated references, the latest edition of the referenced document (including any amendments) applies.

ISO 6362-1, *Wrought aluminium and aluminium alloys — Extruded rods/bars, tubes and profiles — Part 1: Technical conditions for inspection and delivery*

### 3 Terms and definitions

For the purposes of this document, the terms and definitions given in ISO 6362-1 apply.

### 4 Materials

For the purposes of this part of ISO 6362, wrought aluminium and aluminium alloys are divided into two groups, which correspond to varying difficulty when manufacturing the products.

The division into group I and group II of the most commonly used general engineering alloys is specified in Table 1 (for seamless tube) and Table 2 (for porthole tube). Grouping of other alloys is subject to agreement between the purchaser and supplier.

**Table 1 — Alloy group A (for seamless tube)**

<b>Group I</b>	1070, 1050, 1050A, 1350, 1100, 1200 3102, 3003, 3103, 3203 5005, 5005A, 5051A 6101, 6101A, 6101B, 6005, 6005A, 6005C, 6008, 6014, 6060, 6360, 6063, 6063A, 6463
<b>Group II</b>	2007, 2011, 2011A, 2014, 2014A, 2017,2017A, 2024, 2030 5019, 5049, 5051, 5251, 5052, 5154, 5154A, 5454, 5754, 5056, 5083, 5086 6110A, 6012, 6018, 6351, 6061, 6261, 6262, 6081, 6082 7003, 7204, 7005, 7108, 7108A, 7020, 7021, 7022, 7049A, 7050, 7075
NOTE The four-digit numbers listed are taken from the Registration of International Alloy Designations and Chemical Composition Limits for Wrought Aluminium Alloys, published by the Aluminum Association, 1525 Wilson Boulevard, Suite 600, Arlington, VA 22209, USA (known as "Teal Sheets").	

**Table 2 — Alloy group B (for porthole tube)**

<b>Group I</b>	1070, 1050, 1050A, 1350, 1100, 1200 3102, 3003, 3103, 3203 5005, 5005A 6101, 6101A, 6101B, 6005, 6005A, 6005C, 6008, 6014, 6060, 6360, 6063, 6063A, 6463
<b>Group II</b>	5051, 5049, 5251, 5052 6110A, 6012, 6018, 6351, 6061, 6261, 6262, 6081, 6082 7003, 7005, 7108, 7108A, 7020
NOTE The four-digit numbers listed are taken from the Registration of International Alloy Designations and Chemical Composition Limits for Wrought Aluminium Alloys, published by the Aluminum Association, 1525 Wilson Boulevard, Suite 600, Arlington, VA 22209, USA (known as "Teal Sheets").	

## 5 Tolerances on dimensions

### 5.1 General

When outside diameter OD, inside diameter ID, and wall thickness  $t$ , are all specified, standard tolerances shall apply to any two of these dimensions, but not to all three. As a result, the purchaser shall only state two nominal dimensions on any given order.

For round tubes see Figure 1. For any tubes that are other than round, see Figure 2.

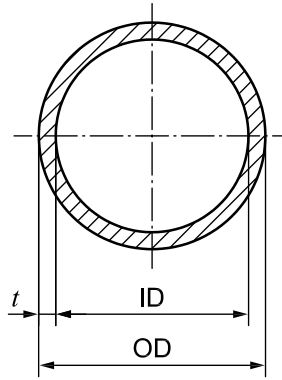

**Key**

ID inside diameter  
OD outside diameter

**Figure 1 — Round tube**

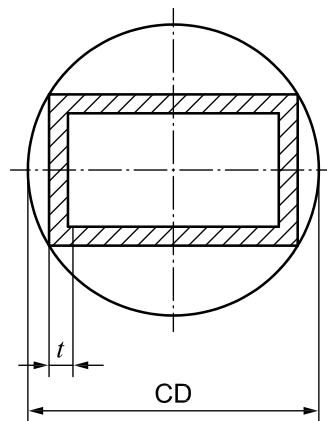

**Key**

CD circumscribed diameter

**Figure 2 — Circumscribing circle for tubes that are other than round**

**5.2 Tolerances on diameter for round tube**

Tolerances on diameter for round tube shall be in accordance with Table 3.

Table 3 — Tolerances on diameter for round tube

Dimensions in millimetres

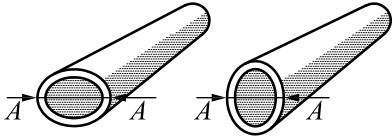
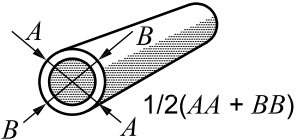
Diameter OD or ID	Tolerance on diameter for round tube			
	Maximum allowable deviation of diameter at any point from specified diameter <sup>a</sup>		Maximum allowable deviation of mean diameter from specified diameter <sup>b</sup>	
				
	Alloy group I <sup>c</sup>	Alloy group II <sup>c</sup>	Alloy group I <sup>c</sup>	Alloy group II <sup>c</sup>
13 ≤ OD or ID ≤ 25	± 0,51	± 0,76	± 0,25	± 0,38
25 < OD or ID ≤ 50	± 0,64	± 0,97	± 0,30	± 0,40
50 < OD or ID ≤ 100	± 0,76	± 1,14	± 0,38	± 0,58
100 < OD or ID ≤ 150	± 1,27	± 1,91	± 0,64	± 0,97
150 < OD or ID ≤ 200	± 1,91	± 2,87	± 0,89	± 1,35
200 < OD or ID ≤ 250	± 2,54	± 3,81	± 1,14	± 1,73
250 < OD or ID ≤ 300	± 3,18	± 4,78	± 1,40	± 2,11
300 < OD or ID ≤ 350	± 3,81	± 5,72	± 1,65	± 2,49
350 < OD or ID ≤ 400	± 4,45	± 6,68	± 1,91	± 2,87
400 < OD or ID ≤ 450	± 5,08	± 7,62	± 2,16	± 3,25

When the tolerance is specified only for either the plus or the minus side, the values in this table shall be doubled.  
Tolerances on dimensions exceeding the specified range shall be agreed upon between the purchaser and the supplier.

<sup>a</sup> These values are not applied to the tubes of temper grade O, coiled tubes and tubes with wall thickness less than 2,5 % of the specified outside diameter.  
<sup>b</sup> The mean diameter is defined as the average value of measurements made at two arbitrary points at right angles to each other.  
<sup>c</sup> Refer to Table 1.

5.3 Tolerances on width, depth or width across flats — Squares, rectangles, hexagons

5.3.1 Seamless tube

The tolerances on width, depth or width across flats for seamless tubes that are other than round are specified in Table 4.



Table 4 — Tolerances on width, depth or width across flats for seamless tubes that are other than round

Dimensions in millimetres

Width, depth or width across flats $W$	Tolerances on width, depth or width across flats for seamless tubes that are other than round <sup>a,b</sup>							
	$CD \leq 100$		$100 < CD \leq 200$		$200 < CD \leq 300$		$300 < CD \leq 350$	
	Alloy group <sup>c</sup>							
	I	II	I	II	I	II	I	II
$W \leq 10$	$\pm 0,25$	$\pm 0,40$	$\pm 0,30$	$\pm 0,50$	$\pm 0,35$	$\pm 0,55$	$\pm 0,40$	$\pm 0,60$
$10 < W \leq 25$	$\pm 0,30$	$\pm 0,50$	$\pm 0,40$	$\pm 0,70$	$\pm 0,50$	$\pm 0,80$	$\pm 0,60$	$\pm 0,90$
$25 < W \leq 50$	$\pm 0,50$	$\pm 0,80$	$\pm 0,60$	$\pm 0,90$	$\pm 0,80$	$\pm 1,00$	$\pm 0,90$	$\pm 1,20$
$50 < W \leq 100$	$\pm 0,70$	$\pm 1,00$	$\pm 0,90$	$\pm 1,20$	$\pm 1,10$	$\pm 1,30$	$\pm 1,30$	$\pm 1,60$
$50 < W \leq 150$	-	-	$\pm 1,10$	$\pm 1,50$	$\pm 1,30$	$\pm 1,70$	$\pm 1,50$	$\pm 1,80$
$150 < W \leq 200$	-	-	$\pm 1,30$	$\pm 1,90$	$\pm 1,50$	$\pm 2,20$	$\pm 1,80$	$\pm 2,40$
$200 < W \leq 300$	-	-	-	-	$\pm 1,70$	$\pm 2,50$	$\pm 2,10$	$\pm 2,80$
$300 < W \leq 350$	-	-	-	-	-	-	$\pm 2,80$	$\pm 3,50$

<sup>a</sup> Not applicable to tubes having a wall thickness less than 2,5 % of the specified outside width, depth or width across flats. The tolerance for tubes with wall thickness less than 2,5 % of the specified width, depth or width across flats shall be determined by multiplying the applicable tolerance as follows:

- wall thickness over 2,0 % up to and including 2,5 % of outside parameter: 1,5 × tolerance;
- wall thickness over 1,5 % up to and including 2,0 % of outside parameter: 2,0 × tolerance;
- wall thickness over 1,0 % up to and including 1,5 % of outside parameter: 3,0 × tolerance;
- wall thickness over 0,5 % up to and including 1,0 % of outside parameter: 4,0 × tolerance.

<sup>b</sup> These tolerances do not apply to tempers O and Tx510. For these tempers, the tolerances shall be subject to agreement between the supplier and purchaser.

<sup>c</sup> Refer to Table 1.

### 5.3.2 Porthole tube

The tolerances on width, depth or width across flats for porthole tubes that are other than round are specified in Table 5.

**Table 5 — Tolerances on width, depth or width across flats for porthole tubes that are other than round**

Dimensions in millimetres

Width, depth or width across flats <i>W</i>	Tolerances on width, depth or width across flats for porthole tubes that are other than round <sup>a,b</sup>							
	CD ≤ 100		100 < CD ≤ 200		200 < CD ≤ 300		300 < CD ≤ 350	
	Alloy group <sup>c</sup>							
	I	II	I	II	I	II	I	II
$W \leq 10$	± 0,25	± 0,40	± 0,30	± 0,50	± 0,35	± 0,55	± 0,40	± 0,60
$10 < W \leq 25$	± 0,30	± 0,50	± 0,40	± 0,70	± 0,50	± 0,80	± 0,60	± 0,90
$25 < W \leq 50$	± 0,50	± 0,80	± 0,60	± 0,90	± 0,80	± 1,00	± 0,90	± 1,20
$50 < W \leq 100$	± 0,70	± 1,00	± 0,90	± 1,20	± 1,10	± 1,30	± 1,30	± 1,60
$50 < W \leq 150$	-	-	± 1,10	± 1,50	± 1,30	± 1,70	± 1,50	± 1,80
$150 < W \leq 200$	-	-	± 1,30	± 1,90	± 1,50	± 2,20	± 1,80	± 2,40
$200 < W \leq 300$	-	-	-	-	± 1,70	± 2,50	± 2,10	± 2,80
$300 < W \leq 350$	-	-	-	-	-	-	± 2,80	± 3,50

<sup>a</sup> Not applicable to tubes having a wall thickness less than 2,5 % of the specified outside width, depth or width across flats. The tolerance for tubes with wall thickness less than 2,5 % of the specified width, depth or width across flats shall be determined by multiplying the applicable tolerance as follows:  
— wall thickness over 2,0 % up to and including 2,5 % of outside parameter: 1,5 × tolerance;  
— wall thickness over 1,5 % up to and including 2,0 % of outside parameter: 2,0 × tolerance;  
— wall thickness over 1,0 % up to and including 1,5 % of outside parameter: 3,0 × tolerance;  
— wall thickness over 0,5 % up to and including 1,0 % of outside parameter: 4,0 × tolerance.

<sup>b</sup> These tolerances do not apply to tempers O and Tx510. For these tempers, the tolerances shall be subject to agreement between the supplier and purchaser.

<sup>c</sup> Refer to Table 2.

#### 5.4 Tolerances on wall thickness for round tube

The tolerances on wall thickness for round tubes are specified in Table 6.

Table 6 — Tolerances on wall thickness for round tubes

Dimensions in millimetres

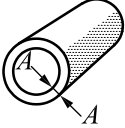
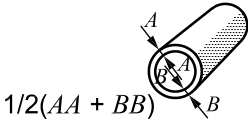
Wall thickness <sup>a</sup> <i>t</i>	Tolerance on wall thickness for round tubes								
	Maximum allowable deviation of wall thickness at any point from specified wall thickness	Maximum allowable deviation of mean wall thickness from specified wall thickness <sup>b</sup>							
									
		Outside diameter OD				Alloy group <sup>c</sup>			
	OD ≤ 30		30 < OD ≤ 75		75 < OD ≤ 125		125 < OD		
	I	II	I	II	I	II	I	II	
$t \leq 1$	± 0,15	-	-	-	-	-	-	-	
$1 < t \leq 1,5$	± 0,18	-	± 0,20	-	± 0,20	-	± 0,25	-	
$1,5 < t \leq 2$	± 0,20	-	± 0,20	-	± 0,23	-	± 0,30	-	
$2 < t \leq 3$	± 0,23	-	± 0,23	-	± 0,25	-	± 0,38	-	
$3 < t \leq 6$	±10 % of the mean wall thickness Max. ± 1,52 Min. ± 0,25	± 0,23	± 0,36	± 0,23	± 0,36	± 0,33	± 0,51	± 0,51	± 0,76
$6 < t \leq 10$		± 0,28	± 0,43	± 0,28	± 0,43	± 0,41	± 0,61	± 0,64	± 0,97
$10 < t \leq 12$		-	-	± 0,38	± 0,58	± 0,53	± 0,81	± 0,89	± 1,35
$12 < t \leq 20$		-	-	± 0,51	± 0,76	± 0,71	± 1,07	± 1,14	± 1,73
$20 < t \leq 25$		-	-	-	-	± 0,89	± 1,35	± 1,40	± 2,11
$25 < t \leq 38$	-	-	-	-	± 1,14	± 1,73	± 1,65	± 2,49	
$38 < t \leq 50$	-	-	-	-	-	-	± 1,91	± 2,87	
$50 < t \leq 60$	-	-	-	-	-	-	± 2,16	± 3,25	
$60 < t \leq 75$	±3,05	-	-	-	-	-	± 2,41	± 3,63	
$75 < t \leq 90$		-	-	-	-	-	± 2,67	± 4,01	
$90 < t \leq 100$		-	-	-	-	-	± 2,92	± 4,39	
		-	-	-	-	-	-	-	

When the tolerance is specified only for either the plus or the minus side, the values in Table 6 shall be doubled.

Tolerances on dimensions exceeding the specified range shall be agreed upon between the purchaser and supplier.

<sup>a</sup> In the case where the outside diameter and inside diameter of tube are specified, apply the tolerance value specified in the second column "Maximum allowable deviation of wall thickness at any point from specified wall thickness", taking the mean wall thickness as the wall thickness.

<sup>b</sup> The mean wall thickness is defined as the average value of measurements made at two arbitrary positions facing each other with the pipe axis between them.

<sup>c</sup> Refer to Table 1.

## 5.5 Tolerances on wall thickness for tubes that are other than round

### 5.5.1 Seamless tube

The tolerances on wall thickness for seamless tubes that are other than round are specified in Table 7.

Table 7 — Tolerances on wall thickness for seamless tubes that are other than round

Dimensions in millimetres

Nominal wall thickness $t$	Tolerances on wall thickness for seamless tubes that are other than round					
	CD ≤ 100		100 < CD ≤ 300		300 < CD ≤ 350	
	Alloy group <sup>a</sup>					
	I	II	I	II	I	II
0,5 ≤ $t$ ≤ 1,5	± 0,25	± 0,35	± 0,35	± 0,50	-	-
1,5 < $t$ ≤ 3	± 0,30	± 0,45	± 0,50	± 0,65	± 0,75	± 0,90
3 < $t$ ≤ 6	± 0,50	± 0,60	± 0,75	± 0,90	± 1,00	± 1,20
6 < $t$ ≤ 10	± 0,75	± 1,00	± 1,00	± 1,30	± 1,20	± 1,50
10 < $t$ ≤ 15	± 1,00	± 1,30	± 1,20	± 1,70	± 1,50	± 1,90
15 < $t$ ≤ 20	± 1,50	± 1,90	± 1,90	± 2,20	± 2,00	± 2,50
20 < $t$ ≤ 30	± 1,90	± 2,20	± 2,20	± 2,70	± 2,50	± 3,10
30 < $t$ ≤ 40	-	-	± 2,50	-	± 2,70	-

<sup>a</sup> Refer to Table 1.

### 5.5.2 Porthole tube

The tolerances on wall thickness for porthole tubes that are other than round are specified in Table 8.

Table 8 — Tolerances on wall thickness for porthole tubes that are other than round

Dimensions in millimetres

Nominal wall thickness $t$	Tolerances on wall thickness for porthole tubes that are other than round					
	CD ≤ 100		100 < CD ≤ 300		300 < CD ≤ 350	
	Alloy group <sup>a</sup>					
	I	II	I	II	I	II
0,5 ≤ $t$ ≤ 1,5	± 0,20	± 0,30	± 0,30	± 0,40	-	-
1,5 < $t$ ≤ 3	± 0,25	± 0,35	± 0,40	± 0,50	± 0,60	± 0,70
3 < $t$ ≤ 6	± 0,40	± 0,55	± 0,60	± 0,70	± 0,80	± 0,90
6 < $t$ ≤ 10	± 0,60	± 0,75	± 0,80	± 1,00	± 1,00	± 1,20
10 < $t$ ≤ 15	± 0,80	± 1,00	± 1,00	± 1,30	± 1,20	± 1,50
15 < $t$ ≤ 20	± 1,20	± 1,50	± 1,50	± 1,80	± 1,70	± 2,00
20 < $t$ ≤ 30	± 1,50	± 1,80	± 1,80	± 2,20	± 2,00	± 2,50
30 < $t$ ≤ 40	-	-	± 2,00	± 2,50	± 2,00	± 3,00

<sup>a</sup> Refer to Table 2.

## 5.6 Tolerances on wall thickness variation (eccentricity) — Round tube

### 5.6.1 Seamless tube

The tolerances on wall thickness variation (eccentricity) for round seamless tubes are specified in Table 9.

**Table 9 — Tolerances on wall thickness (eccentricity) for round seamless tubes**

Nominal wall thickness $t$ mm	Tolerance on wall thickness variation (eccentricity) for round seamless tubes <sup>a</sup>		
	%		
$t \leq 3$	± 10		
$3 < t \leq 5$	± 9		
$5 < t$	± 8		

NOTE Round tube dimensions can be expressed in three different ways, i.e. outside diameter (OD) × wall thickness ( $t$ ), inside diameter (ID) ×  $t$  (where  $t$  is the nominal wall thickness) and OD × ID. Depending on the way of ordering the tube the values in Table 7 should be understood as follows (see Annex A for further explanation):

- for tubes specified as OD ×  $t$  or ID ×  $t$ , the values are the allowable variation at any point;
- for tubes specified as OD × ID, the above values are the allowable variation from the calculated mean wall thickness.

<sup>a</sup> For OD greater than 150 mm together with an OD/ $t$  ratio of more than 10, the tolerance on wall thickness variation shall be subjected to agreement between the supplier and purchaser.

### 5.6.2 Porthole tube

The tolerances on wall thickness variation (eccentricity) for round porthole tubes are specified in Table 10.

**Table 10 — Tolerances on wall thickness (eccentricity) for round porthole tubes**

Nominal wall thickness $t$ mm	Tolerance on wall thickness variation (eccentricity) for round porthole tubes		
	%		
	OD < 150	150 ≤ OD < 300	300 ≤ OD
$t \leq 3$	± 7	± 9	± 11
$3 < t \leq 5$	± 6	± 8	± 10
$5 < t$	± 5	± 7	± 9

NOTE Round tube dimensions can be expressed in three different ways, i.e. outside diameter (OD) × wall thickness ( $t$ ), inside diameter (ID) ×  $t$  (where  $t$  is the nominal wall thickness) and OD × ID. Depending on the way of ordering, the tube the values in Table 8 should be understood as follows (see Annex A for further explanation):

- for tubes specified as OD ×  $t$  or ID ×  $t$ , the values are the allowable variation at any point;
- for tubes specified as OD × ID, the above values are the allowable variation from the calculated mean wall thickness.

### 5.7 Tolerances on length of straight tube

Tolerances on fixed length of straight tube shall be in accordance with Table 11.

**Table 11 — Tolerances on fixed length of straight tube**

Dimensions in millimetres

Outside diameter OD	Tolerance on fixed lengths $L$		
	$L \leq 3\,500$	$3\,500 < L \leq 9\,000$	$9\,000 < L \leq 15\,000$
$13 \leq OD \leq 75$	+4 0	+7 0	+10 0
$75 < OD \leq 200$	+5 0	+8 0	+11 0
$200 < OD \leq 450$	+7 0	+10 0	+13 0

Tolerances on dimensions exceeding the range of specified dimensions shall be agreed upon between the purchaser and the supplier.

## 5.8 Squareness of cut ends

The squareness of cut ends shall be within half of the fixed-length tolerance range specified in Table 11 for both fixed and random lengths.

For example for a fixed-length tolerance of  $^{+10}_0$  mm, the squareness of cut ends shall be within 5 mm.

## 6 Tolerances on form

### 6.1 General

Tolerances on form for O temper shall be subject to agreement between the purchaser and supplier.

### 6.2 Straightness

#### 6.2.1 Round tube

The straightness tolerance of round tubes is specified in Table 12.

**Table 12 — Tolerances on straightness of round tube**

Dimensions in millimetres

Outside diameter OD	Tolerances on straightness of round tube <sup>a,b</sup>	
	Maximum allowable deviation of straightness for any 300 mm length	Maximum allowable deviation of straightness for total length <sup>c</sup> $L$
$13 \leq OD \leq 150$	0,3	$0,3 \times \frac{L}{300}$
$150 < OD \leq 300$	0,5	$0,5 \times \frac{L}{300}$
$300 < OD \leq 450$	0,9	$0,9 \times \frac{L}{300}$

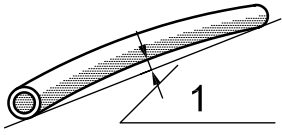

**Key**  
1 straightness

Tolerance on dimensions exceeding the range of specified dimensions shall be agreed upon between the purchaser and supplier.

<sup>a</sup> These values are obtained by placing the tube on a flat surface so that the mass of the tube minimizes the deviation.  
<sup>b</sup> These values do not apply to temper grade O.  
<sup>c</sup> When the total length of tube does not constitute an integral multiple of 300 mm, the tolerance is determined by rounding up fractions to a unit for every 300 mm.

#### 6.2.2 Tubes that are other than round

Deviations from straightness,  $h_s$  and  $h_t$ , shall be measured as shown in Figure 3 with the tube placed on a horizontal base-plate so that its mass decreases the deviation.

The straightness tolerance  $h_t$  of tubes that are other than round shall not exceed 1,5 mm/m length. Local deviations  $h_s$  from straightness shall not exceed 0,6 mm/300 mm length.

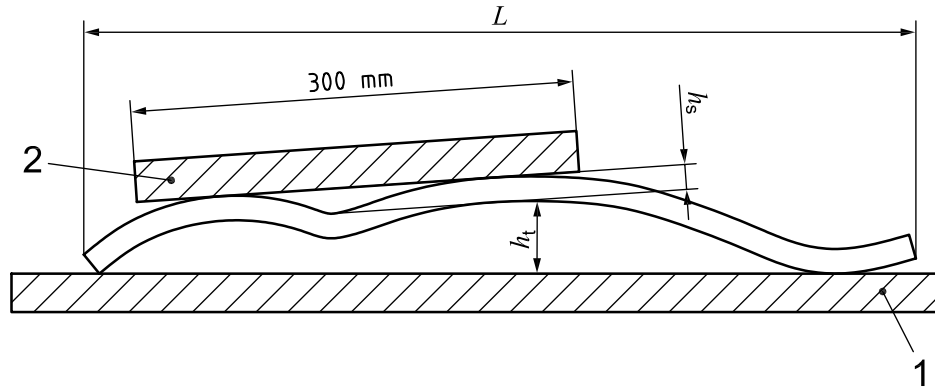

**Key**

- 1 base-plate
- 2 straight edge

**Figure 3 — Measurement of the deviation from straightness**

**6.3 Convexity/concavity — Square and rectangular tube**

The convexity/concavity of tubes that are other than round shall be measured as shown in Figure 4. The convexity/concavity tolerances are specified in Table 13.

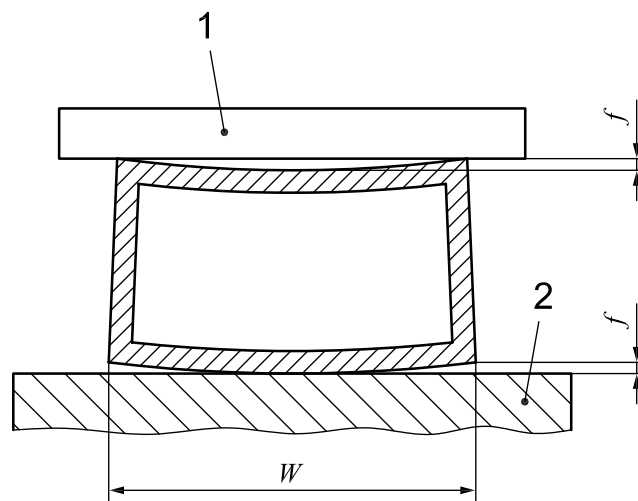

**Key**

- 1 straight edge
- 2 base-plate

**Figure 4 — Measurement of convexity/concavity**

Table 13 — Convexity/concavity tolerances

Dimensions in millimetres

Width $W$	Maximum allowable deviation	
	Wall thickness $\leq 5$	Wall thickness $> 5$
$W \leq 30$	0,30	0,20
$30 < W \leq 60$	0,40	0,30
$60 < W \leq 100$	0,60	0,40
$100 < W \leq 150$	0,90	0,60
$150 < W \leq 200$	1,20	0,80
$200 < W \leq 350$	1,80	1,20

6.4 Twist — Square and rectangular tube

Twist  $T$  shall be measured as shown in Figure 5 by placing the tube on a flat base-plate, the tube resting under its own mass and measuring the maximum distance at any point along the length between the bottom surface of the tube and the base-plate surface.

Twist tolerances are specified in Table 14 as a function of the width  $W$  and the length  $L$  of the tube.

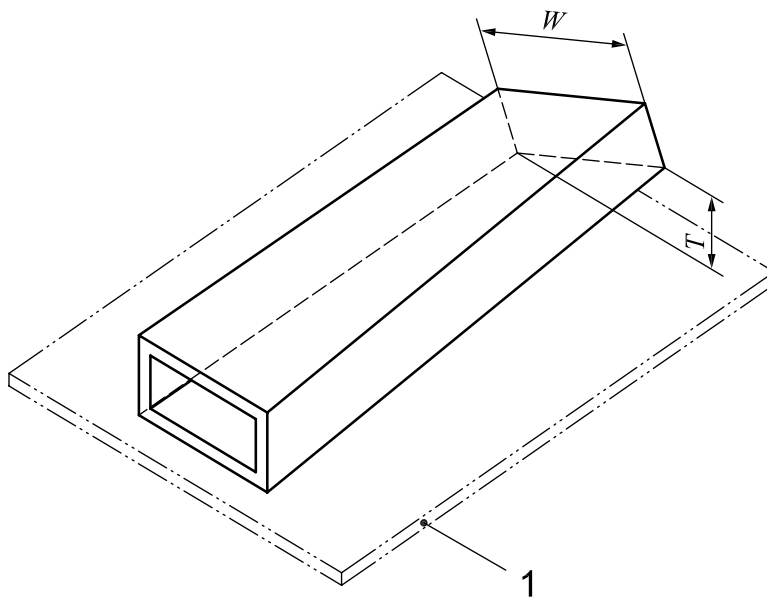

Key  
1 base-plate

Figure 5 — Measurement of twist



Table 14 — Twist tolerances

Dimensions in millimetres

Width $W$	Twist tolerances $T$		
	per 1 000 mm of length <sup>a</sup>	On total tube length $L$	
		$L \leq 6\,000$	$6\,000 < L$
$10 \leq W \leq 30$	1,2	2,5	3,0
$30 < W \leq 50$	1,5	3,0	4,0
$50 < W \leq 100$	2,0	3,5	5,0
$100 < W \leq 200$	2,5	5,0	7,0
$200 < W \leq 350$	2,5	6,0	8,0

<sup>a</sup> Twist tolerances for lengths less than 1 000 mm shall be subject to agreement between the supplier and purchaser.

### 6.5 Angularity — Square and rectangular tube

The deviation from square of square and rectangular tubes shall be measured as shown in Figure 6. The maximum allowable deviation from square is specified in Table 15 as a function of tube depth  $B$ . In the case of rectangular tubes, the tolerances on squareness shall apply to the shorter side of the tube.

The maximum allowable deviation in an angle other than a right angle (hexagonal tubes) shall be included within the tolerances on width across flats: see Table 4.

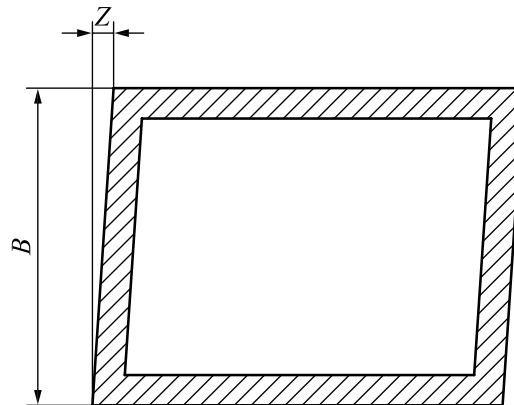

Figure 6 — Measurement of deviation from square

Table 15 — Squareness tolerances for square and rectangular tubes

Dimensions in millimetres

Depth $B$	Maximum allowable deviation from square $Z$
$B \leq 30$	0,4
$30 < B \leq 50$	0,7
$50 < B \leq 80$	1,0
$80 < B \leq 120$	1,4
$120 < B \leq 180$	2,0
$180 < B \leq 240$	2,6
$240 < B \leq 350$	3,1

## 6.6 Corner and fillet radii — Square and rectangular tube

Sharp corners and fillet radii may be slightly rounded unless otherwise indicated on the drawing. The maximum allowable radii are specified in Table 16 (seamless tube) and Table 17 (porthole tube).

When a corner or fillet radius is specified, the maximum allowable deviation from the nominal value is specified in Table 18.

**Table 16 — Maximum allowable corner and fillet radii for seamless tubes**

Dimensions in millimetres

Wall thickness	Maximum allowable corner and fillet radii	
	Alloy group I <sup>a</sup>	Alloy group II <sup>a,b</sup>
≤ 5	0,6	0,8
> 5	1,0	1,5
<sup>a</sup> Refer to Table 1. <sup>b</sup> These tolerances only apply to 6xxx series alloys in group II. The maximum allowable radii for the other alloys in group II shall be subject to agreement between the supplier and purchaser.		

**Table 17 — Maximum allowable corner and fillet radii for porthole tubes**

Wall thickness mm	Maximum allowable corner and fillet radii mm
≤ 5	0,8
> 5	1,5

**Table 18 — Maximum allowable deviation from specified corner and fillet radii**

Specified radius mm	Maximum allowable deviation from nominal value of the radius
≤ 5	± 0,5 mm
> 5	10 %

## 6.7 Depth of dents for round tube

In certain applications, the depth of surface dents can be an important factor, particularly for round tube with large diameter to wall thickness ratios. In such cases, the maximum allowable depth of dents shall be subject to agreement between the supplier and purchaser.

## Annex A (informative)

### Wall thickness variation (eccentricity)

#### A.1 General

Wall thickness variation tolerances for round tube can be the source of a lot of confusion. In particular as to whether quoted values are based on the nominal or mean wall thickness. This annex is included to provide some guidelines as to when each of these possibilities is more appropriate.

#### A.2 Specifying round tube sizes and tolerances

##### A.2.1 General

Round tube dimensions can be expressed in three different ways:

- outside diameter (OD)  $\times$  wall thickness ( $t$ );
- inside diameter (ID)  $\times t$  (where  $t$  is the nominal wall thickness);
- OD  $\times$  ID.

Since all three dimensions interact in any given size of tube, it is only possible to apply tolerances to any two of the parameters depending on which are the most important for the application of the tube in question. The choice of the dimensional parameters has a very significant effect on how the wall thickness variation is expressed.

The method of measuring wall thickness  $t$  is the same whether the given tube is specified as OD  $\times t$ , ID  $\times t$  or OD  $\times$  ID and is shown in Figure A.1.

The tube wall thickness is measured around the circumference of the tube and the maximum ( $t_{max}$ ) and minimum ( $t_{min}$ ) values established.

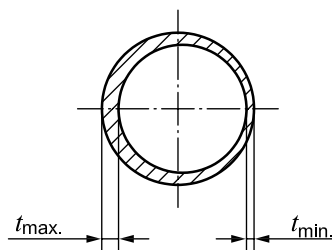

**Figure A.1 — Minimum and maximum values of the tube wall thickness**

##### A.2.2 Wall thickness variation for tubes specified as OD $\times t$ or ID $\times t$

For tube that is specified as either OD  $\times t$  or ID  $\times t$ , the nominal wall thickness  $t$  can be used as the basis for calculating and expressing the wall thickness variation tolerance. The tolerance can be expressed as the

difference (in millimetres) between the maximum and minimum values permissible for the tube, i.e. at any point, maximum wall thickness variation, deviation or concentricity:

$$t_{\max} - t_{\min} \text{ in mm} \quad (\text{A.1})$$

Alternatively, the difference can be expressed as a percentage of the nominal wall thickness which is normally divided by two to give a plus and minus tolerance. The percentage is normally expressed on a plus/minus basis as follows:

$$\frac{t_{\max} - t_{\min}}{2 t} \times 100 \% \quad (\text{A.2})$$

### A.2.3 Wall thickness variation for tubes specified as OD × ID

In the case of tubes specified as OD ×  $t$ , there is no nominal wall thickness available to allow the same method of calculation of wall thickness variation as that described in A.2.2. As a result, it is necessary to use the measured  $t_{\max}$  and  $t_{\min}$  values to give a wall thickness difference which is then used to calculate a percentage of the mean wall thickness.

$$\frac{t_{\max} - t_{\min}}{(t_{\max} + t_{\min})/2} \times 100 \% \quad (\text{A.3})$$

This value may then be divided by two to give a plus/minus value for the tolerance.

© ISO 2012 – All rights reserved

© ISO 2015

---

---

**ICS 77.150.10**

Price based on 16 pages