**Textile and laminate floor coverings —
Assessment of static electrical
propensity — Walking test**

*Revêtements de sol textiles et laminés — Évaluation de la propension à
l'accumulation des charges électrostatiques — Essai du marcheur*





COPYRIGHT PROTECTED DOCUMENT

© ISO 2012

All rights reserved. Unless otherwise specified, no part of this publication may be reproduced or utilized in any form or by any means, electronic or mechanical, including photocopying and microfilm, without permission in writing from either ISO at the address below or ISO's member body in the country of the requester.

ISO copyright office
Case postale 56 • CH-1211 Geneva 20
Tel. + 41 22 749 01 11
Fax + 41 22 749 09 47
E-mail copyright@iso.org
Web www.iso.org

Published in Switzerland

Contents

Page

Foreword	iv
Introduction	v
1 Scope	1
2 Normative references	1
3 Terms and definitions	1
4 Principle	1
5 Apparatus	2
5.1 Grounded metal base plate	2
5.2 Rubber mat	2
5.3 Polyethylene foam (PE-foam)	2
5.4 Polyethylene foil (PE-foil)	2
5.5 Test sandals	2
5.6 Means of cleaning the sandals	2
5.7 Ionizing source	3
5.8 Body voltage measuring system	3
5.9 Measuring devices for temperature and relative humidity	3
6 Sampling and selection of specimens	3
6.1 Textile floor coverings	3
6.2 Laminate	3
7 Preconditioning of specimens, PE-foam, PE-foil and rubber mats	3
8 Atmosphere for conditioning and testing	4
9 Test procedures	4
9.1 Preparation	4
9.2 Method A: test procedure in laboratory conditions	4
9.3 Method B: test procedure <i>in situ</i>	6
10 Calculation and expression of results	6
11 Test report	6
Annex A (normative) Specification of the sandals	7
Annex B (normative) Standard sole material — Neolite (standard XS-664P)	11
Annex C (normative) Standard sole material — BAM-rubber	12
Annex D (normative) Method for measuring the electrical resistance of the footwear	13
Annex E (normative) Example of a hand-held electrode and its use	15
Annex F (informative) Method of checking calibration of the measuring system	17
Bibliography	18

Foreword

ISO (the International Organization for Standardization) is a worldwide federation of national standards bodies (ISO member bodies). The work of preparing International Standards is normally carried out through ISO technical committees. Each member body interested in a subject for which a technical committee has been established has the right to be represented on that committee. International organizations, governmental and non-governmental, in liaison with ISO, also take part in the work. ISO collaborates closely with the International Electrotechnical Commission (IEC) on all matters of electrotechnical standardization.

International Standards are drafted in accordance with the rules given in the ISO/IEC Directives, Part 2.

The main task of technical committees is to prepare International Standards. Draft International Standards adopted by the technical committees are circulated to the member bodies for voting. Publication as an International Standard requires approval by at least 75 % of the member bodies casting a vote.

Attention is drawn to the possibility that some of the elements of this document may be the subject of patent rights. ISO shall not be held responsible for identifying any or all such patent rights.

ISO 6356 was prepared by Technical Committee ISO/TC 219, *Floor coverings*.

This second edition cancels and replaces the first edition (ISO 6356:2000), which has been technically revised.

Introduction

This test is a measurement of the electric potential (voltage) due to the accumulation of static charge on a person walking on the surface of a textile and laminate floor covering under controlled conditions. It is important that this measurement is made under carefully controlled conditions to minimize test variability.

© ISO 2012. All rights reserved.

.....

Textile and laminate floor coverings — Assessment of static electrical propensity — Walking test

1 Scope

This International Standard specifies a method of evaluating the electrostatic propensity of textile and laminate floor coverings under controlled conditions. Since the potential generated varies with humidity, shoe materials, walk surface and individuals' mannerisms, the values generated by this test will not necessarily reflect actual field experience, but will provide a relative comparison of the performance of different surfaces.

For classification purposes and in cases of dispute, the measurement procedure specified in this International Standard can be used under controlled conditions specified in the relevant classification standard or agreed between disputing parties. There may be occasions where measurements are required under non-controlled conditions, e.g. *in situ* measurements on installed floor coverings. The principle of measurement using the equipment specified in this International Standard can be used to make measurements, either with the standard footwear specified or with specific footwear relevant to the end use.

2 Normative references

The following referenced documents are indispensable for the application of this document. For dated references, only the edition cited applies. For undated references, the latest edition of the referenced document (including any amendments) applies.

ISO 48:2010, *Rubber, vulcanized or thermoplastic — Determination of hardness (hardness between 10 IRHD and 100 IRHD)*

ISO 1957, *Machine-made textile floor coverings — Selection and cutting of specimens for physical tests*

ISO 2424, *Textile floor coverings — Vocabulary*

ISO 9407:1991, *Shoe sizes — Mondopoint system of sizing and marking*

ISO 10965:2011, *Textile floor coverings — Determination of electrical resistance*

3 Terms and definitions

For the purposes of this document, the terms and definitions given in ISO 2424 apply.

4 Principle

The difference in electrical potential, in relation to the earth's potential (zero), produced by a person walking

- a) on the floor covering under test,
- b) with standardized footwear,
- c) in a prescribed manner, and
- d) under controlled atmospheric conditions

is measured and used to evaluate the risk of a person experiencing the discomfort of static electrical shock from in-service use of this floor covering.

5 Apparatus

5.1 Grounded metal base plate

Grounded metal base plate, e.g. aluminium, of approximate dimensions 100 cm × 200 cm and 1 mm thick.

5.2 Rubber mat

For textile floor coverings: *rubber mat*, of approximate dimensions 220 cm × 120 cm and a minimal thickness of 3 mm, having a vertical resistance $\geq 10^{13} \Omega$ in relation to a surface area of 1 cm², measured at 500 V of direct current (d.c.) laid on a *grounded metal base plate*, e.g. aluminium, of approximate dimensions 100 cm × 200 cm and 1 mm thick.

Alternatively: *grounded metal base plate* (see 5.1).

5.3 Polyethylene foam (PE-foam)

For laminate floor coverings without attached sound-absorbing material: *PE-foam*, of approximate dimensions 220 cm × 120 cm and with a thickness of (3 ± 0,5) mm, having a vertical resistance $\geq 10^{13} \Omega$ in relation to a surface area of 1 cm², measured at 500 V of direct current (d.c.), laid on a *grounded metal base plate*, e.g. aluminium, of approximate dimensions 100 cm × 200 cm and 1 mm thick.

Alternatively: *grounded metal base plate* (see 5.1).

5.4 Polyethylene foil (PE-foil)

For laminate floor coverings with attached sound-absorbing material: *PE-foil* for water vapour barrier, of approximate dimensions 220 cm × 120 cm and with a thickness of (0,2 ± 0,1) mm, having a vertical resistance $\geq 10^{13} \Omega$ in relation to a surface area of 1 cm², measured at 500 V of direct current (d.c.), laid on a *grounded metal base plate*, e.g. aluminium, of approximate dimensions 100 cm × 200 cm and 1 mm thick.

Alternatively: *grounded metal base plate* (see 5.1).

5.5 Test sandals

Test sandals (see Figure A.1), reserved for use in this test method. The test sandals are open sandals of Mondopoint size 270/100 (see ISO 9407:1991) with no heels and with straps mounted to fit various foot sizes. A BAM rubber¹⁾ sole (Annex C) material has to be used. The resistance between the metal plate and the person standing on it wearing the sandals with the soles shall be $10^8 \Omega$ to $10^9 \Omega$.

Only for textile floor coverings: Alternatively, the sole material XS-664P Neolite²⁾ (Annex B) may be used. The resistance between the metal plate and the person standing on it wearing the sandals with the soles shall be $> 10^{11} \Omega$.

NOTE For guidance on the possible effect of the operator's clothing and other factors on test results, see Annex A.

5.6 Means of cleaning the sandals

5.6.1 Abrasive paper, from P280 to P360.

5.6.2 Scoured cotton cloth, free from finish or detergent.

1) The BAM rubber material is available from BAM, Berlin, Germany. This information is given for the convenience of users of this document and does not constitute an endorsement by ISO of the product. Equivalent products may be used if they can be shown to lead to the same results.

2) The Neolite material is available from AATCC, P.O. Box 12215, Research Triangle Park, NC 27709, USA. This information is given for the convenience of users of this document and does not constitute an endorsement by ISO of the product. Equivalent products may be used if they can be shown to lead to the same results.

5.6.3 Denatured ethanol or isopropanol

5.6.4 Demineralized water

5.7 Ionizing source

Ionizing source (e.g. ion blower), for discharging the test piece and rubber mat/PE-foam/PE-foil.

5.8 Body voltage measuring system

Body voltage measuring system (see Figure E.2), consisting of a d.c. static voltmeter, an autographic recorder and a hand electrode (see Figure E.3) meeting the following requirements:

- input resistance of voltmeter and hand electrode system: $\geq 10^{13} \Omega$;
- input capacitance of hand electrode: $\leq 20 \text{ pF}$;
- response time: $\leq 0,25 \text{ s}$;
- capable of measurements from -20 kV to $+20 \text{ kV}$.

5.9 Measuring devices for temperature and relative humidity

Measuring devices should meet the following requirements:

- resolutions: for temperature, $0,1 \text{ }^\circ\text{C}$ or better, and for relative humidity, $0,1 \%$ or better;
- uncertainty of measurement: for temperature, $\pm 0,5 \text{ }^\circ\text{C}$ or better, and for relative humidity, $\pm 2,0 \%$ or better.

6 Sampling and selection of specimens

6.1 Textile floor coverings

Carry out sampling and selection of specimens for textile floor coverings in accordance with ISO 1957. From each sample, select a specimen measuring $2\,000 \text{ mm} \times 1\,000 \text{ mm}$ in the machine production direction.

Generally, the test is performed on the floor covering as received, i.e. with finishes and special treatments as appropriate. If the permanency of such finishes and treatments is being investigated, the specimen may be submitted to a cleaning process or to practical wear conditions before testing.

6.2 Laminate

Carry out sampling and selection of specimens for laminate, trying to cover an area measuring $2\,000 \text{ mm} \times 1\,000 \text{ mm}$.

7 Preconditioning of specimens, PE-foam, PE-foil and rubber mats

Pre-condition the test specimen for at least 24 h in an atmosphere of $(23 \pm 3) \text{ }^\circ\text{C}$ and $(55 \pm 10) \%$ relative humidity.

If possible, ensure free air circulation by, for example, placing samples on a rack or suspending them.

The rubber mat (5.2), PE-foam (5.3), PE-foil (5.4) and sandals (5.5) shall not be used for any other purpose and should be permanently maintained in the test atmosphere. If this is not possible, the rubber mat, PE-foam, PE-foil and sandals shall be conditioned for 2 d prior to testing.

Care should be taken to ensure specimens and equipment are adequately conditioned, particularly where certain finishes can lead to slow conditioning.

8 Atmosphere for conditioning and testing

Condition the test piece at a temperature of (23 ± 2) °C and relative humidity of (25 ± 2) % for a minimum of 7 d, and maintain these conditions during testing. When the test is carried out *in situ*, record the ambient temperature and relative humidity.

NOTE Several standard atmospheres are specified by various regional authorities based upon the severity of conditions the floor covering normally experiences in service. Values determined under one set of conditions cannot be compared to those using another set of test conditions.

9 Test procedures

9.1 Preparation

9.1.1 Cleaning the sandals

9.1.1.1 BAM sandals

Before beginning a test series, scrub the BAM sole material using a piece of scoured cotton (5.6.2) wetted with ethanol or isopropanol (5.6.3) to remove any chemical substance from the surface. Repeat the cleaning procedure with demineralized water (5.6.4) until no dark marks appear on the cloth. Repeat the ethanol/isopropanol and water cleaning procedure prior to testing each specimen.

Wait at least 5 min and make sure the soles are completely dry before testing.

If the sole material becomes severely contaminated, it may be necessary to use more rigorous cleaning procedures prior to commencing a test series. Especially in the case of the BAM-soles, it is recommended to abrade the dry soles with a fine sandpaper (5.6.1) and then remove the dust. It is generally recommended to clean the sandals before each test series and before storing the soles at the end of the day.

9.1.1.2 Neolite sandals

Before beginning a test series, scrub the Neolite sole material using a piece of scoured cotton (5.6.2) wetted with ethanol or isopropanol (5.6.3) to remove any chemical substance from the surface. Wait at least 5 min and make sure the soles are completely dry before testing.

9.2 Method A: test procedure in laboratory conditions

9.2.1 Test procedure for textile floor coverings

9.2.1.1 Recording the testing atmosphere

Measure and record the temperature and humidity of the test chamber immediately before and after each test series, using the measurement device (5.9).

9.2.1.2 Discharging the specimen and testing materials

9.2.1.2.1 For textile floor coverings tested on the rubber mat

Eliminate any residual static charge using the ionizing source (5.5). Treat the rubber mat (5.2) in its operating position on the metal base plate (5.1) and the front and back of the specimen while it is hanging or standing freely. Carefully lay the specimen on the rubber mat, ensuring that it neither slides on the mat nor comes into contact with the metal base plate.

9.2.1.2.2 For textile floor coverings tested without the rubber mat

Eliminate any residual static charge using the ionizing source (5.5). Treat the front and back of the specimen while it is hanging or standing freely. Carefully lay the specimen on the metal base plate ensuring that it does not slide.

9.2.1.3 Performing the test

The operator shall place the BAM sandals or Neolite sandals on the specimen, then step into them. The sandals shall be fastened securely to ensure that the operator's feet remain in constant contact with the insoles of the sandals.

Eliminate any residual charge on the operator and sandals by connecting the operator to earth (zero potential) while wearing the sandals and standing on the specimen immediately prior to walking on the specimen.

The operator shall walk on the specimen at the rate of two steps per second while maintaining the body facing in the same direction throughout the test. The operator shall cover as much of the specimen as possible by walking forwards and backwards, but avoiding scuffing or pivoting. The stepping action should maintain the sole of the sandal parallel to the specimen at all times while lifting the sandal between 50 mm and 80 mm. The operator shall not come closer than 0,5 m to the wall or any object in the room, and shall continue walking until the peak voltage ceases to rise or for 60 s, whichever occurs first. The operator shall remove the sandals, clean the soles and repeat the procedures 9.1.1, 9.2.1.2, and 9.2.1.3 to complete a set of three walks on each specimen.

Specimens used in previous tests shall be stored so that any residual charge does not affect subsequent tests.

9.2.2 Test procedure for laminate floor coverings

9.2.2.1 Recording the testing atmosphere

Measure and record the temperature and humidity of the test chamber immediately before and after each test series, using the measurement device (5.9).

9.2.2.2 Discharging the specimen and testing materials

9.2.2.2.1 For laminate floor coverings without attached sound-absorbing material

Eliminate any residual static charge using the ionizing source (5.7). Treat the PE-foam (5.3) in its operating position on the metal base plate (5.1) and the front and back of the specimen while it is standing freely. Carefully lay the specimen on the PE-foam ensuring that it neither slides on the mat nor comes into contact with the metal base plate

9.2.2.2.2 For laminate floor coverings with attached sound-absorbing material

Eliminate any residual static charge using the ionizing source (5.7). Treat the PE-foil (5.4) in its operating position on the metal base plate (5.1) and the front and back of the specimen while it is standing freely. Carefully lay the specimen on the PE-foil ensuring that it neither slides on the mat nor comes into contact with the metal base plate.

9.2.2.3 Performing the test

The operator shall place the BAM sandals on the specimen, then step into them. The sandals shall be fastened securely to ensure that the operator's feet remain in constant contact with the insoles of the sandals.

Eliminate any residual charge on the operator and sandals by connecting the operator to earth (zero potential) while wearing the sandals and standing on the specimen immediately prior to walking on the specimen.

The operator shall walk on the specimen at the rate of two steps per second while maintaining the body facing in the same direction throughout the test. The operator shall cover as much of the specimen as possible by walking forwards and backwards, but avoiding scuffing or pivoting. The stepping action should maintain the sole of the sandal parallel to the specimen at all times while lifting the sandal between 50 mm and 80 mm. The operator shall not come closer than 0,5 m to the wall or any object in the room, and shall continue walking until the peak

voltage ceases to rise or for 60 s, whichever occurs first. The operator shall remove the sandals, clean the soles and repeat the procedures 9.1.1.1, 9.2.2.2 and 9.2.2.3 to complete a set of three walks on each specimen.

Specimens used in previous tests shall be stored so that any residual charge does not affect subsequent tests.

9.3 Method B: test procedure *in situ*

Record the ambient temperature and relative humidity, and the condition of the floor covering and, if relevant, any treatment prior to testing (e.g. cleaning, washing, etc.).

Place the sandals on the area of floor covering to be tested and perform the test as in 9.2.1.3 or 9.2.2.3, as appropriate.

10 Calculation and expression of results

From the recorder chart for every test walk, the arithmetic mean of the five highest valleys shall be determined and all results in kilovolts expressed to the nearest 0,1 kV.

Calculate the average, standard deviation and coefficient of variation (CV%) of the three walks.

NOTE 1 A common deviation from this calculation is used when the measuring system incorporates damping to reduce the difference between peaks and valleys on the recording trace. The mid-point of the chart trace when it reaches maximum value is determined visually. This practice gives slightly higher values than determining the "highest valleys".

NOTE 2 Increase the number of walks when there is a difference in algebraic signs until three results are obtained with the same algebraic sign.

11 Test report

The test report shall include the following information:

- a) a statement that the tests were performed according to this International Standard and the method used, i.e. ISO 6356, method A or B;
- b) the identification of each sample, including type of pretreatment (if any);
- c) the exact conditioning and testing atmosphere;
- d) underlay (e.g. metal base plate, rubber mat, PE-foam, PE-foil or combinations)
- e) sole type;
- f) the individual body voltages for each walk;
- g) the average, standard deviation and CV% of the sole generating the highest values of valleys;
- h) details of any deviations from this test method.

Annex A (normative)

Specification of the sandals

A.1 General

The sandals shall be Mondopoint size 270/100 (see ISO 9407:1991), with open toe, adjustable heel and instep strap on the forepart. These straps shall be lasted to the insole to which a wedge heel is attached and the whole provided with an outer sole made in one piece. A complete sock lining shall be stuck to the insole.

A stainless steel plate shall be inserted centrally near the front, and aluminium rivets inserted at both front and back to provide a conductive contact between outer sole and operator (see Figures A.1 and A.2). All rivets shall make good contact with either the outer sole or the steel plate at the bottom and the foot at the top.

A.2 Lasts

The sandals shall be made on lasts with a good fit. The last bottom, also called the "insole model", shall meet with the requirements of the insole pattern shown in Figure A.1, which also gives the positioning of the steel plate and aluminium rivets.

The upper part of the lasts shall be made so the footwear can be manufactured with a good fit for this specific purpose.

A.3 Materials

The materials required are given in Table A.1.

A.4 Construction procedure

The upper shall be composed of four straps positioned so the joint instep and heel of the foot are well enclosed. The straps shall be fastened by means of contact fastener tape (hook-and-loop fastener) fixed to the straps, in order that the sandal be adaptable to a wide range of foot sizes.

Attach the contact fastener tape to the straps by adhesion, then secure it with a single row of stitching. To avoid creasing, stick the upper leather and lining to one another in the fit of the last. Complete the uppers by trimming the straps and under edge, then finish all edges.

Press-cut the side of the insole to the right side and paint it. Cement-last the upper to the insole, then roughen the last margin and insole and remove all dust so a good base is formed for attaching the wedge and outer sole.

Attach the wedge heel to the lasted sandal, then stick the sock lining to the insole, since at this stage the steel plate and aluminium rivets are to be fitted. After attaching them, stick the sole under the sandals and finish the edges.

In order to ensure good contact, the heads of the aluminium rivets should not come into contact with the adhesive, either from above or below. It is essential there be direct contact between the foot and the aluminium rivets on one side and between the aluminium rivets and the outer sole or the steel plate on the other.

Table A.1 — Materials for the sandals

Material	Description
Upper leather	1,5 mm to 1,6 mm thick
Lining leather	1,2 mm to 1,4 mm thick
Sock lining	0,7 mm thick
Insole leather	3 mm thick
Contact fastener tape (hook-and-loop type)	30 mm wide
Stitching thread	R 75/3 type
Wedge heels	Microcel rubber, hardness approximately 60 IRHD (see ISO 48:2010)
Outer soles	a) Butt leather (allowing stitching and adhesive binding) b) Standardized sole material, see Annex B or C
Adhesion used for: — lining attachment; — sock lining; — attachment of Velcro ^a tape; — cement lasting; — attachment of wedge heel; — sole attachment.	Rubber adhesive Polyvinyl acetate emulsion adhesive Rubber adhesive Neoprene adhesive Neoprene adhesive Neoprene adhesive
Rivets	Blind aluminium rivets, flat-headed, approximately 9 mm diameter head: — front, 4 mm diameter × 7,4 mm length with cadmium-plated washer, 9 mm diameter, 4,2 mm hole, 0,6 mm thick; — heel, 4,8 mm diameter × 25,4 mm length with cadmium-plated washer, 12 mm diameter, 5,2 mm hole, 0,7 mm thick.
^a Velcro is an example of a suitable product available commercially. This information is given for the convenience of users of this document and does not constitute an endorsement by ISO of this product.	

.....

Dimensions in millimetres

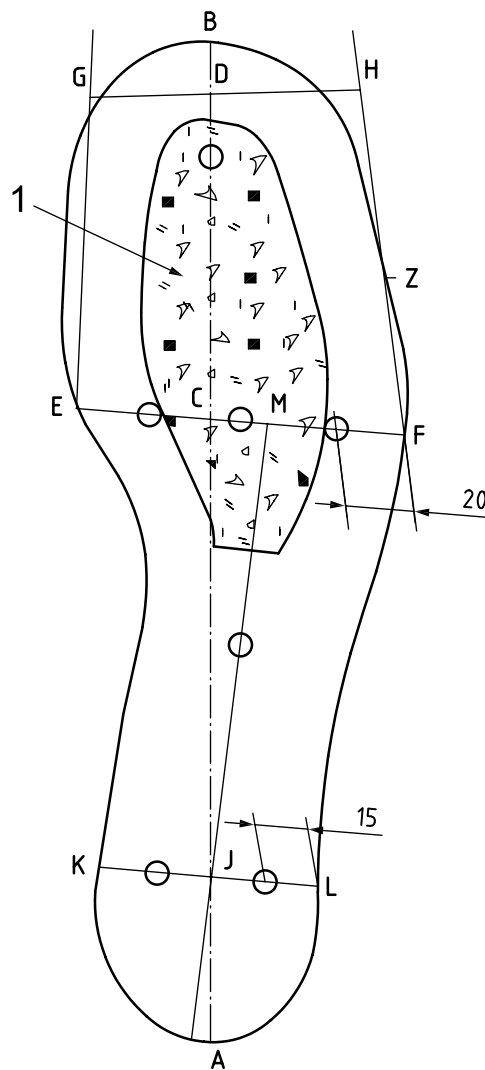

Key

- position of blind rivets
- 1 stainless steel

Figure A.1 — Insole pattern

Table A.2 — Dimensions of the insole pattern

Dimensions in millimetres

Line designation	Length of lines	Line designation	Length of lines		
AD	Length of foot	273	EF	Joint width	94
BD	Normal allowance	15	HZ	One-fifth of AD	55
AB	Length of last	288	EM	60 % of EF	56
AC	62 % of AB	179	AJ	One sixth of AD	46
BC	38 % of AB	109	KJ	One-third of EF	31
EC	One-sixth of joint girth	42	LJ	One-third of EF	31
FC	One-sixth of joint girth plus 26 % of one-sixth of joint girth	52	KL	Heel width	63

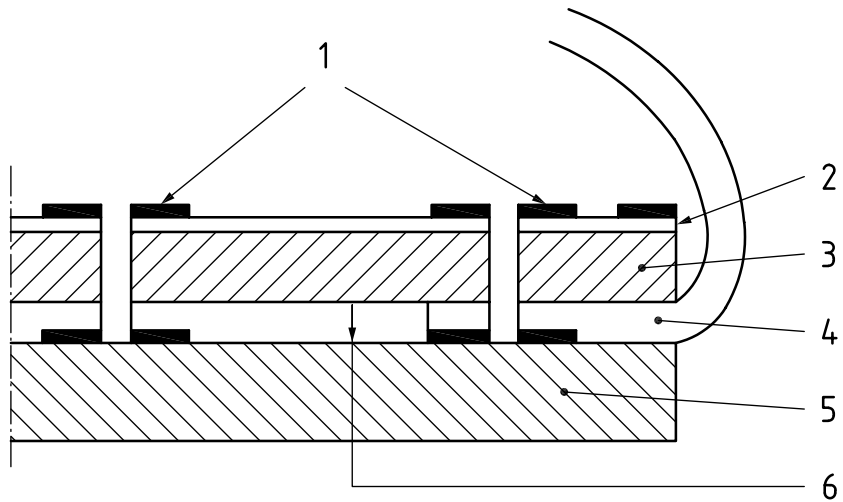

Key

- 1 hollow rivets
- 2 sock lining
- 3 insole
- 4 leather strap
- 5 outsole
- 6 stainless steel

Figure A.2 — Positioning of blind rivets and steel plate

Annex B (normative)

Standard sole material — Neolite (standard XS-664P)

B.1 Specification

Standard cold, non oil-extended, styrene butadiene rubber, with fillers (25 % aluminium magnesium silicate, 10 % wood fibre).

Processing additives: zinc oxide, stearic acid, petroleum base resin, antioxidant, sulfur (for vulcanization) and trace of colorants.

The exact formula is adjusted at each test to conform to the reference established by Goodyear in 1950.

NOTE This limited specification is reproduced by permission of the Goodyear Tire and Rubber Company. The standard XS-664 Neolite is only available from AATCC (see footnote 2).

B.2 Physical properties

Surface hardness	93 to 96 Durometer A
Relative density	$1,23 \pm 0,02$
Thickness	3,18 mm
Vertical resistivity (Annex D)	$> 10^{11} \Omega$ (ISO 10965:2011)
Elongation at break	$375 \% \pm 25 \%$
Values checked at	$23 \text{ }^\circ\text{C} \pm 1 \text{ }^\circ\text{C}$

B.3 Mounting procedure

The rubber shall be attached to the bottom surface of the sandal with the rough side next to the sandal and the smooth side as the wear surface.

It is necessary to remove the outer layer of any new sole material before use because this layer may contain residual substances from the production process.

Annex C (normative)

Standard sole material — BAM-rubber

C.1 Specification

Composition	Parts by mass
Natural rubber (TSR-L)	100
2,2'-Dibenzothiazol disulfide	1,8
<i>N</i> -Isopropyl- <i>N'</i> -phenyl- <i>p</i> -phenylene diamine	1,0
Stearic acid	1,0
Zinc oxide	Class B4c (see ISO 9298:1995, Annex D) 50,0
Carbon black HAF	ASTM N 330 25 to 29
Sulfur	2,5

Treatment: vulcanization at 150 °C for 18 min.

C.2 Physical properties

Surface hardness	58 ± 3 Shore A (ISO 7619-1)
Relative density	1,33 ± 0,02 (ISO 2781)
Thickness	3,0 ± 0,5 mm
Vertical resistivity (Annex D)	10 ⁸ to 10 ⁹ Ω (ISO 10965:2011)

Annex D (normative)

Method for measuring the electrical resistance of the footwear

Calibrated high resistance meter, having changeable nominal open circuit voltages of 500 V and 100 V and a short circuit current limited to 10 mA capable of reading resistances from $1 \times 10^3 \Omega$ to $1 \times 10^9 \Omega$ to an accuracy of $\pm 5 \%$ and resistances over $1 \times 10^9 \Omega$ to an accuracy of $\pm 10 \%$.

$$R = \frac{U}{I}$$

One metal electrode (preferably stainless steel), with terminals to make connections to the resistance meter. The electrode shall weigh a total of $(5 \pm 0,1)$ kg, and shall have a flat circular contact area of (65 ± 5) mm in diameter.

Non-conductive plate (e.g. made of PMMA or PTFE), of dimensions (300 ± 10) mm \times (300 ± 10) mm with a vertical resistance of minimum $(1 \times 10^{13}) \Omega$ measured.

Earthed metal plate, of dimensions (300 ± 1) mm \times (300 ± 1) mm with an electrical terminal at one side.

The electrical resistance through the standard sandals shall be determined by carrying out the following procedure on each sandal.

Place the earthed metal plate on the insulating plate. Make sure that any charges are eliminated.

Put the specimen with its face uppermost on the metal plate. Place the electrode on the first part of the sandal in such a way that it connects the three rivets, as shown in Figure D.1. Connect the electrode and the metal plate to the resistance meter.

Make two measurements and take the readings 15 s after applying the potential to the electrodes.

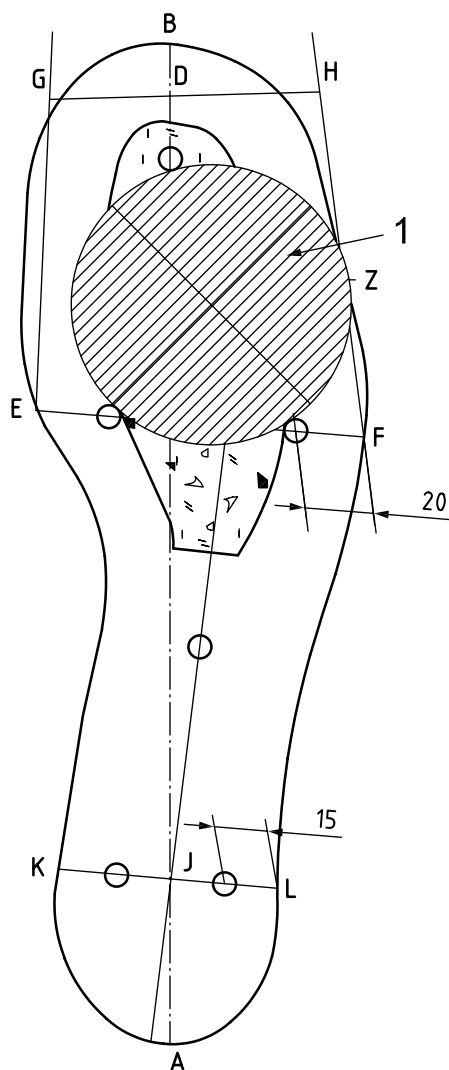

Key
 1 electrode

Figure D.1 — Measurement of electrical resistance

Annex E (normative)

Example of a hand-held electrode and its use

Diagrams of a suitable hand electrode are shown in Figures E.1, E.2 and E.3.

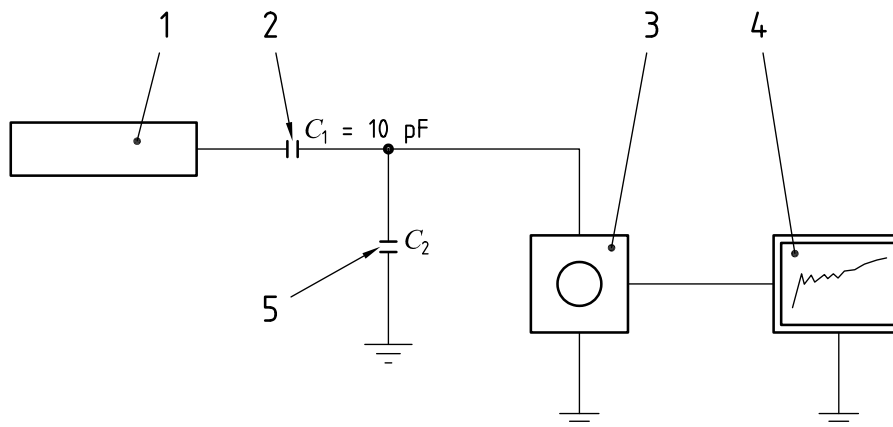

Key

- 1 hand electrode
- 2 hand electrode capacitance reading
- 3 static voltmeter
- 4 autographic recorder
- 5 divider capacitance reading

Figure E.1 — Representation of total system

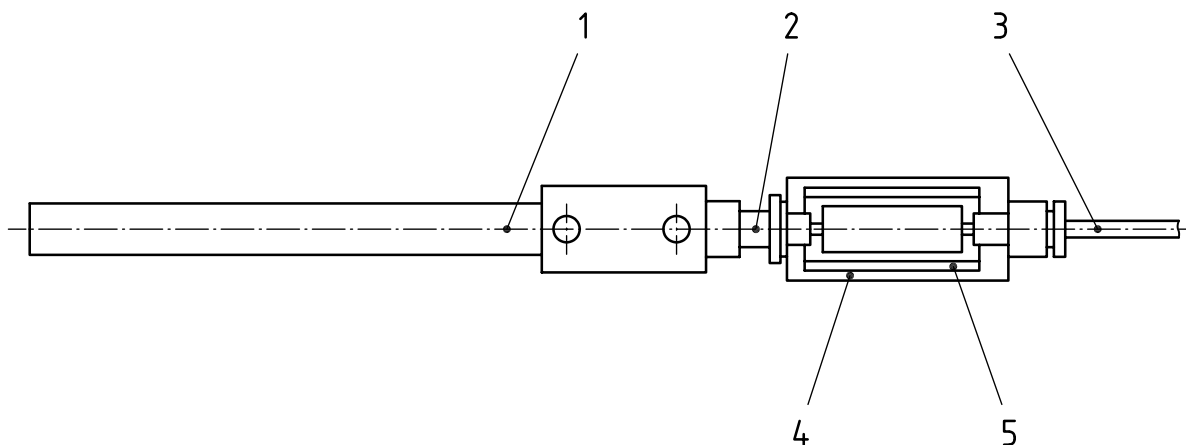

Key

- 1 hand electrode
- 2 BNC connector
- 3 coaxial cable to static voltmeter
- 4 voltage divider housing
- 5 condenser C_2 , earthed via voltage divider housing

Figure E.2 — Hand-held voltage divider

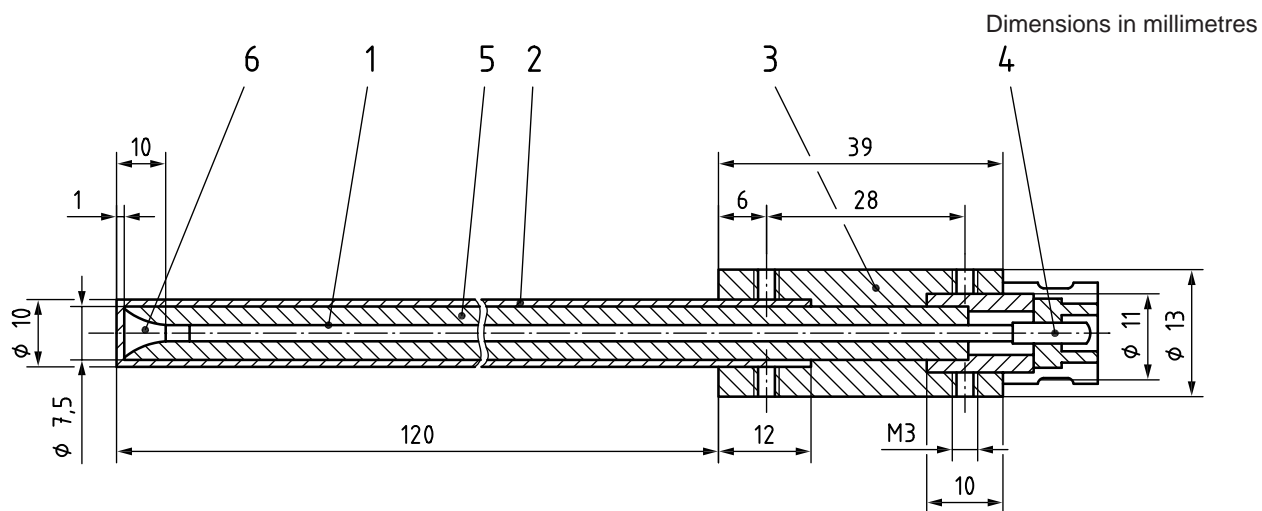

Key

- 1 cable core
- 2 metal tubing
- 3 PTFE sleeve
- 4 BNC (bayonet) plug
- 5 coaxial cable
- 6 polyethylene plug

Figure E.3 — Hand electrode

Annex F (informative)

Method of checking calibration of the measuring system

F.1 Static calibration

The measuring system zero voltage point is checked by connecting the hand electrode to an earth point. The system is then checked for voltage measurement by connecting the hand electrode to an output terminal of a stable d.c. voltage supply. Voltages of 1 kV, 2 kV and 3 kV shall be confirmed.

Bibliography

- [1] ISO 2781, *Rubber, vulcanized or thermoplastic — Determination of density*
- [2] ISO 7619-1, *Rubber, vulcanized or thermoplastic — Determination of indentation hardness — Part 1: Durometer method (Shore hardness)*
- [3] ISO 9298:1995, *Rubber compounding ingredients — Zinc oxide — Test methods*

ICS 59.080.60

Price based on 18 pages