**Road vehicles — Brake linings — Shear
test procedure for disc brake pad and
drum brake shoe assemblies**

*Véhicules routiers — Garnitures de freins — Méthode d'essai de
cisaillement des ensembles de plaquettes de freins à disque et
segments de freins à tambour*



PDF disclaimer

This PDF file may contain embedded typefaces. In accordance with Adobe's licensing policy, this file may be printed or viewed but shall not be edited unless the typefaces which are embedded are licensed to and installed on the computer performing the editing. In downloading this file, parties accept therein the responsibility of not infringing Adobe's licensing policy. The ISO Central Secretariat accepts no liability in this area.

Adobe is a trademark of Adobe Systems Incorporated.

Details of the software products used to create this PDF file can be found in the General Info relative to the file; the PDF-creation parameters were optimized for printing. Every care has been taken to ensure that the file is suitable for use by ISO member bodies. In the unlikely event that a problem relating to it is found, please inform the Central Secretariat at the address given below.



COPYRIGHT PROTECTED DOCUMENT

© ISO 2010

All rights reserved. Unless otherwise specified, no part of this publication may be reproduced or utilized in any form or by any means, electronic or mechanical, including photocopying and microfilm, without permission in writing from either ISO at the address below or ISO's member body in the country of the requester.

ISO copyright office
Case postale 56 • CH-1211 Geneva 20
Tel. + 41 22 749 01 11
Fax + 41 22 749 09 47
E-mail copyright@iso.org
Web www.iso.org

Published in Switzerland

Contents

Page

Foreword	iv
Introduction	v
1 Scope	1
2 Normative references	1
3 Terms and definitions	1
4 Symbols and units	2
5 Sampling and conditioning	2
6 Test rig and fixtures	2
6.1 Test rig	2
6.2 Fixtures	3
7 Test procedure	5
8 Calculation of shear strength	6
9 Presentation of results	6
Annex A (normative) Test procedure flowchart	8
Annex B (informative) Test report	10
Bibliography	11

Foreword

ISO (the International Organization for Standardization) is a worldwide federation of national standards bodies (ISO member bodies). The work of preparing International Standards is normally carried out through ISO technical committees. Each member body interested in a subject for which a technical committee has been established has the right to be represented on that committee. International organizations, governmental and non-governmental, in liaison with ISO, also take part in the work. ISO collaborates closely with the International Electrotechnical Commission (IEC) on all matters of electrotechnical standardization.

International Standards are drafted in accordance with the rules given in the ISO/IEC Directives, Part 2.

The main task of technical committees is to prepare International Standards. Draft International Standards adopted by the technical committees are circulated to the member bodies for voting. Publication as an International Standard requires approval by at least 75 % of the member bodies casting a vote.

Attention is drawn to the possibility that some of the elements of this document may be the subject of patent rights. ISO shall not be held responsible for identifying any or all such patent rights.

ISO 6312 was prepared by Technical Committee ISO/TC 22, *Road vehicles*, Subcommittee SC 2, *Braking systems and equipment*.

This third edition cancels and replaces the second edition (ISO 6312:2001), which has been technically revised.

Introduction

The shear property relates to stresses at the area of contact between lining and carrier in disc brake pad and drum brake shoe assemblies.

The specification for the average rate of load and the recommendation for variations in the instantaneous rate of load given in this International Standard take into account current practice, based upon an examination of equipment in use.

This third edition of this International Standard incorporates technical updates generated in the course of harmonization efforts during the development of ISO 15484.

11/15/2019 10:00 AM

Road vehicles — Brake linings — Shear test procedure for disc brake pad and drum brake shoe assemblies

1 Scope

This International Standard specifies a method for measuring the strength of the bond connection between the lining material and the carrier in disc brake pad and drum brake shoe assemblies (shear strength). This International Standard is applicable to assemblies that are integrally moulded, bonded or that use mechanical retention systems (MRS) of both types used for brakes on road vehicles. This International Standard does not apply to riveted assemblies.

2 Normative references

The following referenced documents are indispensable for the application of this document. For dated references, only the edition cited applies. For undated references, the latest edition of the referenced document (including any amendments) applies.

ISO 611, *Road vehicles — Braking of automotive vehicles and their trailers — Vocabulary*

3 Terms and definitions

For the purposes of this document, the terms and definitions given in ISO 611 and the following apply.

3.1

lining

friction material component of a brake lining assembly

3.2

carrier

component of a brake lining assembly to which the friction material is attached

3.3

bond area

A

contact area between lining and carrier

3.4

mechanical retention system

MRS

attachment method where mechanical protrusions on the backing plate aid the retention of the friction material or the underlayer

3.5

shear force at failure

F

total load applied at the time of shear failure

3.6
shear strength at failure

τ
ratio of the load at failure divided by the bond area

4 Symbols and units

The symbols and preferred units used in this International Standard are given in Table 1. See Clause 8.

Table 1 — Symbols and units

Quantity	Symbol	Unit
Shear force at failure	F	N
Bond area	A	mm ²
Shear strength at failure	τ	MPa

5 Sampling and conditioning

This procedure can also apply for samples during product development, on finished products, or after special treatment (such as that covered by ISO 6314) or usage (inertia-dynamometer testing or field use) with the appropriate preparation.

Perform the testing on a complete assembly or a section (coupon) of the assembly. When testing a section or coupon, apply the load in the radial or tangential direction relative to the vehicle mounting position. Indicate the test orientation on the test report.

If needed, prepare the sample edges to ensure good contact with the loading and fixed tools. Remove noise insulating shims before the test.

When testing a lined shoe, the test area may cover the full assembly or segments of an assembly confined by saw cutting down to the carrier (see Figure 1).

Use five samples for standard testing.

NOTE The test procedure applies a load in a direction that might not be in accordance with the loading direction of the product in service. A high aspect ratio, chamfered, or slotted pads might influence the shear behaviour of the pad assembly.

6 Test rig and fixtures

6.1 Test rig

The test rig shall be a compression or tensile testing machine or similar (shear testing) machine of sufficient capacity to apply the shearing load by activating a ram.

The test rig shall provide equipment to register the exact load applied at the instant of shear failure.

The load application rate shall be controlled in such a way that the load increases at an average rate of (4 500 ± 1 000) N/s (as determined from typical vehicle-based evaluation). If a constant crosshead speed machine is being used, the load rate shall be set to (10 ± 1) mm/min. Indicate on the test report the type of machine control (load rate or crosshead speed) used for the test, so that it allows comparisons of results between different test rigs. Avoid any shock loading during the test.

Dimensions in millimetres

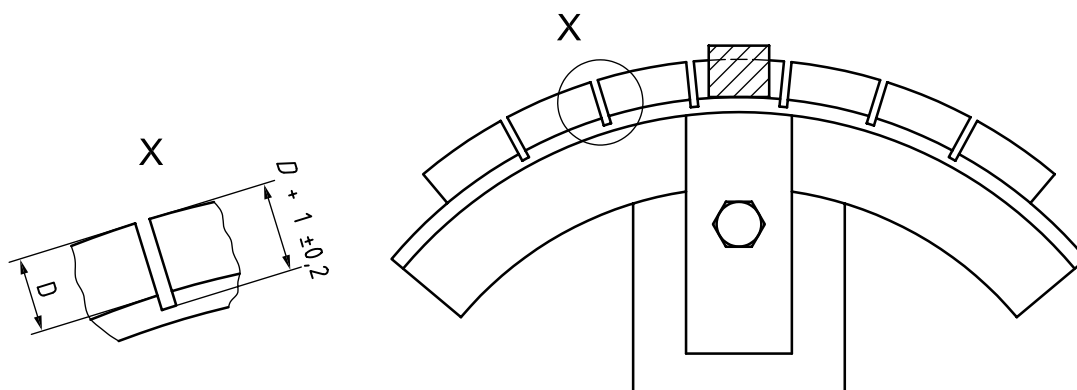

Figure 1 — Lined shoe in segmental test condition

6.2 Fixtures

6.2.1 General

The shearing test fixture shall have the means to hold a test sample such that it is parallel to the loading tool. To avoid sharp edges, this tool shall have a radius of 2 mm or less at the part in contact with the test sample. If a specific radius is used, note it on the test report as a deviation from the test procedure. If the surface area of the loading tool includes the draft angle of the friction material, note it on the test report.

6.2.2 Drum brake shoe assembly

The fixture (see Figure 2) shall be designed so that the loading tool is in contact with the edge of the lining for the full sample length and thickness within $(1 \pm 0,2)$ mm of the shoe platform.

The load application on the loading tool shall be in a direction parallel to the plane of the shoe platform. Support the shoe to maintain uniform loading along the length of the lining sample.

The width of the loading tool shall be greater than the width, W , of the lining.

6.2.3 Disc brake pad

Design the test fixture (see Figure 3) such that:

- the location of the plane of the backplate is parallel to the plane of the loading tool;
- the loading tool is in contact with the edge of the lining within $(1 \pm 0,2)$ mm of the backing plate (carrier) and conforms to the sample lining profile, including as optional draft angles from the moulding process;
- the loading tool is self-aligning;
- the loading tool is in contact with the full sample length of the lining edge parallel to the backplate support;
- the load-bearing edge of the backing plate rests against a rigid support with a thickness no greater than that of the backing plate;
- in order to prevent assembly movement under testing, a pressure fixture applies a face load of $(0,5 \pm 0,15)$ N/mm² of the lining area at a right angle to the shear load;
- the face load is applied in such a way that friction force is minimized and does not significantly influence the shear load measurement.

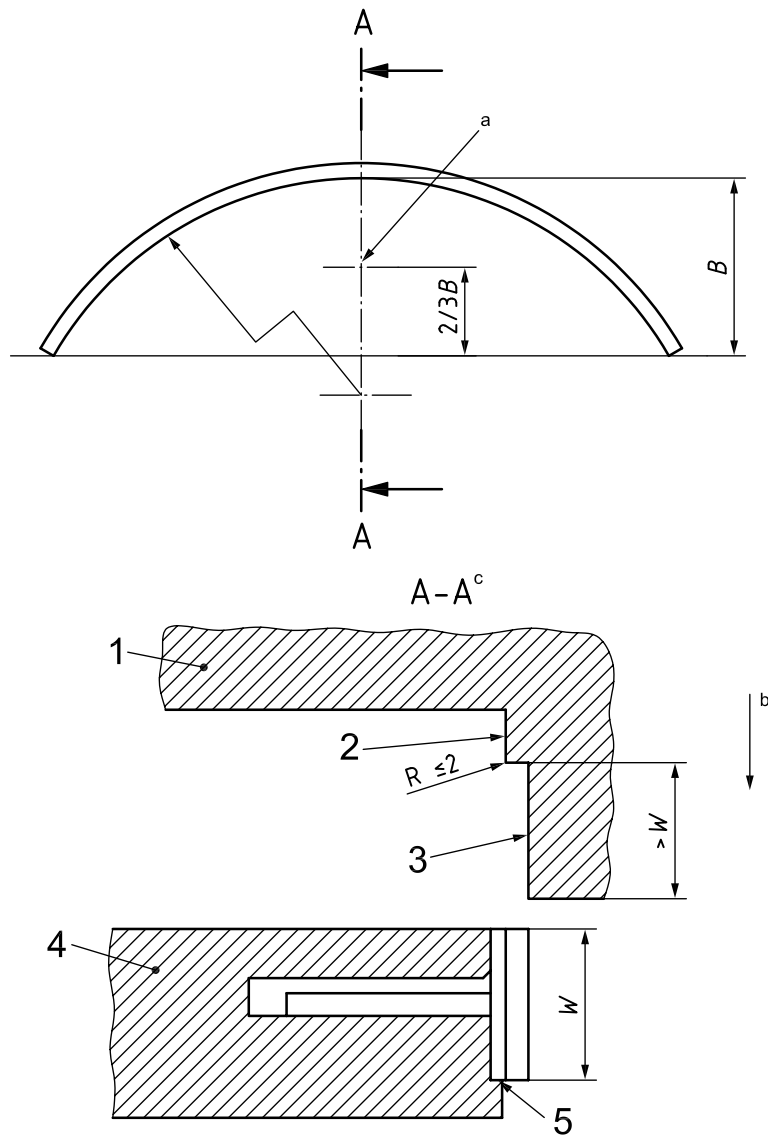

Key

- 1 loading tool
- 2 loading punch profile, $(1 \pm 0,2)$ mm clear off shoe platform
- 3 lining face support
- 4 fixed bottom tool
- 5 shoe platform supported by tool (support \leq platform thickness)
- a Centre of thrust of top ram to be positioned thus.
- b Loading direction, parallel to shoe platform.
- c Through test tool.

Figure 2 — Drum brake shoe test fixture

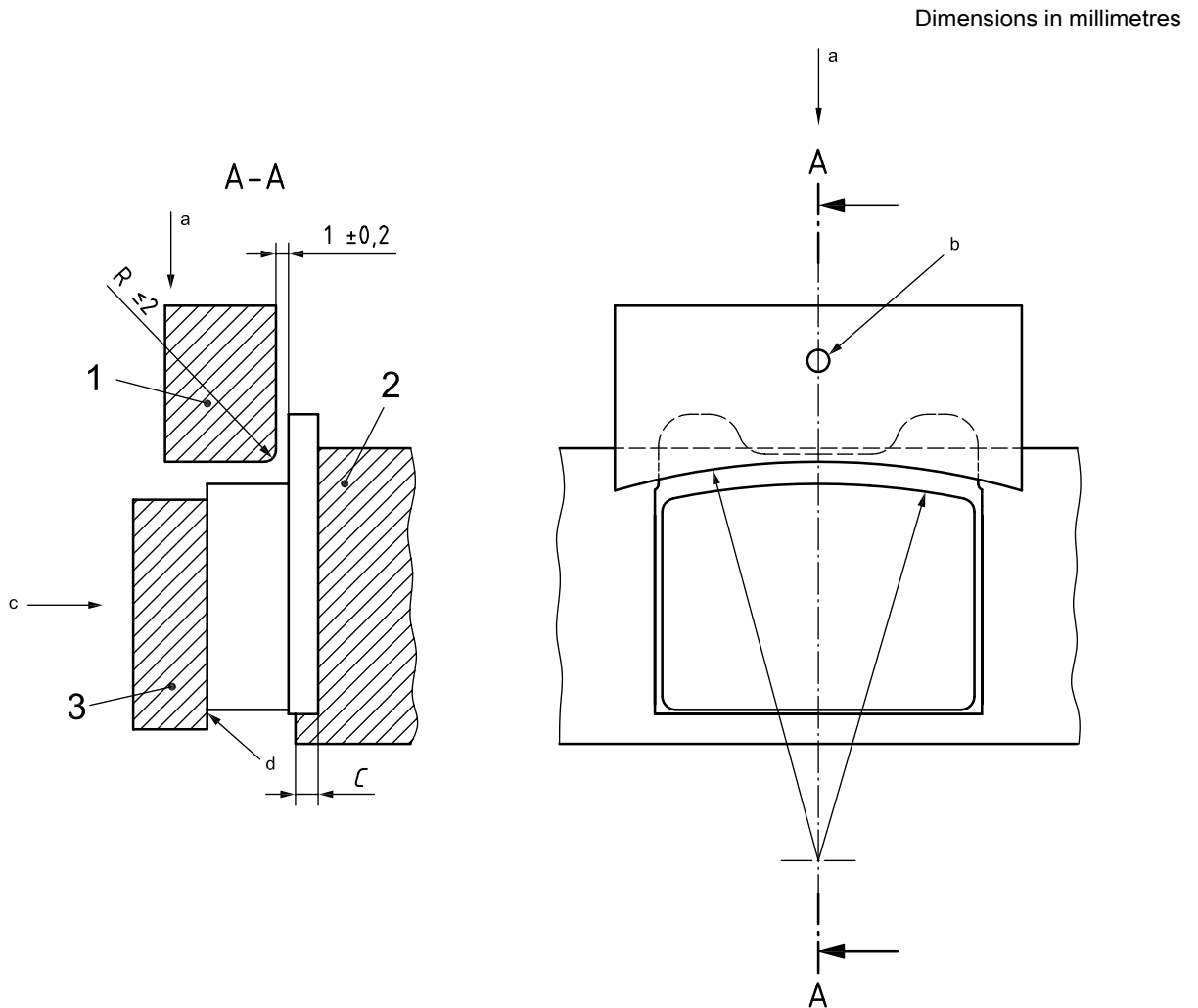

Key

- 1 loading tool (parallel to backing plate support)
- 2 backing plate support
- 3 face load fixture
- $C \leq$ backplate thickness
- a Direction of shear force.
- b Pivot.
- c Face load.
- d Minimized friction at interface.

Figure 3 — Disc brake pad test fixture

7 Test procedure

Carry out the test procedure as described below (Figure A.1 provides a flowchart of the test procedure).

- a) Conduct the test at ambient temperature $(23 \pm 5) ^\circ\text{C}$. Agree with customer prior to testing for other ambient conditions.
- b) When conducting a shear tests at elevated temperatures, heat the sample uniformly to the bond line temperature within 30 min and test 60 s after removal from the heating unit. Recommended temperatures are $(200 \pm 10) ^\circ\text{C}$ for drum brake linings and $(300 \pm 10) ^\circ\text{C}$ for disc pads.

- c) Place the brake shoe or disc brake pad in the appropriate shear-test fixture in the orientation indicated for the test (radial or tangential).
- d) Apply the load at the rate specified in 6.1, continuing until complete failure occurs.
- e) (Optional) Record the failure load together with the shear pattern expressed as a percentage as specified in Clause 9. Assess the fracture surface of uncut edges (2 mm from the friction pad or brake shoe outline) and core zones separately. If a visual assessment is doubtful, perform (optional to the test requestor) an analysis with a reference solution as described below.
 - 1) Prepare 1,0 l of reference solution by mixing:
 - 80 g of CuSO_4 ;
 - 30 g of NaCl;
 - 100 ml of 0,01 N hydrochloric acid (0,364 6 g HCl in a 1,0 l solution);
 - add distilled water or de-ionized water to obtain a total solution volume of 1,0 l.
 - 2) Immerse the backplate in the reference solution for 5 s.
 - 3) Assess the fracture condition and record as follows:
 - a material has fractured when the fracture surface is not coloured brown by the reference solution;
 - if there is a bonding fault between the glue and the backplate, there will be a regular and homogeneous brown colouring at the surface of fracture.

8 Calculation of shear strength

Calculate the shear strength, τ , using Equation (1), as follows:

$$\tau = \frac{F}{A} \tag{1}$$

Calculate A from the friction material profile at the bond line and not at the pad face, as chamfers or slots are pad surface effects.

Report the shear strength as the minimum and the average of the results of the number of samples tested.

9 Presentation of results

The test report (see Annex B) shall include the following information:

- a) type and supplier of the brake shoe assembly or disc brake pad friction material, and batch identification;
- b) sample type and load orientation when testing using a section or coupon;
- c) number of samples tested (five recommended);
- d) minimum and average shear force, or minimum and average shear strength, values, or both;
- e) loading tool with/without taper angle from moulding process;

- f) a description of the shear pattern, based on:
 - 1) percentage failure:
 - exposing the clean carrier,
 - within adhesive layer,
 - within the lining or underlayer,
 - 2) location of any clean carrier areas;
- g) comments (including mention of samples used as specified in Clause 5) on deviations from normal test conditions, such as a special test temperature.



Annex A
(normative)

Test procedure flowchart

Figure A.1 shows a flowchart of the test procedure.

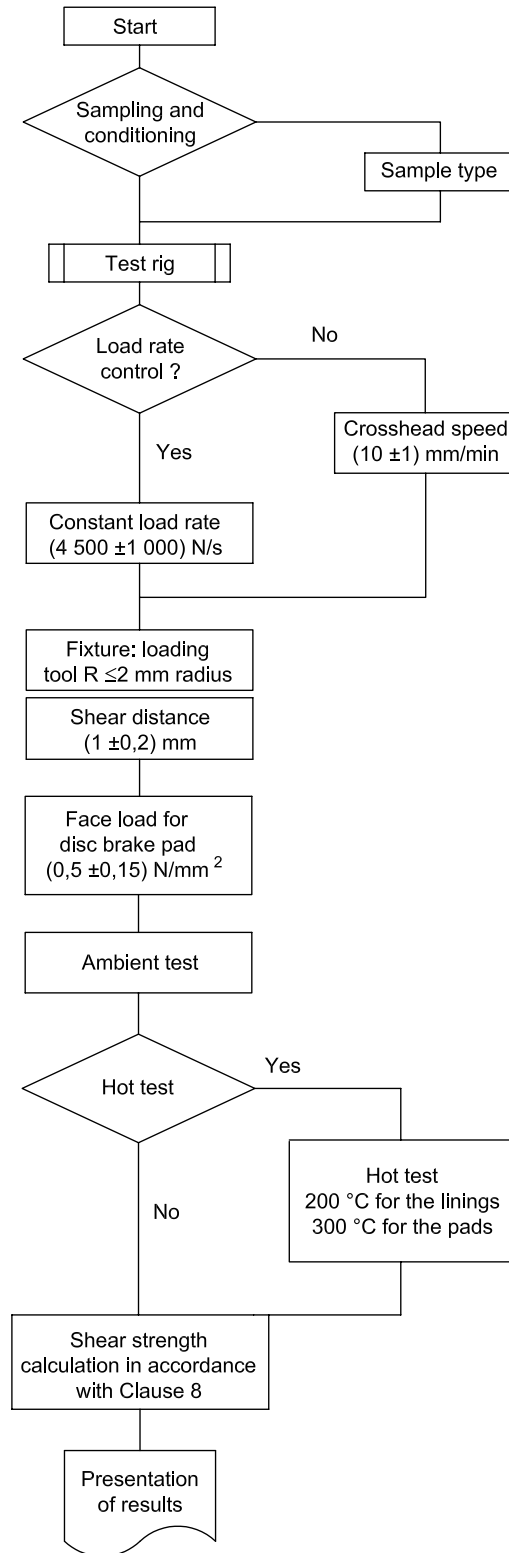

Figure A.1 — Test procedure flowchart

Annex B
(informative)

Test report

The presentation of the test parameters and report of results is given in Table B.1.

Table B.1 — Test parameters and report of results

Parameter	Constant load		Speed transverse load		
Load rate	(4 500 ± 1 000) N/s		(10 ± 1) mm/min		
Distance from carrier to loading tool	(1 ± 0,2) mm		(1 ± 0,2) mm		
Loading tool radius	< 2 mm		< 2 mm		
Loading tool draft angle (tick box)	<input type="checkbox"/> with	<input type="checkbox"/> without	<input type="checkbox"/> with	<input type="checkbox"/> without	
Face load	(0,5 ± 0,15) N/mm ²		(0,5 ± 0,15) N/mm ²		
Heating test					
Heating duration	30 min		30 min		
Test dwell time after heating	60 s		60 s		
Test temperature for drum brake lining	(200 ± 10) °C		(200 ± 10) °C		
Test temperature for disc brake pads	(300 ± 10) °C		(300 ± 10) °C		
Manufacturer of lining					
Lining reference					
Batch identification					
Sample type (tick box)	<input type="checkbox"/> full pad	<input type="checkbox"/> pad section or coupon	<input type="checkbox"/> full lined shoe	<input type="checkbox"/> segment of lined shoe	<input type="checkbox"/> other
Sample orientation for pad section or coupon testing (tick box)	<input type="checkbox"/> load in the radial direction		<input type="checkbox"/> load in the tangential direction		
Sample size					
Sample area at point of shear	mm ²				
Special coatings					
Ambient test			Hot test		
Number of samples tested (five recommended):			Number of samples tested (five recommended):		
Minimum shear strength:	MPa		Minimum shear strength:		MPa
Mean shear strength:	MPa		Mean shear strength:		MPa
Failure mode					
Clean carrier:		%	Clean carrier:		%
Adhesive:		%	Adhesive:		%
Failure in lining:		%	Failure in lining:		%
Location of clean areas:			Location of clean areas:		
Deviation from test procedure:					
Test date:					
Name of tester:					
Reference No.:					

Bibliography

- [1] ISO 6314, *Road vehicles — Brake linings — Resistance to water, saline solution, oil and brake fluid — Test procedure*
- [2] ISO 15484, *Road vehicles — Brake lining friction materials — Product definition and quality assurance*

ICS 43.040.40

Price based on 11 pages