**Paints and varnishes — Determination of
resistance to humidity —**

**Part 2:
Procedure for exposing test specimens in
condensation-water atmospheres**

Peinture et vernis — Détermination de la résistance à l'humidité —

*Partie 2: Méthode d'exposition d'éprouvettes à des atmosphères d'eau
de condensation*



Reference number
ISO 6270-2:2005(E)

© ISO 2005

PDF disclaimer

This PDF file may contain embedded typefaces. In accordance with Adobe's licensing policy, this file may be printed or viewed but shall not be edited unless the typefaces which are embedded are licensed to and installed on the computer performing the editing. In downloading this file, parties accept therein the responsibility of not infringing Adobe's licensing policy. The ISO Central Secretariat accepts no liability in this area.

Adobe is a trademark of Adobe Systems Incorporated.

Details of the software products used to create this PDF file can be found in the General Info relative to the file; the PDF-creation parameters were optimized for printing. Every care has been taken to ensure that the file is suitable for use by ISO member bodies. In the unlikely event that a problem relating to it is found, please inform the Central Secretariat at the address given below.

© ISO 2005

All rights reserved. Unless otherwise specified, no part of this publication may be reproduced or utilized in any form or by any means, electronic or mechanical, including photocopying and microfilm, without permission in writing from either ISO at the address below or ISO's member body in the country of the requester.

ISO copyright office
Case postale 56 • CH-1211 Geneva 20
Tel. + 41 22 749 01 11
Fax + 41 22 749 09 47
E-mail copyright@iso.org
Web www.iso.org

Published in Switzerland

Contents

Page

Foreword.....	iv
Introduction	v
1 Scope	1
2 Normative references	1
3 Designation	1
4 General.....	1
5 Apparatus	2
6 Procedure	4
7 Evaluation.....	5
8 Test report	6

Foreword

ISO (the International Organization for Standardization) is a worldwide federation of national standards bodies (ISO member bodies). The work of preparing International Standards is normally carried out through ISO technical committees. Each member body interested in a subject for which a technical committee has been established has the right to be represented on that committee. International organizations, governmental and non-governmental, in liaison with ISO, also take part in the work. ISO collaborates closely with the International Electrotechnical Commission (IEC) on all matters of electrotechnical standardization.

International Standards are drafted in accordance with the rules given in the ISO/IEC Directives, Part 2.

The main task of technical committees is to prepare International Standards. Draft International Standards adopted by the technical committees are circulated to the member bodies for voting. Publication as an International Standard requires approval by at least 75 % of the member bodies casting a vote.

Attention is drawn to the possibility that some of the elements of this document may be the subject of patent rights. ISO shall not be held responsible for identifying any or all such patent rights.

ISO 6270-2 was prepared by Technical Committee ISO/TC 35, *Paints and varnishes*, Subcommittee SC 9, *General test methods for paints and varnishes*.

ISO 6270 consists of the following parts, under the general title *Paints and varnishes — Determination of resistance to humidity*:

- *Part 1: Continuous condensation*
- *Part 2: Procedure for exposing test specimens in condensation-water atmospheres*

Introduction

ISO 6270 is intended to give consistent conditions and procedures for the conditioning of pre-prepared test specimens which are to be evaluated for defects which may develop when they are subjected to humid ambient atmospheres such as constant condensation-water atmospheres or alternating condensation-water atmospheres.

The tests are designed to clarify the behaviour of the test specimens in humid ambient atmospheres, and to pinpoint any defects in the protection of the test specimens against corrosion. The testing of coatings in these atmospheres does not necessarily give lifetime prediction data.

After conditioning, the test specimens are evaluated either in accordance with agreed International Standards, such as the appropriate part(s) of ISO 4628, *Paints and varnishes — Evaluation of degradation of coatings — Designation of quantity and size of defects, and of intensity of uniform changes in appearance*, or by procedures agreed between the interested parties.

.....

Paints and varnishes — Determination of resistance to humidity —

Part 2: Procedure for exposing test specimens in condensation-water atmospheres

1 Scope

This part of ISO 6270 describes the general conditions and procedures which need to be observed when testing coated test specimens in constant condensation-water atmospheres or in alternating condensation-water atmospheres, in order to ensure that the results of tests carried out in different laboratories are reproducible.

NOTE The shape and preparation of the test specimens, the duration of the test and the assessment of the test results are not covered in this part of ISO 6270.

2 Normative references

The following referenced documents are indispensable for the application of this document. For dated references, only the edition cited applies. For undated references, the latest edition of the referenced document (including any amendments) applies.

ISO 3270, *Paints and varnishes and their raw materials — Temperatures and humidities for conditioning and testing*

3 Designation

The condensation-water test atmospheres are designated as follows:

Test atmosphere	CH	Condensation atmosphere with constant humidity
	AHT	Condensation atmosphere with alternating humidity and air temperature
	AT	Condensation atmosphere with alternating air temperature

4 General

Condensation-water test atmospheres promote the condensation of atmospheric humidity on the surfaces of test specimens, the temperatures of which are lower than the temperature of the saturated air in the climatic chamber, due to radiation onto the chamber walls or to the cooling of the test specimen.

The atmospheric temperature in the climatic chamber during the condensation process described in this part of ISO 6270 is 40 °C.

The condensation-water test atmosphere may be either a constant-humidity (CH) or an alternating (AHT, AT) atmosphere. If, in addition to the action of the condensation water, the change in atmospheric temperature and the change in atmospheric humidity have an important effect on the test specimens, an alternating atmosphere should be chosen.

The quantity of condensation water formed on the surface of the coating may also exercise an important influence on the action of the water; this quantity will be affected by the ambient temperature in the installation room or by the cooling of the test specimen.

The condensate which drips off the test specimens consists of condensation water and also in some instances of solid and liquid constituents of the coating dissolved in the condensation water or mixed with it.

Reproducible results can only be expected if the test procedure and test conditions remain constant for a series of tests.

In the case of alternating atmospheres, a cycle time of 24 h shall be used as a general rule. A shorter cycle time (12 h or 16 h) and a correspondingly shortened time for the two test periods may be used for the AT test atmosphere.

A summary of test atmospheres, cycle durations and conditions is given in Table 1. Other cycles may be used by agreement between the interested parties.

Table 1 — Condensation test atmospheres

Test atmosphere		Cycle duration		Conditions in working chamber after reaching equilibrium		
Type	Code	Test period(s)	Total	Air temperature	Relative humidity	
Constant-humidity condensation atmosphere		CH	From warm-up to end of exposure		Approx. 100 % with condensation on test specimens	
Alternating condensation atmosphere	With alternation of humidity and air temperature	AHT	8 h including warm-up	24 h	(40 ± 3) °C	
			16 h including cooling down (climatic chamber open or ventilated)		18 °C to 28 °C	Approaching ambient
	With alternation of air temperature	AT	8 h including warm-up	24 h	(40 ± 3) °C	Approx. 100 % with condensation on test specimens
			16 h including cooling down (climatic chamber closed)		18 °C to 28 °C	Approx. 100 % (≈ saturated)

NOTE Set points and operational fluctuations can either be listed independently of each other, or they can be listed in the format "set point ± operational fluctuations". The set point is the target condition for the sensor used at the operational control point as programmed by the user. Operational fluctuations are deviations from the set point at the control point as indicated by the readout of the calibrated control sensor during equilibrium operation and do not include measurement uncertainty. At the operational control point, the operational fluctuation may not exceed the listed value at equilibrium. When a standard calls for a particular set point, the user programmes that exact number. The operational fluctuations specified for the set point do not imply that the user is allowed to programme a set point higher or lower than the exact set point specified.

5 Apparatus

5.1 Climatic chamber

A vapour-tight climatic chamber is essential for testing in a warm and humid atmosphere. The material of the inner walls shall be corrosion-resistant and shall not affect the test specimens. The climatic chamber is usually

equipped with a floor trough which acts as the receptacle for the quantity of water prescribed in Subclause 6.1. The climatic chamber shall be controlled by heating the water in the floor trough.

If the quantity of heat introduced via the water is insufficient to raise the air temperature in the climatic chamber to the required level, then additional heating can be employed.

NOTE The heating-up time will depend on the nature and quantity of the test specimens, and also on the ratio of the surface of the water in the floor trough to the surface of the walls of the climatic chamber, and on the water temperature. The water temperature should preferably not exceed 60 °C in order to prevent excessive vapour formation.

The dimensions of the climatic chamber and the arrangement of its temperature-measuring and control equipment are optional, provided that the test conditions in accordance with Clause 4 and Subclause 6.3 are observed and that the temperature is measured.

The climatic chamber shall be provided with a suitable door or other aperture capable of being closed, which allows the climatic chamber to be charged with test specimens and to be ventilated.

An example of a climatic chamber is shown in Figure 1.

Climatic chambers not equipped with water-filled floor troughs shall be fitted out in such a way that adequate formation of condensation water on the test specimens is achieved.

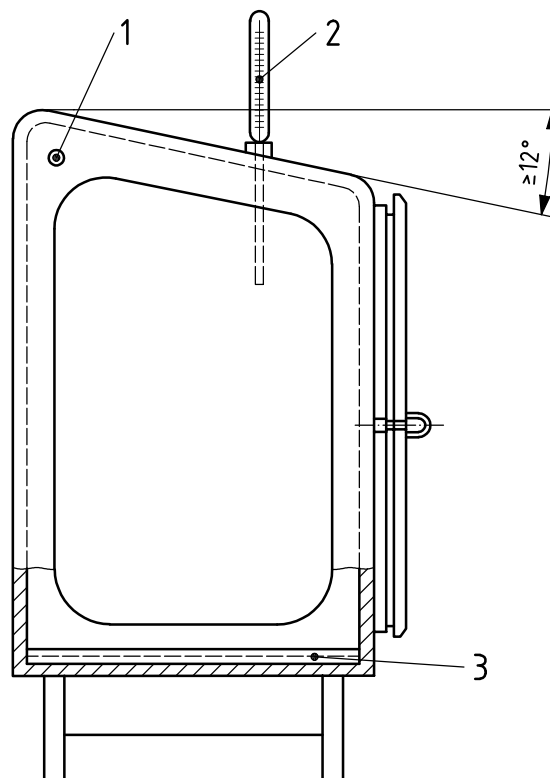

Key

- 1 pressure-relief valve
- 2 temperature-measuring device
- 3 floor trough filled with water

Figure 1 — Example of a climatic chamber

5.2 Installation of the climatic chamber

The climatic chamber shall be installed in a room with an ambient atmosphere containing no corrosive constituents (e.g. it shall not be installed in a chemical laboratory), at a room temperature of (23 ± 5) °C and at a relative atmospheric humidity of 75 % max., in such a way that it is protected against draughts and solar radiation. In the case of comparison tests, the ambient temperature in the installation room shall be the standard temperature of (23 ± 2) °C in accordance with ISO 3270.

NOTE A decrease in the ambient temperature will result in an increase in the quantity of condensation water.

5.3 Device for accommodating the test specimens

The device for accommodating the test specimens shall consist of a corrosion-resistant material and shall not promote the corrosion of the test specimens. It shall allow the test specimens to be arranged in accordance with the requirements of Subclause 6.3.

6 Procedure

6.1 Filling the floor trough

The floor trough shall be filled with water in such a way that a depth of water of at least 10 mm is present at all times during operation.

NOTE It is recommended that distilled or de-ionized water be used to avoid calcification of the apparatus.

6.2 Test specimens

Only coatings which do not mutually influence one another shall be exposed together at any one time.

6.3 Arrangement of the test specimens

The test specimens shall be arranged in the chamber at any angle greater than or equal to 60° to the horizontal in such a way that they are not in close contact with each other and that they are able adequately to radiate heat.

The following minimum spacing shall be observed:

Distance from the walls	not less than 100 mm
Distance of the bottom edge of the test specimen from the surface of the water	not less than 200 mm
Spacing between adjoining test specimens	not less than 20 mm

Precautions shall be taken to ensure that no condensation water is allowed to drip onto the test specimens from the walls or ceiling of the climatic chamber, nor from other test specimens.

6.4 Test sequence

6.4.1 Start-up

Place the test specimens in position, close the climatic chamber and switch on the heating for the floor trough water or for the climatic chamber. Heat the chamber to the air temperature required for the first test period; this temperature shall be attained within 1,5 h. Condensation water shall be formed on the test specimens.

6.4.2 Condensation atmosphere with constant humidity (CH)

Maintain the temperature prescribed in Clause 4 in the climatic chamber for the duration of the test as given in Table 1, or as mutually agreed.

In order to make an intermediate assessment, if necessary, remove the test specimens from the climatic chamber without switching off the heating, and replace them within 30 min.

6.4.3 Condensation atmosphere with alternation of humidity and air temperature (AHT)

The test consists of a prescribed or mutually agreed number of climatic cycles, each comprising a first and a second test period.

8 h after commencement of the start-up phase (see 6.4.1), switch off the heating and terminate the condensation process (first test period). Open or ventilate the climatic chamber.

After a further 16 h, check the level of the water in the floor trough, top up if necessary and close the climatic chamber. Switch on the heating again and commence a new cycle.

For the purposes of an intermediate assessment, if required, the test specimens may be removed briefly from the climatic chamber before the start of a new cycle, but shall be replaced within 30 min.

NOTE In special cases, intermediate assessments can also be carried out immediately after the heating has been switched off and the climatic chamber has been opened.

6.4.4 Condensation atmosphere with alternation of air temperature (AT)

The test consists of a prescribed or mutually agreed number of climatic cycles, each comprising a first and a second test period.

In the case of a 24 h cycle, switch off the heating 8 h after commencement of the start-up phase (see 6.4.1) and terminate the condensation process (first test period). The climatic chamber remains closed.

After a further 16 h have elapsed, check the level of the water in the floor trough, top up if necessary, and switch the heating on again to commence a new cycle.

In order to make an intermediate assessment, if required, briefly remove the test specimens from the climatic chamber before the start of a new cycle, but replace them within 30 min.

6.5 Interruptions

Any interruption of tests which involve alternating atmospheres shall be compensated for by a prolongation of the second test period, which normally lasts 16 h. The compensation time shall be added to the duration of the interrupted cycle in each case. The compensation time shall be recorded to the nearest minute in the test report.

6.6 End of test

Terminate the test when a specified impairment of the coating has occurred, or when the specified test duration or number of cycles has been attained.

7 Evaluation

Carry out the evaluation and record the results, including the number and timing of any intermediate assessments and the type of evaluation carried out at the final assessment of the test specimens, as required by the test standards concerned, or as otherwise agreed.

8 Test report

The test report shall contain at least the following information:

- a) all information necessary for identification of the product tested, including a description of the test specimens and their pretreatment if applicable;
- b) a reference to this part of ISO 6270 (ISO 6270-2:2005);
- c) the type of test atmosphere used (CH or AHT or AT), the cycle time and the duration of the test, and the reason for terminating the test;
- d) the number and timing of any intermediate assessments performed;
- e) details of handling of the test specimens between the end of the test and the beginning of the assessment;
- f) the results of the test, including the results for the individual test specimens and all the other information required by the test standards used, quoting the relevant standard in each case;
- g) any deviations from the procedure specified, including a full description of the climatic chamber if the test was carried out in equipment other than that specified in Clause 5;
- h) any unusual features (anomalies) observed during the test;
- i) the date of the test.

.....

ICS 87.040

Price based on 6 pages