

INTERNATIONAL  
STANDARD

ISO  
6246

Third edition  
2017-03

---

---

## Petroleum products — Gum content of fuels — Jet evaporation method

*Produits pétroliers — Teneur en gommes des carburants — Méthode  
d'évaporation au jet*



Reference number  
ISO 6246:2017(E)

© ISO 2017



**COPYRIGHT PROTECTED DOCUMENT**

© ISO 2017, Published in Switzerland

All rights reserved. Unless otherwise specified, no part of this publication may be reproduced or utilized otherwise in any form or by any means, electronic or mechanical, including photocopying, or posting on the internet or an intranet, without prior written permission. Permission can be requested from either ISO at the address below or ISO's member body in the country of the requester.

ISO copyright office  
Ch. de Blandonnet 8 • CP 401  
CH-1214 Vernier, Geneva, Switzerland  
Tel. +41 22 749 01 11  
Fax +41 22 749 09 47  
copyright@iso.org  
www.iso.org

# Contents

Page

Foreword .....	iv
Introduction .....	v
<b>1 Scope</b> .....	<b>1</b>
<b>2 Normative references</b> .....	<b>1</b>
<b>3 Terms and definitions</b> .....	<b>1</b>
<b>4 Principle</b> .....	<b>2</b>
<b>5 Reagents</b> .....	<b>2</b>
<b>6 Apparatus</b> .....	<b>2</b>
<b>7 Assembly of air-jet apparatus</b> .....	<b>3</b>
<b>8 Assembly of steam-jet apparatus</b> .....	<b>4</b>
<b>9 Calibration</b> .....	<b>5</b>
<b>10 Samples and sampling</b> .....	<b>5</b>
<b>11 Procedure</b> .....	<b>5</b>
<b>12 Calculation of gum content</b> .....	<b>7</b>
<b>13 Expression of results</b> .....	<b>8</b>
13.1 Aviation fuels .....	8
13.2 Non-aviation fuels .....	8
13.3 All fuel types .....	8
<b>14 Precision</b> .....	<b>8</b>
14.1 General .....	8
14.2 Repeatability, <i>r</i> .....	8
14.3 Reproducibility, <i>R</i> .....	9
<b>15 Test report</b> .....	<b>9</b>
<b>Bibliography</b> .....	<b>10</b>

## Foreword

ISO (the International Organization for Standardization) is a worldwide federation of national standards bodies (ISO member bodies). The work of preparing International Standards is normally carried out through ISO technical committees. Each member body interested in a subject for which a technical committee has been established has the right to be represented on that committee. International organizations, governmental and non-governmental, in liaison with ISO, also take part in the work. ISO collaborates closely with the International Electrotechnical Commission (IEC) on all matters of electrotechnical standardization.

The procedures used to develop this document and those intended for its further maintenance are described in the ISO/IEC Directives, Part 1. In particular the different approval criteria needed for the different types of ISO documents should be noted. This document was drafted in accordance with the editorial rules of the ISO/IEC Directives, Part 2 (see [www.iso.org/directives](http://www.iso.org/directives)).

Attention is drawn to the possibility that some of the elements of this document may be the subject of patent rights. ISO shall not be held responsible for identifying any or all such patent rights. Details of any patent rights identified during the development of the document will be in the Introduction and/or on the ISO list of patent declarations received (see [www.iso.org/patents](http://www.iso.org/patents)).

Any trade name used in this document is information given for the convenience of users and does not constitute an endorsement.

For an explanation on the voluntary nature of standards, the meaning of ISO specific terms and expressions related to conformity assessment, as well as information about ISO's adherence to the World Trade Organization (WTO) principles in the Technical Barriers to Trade (TBT) see the following URL: [www.iso.org/iso/foreword.html](http://www.iso.org/iso/foreword.html).

This document was prepared by ISO/TC 28, *Petroleum products and related products of synthetic or biological origin*.

This third edition cancels and replaces the second edition (ISO 6246:1995), which has been technically revised and aligned with ASTM D381<sup>[1]</sup>.

It also incorporates the Technical Corrigendum ISO 6246:1995/Cor 1:1998.

The changes incorporate modern methods for temperature measurement and clarification of various measurement limits. Some process steps on the rounding of results are added. The precision in the former edition was based on very old data using samples that did not contain components found in modern gasoline, such as oxygenated compounds and deposit control additives. New precision estimates from a 1997 joint ASTM/EI study<sup>[3]</sup> are included. Unwashed and washed gum results for non-aviation fuels can now be expressed to the nearest 0,5 mg/100 ml. This study and additional work in ASTM<sup>[4]</sup> and CEN in 2014<sup>[5]</sup> have led to broadening of the scope to modern gasoline (blends).

## Introduction

The true significance of this test method for determining gum in motor gasoline is not firmly established. It has been proven that high gum content can cause induction-system deposits and sticking of intake valves, and in most cases, it can be assumed that low gum content will ensure absence of induction-system difficulties. The user should, however, realize that the test is not of itself correlative to induction-system deposits.

The primary purpose of the test, as applied to motor gasoline, is the measurement of the oxidation products formed in the sample prior to or during the comparatively mild conditions of the test procedure. Since many kinds of motor gasoline are purposely blended with non-volatile oils or additives, the heptane extraction step is necessary to remove these from the evaporation residue so that the deleterious material, gum, can be determined. With respect to aviation turbine fuels, large quantities of gum are indicative of contamination of fuel by higher boiling oils or particulate matter and generally reflect poor handling practices in distribution downstream of the refinery.



# Petroleum products — Gum content of fuels — Jet evaporation method

**WARNING** — The use of this document can involve hazardous materials, operations and equipment. This document does not purport to address all of the safety problems associated with its use. It is the responsibility of users of this document to take appropriate measures to ensure the safety and health of personnel prior to application of the document, and fulfil statutory and regulatory requirements for this purpose.

## 1 Scope

This document specifies a method for determining the existent gum content of aviation fuels and the gum content of motor gasoline or other volatile distillates. It includes the determination of products containing ethanol (up to a volume fraction of 85 %) and ether-type oxygenates and deposit control additives.

For determination of gum content in automotive ethanol (E85) fuel, no precision data is available (see [14.1](#)).

For non-aviation fuels, a procedure for the determination of the heptane-insoluble portion of the residue is also described.

**CAUTION** — This method is not intended for the testing of gasoline components, particularly those with a high percentage of low-boiling unsaturated compounds, as they can cause explosions during evaporation.

## 2 Normative references

The following documents are referred to in the text in such a way that some or all of their content constitutes requirements of this document. For dated references, only the edition cited applies. For undated references, the latest edition of the referenced document (including any amendments) applies.

ISO 3170, *Petroleum liquids — Manual sampling*

ISO 3171, *Petroleum liquids — Automatic pipeline sampling*

ISO 3696, *Water for analytical laboratory use — Specification and test methods*

ISO 4259, *Petroleum products — Determination and application of precision data in relation to methods of test*

ISO 4788, *Laboratory glassware — Graduated measuring cylinders*

ASTM E2251-14, *Standard specification for liquid-in-glass ASTM thermometers with low-hazard precision liquids*

BS 2000, *IP standard thermometers*

## 3 Terms and definitions

For the purposes of this document, the following terms and definitions apply.

ISO and IEC maintain terminological databases for use in standardization at the following addresses:

— IEC Electropedia: available at <http://www.electropedia.org/>

— ISO Online browsing platform: available at <http://www.iso.org/obp>

- 3.1  
existent gum**  
*evaporation residue* (3.2) of aviation fuels without any further treatment
- 3.2  
evaporation residue**  
material that remains after controlled heating under a flow of air or steam
- 3.3  
unwashed gum content**  
(non-aviation fuel) *evaporation residue* (3.2) of the product under test without any further treatment
- 3.4  
solvent-washed gum content**  
(non-aviation fuel) residue remaining after the *evaporation residue* (3.2) has been washed with heptane and the washings discarded

## 4 Principle

A measured test portion of fuel is evaporated under controlled conditions of temperature and flow of air or steam. The resulting residue is weighed and may be subject to further treatment by solvent washing and further weighing.

## 5 Reagents

During the analysis, unless otherwise stated, use reagents of recognized analytical grade. Water, where specified, shall be of a quality equivalent to grade 3 of ISO 3696.

- 5.1 Heptane**,  $\text{CH}_3(\text{CH}_2)_5\text{CH}_3$ , of minimum 99,7 % purity.
- 5.2 Toluene**,  $\text{C}_6\text{H}_5\text{CH}_3$ .
- 5.3 Acetone**,  $\text{CH}_3\text{COCH}_3$ .
- 5.4 Gum solvent**, a mixture of equal volumes of toluene (5.2) and acetone (5.3).
- 5.5 Air supply**, filtered, at a gauge pressure of not greater than 35 kPa.
- 5.6 Steam supply**, free of oily residue and at a pressure of not less than 35 kPa.
- 5.7 Detergent cleaning solution.**

The type of detergent and conditions for its use shall be established in each laboratory. The criterion for satisfactory cleaning shall be a matching of the quality of that obtained with chromic acid cleaning solution on used beakers (fresh chromic acid, 6 h soaking period, rinsing with water and drying).

## 6 Apparatus

- 6.1 Balance**, capable of weighing to of the nearest 0,1 mg.



**6.2 Beakers**, capacity 100 ml, tall form, as illustrated in [Figure 1](#), individually permanently marked.

It is expedient to arrange the beakers in sets, the number in each set being the number of beaker wells in the evaporating bath. The lowest-mass beaker in each set should be reserved for use as the tare.

**6.3 Cooling vessel**, tightly covered vessel such as a desiccator without desiccant for cooling the beakers before weighing.

NOTE The use of a desiccant can lead to erroneous results.

**6.4 Evaporation bath**, either a solid metal block bath or a liquid bath, electrically heated and constructed in accordance with the general principles shown in [Figure 1](#), having wells and jets for two or more beakers.

The rate of air/steam flow at the temperature of test from each outlet jet when fitted with the conical adaptors with 500 µm to 600 µm copper or stainless steel screens shall be 1 000 ml/s ± 150 ml/s. A liquid bath, if used, shall be filled to within 25 mm of the top with a suitable liquid. Maintain the bath temperature either by means of thermostatic controls or by refluxing liquid of suitable composition.

**WARNING** — If a liquid-filled evaporation bath is used, care shall be taken to ensure that the flash point of the liquid used is at least 30 °C higher than the highest bath temperature expected.

**6.5 Flow indicator**, capable of indicating a total flow of air or steam equivalent to 1 000 ml/s for each outlet.

**6.6 Sintered glass filter funnel**, capacity 150 ml, with a maximum pore diameter between 150 µm and 250 µm.

**6.7 Steam super heater**, capable of delivering to the bath inlet the required amount of steam at 232 °C ± 3 °C.

**6.8 Temperature sensors**, liquid in glass thermometer conforming to the requirements in ASTM E2251-14 or IP 73C of BS 2000, or another temperature sensor or systems, or both, of at least equivalent accuracy and precision over a temperature range from -5 °C to 400 °C.

**6.9 Graduated cylinders**, capacity 50 ml or 100 ml and 2 l, conforming to the requirements of ISO 4788.

**6.10 Forceps**, stainless steel, spade-ended.

**6.11 Oven**, capable of being maintained at 150 °C ± 2 °C.

## 7 Assembly of air-jet apparatus

**7.1** Assemble the air-jet apparatus as shown in [Figure 1](#). With the apparatus at room temperature, adjust the flow of air to a rate of 600 ml/s at one of the outlets, with the remaining conical adaptors in position. Check the other outlets individually under the same conditions for uniform air flowrate within the range of 600 ml/s ± 90 ml/s.

NOTE A total reading on a flow indicator (calibrated under ambient conditions) corresponding to 600 ml/s ± 90 ml/s at each outlet will, in normal circumstances, ensure a flowrate of 1 000 ml/s ± 150 ml/s at a temperature of 155 °C ± 5 °C, provided that the back pressure across the flow indicator is not greater than 1 kPa.

**7.2** In order to set the apparatus in operation, heat the bath until the temperature reaches 160 °C to 165 °C, and then introduce air into the apparatus until the reading established in accordance with [7.1](#)

is obtained on the flow indicator. Measure the temperature in each well with the temperature sensors (6.8) placed with the thermometer bulb (or equivalent sensing device) resting on the bottom of a beaker (6.2) in the well. Do not use any well having a temperature that differs from 155 °C by more than 5 °C for standard tests.

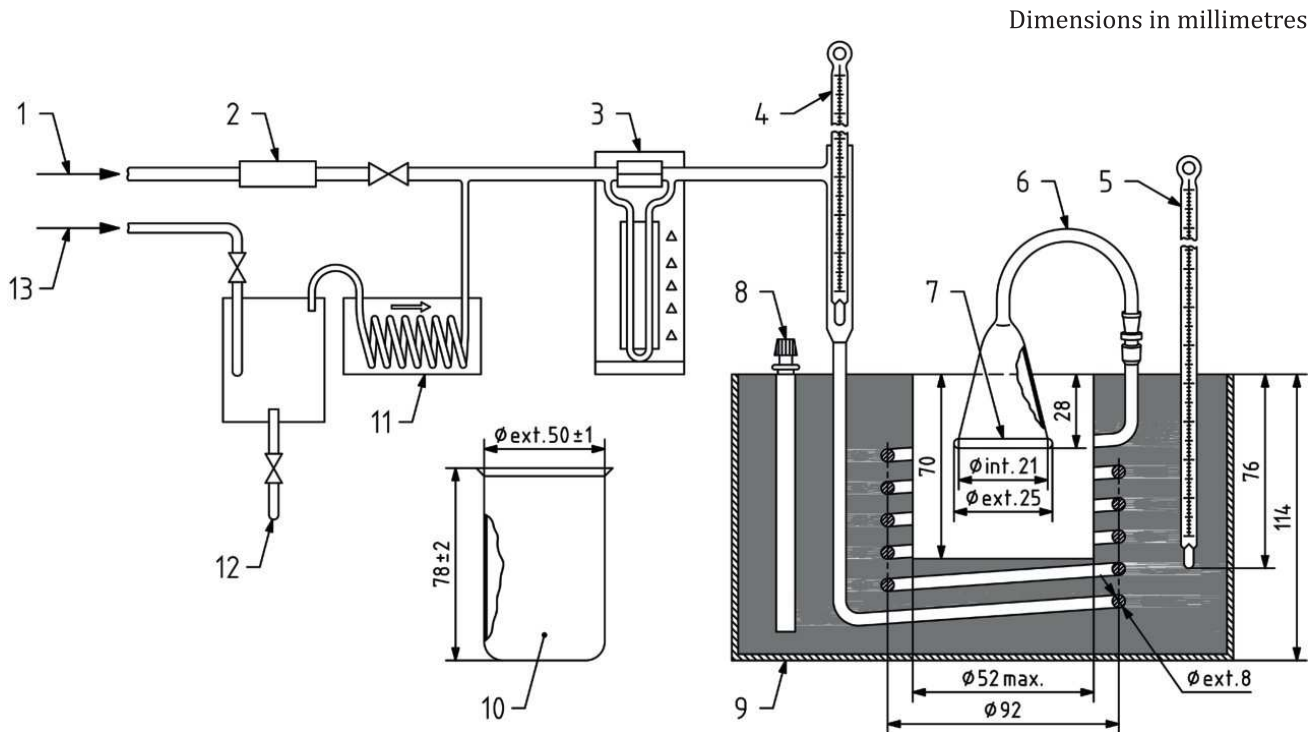

**Key**

- |   |  |    |                   |
|---|--|----|-------------------|
| 1 | air supply                                       | 8  | thermo-regulator  |
| 2 | cotton or glass wool filter                      | 9  | metal, black bath |
| 3 | flow indicator                                   | 10 | beaker            |
| 4 | thermometer and thermometer well (optional)      | 11 | super heater      |
| 5 | thermometer                                      | 12 | steam trap        |
| 6 | removable adaptor                                | 13 | steam supply      |
| 7 | copper or stainless steel screen, (500 - 600) μm |    |                   |

**Figure 1 — Apparatus for determining gum content by jet evaporation**

**8 Assembly of steam-jet apparatus**

8.1 Assemble the steam-jet apparatus as shown in [Figure 1](#).

**WARNING — The sample and solvent vapours evaporated during the performance of this test procedure can be extremely flammable or combustible and hazardous from the inhalation standpoint. To control such vapours and reduce the risk of thermal explosion and intoxication, national health and safety regulations are to be applied.**

8.2 In order to set the apparatus in operation, heat the bath until the temperature reaches 232 °C. Operate the super heater, and slowly admit dry steam into the apparatus until a flowrate of 1 000 ml/s ± 150 ml/s per outlet is obtained. Regulate the temperature of the bath within the range 239 °C ± 7 °C and that of the super heater to provide a well temperature of 232 °C ± 3 °C. Measure the temperature with the temperature sensor (6.8) placed with the thermometer bulb (or equivalent sensing

device) resting on the bottom of a beaker (6.2) in the well. Do not use any well having a temperature that differs from 232 °C by more than 3 °C for standard tests.

**8.3** Adjust the apparatus to give a steam flowrate of 1 000 ml/s for the outlet under test. Check the remaining outlets for uniform steam flow. Make necessary changes to individual outlets if the rate varies by more than 150 ml/s of steam, record the flowmeter reading and use this setting for subsequent testing.

## 9 Calibration

Calibrate the flowmeter by successively condensing the steam from each outlet and weighing the total quantity of water recovered. To accomplish this, attach a copper tube to a steam outlet jet and extend the tube into a 2 l cylinder (6.9) that has been filled with crushed ice and then weighed.

Exhaust the steam into the cylinder for approximately 60 s. Adjust the position of the cylinder so that the end of the copper tube is immersed in the water to a depth of less than 50 mm to prevent excessive back pressure.

Weigh the cylinder. The gain in mass represents the amount of steam condensed.

Calculate the steam flowrate,  $S$ , as given in [Formula \(1\)](#):

$$S = \frac{(m_{cs} - m_{ice}) \cdot 1\,000}{k \cdot t} \quad (1)$$

where

$S$  is the flowrate of the steam, in ml/s, at 232 °C;

$m_{cs}$  is the mass, in g, of the cylinder with the condensed steam;

$m_{ice}$  is the mass, in g, of the cylinder and ice;

$k$  is the mass (0,434 g) of 1 000 ml of steam at 232 °C at atmospheric pressure;

$t$  is the condensing time, in s.

## 10 Samples and sampling

Samples for testing by the procedures described in this document shall be taken by the procedure described in ISO 3170, ISO 3171 or in accordance with the requirements of national standards or regulations for the sampling of the product under test.

## 11 Procedure

**11.1** Wash the beakers (6.2) including the tare, with the gum solvent (5.4) until free of gum. Rinse thoroughly with water and immerse in detergent cleaning solution.

Remove the beakers from the cleaning solution by means of forceps (6.10) and handle only with forceps thereafter. Wash the beakers thoroughly, first with tap water and then with distilled water, and dry in the oven (6.11), controlled at 150 °C, for at least 1 h. Cool the beakers for at least 2 h in the cooling vessel (6.3) placed in the vicinity of the balance (6.1).

**NOTE** For the comparison of cleaning efficiency, visual appearance and loss in mass on heating the glassware under test conditions can be used. Detergent cleaning avoids the potential hazards and inconvenience related to handling corrosive chromic acid solution. The latter remains as the reference cleaning practice and as such can function as an alternative to the preferred procedure of cleaning with detergent solutions.

**WARNING — Chromic acid is a health hazard. It is toxic, a recognized carcinogen as it contains Cr(VI) compounds, is highly corrosive and potentially hazardous when in contact with organic materials. When using chromic acid cleaning solution, protective measures in accordance with national health and safety regulations, such as eye protection and protective clothing, are essential. Never pipette the cleaning solution by mouth. After use, do not pour cleaning solution down the drain, but neutralize it with great care owing to the concentrated sulfuric acid present, and dispose of it in accordance with standard procedures for toxic laboratory waste (chromium is highly dangerous to the environment).**

**Non-chromium-containing, strongly oxidizing acid cleaning solutions are also highly corrosive and potentially hazardous when in contact with organic materials, but do not contain chromium which has special disposal problems.**

**11.2** Select the required conditions for testing aviation and motor gasoline or aircraft turbine fuel from [Table 1](#) and set the apparatus in operation following the procedures of [7.2](#) or [8.2](#) as appropriate. If an external preheater is used, regulate the temperature of the (vaporizing) medium to give the specified test well temperature.

**Table 1 — Test conditions**

Sample type	Vaporizing medium	Operating temperature °C	
		Bath	Test well
Aviation and motor gasoline	Air	160 to 165	150 to 160
Aircraft turbine fuel	Steam	232 to 246	229 to 235

**11.3** Weigh the test beakers against the tare beaker to the nearest 0,1 mg. When a single-pan balance is used, weigh the tare beaker as a blank. Record the mass of each beaker.

**11.4** If suspended or settled solid matter is present, mix the contents of the sample container thoroughly. Immediately filter a quantity of the sample, at atmospheric pressure, through the sintered glass funnel ([6.6](#)). Treat the filtrate as specified in [11.5](#) to [11.7](#) inclusive.

**11.5** By means of the graduated cylinders ([6.9](#)), add 50 ml ± 0,5 ml of the sample to each beaker except the tare, using one beaker for each of the fuels to be tested.

Place the filled beakers, and the tare in the evaporation bath ([6.4](#)). The elapsed time between placing the first and last beakers in the bath shall be as short as possible. When evaporating samples by means of air, replace the conical adaptor as each individual beaker is placed in the bath. When using steam, allow the beakers to heat for 3 min to 4 min before replacing the conical adaptor, which shall be preheated in the steam stream prior to attaching to the outlet. Centre the conical adaptors above the centre of the liquid surface. Take care to avoid splashing when introducing the jet of air or vapour, as this could cause gum values to be in error.

Maintain the temperature and rate of flow and allow the test portions to evaporate for 30 min ± 0,5 min. Samples tested simultaneously shall have similar evaporation characteristics.

NOTE In certain cases, duplicate testing is advisable to check if the test method’s repeatability is met.

**11.6** At the end of the heating period, transfer the beakers from the bath to the cooling vessel ([6.3](#)). Place the cooling vessel in the vicinity of the balance for at least 2 h. Weigh the beakers in accordance with [11.3](#). Record the mass of the beakers.

**11.7** Segregate beakers containing residues from products for which the heptane-insoluble portion of the gum is also required to be determined, and follow [11.8](#) to [11.12](#). The remaining beakers may be returned for cleaning and reuse.

**11.8** For non-aviation fuels that have unwashed results that are <0,5 mg/100 ml, it is not necessary to perform the washing steps identified in this clause, as well as in those that follow since the washed gum value will always be smaller than or equal to the unwashed gum value. If the unwashed results are not <0,5 mg/100 ml, add 25 ml of heptane to each of the beakers segregated in [11.7](#), together with the tare beaker, and swirl gently for 30 s. Allow the mixture to stand for 10 min ± 1 min.

**11.9** Decant and discard the heptane solution, taking care to prevent the loss of any solid residue.

**11.10** Repeat the extraction with a second 25 ml portion of the heptane, as described in [11.8](#) and [11.9](#). Repeat the extraction a third time if the extract is coloured.

**11.11** Place the beakers, including the tare, in the evaporation bath, maintained at 160 °C to 165 °C and, without replacing the conical adaptors, allow the beakers to dry for 5 min ± 0,5 min.

**11.12** At the end of the drying period, remove the beakers from the bath, place them in the cooling vessel ([6.3](#)) and allow them to cool in the vicinity of the balance for at least 2 h. Weigh and record the mass of the beakers.

## 12 Calculation of gum content

**12.1** Calculate the gum content,  $A$ , using [Formula \(2\)](#):

$$A = 2\,000 \left[ (m_1 - m_3) - (m_2 - m_4) \right] \quad (2)$$

where

- $A$  is the gum content, expressed as mg per 100 ml;
- $m_1$  is the mass, in g, of the sample beaker plus residue;
- $m_2$  is the mass, in g, of the tare beaker after treatment;
- $m_3$  is the mass, in g, of the empty sample beaker;
- $m_4$  is the mass, in g, of the tare beaker before treatment.

**12.2** If a double-pan balance is used, with the weighings made against the tare before and after treatment, use [Formula \(3\)](#):

$$A = 2\,000 (m_5 - m_6) \quad (3)$$

where

- $m_5 = m_1 - m_2$ , in g;
- $m_6 = m_3 - m_4$ , in g.



## 13 Expression of results

### 13.1 Aviation fuels

For aviation fuels with gum contents  $\geq 1$  mg/100 ml, express the results, to the nearest 1 mg/100 ml, as existent gum. Round figures in accordance with ISO 4259 practices (see also ASTM E29[2] or Appendix E of Reference [6]).

For results  $< 1$  mg/100 ml, report as " $< 1$  mg/100 ml".

### 13.2 Non-aviation fuels

For non-aviation fuels with either solvent-washed or unwashed gum contents  $\geq 0,5$  mg/100 ml, express the results, to the nearest 0,5 mg/100 ml as either solvent-washed gum or unwashed gum content, or both. Round figures in accordance with ISO 4259 practices (see also ASTM E29[2] or Appendix E of Reference [6]).

For results  $< 0,5$  mg/100 ml, report as " $< 0,5$  mg/100 ml." If the unwashed gum content is  $< 0,5$  mg/100 ml, the washed gum may also be reported as " $< 0,5$  mg/100 ml" (see 11.8).

### 13.3 All fuel types

If the filtration step (11.4) has been carried out before the evaporation, the word "filtered" shall follow the numerical value.

## 14 Precision

### 14.1 General

The precision, as obtained by statistical examination of interlaboratory test results, is given in 14.1 and 14.2. Precision estimates for gum content originate from a 1997 joint ASTM/EI study[3] using gasoline samples containing oxygenates at a volume fraction of 0 % to 15 % and deposit control additive at 0 mg/l to 80 mg/l.

The precision values given for solvent-washed and unwashed gum content were obtained on fourteen finished gasoline fuels, which included two samples containing a volume fraction of 10 % ethanol and five samples containing a volume fraction of 15 % methyl tertiary butyl ether (MTBE), as well as deposit control additives as determined in a 1997 interlaboratory study. The precision values for the solvent-washed and unwashed gum content are based on samples containing between (0 to 15) mg/100 ml and (0 to 50) mg/100 ml gum content, respectively[4]. Work in CEN[5] did not give indications that gasoline containing up to a volume fraction of 85 % ethanol would show different precision.

### 14.2 Repeatability, $r$

The difference between successive test results obtained by the same operator with the same apparatus under constant operating conditions on identical test material would, in the normal and correct operation of the test method, exceed the value below only in one case in 20:

$$r = 1,11 + 0,095 X, \text{ for existent gum (aviation gasoline);}$$

$$r = 0,588 2 + 0,249 X, \text{ for existent gum (aviation turbine fuel);}$$

$$r = 0,997 X^{0,4}, \text{ for gum content (unwashed);}$$

$$r = 1,298 X^{0,3}, \text{ for gum content (solvent washed);}$$

where

$X$  is the average of the results being compared.

### 14.3 Reproducibility, $R$

The difference between two test results independently obtained by different operators operating in different laboratories on nominally identical test material would, in the normal and correct operation of the test method, exceed the value below only in one case in 20:

$R = 2,09 + 0,126 X$ , for existent gum (aviation gasoline);

$R = 2,941 + 0,279 4 X$ , for existent gum (aviation turbine fuel);

$R = 1,928 X^{0,4}$ , for gum content (unwashed);

$R = 2,494 X^{0,3}$  for gum content (solvent washed);

where

$X$  is the average of the results being compared.

## 15 Test report

The test report shall contain at least the following information:

- a) a reference to this document, i.e. ISO 6246;
- b) the type and complete identification of the product tested;
- c) the result of the test (see [Clause 13](#));
- d) any deviation by agreement or otherwise from the procedure specified;
- e) the date of the test.

## Bibliography

- [1] ASTM D381-12, *Standard test method for gum content in fuels by jet evaporation*
- [2] ASTM E29, *Standard practice for using significant digits in test data to determine conformance with specifications*
- [3] IP Precision Evaluation Panel Report, June 18, 1998, Energy Institute, 61 New Cavendish Street, London W1G 7AR, United Kingdom
- [4] Research report RR: D02-1466, An interlaboratory study for test method D381 to establish a precision statement that is applicable to modern gasoline's which contain can contain oxygenated compounds and are required to contain deposit control additives, June 2007, ASTM International, 00 Barr Harbor Drive, PO Box C700, West Conshohocken, PA 19428-2959, USA
- [5] E85 test method assessment, October 2014, CEN/TC 19 RRT report number 2013-002, available from CEN/TC 19 Secretariat, NEN, the Netherlands, [energy@nen.nl](mailto:energy@nen.nl),
- [6] IP Standard Methods for Analysis and Testing of Petroleum and Related Products, Energy Institute, 61 New Cavendish Street, London W1G 7AR, United Kingdom





