**Micrographics — Microfilming of
documents on 16 mm and 35 mm silver-
gelatin type microfilm — Operating
procedures**

*Micrographie — Microfilmage des documents sur microfilms gélatino-
argentiques de 16 mm et 35 mm — Modes opératoires*



PDF disclaimer

This PDF file may contain embedded typefaces. In accordance with Adobe's licensing policy, this file may be printed or viewed but shall not be edited unless the typefaces which are embedded are licensed to and installed on the computer performing the editing. In downloading this file, parties accept therein the responsibility of not infringing Adobe's licensing policy. The ISO Central Secretariat accepts no liability in this area.

Adobe is a trademark of Adobe Systems Incorporated.

Details of the software products used to create this PDF file can be found in the General Info relative to the file; the PDF-creation parameters were optimized for printing. Every care has been taken to ensure that the file is suitable for use by ISO member bodies. In the unlikely event that a problem relating to it is found, please inform the Central Secretariat at the address given below.

© ISO 2005

All rights reserved. Unless otherwise specified, no part of this publication may be reproduced or utilized in any form or by any means, electronic or mechanical, including photocopying and microfilm, without permission in writing from either ISO at the address below or ISO's member body in the country of the requester.

ISO copyright office
Case postale 56 • CH-1211 Geneva 20
Tel. + 41 22 749 01 11
Fax + 41 22 749 09 47
E-mail copyright@iso.org
Web www.iso.org

Published in Switzerland

Contents

Page

Foreword.....	iv
1 Scope	1
2 Normative references	1
3 Terms and definitions	2
4 Preparation of documents	2
5 Conditions of microfilming	2
5.1 Raw-stock microfilm	2
5.2 Formats and orientation	2
5.3 Roll film coding	5
5.4 Frame numbering	5
5.5 Placement	5
5.6 Inter-image gap	5
5.7 Edge marker	5
5.8 Reduction ratio	5
5.9 Document dimensions	6
6 Microfilming procedures	9
6.1 Documents recorded on more than one roll of film	9
6.2 Leader and trailer	9
7 Filming sequence	9
7.1 Targets	9
7.2 Archival test area	10
7.3 Retakes	10
7.4 Targets	10
8 Scanning microfilm	12
8.1 Cameras used for producing scanning microfilm	12
8.2 Frame numbering	12
8.3 Placement	12
8.4 Edge detection	12
8.5 Targets	12
8.6 Image density	13
8.7 Skew	13
8.8 Resolution	13
9 Splices	13
10 Document placement on the camera baseboard	13
11 Winding	13
12 Quality control	14
13 Legal Admissibility	14
Annex A (informative) Preparation of documents	15
Annex B (informative) Resolution	17
Bibliography	19

Foreword

ISO (the International Organization for Standardization) is a worldwide federation of national standards bodies (ISO member bodies). The work of preparing International Standards is normally carried out through ISO technical committees. Each member body interested in a subject for which a technical committee has been established has the right to be represented on that committee. International organizations, governmental and non-governmental, in liaison with ISO, also take part in the work. ISO collaborates closely with the International Electrotechnical Commission (IEC) on all matters of electrotechnical standardization.

International Standards are drafted in accordance with the rules given in the ISO/IEC Directives, Part 2.

The main task of technical committees is to prepare International Standards. Draft International Standards adopted by the technical committees are circulated to the member bodies for voting. Publication as an International Standard requires approval by at least 75 % of the member bodies casting a vote.

Attention is drawn to the possibility that some of the elements of this document may be the subject of patent rights. ISO shall not be held responsible for identifying any or all such patent rights.

ISO 6199 was prepared by Technical Committee ISO/TC 171, *Document management applications*, Subcommittee SC 2, *Application issues*.

This second edition cancels and replaces the first edition (ISO 6199:1991), which has been technically revised.

Micrographics — Microfilming of documents on 16 mm and 35 mm silver-gelatin type microfilm — Operating procedures

1 Scope

This International Standard specifies procedures that enable a camera operator to produce microfilm of appropriate quality of presentation and legibility, capable of yielding scanned images of acceptable quality.

This International Standard specifies methods for microfilming documents on 16 mm and 35 mm silver-gelatin microfilm, including orientation of images on microfilm, use of non-image areas and information required to facilitate identification of the microfilm.

This International Standard applies to microfilming using rotary and planetary cameras.

This International Standard does not apply to the filming of technical drawings, maps and plans and newspapers, for which specific International Standards exist [1-3].

2 Normative references

The following referenced documents are indispensable for the application of this document. For dated references, only the edition cited applies. For undated references, the latest edition of the referenced document (including any amendments) applies.

ISO 3334:—¹⁾, *Micrographics — ISO resolution test chart No. 2 — Description and use*

ISO 6148:2001, *Photography — Micrographic films, spools and cores — Dimensions*

ISO 6196 (parts 1 to 8 and 10), *Micrographics — Vocabulary*

ISO 6200:1999, *Micrographics — First generation silver-gelatin microforms of source documents — Density specifications and method of measurement*

ISO 9878:1990, *Micrographics — Graphical symbols for use in microfilming*

ISO/TR 10200:1990, *Legal admissibility of microforms*

ISO 10550:1994, *Micrographics — Planetary camera systems — Test target for checking performance*

ISO 10594, *Micrographics — Rotary camera systems — Test target for checking performance*

ISO 11962:2002, *Micrographics — Image mark (blip) used with 16 mm and 35 mm roll microfilm*

ISO 18906:2000, *Imaging materials — Photographic films — Specifications for safety film*

1) To be published. (Revision of ISO 3334:1989)

3 Terms and definitions

For the purposes of this document, the terms and definitions given in ISO 6196 and the following apply.

3.1 inter-image gap
inter-frame gap
 distance, measured along the long edge of a roll microfilm, between the trailing edge of one microimage and the leading edge of the following microimage

3.2 scanning microfilm
 microfilm intended to be used for scanner input

4 Preparation of documents

Documents to be microfilmed shall be examined carefully, defects remedied where appropriate, foreign bodies (e.g. fasteners) removed and pages arranged in the required order.

Documents to be microfilmed shall be examined to ensure that their dimensions are within those acceptable to the microfilming system.

Appropriate targets shall be added to each batch of documents during the preparation stage.

Annex A gives more details on the preparation of documents prior to microfilming.

5 Conditions of microfilming

5.1 Raw-stock microfilm

Raw-stock microfilm shall comply with the requirements of ISO 6148 and ISO 18906.

5.2 Formats and orientation

5.2.1 Formats

The formats commonly used in roll microfilm are shown in Figure 1.

The dimensions for the placement of the microimages on the film are listed in Table 1.

Table 1 — Dimensions of frames for unperforated film without document marks
 (see Figure 1)

Values in millimetres

Dimension	Measure	16 mm film	35 mm film
<i>a</i> max.	image width	14,92	33,00 ^a
<i>c</i> min.	inter-image gap	1,00	2,00
<i>d</i> min.	side margin	0,50	0,97
<i>e</i> min.	side margin	0,50	0,97
<i>f</i> min. ^b	centre margin	0,50	0,97
NOTE Film width (e.g. $a + 2d$) shall be in accordance with ISO 6148. Image areas are smaller.			
^a For some applications, this figure may change in accordance with the relevant International Standard.			
^b For all formats except simplex.			

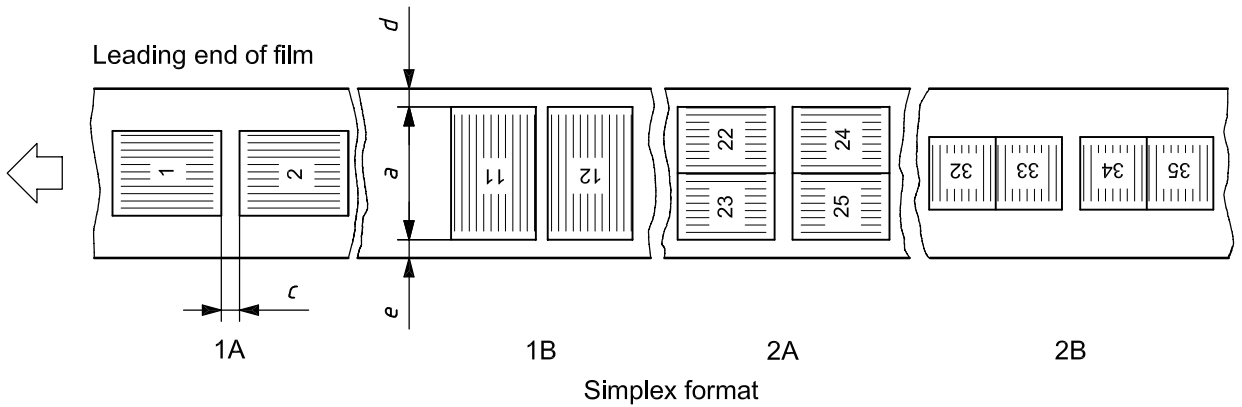
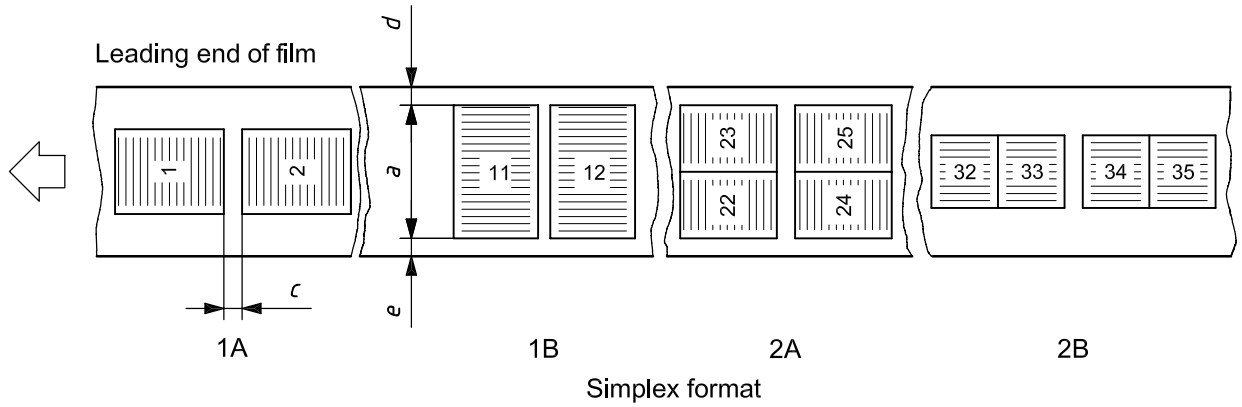

Alternate orientation for documents with right to left scripts

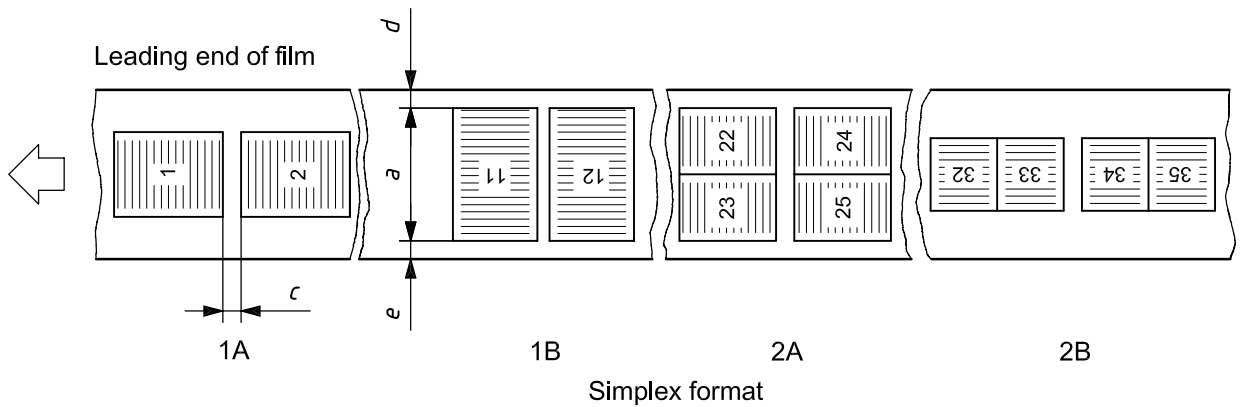

Preferred orientation for documents with horizontal and right to left scripts

Figure 1 — Roll microfilm formats

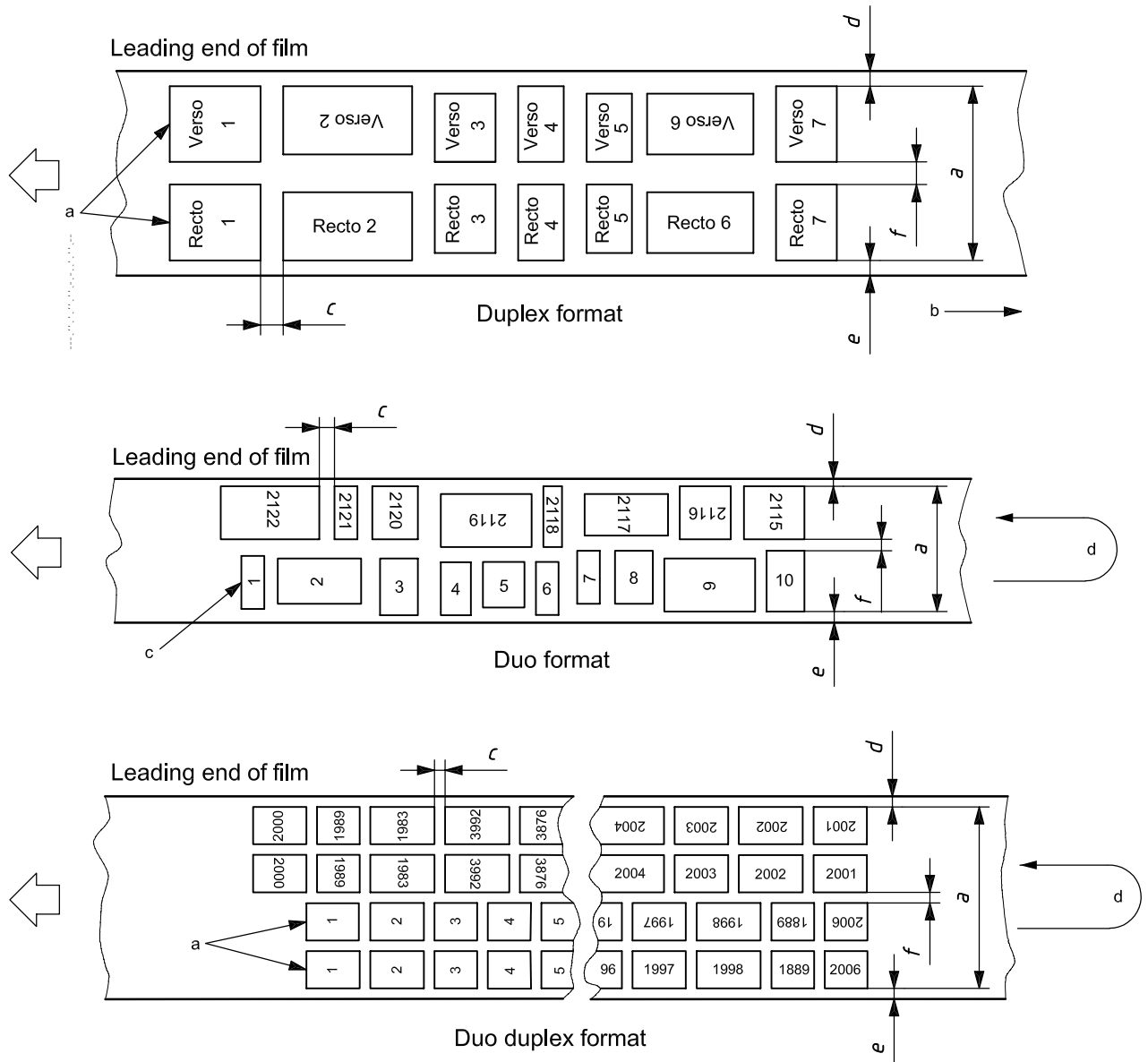

NOTE 1 On the duplex format, the image orientation of one row (front) is controlled by the orientation of the text on the original page, and the image orientation of the opposite row (back) is controlled by the image orientation of the above mentioned row.

NOTE 2 The duo duplex format is used primarily in banking applications.

- a Front and back of first document
- b Ascending order
- c First (or last) document
- d Ascending (or descending) order

Figure 1 (continued)

5.2.2 Orientation

Where microimages are recorded in simplex format, horizontal mode (comic), orientations 1B and 2B of Figure 1 shall be used. Where simplex format, vertical mode (cine) is used, the microimages should be oriented as shown in 1A and 2A of Figure 1.

The orientation of microimages for filming in duplex, duo and combination duo-duplex formats is also shown in Figure 1.

5.3 Roll film coding

Microimages may be coded so that individual microimages or series of microimages can be easily located. Examples of coding systems are specified in ISO 11962.

5.4 Frame numbering

Where frame numbers are used, they shall not appear within the microimage frame area. They may appear towards either edge of the microfilm, or within the inter-image gap, offset towards the top or bottom of the gap. Frame numbers shall not exceed 2 mm in height, measured on the microfilm.

The positioning of the frame numbers shall remain consistent within a roll of microfilm.

See also 8.2.

5.5 Placement

Microimages shall be centrally placed across the width of the frame area, with at least 30 % of each microimage in each half of the useable width of the microfilm.

See also 8.3.

5.6 Inter-image gap

The inter-image gap shall be as specified in Table 1.

NOTE When using scanning microfilm, this inter-image gap is crucial to the detection of the image edge (see 8.4).

5.7 Edge marker

This subclause applies to microfilming using planetary cameras only.

Where the leading edge of a document to be microfilmed is so irregular that there is no segment of this edge that can be said to define the position of the edge unambiguously, a matt white bar of minimum width 3 mm shall be placed on the camera baseboard, parallel to the leading edge of the microimage area, and just touching the leading edge of the document. The length of the bar shall be sufficient to extend across the whole width of the microimage area.

5.8 Reduction ratio

The reduction ratio and orientation selected should allow the smallest alphanumeric characters to be legible in a distribution copy projected on a reader screen and on a hard copy made from a distribution copy.

The reduction ratio to be used shall be determined by the size of the characters, the quality of the originals, the quality of the camera-film system, and the size of the documents to be microfilmed. Where possible, horizontal mode should be used.

5.9 Document dimensions

5.9.1 General

The maximum height or width of a microimage that can be recorded on the usable width of the film is indicated in Table 1 and Figure 1 for uncoded film and Figure 2 for coded film.

NOTE The maximum height or width of the document depends on the film format, the reduction ratio and the type of camera (rotary or planetary) to be used.

5.9.2 Simplex format using rotary cameras

The side of a microimage which is parallel to the length of the film may be of any length.

Table 2 lists two of the most commonly used reduction ratios for the simplex format of uncoded film from 16 mm rotary cameras. If a microimage is close to the indicated recordable size, a higher reduction ratio shall be used to reduce the possibility of information loss caused by skewing of the document while it is being filmed.

NOTE The maximum dimensions of a document that can be filmed are determined by the width of the throat of the document feeder.

Table 2 — 16 mm rotary microfilm camera — Simplex format for uncoded film

Values in millimetres

Nominal reduction ratio	Maximum dimension of document side perpendicular to the long axis of the film
1:20	298
1:24	357

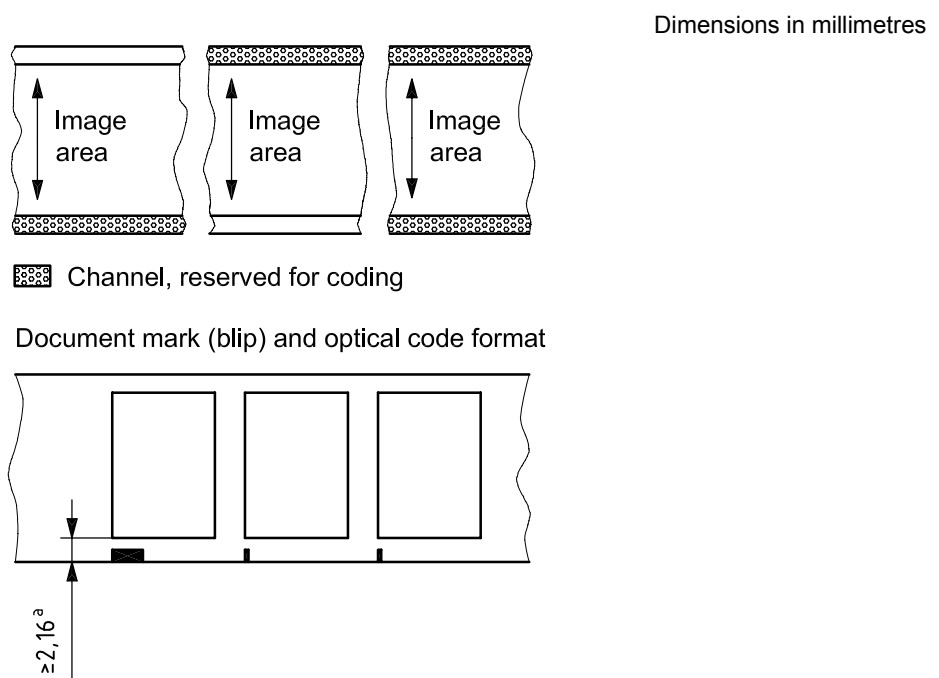

^a Channel reserved for document mark.

Figure 2 — Channels provided for document marks (blips) and optical code format

5.9.3 Simplex format using planetary cameras

Simplex format is also used with planetary cameras that can have variable (or a set of fixed) reductions and a variable frame pitch. Table 3 lists the maximum dimensions of documents usable with various reduction ratios. For microfilming using fixed frame-pitch cameras, see Table 4 and Figure 3.

NOTE To allow for positioning errors, the actual dimensions of the documents should be less than those indicated.

For 35 mm film intended for insertion in A6 jackets as strips of three frames, the maximum frame pitch shall be 47,5 mm. Appropriate reduction ratio changes may be required to accommodate the shorter frame advance.

**Table 3 — Planetary roll microfilm camera with adjustable frame pitch —
Maximum dimensions of documents**

Values in millimetres

Reduction ratio ^a	Maximum dimensions of documents			
	16 mm microfilm		35 mm microfilm	
	Length	Width	Length	Width
1:6	229	90	267	190
1:8	305	120	356	254
1:10	381	150	444	318
1:12	457	180	533	381
1:14	533	210	622	444
1:15	572	225	667	476
1:16	610	240	711	508
1:18	686	270	800	572
1:20	762	300	889	635
1:21	800	315	933	667
1:22	838	330	978	698
1:24	914	360	1 067	762
1:26	991	390	1 156	826
1:27	1 029	405	1 200	857
1:28	1 067	420	1 245	889
1:29	1 105	435	1 289	921
1:30	1 143	450	1 334	952
1:32	1 219	480	1 422	1 016
1:34	1 295	510	1 511	1 080
1:36	1 372	540	1 600	1 143

^a Caution, actual reduction ratios used in practice may be different to those indicated in this table. Relevant measurements can be calculated by applying the reduction ratio to the image frame dimensions.

Table 4 — Planetary roll film camera with fixed film advance
(see Figure 3)

Values in millimetres

35 mm microfilm	Dimensions
Frame ($a \times b$)	$33_{-0,5}^0 \times 45_{-0,5}^0$
Frame pitch (t)	$52_{-1,2}^0$

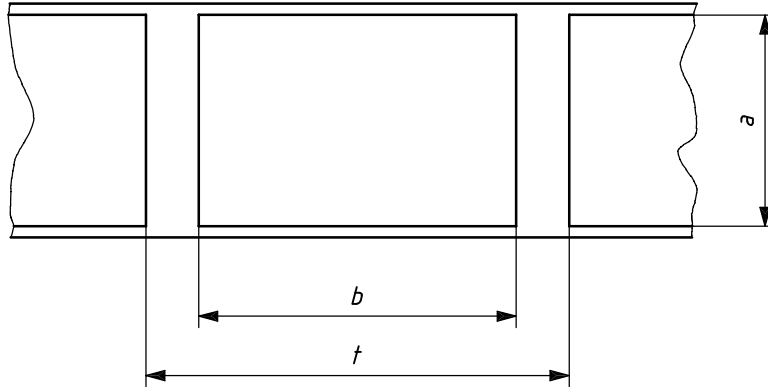

Figure 3 — Frame and frame pitch

5.9.4 Simplex format coding

Simplex format is also used with microfilm that is coded along the edge with a document mark or a photo-optical code. Coded microfilm is produced in both planetary and rotary cameras at a fixed reduction ratio. The manufacturer of the camera will provide the maximum dimensions for documents that can be microfilmed with the camera. To allow for positioning errors, the dimensions of the documents shall be less than those indicated.

5.9.5 Duplex, duo and duo duplex formats using rotary cameras

Duplex, duo and duo duplex formats are achieved only by using rotary cameras.

Table 5 lists the maximum dimensions of a document that may be microfilmed, for the most commonly used reduction ratios for the duplex, duo and duo duplex formats. To allow for errors in positioning and transporting the documents, the dimensions shall be less than the maximum allowed.

Table 5 — 16 mm rotary microfilm camera duplex, duo and duo duplex formats on uncoded film

Values in millimetres

Reduction ratio	Maximum height or width of documents
1:32	230
1:40	288
1:45	324
1:50	360

6 Microfilming procedures

6.1 Documents recorded on more than one roll of film

If a sequence of documents requires multiple rolls, the order and continuity of the documents shall be maintained on the microfilm.

6.2 Leader and trailer

In addition to any fogged microfilm, which may be removed, each roll of exposed microfilm shall have at the beginning and at the end a length of unexposed microfilm. This length shall be at least 700 mm for 16 mm microfilm and $(500 + {}^{200}_0)$ mm for 35 mm microfilm.

NOTE This leader and trailer is used to accommodate automatic threading readers.

Where the intended retrieval device is known, the specifications for leader and trailer requirements shall be complied with.

7 Filming sequence

7.1 Targets

Any targets required shall be microfilmed in the order indicated in Table 6.

Table 6 — Filming sequence

Sequence	Target	Subclause
1	Clear leader for archival test	7.2
2	Leader for threading	6.2
3	Beginning-of-roll target	7.4.2
4	Beginning continuation target	7.4.3
5	Retake targets as applicable	7.3
6	Roll number target	7.4.4
7	Title target	7.4.5
8	Special targets as applicable	7.4.6
9	Test target	7.4.7
10	Documents (insert miscellaneous targets as appropriate)	7.4.8
11	Document count target	7.4.9
12	Ending continuation target	7.4.10
13	End-of-roll target	7.4.11
14	Trailer for threading	6.2
15	Clear trailer for archival test	7.2

7.2 Archival test area

If archival tests are required, at least 300 mm of 16 mm or 35 mm microfilm with minimum density (clear) shall be left at the beginning and end of each roll in addition to the leader and trailer.

7.3 Retakes

The following sequence should be used when microfilming retakes:

- a) Target stating 'retakes for roll No. ...';
- b) Test target as described in 7.4.7;
- c) Special targets if applicable;
- d) Retake documents to be microfilmed;
- e) Target stating 'end of retakes for roll No. ...'.

A clear area may be added after retakes, to allow for splicing or other requirements.

7.4 Targets

7.4.1 General

Requirements for targets vary depending upon the application requirements. Some may be considered essential, and others optional.

7.4.2 Beginning-of-roll target

The beginning-of-roll target shall contain either the symbol described in ISO 9878 or the word "START".

7.4.3 Beginning continuation target

Where a continuous sequence of documents is recorded on more than one roll of microfilm, a beginning continuation target shall be used, which shall contain the words "Continued from roll number ...".

7.4.4 Roll number target

The roll number target shall indicate the roll number. The numerals shall be large enough to appear at least 2 mm high in the microimage.

7.4.5 Title target

The title target shall contain:

- a description of the documents on the microfilm;
- the name of the camera operator;
- the name of the publisher (where appropriate);
- the name and location of microfilming company (where appropriate);
- the date of microfilming.

7.4.6 Optional special targets

7.4.6.1 General

One or more special targets, such as targets for operator certificates, can be used for special purposes.

7.4.6.2 Restriction or classification target

The restriction or classification target shall contain any restrictions on access or use, including further reproduction or security classification.

7.4.6.3 Information sheet

The information sheet shall list the microfilming and quality requirements and the relevant microfilm system specifications.

7.4.6.4 Bibliographic target

The bibliographic target shall contain the editorial bibliographic data for the documents microfilmed and shall indicate the storage location of the original documents.

7.4.7 Test target

A test target shall appear on each roll of microfilm in the position shown in Table 6 and where any change of reduction ratio occurs on that roll.

The size of the target shall be such that its microimage shall occupy the full width of the microimage area, at the selected reduction ratio.

For planetary microfilming, a test target in accordance with ISO 10550 shall be used.

For rotary microfilming, a test target in accordance with ISO 10594 shall be used.

7.4.8 Documents and associated targets

Documents shall be microfilmed in the position shown in Table 6, with ISO symbols inserted as needed. If the ISO symbols are not sufficient, targets with appropriate explanations may be microfilmed.

7.4.9 Document count target

The document count target shall state the total number of documents on the roll of microfilm, including all targets.

7.4.10 Ending continuation target

Where a continuous sequence of documents is recorded on more than one roll of microfilm, an ending continuation target shall be used, which shall specify the identification of the next roll by a target worded "Continued on roll number ...".

7.4.11 End-of-roll target

The end-of-roll target shall contain either the symbol described in ISO 9878 or the word "END".

8 Scanning microfilm

8.1 Cameras used for producing scanning microfilm

Where planetary cameras are used, their baseboard shall be matt black.

This allows the microimage of the document to be clearly distinguishable from that of the baseboard and ensures that any visible part of the baseboard within the microimage area is indistinguishable from the inter-frame gap or the top or bottom edges of the microfilm. A white background the size of the documents being scanned can be used and a black edged piece on the copy board helps to produce a “sharp” leading edge.

Where rotary cameras are used in producing scanning microfilm, care shall be taken to minimize skew angles.

The possibilities of high skew angles caused by the production of a microimage of overlapped documents due to misfeeds are unacceptable. Such situations may result in the absence of inter-image gaps, which are essential for edge detection when scanning.

8.2 Frame numbering

Although it can be useful during the quality control of scanned images in facilitating the location of corresponding microimages, frame numbering is not necessary for scanning microfilm. If used, frame numbers shall be positioned such that they do not interfere with effective frame detection during scanning. Frame numbers shall either be kept out of the frame area (i.e. the area to be scanned), or shall be placed to avoid conflict with edge detection mechanisms.

Where frame numbering is used, the numbers shall be recorded (at the filming stage) above each frame. The number size shall be sufficiently high on the camera baseboard to enable compliance with 5.4. The numbers or the background (depending upon polarity) should have (on the microfilm) a density of at least 1,2 and should be clear and sharp. The numbers shall appear as the same polarity as the microimages. The frame numbers may be preceded by the words “FRAME NUMBER” in bold letters on the microfilm.

NOTE If frame numbering is used and small documents are being microfilmed, there is a risk that even with “correct” placement of the frame number, there could still be a problem with edge detection unless blipped microfilm is used.

8.3 Placement

Microimages shall be placed as specified in 5.5.

8.4 Edge detection

For documents having ragged edges, an edge marker as specified in 5.7 shall be used.

8.5 Targets

8.5.1 Test target

Test targets (see 7.4.7) for scanning microfilm shall additionally contain pairs of dimensioned lines (such as lines 100 mm long) at right angles, to enable scanned images to be independantly scaled in the x and y directions.

NOTE The additional lines specified above are essential when setting up some microfilm scanners. They may also be used to re-scale incorrectly scaled images.

8.5.2 Document count target

The document count target shall contain the total number of images on the microfilm, thus providing a means of checking when scanning that all microimages have been detected and scanned.

8.6 Image density

The image density shall be in conformance with ISO 6200. In general, microimages on scanning microfilm shall have a density at the lower end of the permitted range, although densities lower than 0,8 may cause some loss of resolution in the scanned image.

8.7 Skew

The skew angle of microimages shall not be so large as to inhibit the use of automatic skew detection and correction after scanning. A maximum skew angle of 10° is generally acceptable.

NOTE Skew can pose problems in edge detection during scanning, especially if the trailing edge of one microimage overlaps the leading edge of the following microimage. To avoid this problem, the microimage frame used should be large enough to accommodate the extreme corners of a skewed document.

8.8 Resolution

Where practical, the resolution requirements of the microform should be calculated in accordance with Annex B.

NOTE Some applications such as engineering drawings or newspapers have specific resolution requirements. (See ISO 3272-2 and ISO 4087.)

9 Splices

Ultrasonic splices shall be used.

NOTE Cemented splices are not recommended, since they may contain chemicals that will be injurious to the long-term keeping qualities of the microfilm.

Every effort shall be made to keep the number of splices to a minimum, a maximum of six per roll is recommended. Splices shall be made in the first-generation microfilm before any duplicates are produced.

10 Document placement on the camera baseboard

Documents shall be placed so that all parts of the document lie within the designated area of the copyboard.

The skew angle of a document on the copyboard, measured as the angle between the leading edge of the document and a line at right angles to the length of the microfilm, shall be as small as practical, and shall not exceed 10°. Where appropriate, a matt black skew angle guide may be used on the copyboard.

11 Winding

After processing, the microfilm should be wound such that the image "F" shall appear in the orientation shown when viewed by the observer, see Figure 4.

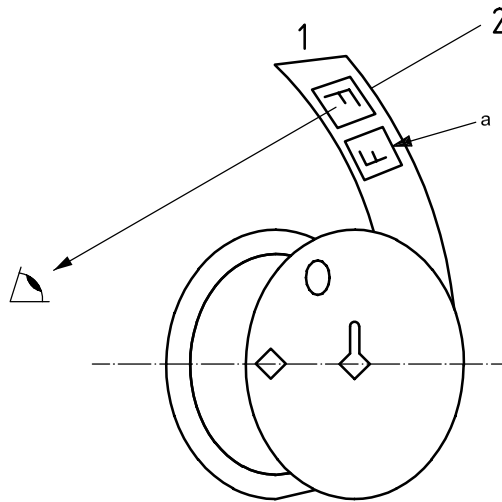

Key

- 1 leader
- 2 light

^a Orientation of scripts in Japanese, Chinese, Arabic and Hebrew languages.

Figure 4 — Diagram showing the winding of the film on the reel

12 Quality control

The quality of the microfilm and the microimages shall be inspected after processing, and any unacceptable microimages replaced (see 7.3). Where original documents are to be destroyed after microfilming, they shall be retained until this inspection and correction has been completed.

13 Legal Admissibility

Where microimages may be needed as evidence, the procedures specified in ISO 10200 should be adhered to.

Annex A (informative)

Preparation of documents

All original documents required to be microfilmed should be placed in the correct order. Every effort should be made to obtain missing items, so that the microfilm is as complete a record as possible. If missing pages or documents cannot be located, "missing document" symbols or targets should be inserted (see ISO 9878). If the size or physical form prevents certain items from being microfilmed (such as exhibits in legal files), targets identifying each item and explaining their omissions should be filmed at the appropriate places in the microfilm. Pagination may be necessary to ensure the proper order and the completeness of the document collection.

All fasteners should be removed from the documents before microfilming. If a rotary camera is used, this procedure is essential.

Imperfections that do not affect text or illustrations may be ignored. Documents with minor tears can usually be placed correctly without any loss of information. The treatment of originals is not critical if the documents are to be discarded after approved microfilming. Such non-archival documents may, if necessary, be mended with transparent adhesive tape. Major damage on archival documents should not be repaired with adhesive tape because of the possible reduction in legibility and long-term damage to the document. The document or pieces constituting a document should be placed in a clear plastic folder for microfilming. Alternatively, a copy of the document can be made using a flat-bed photocopier.

The operator of a rotary camera should be aware that adhesive from the edges of pressure-sensitive transparent tape on repaired documents can interfere with the feeding of documents, can cause paper jams, or can be transferred to the glass guides, thereby obstructing the optical path within the camera. It is recommended that adhesive tape that does not bleed be used to repair documents.

If the bindings must be taken apart and the book must be re-bound after microfilming, it is recommended that this operation be performed under the instruction of an experienced book restorer.

Stains should not be removed. Instead, photographic methods should be used to make the microimage more legible. In an attempt to improve the legibility of documents, colour filters may be used to reduce the loss of image quality that occurs if the original is discoloured and to improve the reproduction of some colours. Information (such as writing or printing) on legal or historical documents should be enhanced only by photographic methods.

Graphical symbols or targets describing the conditions of the documents and the file should be placed at the appropriate places in the sequence of documents before microfilming is started (see ISO 9878).

For any original document with density or contrast variations that require two different exposures, the "repetition of image" symbol should be included.

The document preparer should determine the number of images that are likely to fit on a roll of microfilm. This information should be used to determine at what locations in a document file a change of roll should occur. Such breaks could correspond to logical breaks within the document file, such as those at the ends of subjects, dates or volumes.

ISO 6199:2005(E)

In addition to the length and width of a roll of microfilm, the number of frames on a roll will depend on:

- the reduction ratio used;
- the size of the original document;
- the frame pitch;
- the orientation;
- the length of the roll;
- the microfilming requirements for unit records.

www.iso.org

Annex B (informative)

Resolution

B.1 General

When defining the resolution requirements of a system for producing microfilm, the issues that are relevant are as follows:

- what is the maximum reduction ratio that can be used and still produce acceptable quality images?
- what size of film should be used? (or conversely, is 16 mm film acceptable, or will 35 mm film be necessary?).

This annex gives details of procedures that, if followed, should enable the creation of microfilm that will yield good quality images.

B.2 Microfilm scanning

B.2.1 General

When scanning microfilm, the resolution of the scanning system is measured in dots per inch (dpi). When producing scanning microfilm, the resolution of the scanning system may not be known. However, it is useful to be aware of typical scanner resolutions, and their effect on the resultant scanned image.

B.2.2 Documents with grey scale

It is well established that if grey scale is to be maintained, a lower scanning resolution than with a bitonal scan will give equivalent subjective quality [4]. Although there are as yet no established quantitative rules relating grey scale to bitonal images, typically a 300 dpi, 4-bit grey-scale image (i.e. one with 16-levels) is easily achievable when scanning from high-contrast microfilm and is not greatly inferior to a 600 dpi bitonal image. This then has a bearing on the question of maximum reduction ratio and whether 16 mm as opposed to 35 mm can be used to achieve a given quality level.

B.2.3 Documents with handwritten text

The principal determinants of minimum scanning resolution requirements for handwritten text is the thickness of lines as well as the background contrast. Handwritten lines tend to be thinnest in the upstrokes, when produced with a pen nib. Such lines are typically 0,1 mm thick. It may be assumed that a minimum scanning width of two pixels, plus an increase of 50 % as a safeguard to account for detector-to-line misregistration, will detect and capture these lines.

Thus, to ensure acceptable scanned image quality, a scanning resolution of approximately 600 dpi is needed for a line that is 0,1 mm in height and of high line to background contrast. Also a required quality level of high (8) according to the classic QI formula (see B.4) is required.

B.3 Microfilm resolution

There is a relationship between microfilm resolution requirements and reduction ratios. A typical character requires a system resolution of 10 line pairs across its height to enable its recognition. Thus, by dividing the height of the smallest character to be resolved by 10, and then by the reduction ratio, the system resolution can be determined.

For example, when scanning characters of 1 mm in height, and using a reduction ratio of 1:24, a system resolution of 240 line pairs per mm (lp/mm) is appropriate.

When using scanning systems that are calibrated in dots per inch (dpi), a resolution of 500 dpi is approximately equivalent to 10 lp/mm. Thus, a scanner resolution of 12 000 dpi (240 × 50) would be appropriate in the example above.

B.4 Quality index

B.4.1 General

The quality index of a microfilm is a measure of its quality levels.

B.4.2 Calculation

Quality index is based on the evaluation of microimages of the ISO resolution Test Chart No. 2 (see ISO 3334). The ISO Test Chart No. 2 is a series of patterns with line-pair frequencies ranging from 1 lp/mm to 18 lp/mm.

For the purposes of this International Standard, the quality index, QI , of a microfilming system should be determined by the following equation:

$$QI = P \times H$$

where

P is the highest pattern number from the ISO Test Chart No. 2 resolved in the microimage;

H is the height of the lower case 'e' in the original document, in millimetres.

For excellent reproduction, in which the details of characters are clearly defined, QI should be 8 or more. If a QI of approximately 5 is obtained, the reproduction should be able to be read without difficulty, although characters with serifs or other fine details may not be well formed. If the QI is 3 or less, the reproduction may only be able, at best, to be read with difficulty, the letters 'e', 'c', and 'o' being partly closed (or worse).

A QI of 3,6 is regarded as marginal image quality.

Bibliography

- [1] ISO 3272 (all parts), *Microfilming of technical drawings and other drawing office documents*
- [2] ISO 4087, *Micrographics — Microfilming of newspapers for archival purposes on 35 mm microfilm*
- [3] ISO 12650, *Document imaging applications — Microfilming of achromatic maps on 35 mm microfilm*
- [4] KENNEY and CHAPMAN, *Tutorial on Digital Resolution Requirements for Replacing ext-Based Material*, Commission on Preservation and Access, Washington D.C., USA 1995.

© ISO 2005. All rights reserved.

ICS 37.080

Price based on 19 pages