**Rotary-shaft lip-type seals incorporating
elastomeric sealing elements —**

**Part 5:
Identification of visual imperfections**

*Bagues d'étanchéité à lèvres pour arbres tournants incorporant des
éléments d'étanchéité en élastomère —*

Partie 5: Identification des imperfections visuelles



PDF disclaimer

This PDF file may contain embedded typefaces. In accordance with Adobe's licensing policy, this file may be printed or viewed but shall not be edited unless the typefaces which are embedded are licensed to and installed on the computer performing the editing. In downloading this file, parties accept therein the responsibility of not infringing Adobe's licensing policy. The ISO Central Secretariat accepts no liability in this area.

Adobe is a trademark of Adobe Systems Incorporated.

Details of the software products used to create this PDF file can be found in the General Info relative to the file; the PDF-creation parameters were optimized for printing. Every care has been taken to ensure that the file is suitable for use by ISO member bodies. In the unlikely event that a problem relating to it is found, please inform the Central Secretariat at the address given below.



COPYRIGHT PROTECTED DOCUMENT

© ISO 2008

All rights reserved. Unless otherwise specified, no part of this publication may be reproduced or utilized in any form or by any means, electronic or mechanical, including photocopying and microfilm, without permission in writing from either ISO at the address below or ISO's member body in the country of the requester.

ISO copyright office
Case postale 56 • CH-1211 Geneva 20
Tel. + 41 22 749 01 11
Fax + 41 22 749 09 47
E-mail copyright@iso.org
Web www.iso.org

Published in Switzerland

Contents

Page

Foreword.....	iv
Introduction	v
1 Scope	1
2 Normative references	1
3 Terms and definitions	1
4 Characteristic imperfections	1
4.1 Definition of sealing lip critical area	1
4.2 Type and name of imperfections.....	2
4.3 Typical sealing edge imperfections	2
4.4 Typical sealing lip imperfections (except sealing edge)	5
4.5 Typical spring imperfections	6
4.6 Typical outside diameter imperfections	6
4.7 Typical protection lip imperfections	7
5 Identification statement (reference to this part of ISO 6194)	8
Bibliography	9

Foreword

ISO (the International Organization for Standardization) is a worldwide federation of national standards bodies (ISO member bodies). The work of preparing International Standards is normally carried out through ISO technical committees. Each member body interested in a subject for which a technical committee has been established has the right to be represented on that committee. International organizations, governmental and non-governmental, in liaison with ISO, also take part in the work. ISO collaborates closely with the International Electrotechnical Commission (IEC) on all matters of electrotechnical standardization.

International Standards are drafted in accordance with the rules given in the ISO/IEC Directives, Part 2.

The main task of technical committees is to prepare International Standards. Draft International Standards adopted by the technical committees are circulated to the member bodies for voting. Publication as an International Standard requires approval by at least 75 % of the member bodies casting a vote.

Attention is drawn to the possibility that some of the elements of this document may be the subject of patent rights. ISO shall not be held responsible for identifying any or all such patent rights.

ISO 6194-5 was prepared by Technical Committee ISO/TC 131, *Fluid power systems*, Subcommittee SC 7, *Sealing devices*.

This second edition cancels and replaces the first edition (ISO 6194-5:1990) which has been technically revised.

ISO 6194 consists of the following parts, under the general title *Rotary-shaft lip-type seals incorporating elastomeric sealing elements*:

- *Part 1: Nominal dimensions and tolerances*
- *Part 2: Vocabulary*
- *Part 3: Storage, handling and installation*
- *Part 4: Performance test procedures*
- *Part 5: Identification of visual imperfections*

Introduction

Rotary-shaft lip-type seals are used to retain fluid, e.g. lubricant, in equipment where the differential pressure is relatively low. Typically, the shaft rotates and the housing is stationary, although in some applications the shaft is stationary and the housing rotates.

Dynamic sealing is normally the result of a designed interference fit between the shaft and a flexible element incorporated in the seal.

Similarly, a designed interference fit between the outside diameter of the seal and the diameter of the housing bore retains the seal and prevents static leakage.

Careful storage, handling, and proper installation of all seals are necessary to avoid hazards, both prior to and during installation, which can adversely affect service life.

Rotary-shaft lip-type seals incorporating elastomeric sealing elements —

Part 5: Identification of visual imperfections

1 Scope

This part of ISO 6194 describes seals utilizing elastomeric sealing elements. They are normally considered suitable for use only at low pressures (see ISO 6194-1:2007, 6.1).

This part of ISO 6194 defines and classifies typical surface imperfections that can impair the function of the seals and is intended as a convenience for purchasers and manufacturers in their discussions concerning the importance of these imperfections in different applications.

NOTE ISO 6194 (all parts) is complementary to ISO 16589 (all parts), which covers seals incorporating thermoplastic sealing elements.

2 Normative references

The following referenced documents are indispensable for the application of this document. For dated references, only the edition cited applies. For undated references, the latest edition of the referenced document (including any amendments) applies.

ISO 5598, *Fluid power system and components — Vocabulary*

ISO 6194-2, *Rotary-shaft lip-type seals incorporating elastomeric sealing elements — Part 2: Vocabulary*

3 Terms and definitions

For the purposes of this document, the terms and definitions given in ISO 5598 and ISO 6194-2 apply.

4 Characteristic imperfections

4.1 Definition of sealing lip critical area

See Figure 1 and Table 1.

Dimensions x and y were chosen because, in cases of wear, imperfections in this area can impair the function of the rotary-shaft lip-type seal during its lifetime.

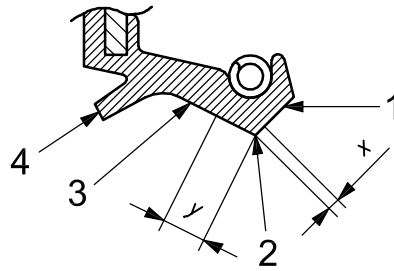

Key

- 1 lip fluid side
- 2 sealing edge
- 3 lip air side
- 4 optional protection lip

NOTE The values for *x* and *y* are given in Table 1.

Figure 1 — Sealing lip critical area

Table 1 — Typical dimensions of sealing lip critical area

Dimensions in millimeters

Shaft diameter <i>d</i> ₁	<i>x</i> ^a	<i>y</i> ^a
<i>d</i> ₁ ≤ 50	0,6	1,2
50 < <i>d</i> ₁ ≤ 120	0,8	1,5
<i>d</i> ₁ > 120	1	2

^a These are typical values; specific values shall be agreed to between purchasers and suppliers.

4.2 Type and name of imperfections

See Figure 2.

4.3 Typical sealing edge imperfections

See Figure 2 and Figures 3 to 14 for the following types of imperfections; keyed elements are identified in Figure 2:

- inclusion (see Figures 3, 4, and 5);
- crack (see Figure 6);
- rough trim (see Figure 7);
- step trim (see Figure 8);
- nick (see Figure 9);
- knit line (see Figure 10);
- tear (see Figure 11);
- cut (see Figure 12);
- filler projection (see Figure 13);
- stuck flash (see Figure 14).

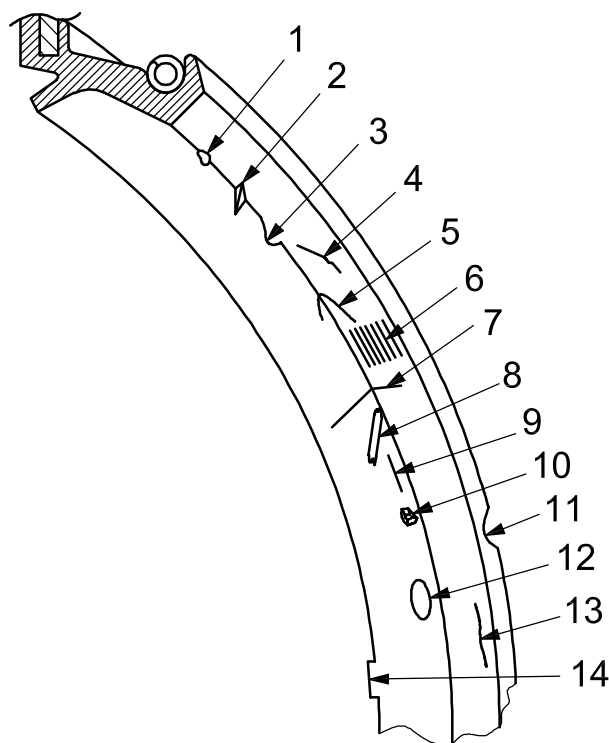

Key

- | | | | |
|-------------|---------------|----------------------|-------------------------------------|
| 1 inclusion | 5 crack | 9 cut | 13 split |
| 2 nick | 6 rough trim | 10 filler projection | 14 flash on optional protection lip |
| 3 step trim | 7 knit line | 11 non-fill | |
| 4 tear | 8 stuck flash | 12 blister | |

Figure 2 — Type and name of imperfections

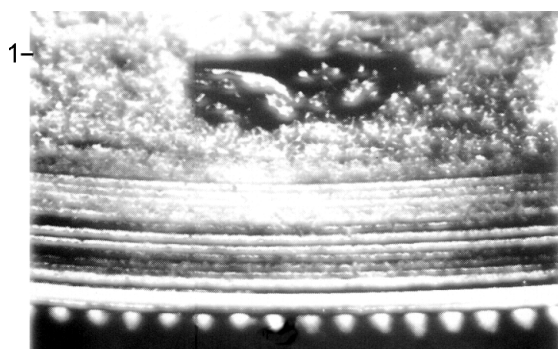

Figure 3 — Inclusion: flash

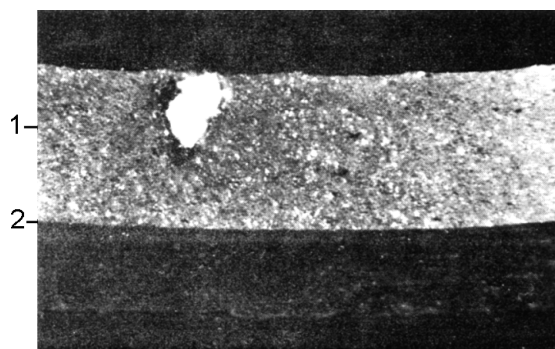

Figure 4 — Inclusion: filler



Figure 5 — Inclusion: foreign material



Figure 6 — Crack

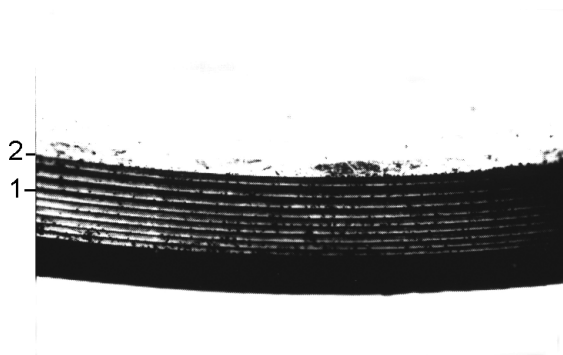

Figure 7 — Rough trim



Figure 8 — Step trim

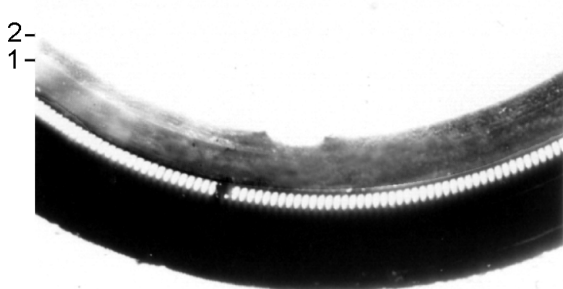

Figure 9 — Nick

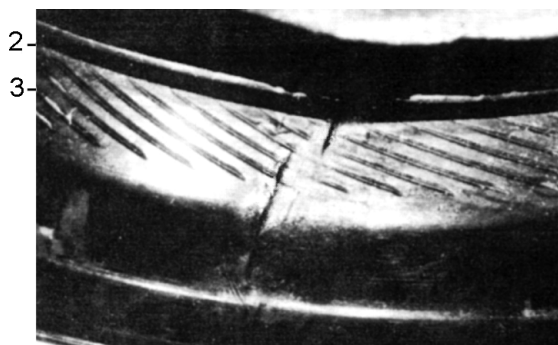

Figure 10 — Knit line

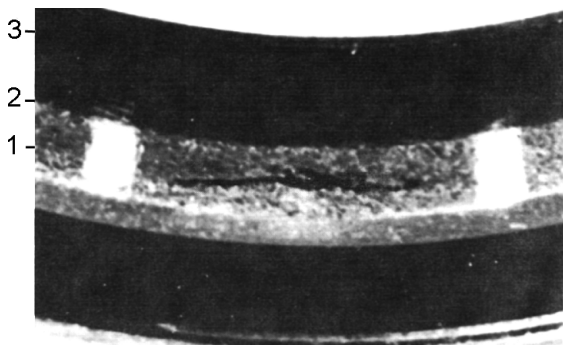

Figure 11 — Tear



Figure 12 — Cut

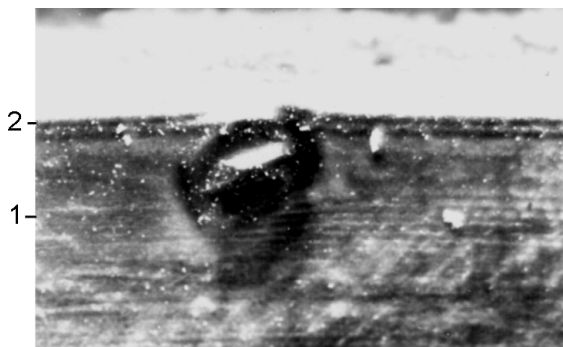

Figure 13 — Filler projection

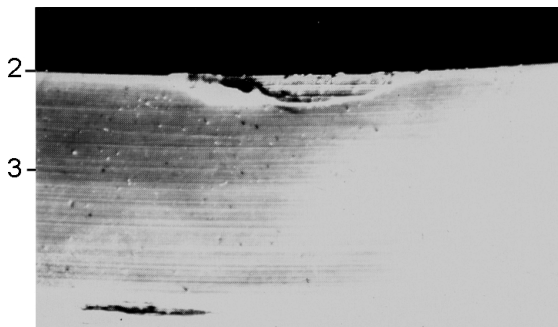

Figure 14 — Stuck flash

4.4 Typical sealing lip imperfections (except sealing edge)

See Figure 2 and Figures 15 to 20 for the following types of imperfections; keyed elements are identified in Figure 2:

- split (see Figure 15);
- stuck flash (see Figure 16);
- non-fill (see Figure 17);
- crack (see Figure 18);
- tear (see Figure 19);
- blister (see Figure 20).

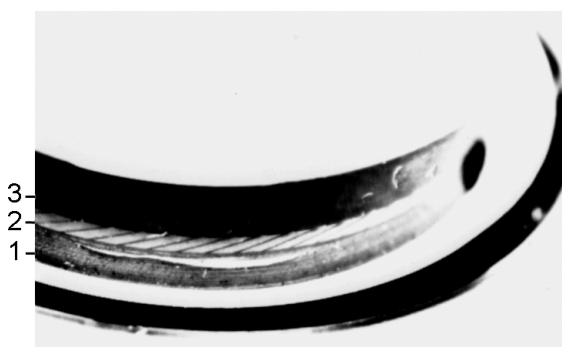

Figure 15 — Split

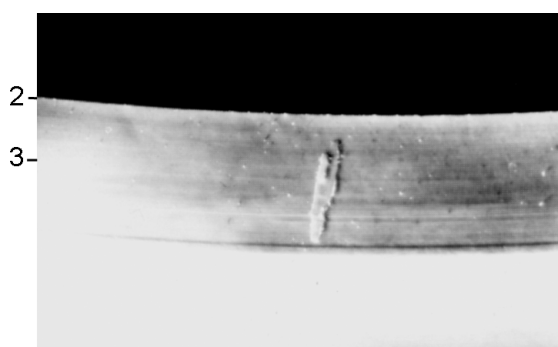

Figure 16 — Stuck flash

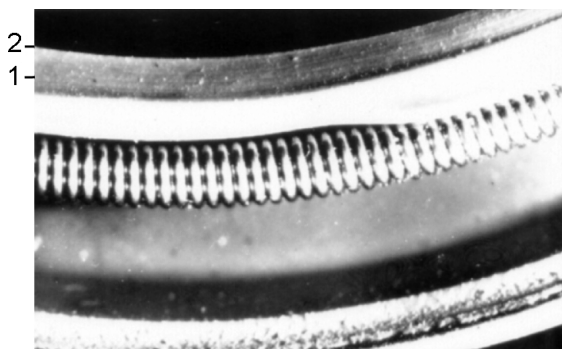

Figure 17 — Non-fill

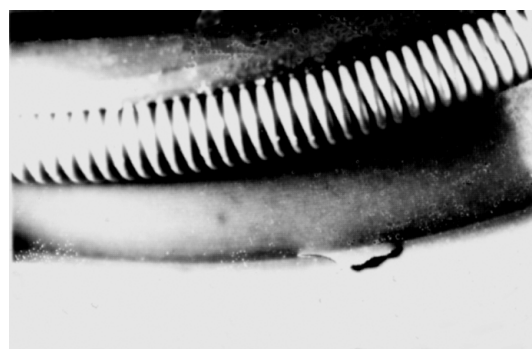

Figure 18 — Crack



Figure 19 — Tear



Figure 20 — Blister

4.5 Typical spring imperfections

See Figures 21 to 23 for the following types of imperfections; keyed elements are identified in Figure 2:

- deformed spring (see Figure 21);
- spring with stretched coil portion (see Figure 22);
- spring with incomplete joint portion (see Figure 23).

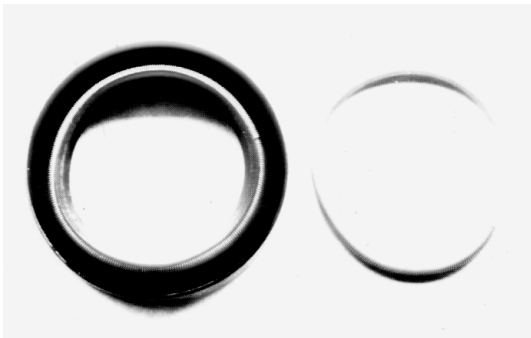

Figure 21 — Deformed spring



Figure 22 — Spring with stretched coil portion

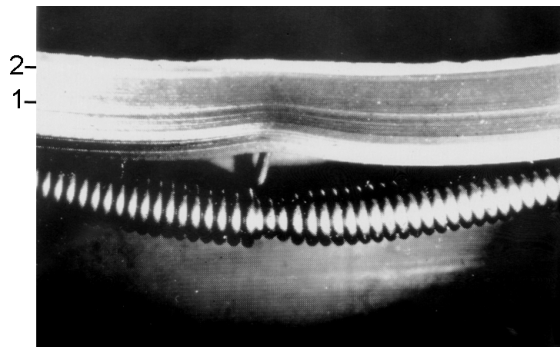

Figure 23 — Spring with incomplete joint portion

4.6 Typical outside diameter imperfections

See Figures 24 to 26 for the following types of imperfections; keyed elements are identified in Figure 2:

- scratch (see Figure 24);
- incorrect chamfer (see Figure 25);
- incomplete bond (see Figure 26).



Figure 24 — Scratch

Figure 25 — Incorrect lead-in chamfer
on seal outside diameter

Figure 26 — Incomplete bond

4.7 Typical protection lip imperfections

See Figures 27 to 30 for the following types of imperfections; keyed elements are identified in Figure 2:

- tear (see Figure 27);
- cut or nick (see Figure 28);
- non-fill (see Figure 29);
- flash (see Figure 30).

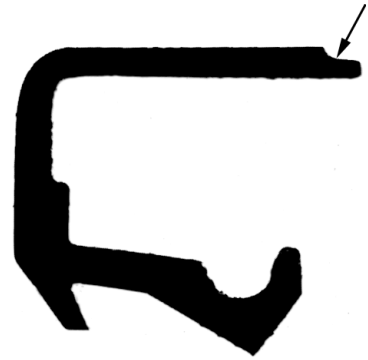
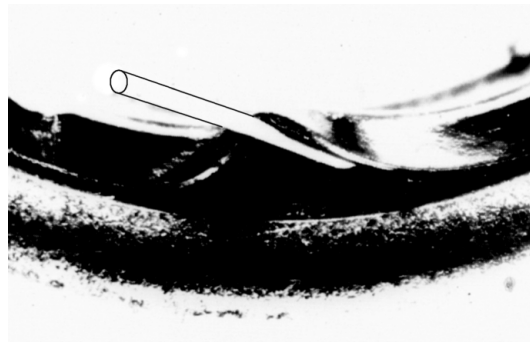

Figure 27 — Tear

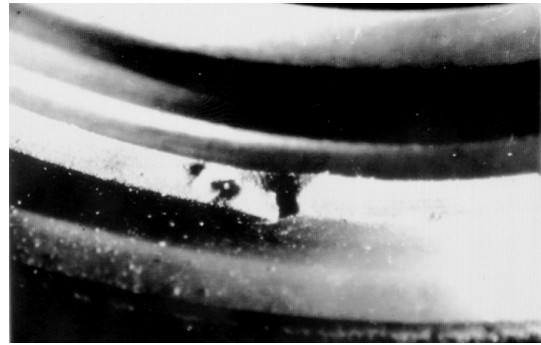

Figure 28 — Cut or nick

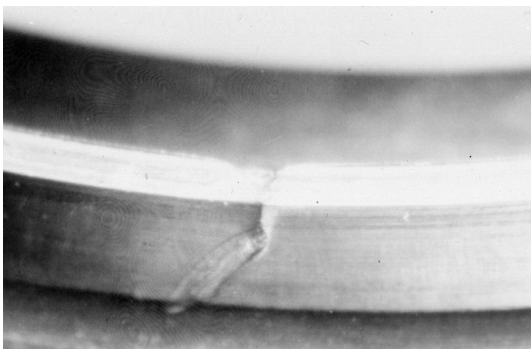

Figure 29 — Non-fill

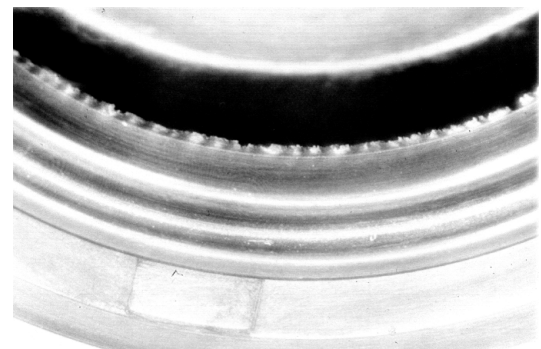

Figure 30 — Flash

5 Identification statement (reference to this part of ISO 6194)

It is strongly recommended that manufacturers use the following statement in test reports, catalogues and sales literature when electing to comply with this part of ISO 6194:

“Visual imperfection identification is in accordance with ISO 6194-5, *Rotary-shaft lip-type seals incorporating elastomeric sealing elements — Part 5: Identification of visual imperfections.*”

Bibliography

- [1] ISO 6194-1:2007, *Rotary-shaft lip-type seals incorporating elastomeric sealing elements — Part 1: Nominal dimensions and tolerances*
- [2] ISO 6194-3¹⁾, *Rotary-shaft lip-type seals incorporating elastomeric sealing elements — Part 3: Storage, handling and installation*
- [3] ISO 6194-4¹⁾, *Rotary-shaft lip-type seals incorporating elastomeric sealing elements — Part 4: Performance test procedures*
- [4] ISO 16589-1, *Rotary shaft lip-type seals incorporating thermoplastic sealing elements — Part 1: Nominal dimensions and tolerances*
- [5] ISO 16589-2, *Rotary shaft lip-type seals incorporating thermoplastic sealing elements — Part 2: Vocabulary*
- [6] ISO 16589-3, *Rotary shaft lip-type seals incorporating thermoplastic sealing elements — Part 3: Storage, handling and installation*
- [7] ISO 16589-4, *Rotary shaft lip-type seals incorporating thermoplastic sealing elements — Part 4: Performance test procedures*
- [8] ISO 16589-5, *Rotary shaft lip-type seals incorporating thermoplastic sealing elements — Part 5: Identification of visual imperfections*

1) To be published.

