Inflatable boats —

Part 3:

**Boats with a maximum motor power rating
of 15 kW and greater**

Bateaux pneumatiques —

*Partie 3: Bateaux équipés d'un moteur d'une puissance maximale
supérieure ou égale à 15 kW*



Reference number
ISO 6185-3:2001(E)

© ISO 2001

PDF disclaimer

This PDF file may contain embedded typefaces. In accordance with Adobe's licensing policy, this file may be printed or viewed but shall not be edited unless the typefaces which are embedded are licensed to and installed on the computer performing the editing. In downloading this file, parties accept therein the responsibility of not infringing Adobe's licensing policy. The ISO Central Secretariat accepts no liability in this area.

Adobe is a trademark of Adobe Systems Incorporated.

Details of the software products used to create this PDF file can be found in the General Info relative to the file; the PDF-creation parameters were optimized for printing. Every care has been taken to ensure that the file is suitable for use by ISO member bodies. In the unlikely event that a problem relating to it is found, please inform the Central Secretariat at the address given below.

© ISO 2001

All rights reserved. Unless otherwise specified, no part of this publication may be reproduced or utilized in any form or by any means, electronic or mechanical, including photocopying and microfilm, without permission in writing from either ISO at the address below or ISO's member body in the country of the requester.

ISO copyright office
Case postale 56 • CH-1211 Geneva 20
Tel. + 41 22 749 01 11
Fax + 41 22 749 09 47
E-mail copyright@iso.ch
Web www.iso.ch

Printed in Switzerland

Contents

Page

Foreword.....	v
Introduction.....	vi
1 Scope	1
2 Normative references	1
3 Terms and definitions	2
4 Materials	3
4.1 General	3
4.2 Reinforced materials making up the hull (excluding glass-fibre-reinforced plastics components)	3
4.2.1 Requirements	3
4.2.2 Test methods	4
4.3 Wood	5
4.3.1 General	5
4.3.2 Plywood	5
4.3.3 Constructional timbers	6
4.4 Metal and synthetic material parts	6
4.5 Glass-fibre-reinforced plastics	6
5 Functional components	6
5.1 Conditioning	6
5.2 Hull fittings	6
5.2.1 Requirement	6
5.2.2 Test method	6
5.3 Manual lifting and carrying devices	6
5.3.1 Requirement	6
5.3.2 Test method	6
5.4 Valves	7
5.4.1 Inflation	7
5.4.2 Deflation	7
5.5 Rowlocks and oars	7
5.5.1 Requirements	7
5.5.2 Abrasion damage	7
5.5.3 Prevention from loosening	7
5.5.4 Strength of rowlocks	8
5.5.5 Use of the rowlocks and oars	8
5.6 Transom (where applicable)	8
5.6.1 Requirement	8
5.6.2 Test method	8
5.7 Hull drainage	8
5.8 Remote steering system (where offered as standard or optional equipment)	8
5.9 Motor-securing line attachment (outboard engines only)	9
5.10 Towing device (all types)	9
5.11 Seating and attachment systems (where offered as a standard or optional equipment)	9
5.12 Electrical installations (where offered as standard or optional equipment))	9
5.13 Fuel systems (where applicable)	9
5.14 Ventilation of petrol motor and petrol tank compartments (where applicable)	9
6 Safety requirements of the completed boat	9
6.1 Maximum permissible number of persons	9
6.2 Maximum motor power	10
6.3 Static stability of the boat	10

6.3.1	Requirement	10
6.3.2	Test method.....	10
6.3.3	Stability factor (Type VIII boats only).....	11
6.4	Maximum load capacity.....	11
6.4.1	Requirement	11
6.4.2	Test method.....	12
6.5	Design working pressures	12
6.6	Strength of the hull	12
6.6.1	Requirement	12
6.6.2	Test method.....	12
6.7	Safety ropes and grab handles.....	13
6.7.1	Requirement	13
6.7.2	Test method.....	13
6.8	Residual buoyancy	13
6.8.1	Requirement	13
6.8.2	Test method.....	13
6.9	Manoeuvrability.....	13
6.9.1	Requirement	13
6.9.2	Test method.....	13
6.10	Compartmentation	13
6.11	Field of vision from the helm position.....	14
6.12	Provision for (a) liferaft(s) (Type VIII boats only).....	14
7	Performance test.....	14
7.1	General.....	14
7.2	Drop test (RIBs only)	15
7.2.1	Requirement	15
7.2.2	Test method.....	15
7.3	In-water performance	15
7.3.1	Requirement	15
7.3.2	Test methods.....	16
7.4	Strength of the towing device	16
7.4.1	Requirement	16
7.4.2	Test method.....	16
7.5	Rowing test (where applicable, see 5.5)	17
7.6	Watertightness test (not applicable to open floor, self-bailing craft).....	17
7.6.1	Requirement	17
7.6.2	Test method.....	18
7.7	Manoeuvring-speed test.....	18
7.8	Bailing test (Type VIII boats only)	18
7.8.1	Requirement	18
7.8.2	Test method.....	18
8	Builder's plate(s).....	18
9	Operator's instructions and warning notes	19
10	Standard equipment	20
Annex A (informative)	General arrangement of a typical type VII boat.....	21
Annex B (informative)	General arrangement of a typical Type VIII boat	22
Bibliography	23

Foreword

ISO (the International Organization for Standardization) is a worldwide federation of national standards bodies (ISO member bodies). The work of preparing International Standards is normally carried out through ISO technical committees. Each member body interested in a subject for which a technical committee has been established has the right to be represented on that committee. International organizations, governmental and non-governmental, in liaison with ISO, also take part in the work. ISO collaborates closely with the International Electrotechnical Commission (IEC) on all matters of electrotechnical standardization.

International Standards are drafted in accordance with the rules given in the ISO/IEC Directives, Part 3.

Draft International Standards adopted by the technical committees are circulated to the member bodies for voting. Publication as an International Standard requires approval by at least 75 % of the member bodies casting a vote.

Attention is drawn to the possibility that some of the elements of this part of ISO 6185 may be the subject of patent rights. ISO shall not be held responsible for identifying any or all such patent rights.

International Standard ISO 6185-3 was prepared by Technical Committee ISO/TC 188, *Small craft*.

ISO 6185-3, together with ISO 6185-1 and ISO 6185-2, cancel and replace ISO 6185:1982.

They differ significantly from ISO 6185:1982 as they cover boats from unsupported materials, whereas the latter only covered boats made from reinforced materials.

ISO 6185 consists of the following parts, under the general title *Inflatable boats*:

- *Part 1: Boats with a maximum motor power rating of 4,5 kW*
- *Part 2: Boats with a maximum motor power rating of 4,5 kW to 15 kW inclusive*
- *Part 3: Boats with a maximum motor power rating of 15 kW and greater*

Annexes A and B of this part of ISO 6185 are for information only.

Introduction

ISO 6185 is subdivided into three parts as shown in Figure 1.

It excludes

- single-chambered boats,
- boats of buoyancy less than 1 800 N,
- boats made from unsupported materials of more than 12 kN inflated buoyancy and powered by motors exceeding 4,5 kW and
- boats greater than 8 m in overall length.

It is not applicable to

- aquatic toys, and
- inflatable liferafts.

Part 1:

- | | |
|----------|---|
| Type I | Boats propelled exclusively by manual means. |
| Type II | Powered boats not exceeding 4,5 kW. |
| Type III | Canoes and kayaks. |
| Type IV | Sail craft with a maximum sail area of 6 m ² . |

Part 2:

- | | |
|---------|---|
| Type V | Powered boats of 4,5 kW to 15 kW inclusive. |
| Type VI | Sail craft with sail area greater than 6 m ² . |

Part 3:

- | | |
|-----------|--|
| Type VII | Powered boats of 15 kW and greater. |
| Type VIII | Powered offshore boats of 75 kW and greater. |

.....

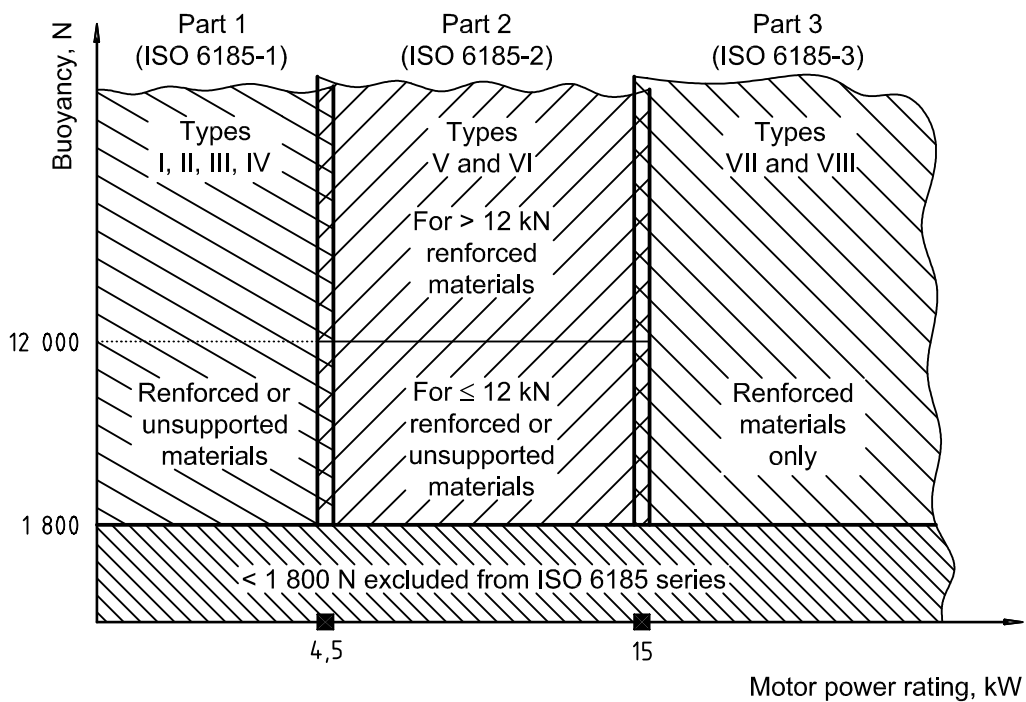

Figure 1 — Illustration of how the three parts of ISO 6185 are divided

Inflatable boats —

Part 3:

Boats with a maximum motor power rating of 15 kW and greater

1 Scope

This part of ISO 6185 specifies the minimum safety characteristics required for the design, materials to use, manufacture and testing of inflatable boats (including rigid inflatable boats) less than 8 m in overall length with a minimum buoyancy of 1 800 N.

This part of ISO 6185 is applicable to the following types of inflatable boats intended for use within the operating temperatures of $-20\text{ }^{\circ}\text{C}$ to $+60\text{ }^{\circ}\text{C}$:

- Type VII: Inflatable boats capable of taking a motor power rating of 15 kW and greater;
- Type VIII: Inflatable offshore boats capable of taking a motor power rating of 75 kW or greater and with a stability factor greater than 250.

NOTE 1 General arrangements of typical boats of Types VII and VIII are given in annexes A and B, respectively.

NOTE 2 For boats with power ratings of 4,5 kW and less refer to ISO 6185-1. For boats with power ratings of 4,5 kW to 15 kW inclusive refer to ISO 6185-2.

This part of ISO 6185 excludes single-chambered boats and boats made from unsupported materials, and is not applicable to aquatic toys and inflatable liferafts.

2 Normative references

The following normative documents contain provisions which, through reference in this text, constitute provisions of this part of ISO 6185. For dated references, subsequent amendments to, or revisions of, any of these publications do not apply. However, parties to agreements based on this part of ISO 6185 are encouraged to investigate the possibility of applying the most recent editions of the normative documents indicated below. For undated references, the latest edition of the normative document referred to applies. Members of ISO and IEC maintain

ISO 1817:1999, *Rubber, vulcanized — Determination of the effect of liquids*

ISO 2411:2000, *Rubber- or plastics-coated fabrics — Determination of coating adhesion*

ISO 3011:1997, *Rubber- or plastics-coated fabrics — Determination of resistance to ozone cracking under static conditions*

ISO 4646:1989, *Rubber- or plastics-coated fabrics — Low-temperature impact test*

ISO 4674:1977, *Fabrics coated with rubber or plastics — Determination of tear resistance*

ISO 7000:1989, *Graphical symbols for use on equipment — Index and synopsis*

ISO 6185-3:2001(E)

ISO 8665:1994, *Small craft — Marine propulsion motors and systems — Power measurements and declarations*

ISO 8848:1990, *Small craft — Remote steering systems*

ISO 8849:1990, *Small craft — Electrically operated bilge pumps*

ISO 9097:1991, *Small craft — Electric fans*

ISO 9775:1990, *Small craft — Remote steering systems for single outboard motors of 15 kW to 40 kW power*

ISO 10088:2001, *Small craft — Permanently installed fuel systems and fixed fuel tanks*

ISO 10133:2000, *Small craft — Electrical systems — Extra-low-voltage d.c. installations*

ISO 10592:1994, *Small craft — Hydraulic steering systems*

ISO 11105:1997, *Small craft — Ventilation of petrol motor and/or petrol tank compartments*

ISO 11192:—¹⁾, *Small craft — Graphical symbols*

ISO 11591:2000, *Small craft, engine driven — Field of vision from helm position*

ISO 11592:2001, *Small craft of hull length less than 8 m — Determination of maximum propulsion power rating*

ISO 12215-1:2000, *Small craft — Hull construction and scantlings — Part 1: Materials: Thermosetting resins, glass-fibre reinforcement, reference laminate*

ISO 15652:—¹⁾, *Small craft — Remote steering systems for inboard mini jet boats*

Colreg 72, *Convention on the international regulations for preventing collisions at sea*

3 Terms and definitions

For the purposes of this part of ISO 6185, the following terms and definitions apply.

3.1

inflatable boat

buoyant structure (hull), achieving all or part of its intended shape and buoyancy by the medium of inflation and which is intended for the transportation of people and/or loads on the water, and where the design and shape of it gives it the capability of withstanding forces and movements arising from sea conditions

3.2

rigid inflatable boat

RIB

inflatable boat (3.1) but the lower part of the hull constructed as a rigid unit and the topsides (inflatable hull) achieving its intended shape and buoyancy (or part thereof) by the medium of inflation

3.3

buoyancy of the boat

volume of any chamber, which forms the inflatable hull, and any other chamber which is permanently fixed to it

1) To be published.

3.4**buoyancy of a RIB**

the buoyancy comprising, for calculation purposes, in addition to the inflated buoyancy, the permanent inherent buoyancy or at least two compartments of permanent sealed buoyancy, fixed to the rigid hull, not exceeding 20 % of the total buoyancy

3.5**calculation of the buoyancy**

determination of buoyancy by measuring or calculating the volume at the design working pressure recommended by the manufacturer and expression as a force, where required

NOTE The conversion factor is 9,81 kN/m³ of the total buoyancy.

3.6**permanent inherent buoyancy**

non-intercellular (closed-cell) foam or other materials which are less dense than fresh water and which have minimal water absorption over their intended life expectancy and which are in (a) sealed compartment(s) in the hull

3.7**permanent sealed buoyancy**

sealed airtight compartment(s) filled with air

3.8**reinforced materials**

materials which have a coated base cloth

3.9**inboard area**

internal surface area defined by a vertical plane tangential to the innermost side of the buoyancy tube and perpendicular to the deck

3.10**offshore inflatable boat**

boat that is largely self-sufficient and capable of offshore voyages where conditions up to and including wind force 8 and significant wave heights of up to 4 m may be experienced

4 Materials**4.1 General**

All materials shall be selected by the manufacturer according to the stresses to which the craft is to be subjected (shape, dimensions, maximum load, installed power, etc.), and also to the intended service conditions. Use under normal seagoing conditions shall not materially impair their performance and they shall meet the requirements specified in 4.2 to 4.5.

All materials of the inflatable boat shall be inherently rotproof

4.2 Reinforced materials making up the hull (excluding glass-fibre-reinforced plastics components)**4.2.1 Requirements**

All materials contributing to the integrity of the boat shall meet the requirements stipulated below and shall retain their full serviceability within the operating temperature range of – 20 °C to + 60 °C.

4.2.2 Test methods

4.2.2.1 Sampling

Carry out the test with test pieces taken from the constituent materials prior to manufacturing the boat. If the boats are vulcanized during manufacture, the test pieces shall also be vulcanized.

4.2.2.2 Resistance to liquids

Carry out the test on the external side or the sides of the material in contact with the ambient environment as specified in ISO 1817 but using ASTM oil No. 1.

In cases a) and b) shown in Table 1, the change in mass per unit area shall not exceed 100 g/m² following the stipulated period of contact with the test fluid at a temperature of 70 °C ± 2 °C.

Table 1 — Test liquids

Test liquid	Period of contact
a) Oil	22 h ± 0,25 h
b) Salt water ^a	336 h (minimum)
^a Components of salt water: Distilled water + 30 g of sodium chloride per litre.	

No reproduction or networking permitted without license from IHS

4.2.2.3 Resistance to ozone

Carry out the test on the external side or the sides in contact with the ambient environment as specified in ISO 3011.

- Exposure time: 72 h
- Temperature of test: 30 °C ± 2 °C
- Concentration: 50 pphm²⁾, that is to say, a volume fraction of 0,5 × 10⁻⁶
- Mandrel diameter: 5 times the material thickness

There shall be no signs of cracking on completion of the test when the test samples are examined under a magnification of 10 ×.

4.2.2.4 Resistance to cold

All materials shall satisfy the requirements of ISO 4646 at a temperature of -20 °C.

4.2.2.5 Tear strength

Carry out the test as specified in ISO 4674:1977, method A2. The minimum value of tear resistance, in newtons, is given by the formula.

$$0,375d (1,14p + 0,14)$$

2) Parts of ozone per hundred million of air by volume.

where

d is the maximum tube diameter, in millimetres, measured within the straight sections of the buoyancy tube section;

p is the recommended working pressure, in bars, at 20 °C.

In all cases, the minimum value shall be not less than 75 N.

4.2.2.6 Coating adhesion

Carry out the test in accordance with ISO 2411 at room temperature and a machine rate of 100 mm/min \pm 10 mm/min. The minimum adhesion value shall be 40 N per 25 mm. Prepare the test strips in accordance with ISO 2411.

Alternatively, it is permissible to cut a test strip 25 mm wide by extending cuts A and B and ignoring cut C. In order for the test strips to be gripped, 50 mm shall be left unbonded at one end. The test piece is "peeled" at 100 mm/min \pm 10 mm/min and the surface coating cut back to the fabric and allowed to run down the fabric/coating interface for at least 25 mm.

4.2.2.7 Seam strength testing of buoyancy chambers

Join two pieces of material together in the same manner as used in the boat construction (method, material, dimensions) to form a 50 mm wide test piece. Apply a static load at 60 °C over a period of 4 h. Where more than one method of seam construction is used in the manufacture of the boat, carry out the test for each method.

The value of the load, in newtons, is given by the formula.

$$3,75d (1,14p + 0,14)$$

where

d is the maximum tube diameter, in millimetres, measured within the straight sections of the buoyancy tube system;

p is the recommended working pressure, in bars, at 20 °C.

There shall be no slipping or other failure at any part of the seam.

4.3 Wood

4.3.1 General

The types of timber and plywood used shall be suitable for the application and the marine environment.

All exposed timber and plywood shall be given weathertight protection, such as paint, varnish or preservative, suitable for a marine environment.

4.3.2 Plywood

All plywood used shall incorporate only hardwoods for both internal and external veneers and the bonding adhesive shall be waterproof and boil proof.

The timber used shall be seasoned and free from sapwood, decay, insect attack, splits and other imperfections likely to adversely affect the performance of the material. The timber shall be generally free from knots but an occasional sound intergrown knot is acceptable.

Other timbers, e.g. Douglas fir, may be used for the veneers provided that they are treated to give protection against rot, fungal decay and marine borers. Adjoining edges and/or surfaces, including any end-grain, shall be effectively sealed.

4.3.3 Constructional timbers

The timber used in the construction shall be seasoned and free from sapwood, shakes and other defects.

4.4 Metal and synthetic material parts

Materials used shall be of a type, strength and finish suitable for the intended purpose of the components and compatible with the marine environment.

4.5 Glass-fibre-reinforced plastics

Resins, reinforcements and laminates shall comply with the requirements of ISO 12215-1.

5 Functional components

5.1 Conditioning

All tests shall be performed at a temperature of $20\text{ °C} \pm 3\text{ °C}$.

5.2 Hull fittings

5.2.1 Requirement

The materials and method of construction used shall be compatible with that of the hull itself. Any load-bearing fitting attached to the boat (see 3.1 and 3.2) shall not, when loaded as described in 5.2.2, result in any impairment in airtightness or water integrity.

5.2.2 Test method

Any cordage used for test purposes shall have a diameter of 8 mm.

Gradually load the fittings in any direction up to breaking point but not exceeding 2 kN. If 2 kN is reached, maintain this load for 1 min.

5.3 Manual lifting and carrying devices

5.3.1 Requirement

Boats with a buoyancy less than 9 000 N shall be equipped with a means of carrying it. The fitting of lifting and carrying devices on boats with a buoyancy of 9 000 N or greater is optional. There shall be no failure of the device when tested as described in 5.3.2.

5.3.2 Test method

Any cordage used for test purposes shall have a diameter of 8 mm.

Gradually load the device with a force of 1,5 kN for 1 min in the appropriate directions.

Where lifting or carrying devices also function as safety ropes or grab handles, they shall also conform to the requirements of 6.7.1.

5.4 Valves

5.4.1 Inflation

The assemblies shall be made of corrosion-resistant materials and shall not be capable of damaging the boat materials.

The type and arrangement of the inflation valves fitted to an inflatable boat shall ensure that

- a) the valves will be readily accessible for connection of the inflation device whether the boat is on land or in the water,
- b) the valves will not inconvenience the persons in their predetermined seating positions,
- c) the valves will not interfere with the operation of the boat,
- d) the valves will not interfere with loading and unloading of the boat,
- e) the valves cannot be damaged or torn off by lines, lifelines or movable components of the boat construction or by normal movements of the passengers and load,
- f) the valves shall be equipped with a cap that can independently seal the valve and that the cap shall be connected to the valve in a secure manner that prevents it from being accidentally lost, and
- g) a controlled reduction in buoyancy-chamber pressure and of measuring that pressure is possible.

5.4.2 Deflation

Deflation of the hull shall be by manual operation, either by using the inflation valve or by using a separate device.

Where separate devices are fitted then these shall be made of corrosion-resistant materials and shall not be capable of damaging the boat material. The design and location of such devices shall meet the requirements of 5.4.1 b) to e) inclusive.

The deflation of any one compartment shall not cause a loss of air or gas from any of the remaining compartments.

5.5 Rowlocks and oars

5.5.1 Requirements

The provision of rowlocks and oars is not mandatory. If they are provided as standard or optional equipment, they shall meet the requirements, given in 5.5.2 to 5.5.5.

5.5.2 Abrasion damage

The bearing surfaces of the oars and rowlocks shall be free from any roughness likely to cause wear. All external surfaces of the rowlock shall be smooth and free from sharp edges and corners likely to cause damage when the craft is packed.

5.5.3 Prevention from loosening

Rowlocks shall be secured against unintended loosening. Means shall be provided for location of two oars or paddles when stowed away.

5.5.4 Strength of rowlocks

5.5.4.1 Requirement

There shall be no structural failure of the rowlock or associated fittings when tested as described in 5.5.4.2.

5.5.4.2 Test method

Any cordage used for test purposes shall have a diameter of 8 mm.

Load the rowing fitting, including the rowlock, with a force of 500 N for 1 min in any horizontal direction.

5.5.5 Use of the rowlocks and oars

When tested as described in 7.5, there shall be no structural failures or permanent deformation of any component during the test and it shall be clearly demonstrated that the rowlock system is rigid enough for efficient rowing.

A minimum unrestricted movement of the oars 60° ahead and 60° astern shall be required.

5.6 Transom (where applicable)

5.6.1 Requirement

The transom or motor mount and its attachment to the boat shall be designed to withstand, under normal use, the maximum stresses arising from

- the output power and torque of the motor(s) specified by the manufacturer, and
- the weight of such motor(s).

5.6.2 Test method

Visual inspection during and following in-water performance tests described in 7.3.

5.7 Hull drainage

If the boat is fitted with a transom, it shall be equipped with at least one drainplug or one bailing system.

For RIBs fitted with an integral closed hull/deck assembly which is not filled with closed-cell foam or equivalent, a facility shall be provided for draining the interior part of the hull (bilge).

Type VIII boats shall be capable of having totally flooded deck areas bailed or drained overboard without the use of a bilge pump (unless with a permanently installed manual bilge pump) in less than 3 min. See bailing test in 7.8.

5.8 Remote steering system (where offered as standard or optional equipment)

Any remote steering system shall conform to the requirements of one or more of the following International Standards: ISO 8848, ISO 9775, ISO 10592 or ISO 15652.

There shall be no damage or malfunction to either the system or to any related attachments to the boat when tested in accordance with clause 7.

Type VIII boats shall be fitted with a factory installed remote steering system.

5.9 Motor-securing line attachment (outboard engines only)

A means for attaching a motor-securing line shall be provided at an appropriate position.

5.10 Towing device (all types)

All boats shall have, at their bow, a towing device suitable for securing a towline. See 7.4 for strength test.

5.11 Seating and attachment systems (where offered as a standard or optional equipment)

There shall be no damage or malfunction to either the seating or to any related attachment systems when tested in accordance with clause 7.

Type VIII boats have a factory-installed seating and attachment system.

5.12 Electrical installations (where offered as standard or optional equipment)

Any electrical installations shall conform to the requirements of the following International Standards, as applicable: ISO 10133, ISO 9097 or ISO 8849.

Type VIII boats shall be fitted with a factory-installed electrical system that conforms to ISO 10133.

Navigation lights, if fitted, shall meet the requirements of Colreg 72.

5.13 Fuel systems (where applicable)

Permanently installed fuel systems and fixed fuel tanks shall conform to ISO 10088.

Type VIII boats shall be fitted with a factory-installed permanent fuel system including permanent fuel tank(s).

5.14 Ventilation of petrol motor and petrol tank compartments (where applicable)

Ventilation of petrol motor and petrol tank compartments shall conform to ISO 11105.

6 Safety requirements of the completed boat

6.1 Maximum permissible number of persons

The maximum permissible number of persons n carried shall be determined by the manufacturer and shall not exceed that calculated using the following formula:

$$n = \frac{A_i - x}{0,3}$$

where

A_i is the inboard area, in square metres;

x is the area, in square metres, of the inboard area which cannot be utilized for the accommodation of persons. (e.g. steering console, exposed fuel tank(s), etc.).

Under no circumstances, shall the value n expressed in body mass exceed the maximum load capacity (see 6.4).

ISO 6185-3:2001(E)

The value n shall always be rounded down to the nearest integer but, if the first decimal place is greater than 5, a child may be added or, if greater than 7, an adult may be added.

For calculations, the body mass of a child is defined as 37,5 kg and the body mass of an adult as 75 kg.

The data displayed on the builder's plate(s), see clause 8 e), shall include at least one adult and not more than one child.

6.2 Maximum motor power

The maximum motor power, in kilowatts, for inboard and outboard propeller-driven boats shall be determined by the manufacturer and shall not exceed that calculated using the following formula:

$$P_{\max} = 10 \times F(d) - 33$$

where

P_{\max} is the maximum motor power rating, in kilowatts, determined in accordance with ISO 8665;

$F(d)$ is the dimensional factor = $l \times b$

where

l is the overall length of the boat, in metres, from the bow to the extremity of the rear float (excluding handholds or other fittings);

b is the overall beam of the boat, in metres (excluding handholds or other fittings).

NOTE The motor maximum power rating may be increased for boats supplied with a remote steering system installed by the manufacturer as standard equipment, provided they conform to the manoeuvring test procedure specified in ISO 11592.

6.3 Static stability of the boat

6.3.1 Requirement

The boat equipped with the manufacturer's maximum rated motor(s) (see 6.2) shall not capsize when the maximum permissible number of persons recommended by the manufacturer (see 6.1) move to one side of the boat.

6.3.2 Test method

Carry out the test with the motor(s) fitted but without a fuel tank and battery. Evenly distribute the test load (persons) over the test loading area of the boat as shown in Figure 2.

The total test load m_t , in kilograms, shall be calculated using the following formula.

$$m_t = (n \times 75) + 37,5 \text{ (for a child, if applicable)}$$

where

n is the maximum permissible number of adults determined by the manufacturer (see 6.1), i.e. 75 kg for each permissible adult and 37,5 kg for a child, if applicable.

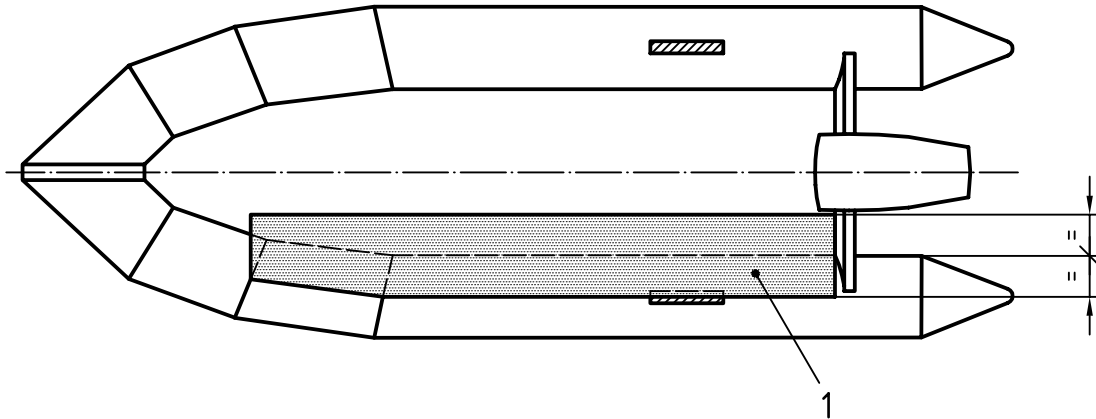

Key

1 Test loading area

Figure 2 — Typical example of boat showing test loading area

6.3.3 Stability factor (Type VIII boats only)

The stability factor of Type VIII boats shall be determined by the manufacturer using the following formula:

$$F(s) = \frac{m(l^2 \times b^3)}{1\,000}$$

where

$F(s)$ is the stability factor;

m is the total mass of the boat. See 6.4.1;

l is the overall length of the boat, in metres, see 6.2;

b is the overall beam of the boat, in metres, see 6.2.

For Type VII: $F(s) \leq 250$

For Type VIII: $F(s) > 250$

6.4 Maximum load capacity

6.4.1 Requirement

The maximum load which may be carried by the boat shall be determined by the manufacturer and shall not exceed that calculated using the following formula.

$$\text{For type VII: } m = (0,75 \times V \times 1\,000) - m_b$$

where

m is the maximum load capacity, in kilograms (total mass on board including persons, equipment, motor(s) and fuel);

V is the volume, in cubic metres, of the buoyancy of the boat;

m_b is the total mass, in kilograms, of the boat as supplied by the manufacturer [inclusive of all permanently installed equipment supplied with the boat: hull, fittings and similar items but without motor(s) and fuel]. Permanently installed engine(s) and drive systems shall also be included.

6.4.2 Test method

Calculate the maximum load capacity and compare with the manufacturer's rated value.

6.5 Design working pressures

The design working pressures shall be specified by the manufacturer for each compartment (including buoyancy chambers, keel, seats, awning, etc.) of the fully inflated boat. These pressures shall be indicated either on the appropriate compartment or in the operator's instruction booklet (or both) and, for the buoyancy chambers of the boat, on the builder's plate (see clause 8).

In order that the user may ascertain that the specified working pressure has been reached, the manufacturer shall provide appropriate equipment or a pressure gauge for this purpose. Alternatively, instructions shall be included in the operator's instruction booklet supplied (see clause 9) which will enable a sufficiently close estimate to be made.

The working pressure shall be consistently expressed in bars with psi (pounds per square inch) as an additional unit at the option of the manufacturer.

6.6 Strength of the hull

6.6.1 Requirement

The boat shall remain airtight (see 6.6.2.4) after each of the tests described in 6.6.2.

6.6.2 Test method

6.6.2.1 Test temperature

All tests shall be performed at a temperature of $20\text{ °C} \pm 3\text{ °C}$, unless specified otherwise.

6.6.2.2 Heat test (all boats types)

Assemble the boat in accordance with the manufacturer's instructions and inflate it to a pressure of 1,2 times the design working pressure. When assembled, place the boat in a heat chamber, set at 60 °C , for a period of 6 h. On completion of the test period, remove the boat from the heat chamber and allow to cool down to ambient temperature. Test the airtightness of the boat in accordance with the test specified in 6.6.2.4.

6.6.2.3 Overpressure test

Inflate each compartment of the buoyancy tube to 1,5 times the manufacturer's design working pressure for 30 min. When separate compartments have common envelope parts (for example, internal partition bulkheads), these compartments shall be individually tested with adjacent compartments deflated. No damage or rupture shall occur and the boat shall be tested for airtightness as described in 6.6.2.4.

6.6.2.4 Airtightness test

Support or insulate the boat from the floor and do not expose it to any draught of air or direct sunlight. Inflate the boat (all compartments) for 30 min to a pressure that is 20 % in excess of the manufacturer's design working pressure (see 6.5) in order to pre-stretch the boat. Then reset the pressures to the design working pressure for a further 30 min period in order to stabilize conditions. Reset the pressures to the design working pressure and record the ambient temperature and atmospheric pressure. Following a test period of 24 h, the pressure drop shall not be greater than 20 % in any compartment. Record the final ambient temperature and atmospheric pressure.

The temperature difference between the start of the test and the test readings shall not exceed ± 3 °C.

The atmospheric pressure difference between the start of the test and the test readings shall not exceed $\pm 1\%$.

For each rise or fall in ambient temperature of 1 °C, an allowance of 0,004 bar may be respectively subtracted from, or added to, the recorded boat pressure.

6.7 Safety ropes and grab handles

6.7.1 Requirement

Boats shall be equipped with a safety rope and/or handles thereby offering a firm hold to each of the permissible number of persons when occupying the seating, standing or kneeling positions provided or when outside in the water, even if the boat has capsized. All handholds shall be designed to ensure, by their nature and arrangement, that the permissible number of persons can hold them, even for a long period, without risk of injury.

There shall be no failure of the handhold assemblies when tested as described in 6.7.2.

The handholds and assemblies shall conform to the requirements for hull fittings described in 5.2. Where safety ropes and grab handles also function as manual lifting or carrying devices, they shall also conform to the requirements of 5.3.

6.7.2 Test method

Visual inspection and assessment.

Load each handle and lifeline assembly with a force of 1,5 kN for 1 mn in any direction. For a practical assessment in the water, see 7.3.2.

6.8 Residual buoyancy

6.8.1 Requirement

After failure of the largest buoyancy chamber, the residual inflated buoyancy of the hull shall be at least 50 % of the manufacturer's rated maximum load capacity (see 6.4).

6.8.2 Test method

Calculate or measure the residual buoyancy.

6.9 Manoeuvrability

6.9.1 Requirement

An inflated boat loaded to the maximum load capacity shall be capable, upon sudden deflation of any one of its compartments, of being propelled by one of its intended means. Oars may be used as paddles.

6.9.2 Test method

Propel the boat in a generally straight line for at least 50 m in calm water.

6.10 Compartmentation

The inflated buoyancy shall be contained within a number of separate buoyancy chambers (compartments). The minimum number of compartments is specified in Table 2.

Table 2 — Minimum number of compartments

Maximum motor power rating kW	Dimensional factor <i>F</i> (<i>d</i>)	Number of compartments
15 to 45	≤ 8	3
	> 8	4
> 45	≤ 8	4
	> 8	5

NOTE The dimensional factor is defined in 6.2.

The volume of each compartment, with internal partition bulkheads (see annex A) in the neutral position, shall be within the limits ± 20 % of the mean compartment volume.

Thus

$$\text{Compartment volume} = \frac{V}{N} \pm 20 \%$$

where

V is the total volume, in cubic metres, of the inflated buoyancy tube (excluding ancillary compartments, see the last paragraph of this subclause);

N is the number of buoyancy-tube compartments.

Ancillary inflatable compartments that are not permanently fixed to the hull (see 3.3) shall **not** be included in the above calculation.

6.11 Field of vision from the helm position

The field of vision from the main helm position shall conform to the requirements of ISO 11591.

6.12 Provision for (a) liferaft(s) (Type VIII boats only)

There shall be provision made for (a) liferaft(s) to be stowed on Type VIII boats that can carry the maximum permissible number of persons. If the liferaft is a rigid canister type, it shall be mounted on the deck, ready for use. If the liferaft is contained in a soft bag then it can be stowed in a compartment but readily available for use.

7 Performance test

7.1 General

Assemble the boat in accordance with the manufacturer's instructions and inflate it to the recommended working pressure.

Perform the tests in the order given in 7.2 to 7.8.

Perform tests 7.3, 7.4 and 7.5 in conditions with observed significant wave heights as shown in Table 3.

Table 3 — Sea conditions

Boat type	Dimensional factor	Observed significant wave height
	$F(d)$	mm
Type VII	≤ 8	600
	> 8	900
Type VIII	N/A	1 200
NOTE The dimensional factor is defined in 6.2.		

7.2 Drop test (RIBs only)

7.2.1 Requirement

Test the boat in the manner described in 7.2.2.

Closely examine the boat at the end of the test.

There shall be no structural failures in the form of fractures, cracks, tears, separation, etc. on any part of the hull or boat component, such as the deck or thwarts, and including any boundary interface such as floor/hull, deck/transom, buoyancy tube/hull, etc.

7.2.2 Test method

Load the boat to the maximum load capacity recommended by the manufacturer. The distribution of this load shall represent the boat fitted with motor(s) of the maximum power rating (as specified by the manufacturer) and passengers seated in their normal positions.

Consecutively drop the loaded boat from a height of 2 m (from water to lowest point of boat) into the water using three different boat attitudes:

- a) horizontal;
- b) bow down 45°;
- c) stern down 45°.

7.3 In-water performance

7.3.1 Requirement

The boat shall be equipped with any load-bearing accessories offered by the manufacturer as standard or optional equipment.

Test the boat, in the manner described in 7.3.2, fitted with motor(s) of the maximum power rating as specified by the manufacturer.

Closely examine the boat at the end of the test period.

There shall be no structural failures in the form of fractures, cracks, tears, separation, etc. on any part of the hull or boat component, such as the deck or thwarts, and including any boundary interface such as floor/hull, deck/transom, buoyancy tube/hull, etc.

There shall be no damage to any accessory or to the method of attachment to the boat.

ISO 6185-3:2001(E)

There shall be no signs of abrasion that could result in subsequent structural damage or failure.

The boat shall not overturn.

The boat shall remain reasonably dry.

The coxswain shall maintain reasonable visibility at all times.

7.3.2 Test methods

7.3.2.1 General

Use the remote steering system if it is supplied as standard equipment. If it is offered as optional equipment, carry out the test using both tiller and remote steering systems consecutively.

Use the coxswain and crew-member seating systems if they are supplied as standard or optional equipment.

7.3.2.2 Testing — Lightly loaded

Embark a coxswain only. The total period of test shall be not less than 45 min with the motor controls set to develop maximum forward thrust.

Head the boat directly upwind and then successively downwind on courses of approximately 45° separation (see Figure 3). This will give a minimum of at least five separate courses encountering a head-on, bowquarter, beam, sternquarter and following sea condition. Turn the boat sharply towards the end of each course to port and starboard (see Figure 3).

7.3.2.3 Testing — Fully loaded

Repeat the test described in 7.3.3.2 but with the boat uniformly loaded with the maximum load capacity recommended by the manufacturer (see 6.4). The load shall include the manufacturer's maximum permissible number of persons (see 6.1).

All handholds shall be clearly seen to have satisfied the requirements of 6.7.1.

All seating and attachment systems shall be clearly seen to have satisfied the requirements of 5.11.

7.4 Strength of the towing device

7.4.1 Requirement

When the boat is closely examined at the end of the test period, there shall be no structural failures on any part of the hull or boat component, such as the deck or thwarts, and including any boundary interface such as floor/hull.

During the test, there shall be no tendency for the bow to submerge or to lift in a manner likely to submerge the motor or overturn the boat.

7.4.2 Test method

Embark the maximum permissible number of persons recommended by the manufacturer (see 6.1).

Tow the boat by its designated towing point (see 5.10) at a speed of not less than 4 kn with a towline of length equal to $3 \times$ boat length ($\pm 15\%$).

Carry out towing manoeuvres for not less than 15 min.

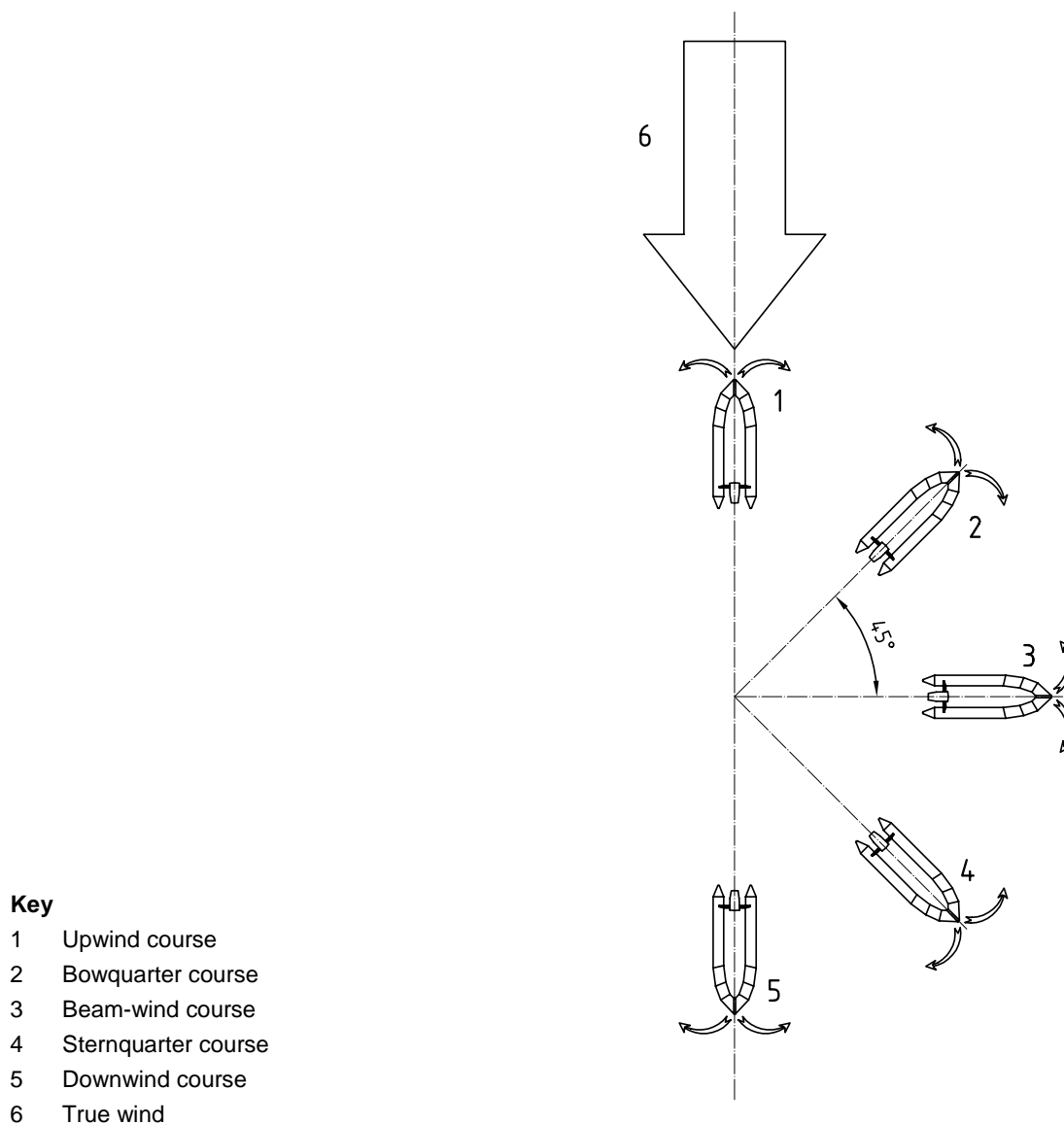
**Key**

- 1 Upwind course
- 2 Bowquarter course
- 3 Beam-wind course
- 4 Sternquarter course
- 5 Downwind course
- 6 True wind

Figure 3 — In-water performance test

7.5 Rowing test (where applicable, see 5.5)

Row the boat for a distance of not less than 300 m in both the lightly loaded condition (see 7.3.3.2) and the fully loaded condition (see 7.3.3.3).

Examine the rowlock system during and on completion of the test, and measure the unrestricted movement of the oars.

7.6 Watertightness test (not applicable to open floor, self-bailing craft)

7.6.1 Requirement

Closely examine the boat at the end of the test.

There shall be no evidence of water within the boat.

7.6.2 Test method

Ensure that there is no water within the boat. Load the boat to the maximum load capacity recommended by the manufacturer. The distribution of this load shall represent the boat fitted with motor(s) of the maximum power rating (as specified by the manufacturer) and passengers seated in their normal positions.

Allow the boat to remain static in the water for 20 min.

7.7 Manoeuvring-speed test

RIB's capable of a top speed of 30 kn or more, which are supplied with a remote steering system, installed by the manufacturer as standard equipment, shall conform to the manoeuvring-test procedure specified in ISO 11592.

7.8 Bailing test (Type VIII boats only)

7.8.1 Requirement

Test the boat in the manner described in 7.8.2.

Closely examine the boat at the end of the test.

The deck area shall be substantially free of residual water.

7.8.2 Test method

Ensure that there is no water within the boat. Load the boat to the maximum load capacity recommended by the manufacturer. The distribution of this load shall represent the boat fitted with motor(s) of the maximum power rating (as specified by the manufacturer) and passengers seated in their normal positions. Close any deck drains and scuppers while filling. Fill the deck areas with water until it starts to flow out overboard. Evacuate the water from the flooded deck areas in less than 3 min by opening the deck drains and scuppers, and, if necessary, by the forward motion of the boat or by other means without using loose equipment or an electric bilge pump.

8 Builder's plate(s)

The craft shall be equipped with one or two clearly and indelibly printed or engraved plates displaying all the relevant data listed below.

- a) Number of this part of ISO 6185 and type(s) to which the craft conforms.
- b) Name of manufacturer or importer and country of origin.
- c) Serial number and date of manufacture and type or model number. It is recommended to use the Hull Identification Number (HIN) coding system as detailed in ISO 10087.
- d) Maximum motor power, in kilowatts (shown by symbol).
- e) Maximum number of persons (shown by symbol).
- f) Maximum load capacity³⁾ (shown by symbol).
- g) Recommended working pressure (shown by symbol).

³⁾ For manufacturers who wish to show more than the maximum load capacity for a boat that falls into more than one Boat Design Category (European Directive 94/25/EC), they may show this on the Builder's plate.

Additional data may be supplied at the option of the manufacturer (maximum mass of motor(s), etc.).

Where the HIN coding system is used, the data specified in c) need not be on the builder's plate.

For the data d) to g) inclusive, the symbols shown in Figure 4 shall be used.⁴⁾

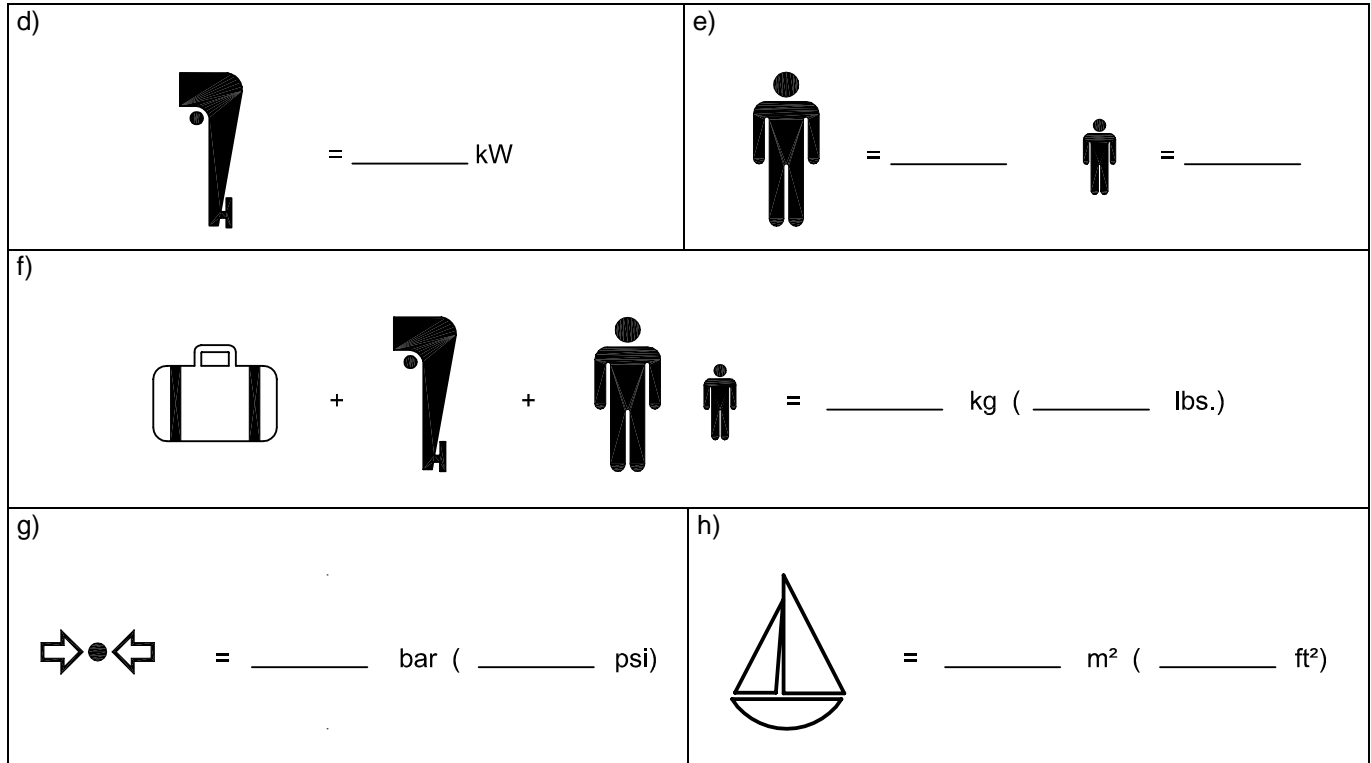

Additional units shown in brackets may be included at the option of the manufacturer.

Figure 4 — Symbols for the builder's plate

9 Operator's instructions and warning notes

Operator's instructions shall be supplied in (a) suitable language(s) and in simple terms, sufficient to enable the operator to correctly assemble, inflate and prepare the boat for use afloat, including reference to the location/fixing of seats, steering system, battery and fuel tank (where applicable).

A warning shall be provided emphasizing the dangers of not following the operator's instructions, which may detail important inflation and assembly sequences.

Guidance shall also be given on drying, storage and servicing of the boat.

Warnings and advice, where applicable, shall be given regarding the potential harmful effects of liquids such as battery acid, oil and petrol.

A warning shall be included regarding the dangers associated with uneven distribution of persons or loads in the boat.

4) Refer to ISO 7000 and ISO 11192.

The instructions shall also warn against the possibilities of natural hazards and shall contain, in a conspicuous manner, the warning

“BEWARE OF OFFSHORE WINDS AND CURRENTS”

A warning shall be included emphasizing the danger of exceeding the data given on the builder's plate(s) (see clause 8).

It is recommended to refer to ISO 10240 for the inclusion of additional information.

10 Standard equipment

The following items of equipment shall be provided by the manufacturer with each boat:

- repair outfit, suitable for repairing small punctures of limited extent, and including instructions for use;
- operator's instructions (see clause 9).

Where an inflation pump is not supplied as standard equipment, the manufacturer shall ensure that a compatible inflation pump is available.

Annex A
(informative)

General arrangement of a typical Type VII boat

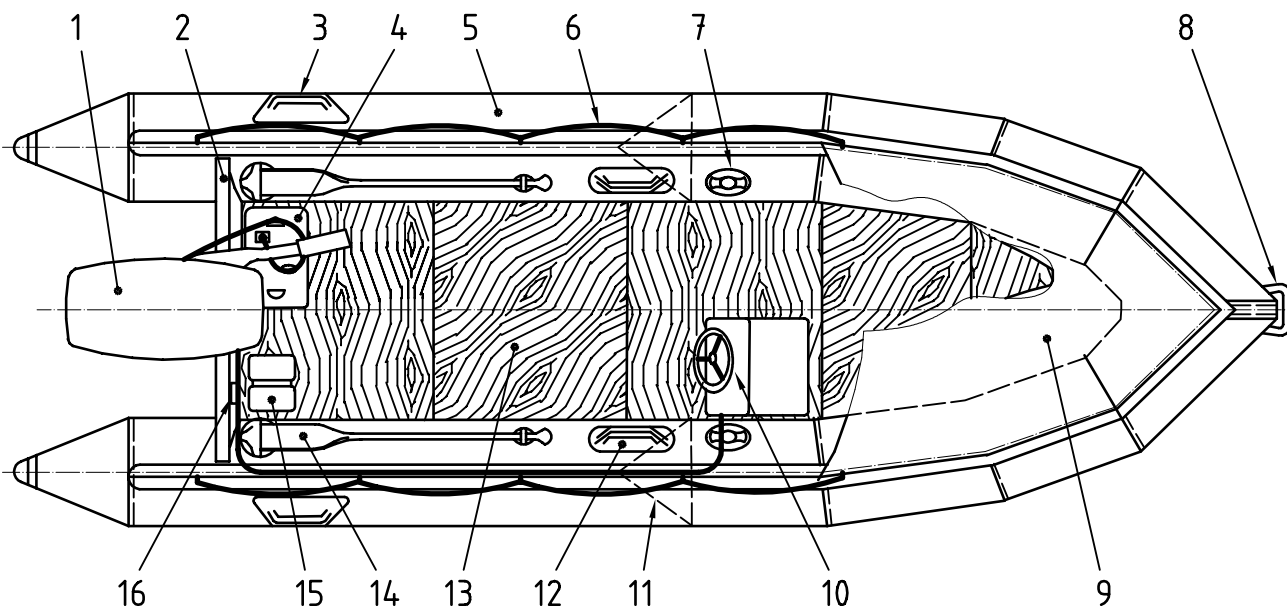

Reproduction or networking permitted without license from IHS

Key

- | | |
|--|---|
| 1 Motor | 9 Spray cover |
| 2 Transom | 10 Remote steering |
| 3 Lifting/carrying device | 11 Partition bulkhead — Example of a transverse partition |
| 4 Fuel tank | 12 Grab handle |
| 5 Buoyancy tube comprising several buoyancy chambers or compartments | 13 Inboard area |
| 6 Safety rope or lifeline | 14 Paddle or oar |
| 7 Inflation valve | 15 Battery |
| 8 Towing device | 16 Builder's plate |

Figure A.1 — Arrangement of a Type VII boat

Annex B
(informative)

General arrangement of a typical Type VIII boat

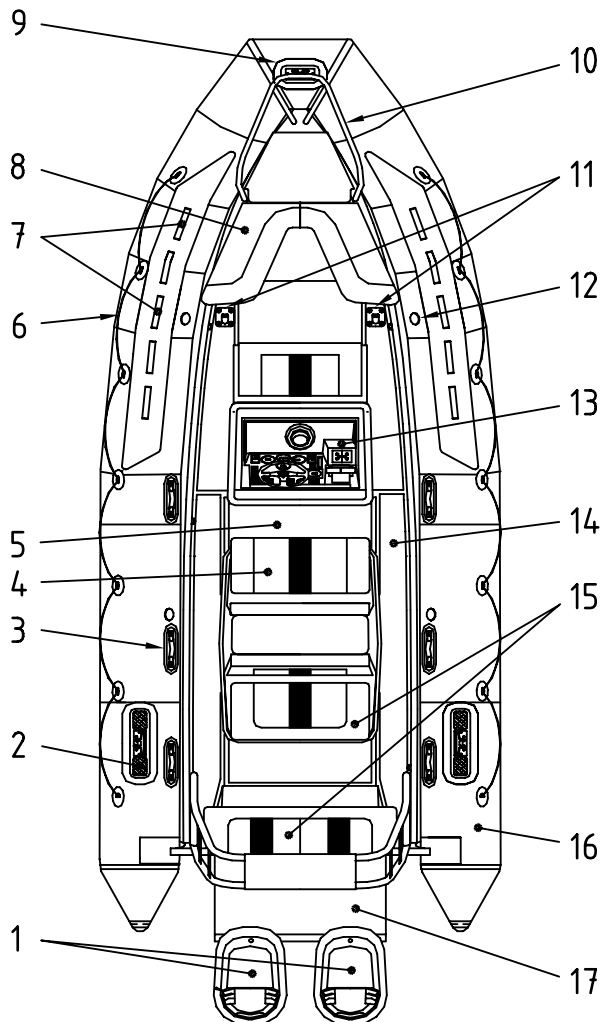

Key

- | | | | |
|---|--|----|---------------------------------------|
| 1 | Dual outboard engines on bracket extension | 10 | Bow rail |
| 2 | Mooring cleat | 11 | Lifting points |
| 3 | Passenger grab handle | 12 | Inflation valve |
| 4 | Driver and passenger seat | 13 | Steering console with instrumentation |
| 5 | Fuel tank (underdeck) | 14 | Non-skid deck on rigid hull |
| 6 | Lifelines | 15 | Passenger bench/seat |
| 7 | Passenger handles | 16 | Inflatable buoyancy tube |
| 8 | Bow seats | 17 | Stern arch |
| 9 | Mooring cleat | | |

Figure B.1 — Arrangement of a Type VIII boat

Bibliography

- [1] ISO 62:1999, *Plastics — Determination of water absorption*
- [2] ISO 10087:1995, *Small craft — Hull identification — Coding system*
- [3] ISO 10240:1995, *Small craft — Owner's manual*

ICS 47.080

Price based on 23 pages

© ISO 2001 – All rights reserved

Provided by IHS under license with ISO