**Fire protection — Automatic
sprinkler systems —**

**Part 2:
Requirements and test methods for
wet alarm valves, retard chambers
and water motor alarms**

*Protection contre l'incendie — Systèmes d'extinction automatiques du
type sprinkler —*

*Partie 2: Exigences et méthodes d'essai des soupapes d'alarme
hydrauliques, des limiteurs de surpression et des dispositifs d'alarme à
moteur hydraulique*





COPYRIGHT PROTECTED DOCUMENT

© ISO 2012

All rights reserved. Unless otherwise specified, no part of this publication may be reproduced or utilized in any form or by any means, electronic or mechanical, including photocopying and microfilm, without permission in writing from either ISO at the address below or ISO's member body in the country of the requester.

ISO copyright office
Case postale 56 • CH-1211 Geneva 20
Tel. + 41 22 749 01 11
Fax + 41 22 749 09 47
E-mail copyright@iso.org
Web www.iso.org

Published in Switzerland

Contents

	Page
Foreword	iv
1 Scope	1
2 Normative references	1
3 Terms and definitions	1
4 Requirements	3
4.1 Nominal sizes.....	3
4.2 Connections.....	3
4.3 Rated working pressure.....	3
4.4 Bodies and covers.....	3
4.5 Strength (see 6.9).....	4
4.6 Access for maintenance.....	4
4.7 Components.....	4
4.8 Leakage (see 6.8).....	5
4.9 Non-metallic components (excluding gaskets, seals and other elastomeric parts) (see 6.4 and 6.5).....	5
4.10 Sealing assembly elements (see 6.3).....	5
4.11 Clearances.....	5
4.12 Hydraulic friction loss (see 6.7).....	7
4.13 Endurance (see 6.6).....	8
4.14 Operational performance (see 6.10).....	8
4.15 Drains.....	9
4.16 Alarms (see 6.10.2).....	9
4.17 Retard device (see 6.12).....	9
4.18 Water motor alarms (see 6.11).....	10
5 Production testing and quality control	11
6 Tests	12
6.1 Samples.....	12
6.2 Spring and diaphragm test.....	12
6.3 Sealing element tests (see 4.10).....	12
6.4 Warm water aging test for non-metallic components (excluding gaskets and seals and other elastomeric parts) (see 4.9).....	14
6.5 Air aging test for non-metallic components (excluding gaskets and seals and other elastomeric parts) (see 4.9).....	14
6.6 Endurance test (see 4.13).....	15
6.7 Hydraulic friction loss test (see 4.12).....	15
6.8 Valve leakage and deformation tests (see 4.8).....	15
6.9 Body strength test (see 4.5).....	16
6.10 Operational test (see 4.14).....	16
6.11 Water motor alarm tests (see 4.16).....	17
6.12 Retard chamber tests (see 4.17).....	18
6.13 Salt mist corrosion test.....	18
7 Marking	18
8 Manufacturer's installation instructions	19
Annex A (normative) Tolerances	20

Foreword

ISO (the International Organization for Standardization) is a worldwide federation of national standards bodies (ISO member bodies). The work of preparing International Standards is normally carried out through ISO technical committees. Each member body interested in a subject for which a technical committee has been established has the right to be represented on that committee. International organizations, governmental and non-governmental, in liaison with ISO, also take part in the work. ISO collaborates closely with the International Electrotechnical Commission (IEC) on all matters of electrotechnical standardization.

International Standards are drafted in accordance with the rules given in the ISO/IEC Directives, Part 2.

The main task of technical committees is to prepare International Standards. Draft International Standards adopted by the technical committees are circulated to the member bodies for voting. Publication as an International Standard requires approval by at least 75 % of the member bodies casting a vote.

Attention is drawn to the possibility that some of the elements of this document may be the subject of patent rights. ISO shall not be held responsible for identifying any or all such patent rights.

ISO 6182-2 was prepared by Technical Committee ISO/TC 21, *Equipment for fire protection and fire fighting*, Subcommittee SC 5, *Fixed firefighting systems using water*.

This third edition cancels and replaces the second edition (ISO 6182-2:2005), which has been technically revised.

ISO 6182 consists of the following parts, under the general title *Fire protection — Automatic sprinkler systems*:

- *Part 1: Requirements and test methods for sprinklers*
- *Part 2: Requirements and test methods for wet alarm valves, retard chambers and water motor alarms*
- *Part 3: Requirements and test methods for dry pipe valves*
- *Part 4: Requirements and test methods for quick-opening devices*
- *Part 5: Requirements and test methods for deluge valves*
- *Part 6: Requirements and test methods for check valves*
- *Part 7: Requirements and test methods for early suppression fast response (ESFR) sprinklers*
- *Part 8: Requirements and test methods for pre-action dry alarm valves*
- *Part 9: Requirements and test methods for water mist nozzles*
- *Part 10: Requirements and test methods for domestic sprinklers*
- *Part 11: Requirements and test methods for pipe hangers*
- *Part 12: Requirements and test methods for grooved-end components for steel pipe systems*

Fire protection — Automatic sprinkler systems —

Part 2:

Requirements and test methods for wet alarm valves, retard chambers and water motor alarms

1 Scope

This part of ISO 6182 specifies performance, requirements, methods of test and marking requirements, for wet alarm valves, retard chambers, water motor alarms and manufacturers' specified relevant trim used in wet pipe automatic fire protection systems.

This part of ISO 6182 is not applicable to performance and test requirements for other auxiliary components or attachments to alarm valves.

2 Normative references

The following referenced documents are indispensable for the application of this document. For dated references, only the edition cited applies. For undated references, the latest edition of the referenced document (including any amendments) applies.

ISO 898-1, *Mechanical properties of fasteners made of carbon steel and alloy steel — Part 1: Bolts, screws and studs with specified property classes — Coarse thread and fine pitch thread*

ISO 898-2, *Mechanical properties of fasteners made of carbon steel and alloy steel — Part 2: Nuts with specified property classes — Coarse thread and fine pitch thread*

3 Terms and definitions

For the purposes of this document, the following terms and definitions apply.

3.1

alarm device

mechanical or electrical device which sounds an alarm upon operation of the valve

3.2

clapper

type of sealing assembly

NOTE See also 3.13.

3.3

compensator

external or internal device such as an auxiliary valve that minimizes false alarms caused by a small increase of service pressure

3.4

corrosion-resistant material

bronze, brass, Monel metal, austenitic stainless steel, or equivalent metallic or plastic material conforming with the requirements of this part of ISO 6182

NOTE Monel is an example of a suitable product available commercially. This information is given for the convenience of users of this part of ISO 6182 and does not constitute an endorsement by ISO of this product.

3.5

flow velocity

speed of water flow through a valve expressed as the equivalent water velocity through a pipe of the same nominal size as the valve

3.6

minimum opening pressure

the minimum pressure when water begins to pass through the valve

3.7

rated working pressure

maximum service pressure at which a valve or retard chamber is intended to operate

3.8

ready (set) condition

state of a valve with the sealing assembly in the closed or set position with service and system pressure applied

3.9

reinforced elastomeric element

element of clapper, clapper assembly or seat seals in a composite of an elastomeric compound with one or more other components

3.10

retard chamber

volumetric type of retard device designed to minimize false alarms caused by surges and fluctuations in sprinkler system water supplies

3.11

retard device

pneumatic, hydraulic or electric timer designed to minimize false alarms caused by surges and fluctuations in sprinkler system water supplies

3.12

retard time

difference in time for actuation of alarm devices, measured from the passage of water through the wet alarm valve port, with and without the retard chamber

3.13

sealing assembly

main movable sealing element (such as a clapper) of the valve which prevents the reverse flow of water

3.14

sealing assembly seat ring

main fixed sealing element of a valve which prevents the reverse flow of water

3.15

sensitivity

minimum rate of flow from a system outlet which will open the wet alarm valve, as indicated by satisfactory operation of alarms

3.16

service pressure

static water pressure at the inlet to a valve when the valve is in the ready condition

3.17

system pressure

static water pressure at the main outlet of a valve when the valve is in the ready condition

3.18**trim**

external equipment and pipework, excluding the main installation pipework, fitted to the valve

3.19**waste of water**

discharge of any water from the alarm port of a valve that is in the ready condition

3.20**water motor alarm**

hydraulically actuated device which provides a local audible alarm as a result of a flow through an alarm valve

3.21**wet alarm valve**

valve that permits flow of water into a wet sprinkler system, prevents the reverse flow of water and incorporates provision for actuation of an alarm under specified flow conditions

3.22**wet pipe system**

automatic fire protection system in which the piping contains water and is connected to a water supply so that water discharges upon operation of the sprinklers

4 Requirements**4.1 Nominal sizes**

The nominal size of a valve shall be the nominal diameter of the inlet and outlet connections, i.e. the pipe size for which the connections are intended. Sizes shall be 40 mm, 50 mm, 65 mm, 80 mm, 100 mm, 125 mm, 150 mm, 200 mm or 250 mm. The diameter of the waterway through the sealing assembly seat ring shall be permitted to be less than the nominal size.

4.2 Connections

4.2.1 All connections shall be designed for use at the rated working pressure of the valve.

4.2.2 The dimensions of all connections shall conform with the applicable requirements of International Standards. If International Standards are not applicable, National standards shall be permitted to be used.

4.2.3 An opening not smaller than 15 mm nominal diameter shall be provided for a water motor alarm line connection.

4.3 Rated working pressure

4.3.1 The rated working pressure shall be not less than 1,2 MPa (12 bar).

4.3.2 Inlet and outlet connections shall be permitted to be machined for lower working pressures to match installation equipment provided the valve is marked with the lower working pressure. See 7.3 f).

4.4 Bodies and covers

4.4.1 The body and cover shall be made of a material having corrosion resistance at least equivalent to cast iron.

4.4.2 Cover fasteners shall be made of steel, stainless steel, titanium, or other materials with equivalent physical and mechanical properties.

4.4.3 Non-metallic materials other than gaskets, diaphragms and seals or metals with a melting point less than 800 °C shall not form part of the valve body or cover.

4.4.4 It shall not be possible to assemble the valve with the cover plate in a position which either improperly indicates flow direction or prevents proper operation of the valve.

4.5 Strength (see 6.9)

4.5.1 An assembled valve, with the sealing assembly blocked open, shall withstand, without rupture, an internal hydrostatic pressure of four times the rated working pressure for a period of 5 min, when tested as specified in 6.9.

4.5.2 If the test in accordance with 6.9 is not done with standard production fasteners, the supplier shall provide documentation showing that the calculated design load of any standard production fastener, neglecting the force required to compress the gasket, does not exceed the minimum tensile strength specified in ISO 898-1 and ISO 898-2 when the valve is pressurized to four times the rated working pressure. The area of the application of pressure shall be calculated as follows.

- a) If a full-face gasket is used, the area of application of pressure is that extending out to a line defined by the inner edge of the bolts.
- b) If an "O"-ring seal or ring gasket is used, the area of application of force is that extending out to the centre line of the "O"-ring or gasket.

4.6 Access for maintenance

Means shall be provided to permit access to working parts and removal of the sealing assembly. Any method adopted shall permit ready maintenance by one person with a minimum of down time.

4.7 Components

4.7.1 Any component which is normally disassembled during servicing shall be designed so that it cannot be reassembled improperly without providing an external visual indication, when the valve is returned to service.

4.7.2 With the exception of valve seats, all parts intended for field replacement shall be capable of being disassembled and reassembled using tools normally employed by the trade.

4.7.3 All components shall be non-detachable during normal operation of the valve.

4.7.4 Failure of the sealing assembly diaphragms or seals shall not prevent the valve from opening.

4.7.5 Sealing surfaces of sealing assemblies, including the sealing assembly seat ring, shall have corrosion resistance equivalent to brass or bronze and have sufficient width of surface contact to withstand ordinary wear and tear, rough usage, compression stresses and damage due to pipe scale or foreign matter carried by the water.

4.7.6 Springs and diaphragms shall not fracture or rupture, when tested in accordance with 6.2.

4.7.7 There shall be no sign, on visual examination, of damage to the sealing assembly after testing for the operational requirements of 4.14 in accordance with 6.10.

4.7.8 When wide open, the sealing assembly shall bear against a definite stop. The point of contact shall be located so that impact or reaction of the water flow will not permanently twist, bend or fracture valve parts.

4.7.9 Where rotation or sliding motion is required, the part or its bearing shall be made of a corrosion resistant material. Materials lacking corrosion resistance shall be fitted with bushings, inserts or other parts made of corrosion resistant materials at those points where freedom of movement is required.

4.7.10 The sealing assembly shall close towards the seat when water flow ceases. Springs shall be permitted to ensure full and proper seating.

4.8 Leakage (see 6.8)

4.8.1 There shall be no leakage, permanent distortion or rupture of a valve when an internal pressure of twice the rated working pressure is applied for 5 min with the sealing assembly open in accordance with 6.8.1.

4.8.2 There shall be no leakage, permanent distortion or rupture of a valve at an internal pressure of twice the rated working pressure applied to the downstream side of the sealing assembly for 5 min with the upstream end vented in accordance with 6.8.2.1.

4.8.3 A valve shall not leak while being subjected to an internal hydrostatic pressure equivalent to a column of water 1,5 m high for 16 h in accordance with 6.8.2.2.

4.8.4 Sealing surfaces shall prevent leakage of water into the alarm port when the valve is tested in the ready position in accordance with 6.10.

4.9 Non-metallic components (excluding gaskets, seals and other elastomeric parts) (see 6.4 and 6.5)

Non-metallic valve parts that may affect proper valve function as defined in this part of ISO 6182 shall be subjected to the applicable ageing of its non-metallic parts, as described in 6.4 and 6.5, using separate sets of samples, as applicable. After aging, a valve shall meet the requirements of 4.8, 4.13 and 4.14.4 when tested in accordance with the applicable tests described in 6.6, 6.8 and 6.10.

4.10 Sealing assembly elements (see 6.3)

A seal made of elastomeric or other resilient materials shall not adhere to the mating surface when tested in accordance with 6.3.1. Where the same design of seat is used for more than one size of valve, it shall be permitted to only test the size with the highest stress on the seating surface.

4.11 Clearances

The requirements in Clause 4.11 are applicable to hinged, clapper-type valves only.

4.11.1 The radial clearance between a hinged sealing assembly and the inside walls in every position, except wide open, shall not be less than 12 mm for cast iron bodies and shall not be less than 6 mm if the body and sealing assembly are of cast iron or steel with corrosion protective coatings tested in accordance with 6.13, non-ferrous material, stainless steel or materials having equivalent physical, mechanical and corrosion resistant properties. See Figure 1 a).

4.11.2 There shall be a diametrical clearance of not less than 3 mm between the inner edges of a seat ring and the metal parts of a hinged sealing assembly when the valve is in the closed position. See Figure 1 b).

4.11.3 Any space in which the sealing assembly can trap debris beyond the seat shall be not less than 3 mm deep.

4.11.4 The diametrical clearance between hinge pins and their bearings shall be not less than 0,125 mm.

4.11.5 The total axial clearance between the clapper hinge and adjacent valve body bearing surfaces shall be not less than 0,25 mm. See Figure 1 c) or Figure 1 d).

4.11.6 Any reciprocating guide components, which are essential to allow a valve to open, shall have a minimum diametrical clearance of not less than 0,7 mm in that portion over which the moving component enters the fixed component and of not less than 0,05 mm in that portion of the moving component continuously in contact with the fixed component in the ready (set) position.

4.11.7 Sealing assembly guide bushings or hinge-pin bearings shall project a sufficient axial distance to maintain not less than 1,5 mm (Bushing Projection) clearance between ferrous metal parts. See Figure 1. Clearance less than 1,5 mm shall be permitted where adjacent parts are of bronze, brass, Monel metal, austenitic stainless steel, titanium, or similar corrosion resistant materials. When corrosion resistance of steel parts is provided by a protective coating, the parts shall show no visible signs of deterioration of the coating such as blistering, delamination, flaking or increased resistance to movement when tested in accordance with 6.13.

4.11.8 If provided, a compensator shall be designed such that deposits or sediment will not readily accumulate to an extent sufficient to interfere with its proper operation. There shall be sufficient clearances between the working parts to allow proper sealing of the main and any auxiliary valves.

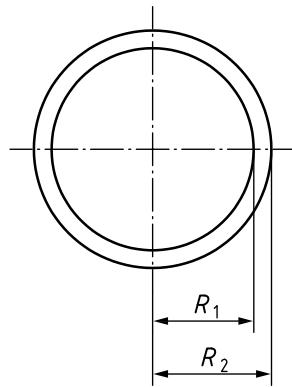

a) Radial clearance, $C_R = R_2 - R_1$

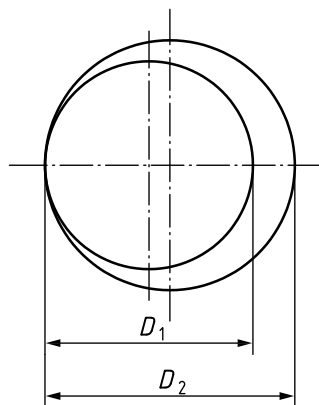

b) Diametrical clearance, $C_D = D_2 - D_1$

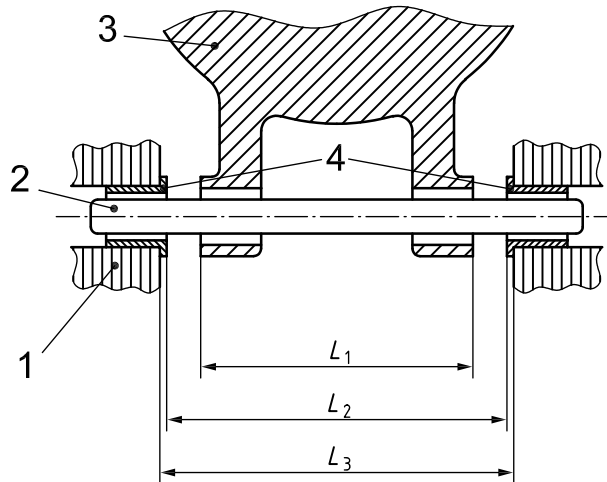

c) Total axial clearance, C_{TA} ; $C_{TA} = L_2 - L_1$; Bushing Projection = $(L_3 - L_2)/2$

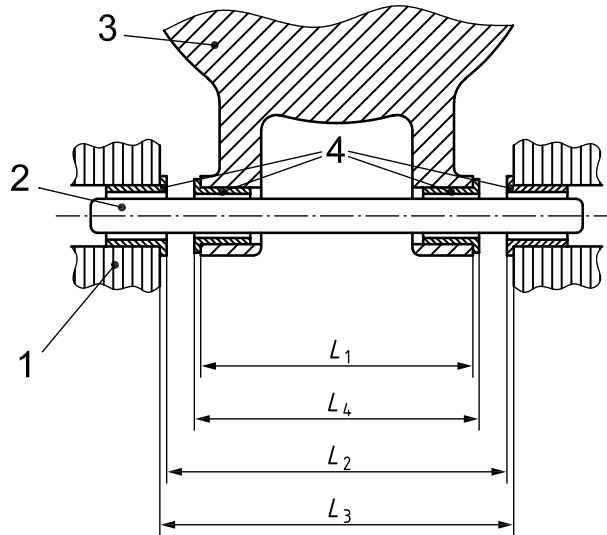

d) Total axial clearance, C_{TA} ($C_{TA} = L_2 - L_4$); Bushing projection = $(L_3 - L_2)/2 + (L_4 - L_1)/2$

Key

- 1 valve body
- 2 pin
- 3 sealing assembly
- 4 bushings

Figure 1 — Types of clearances

4.12 Hydraulic friction loss (see 6.7)

The pressure loss across the valve at the appropriate flow given in Table 1, when tested by the method of 6.7 shall not exceed the pressure loss published in the manufacturer’s installation instructions. See 8.1.

Table 1 — Required flow rates for pressure drop determination

Nominal valve size mm	Flow rate l/min
40	380

Table 1 (continued)

Nominal valve size mm	Flow rate l/min
50	590
65	1 000
80	1 510
100	2 360
125	3 680
150	5 300
200	9 920
250	14 720

4.13 Endurance (see 6.6)

The valve and its moving parts shall show no sign of distortion, cracks, loosening, separation or other sign of failure, following 30 min of water flow in accordance with 6.6.

4.14 Operational performance (see 6.10)

4.14.1 The valve shall operate correctly, without adjustment, at service pressures within the range of 0,14 MPa (1,4 bar) to the rated working pressure and flow velocities up to 5 m/s, when tested to meet the requirements of this subclause.

4.14.2 The valve shall meet the requirements of 4.14.3 and 4.14.4 when tested before and after the hydrostatic pressure test.

4.14.3 The valve with associated trim shall not signal an alarm when discharge takes place downstream from the wet alarm valve at a flow rate of 15 l/min with a service pressure of 0,14 MPa (1,4 bar) when tested in accordance with 6.10.2.2.

4.14.4 The valve with associated fittings shall signal an alarm when continuous discharge takes place downstream from the wet alarm valve at the following flow rates when tested in accordance with 6.10.2.2.

- a) 60 l/min at a service pressure of 0,14 MPa (1,4 bar);
- b) 80 l/min at a service pressure of 0,7 MPa (7 bar);
- c) 170 l/min at a service pressure of 1,2 MPa (12 bar);
- d) 170 l/min at rated working pressure, when the rated working pressure is higher than 1,2 MPa (12 bar).

4.14.5 Valves without a retard device shall initiate continuous operation of mechanical and electrical alarm devices within 15 sec from the time that the downstream valve is opened. Wet alarm valves with retard devices shall initiate continuous operation of electrical and mechanical alarm devices within a maximum of 90 sec after the wet alarm valve opens, when tested in accordance with 6.10.2.2.

4.14.6 The ratio of service pressure to system pressure shall not exceed 1,16:1 at service pressures of 0,14 MPa (1,4 bar), 0,7 MPa (7 bar), 1,2 MPa (12 bar) and rated working pressure where applicable, as measured by the opening of the sealing assembly and pressure equalization upstream and downstream of the sealing assembly when tested in accordance with 6.10.2.1.

4.14.7 The valve shall stop water flow to alarm devices on cessation of water flow downstream of the valve when tested in accordance with 6.10.2.2.

4.14.8 The valve shall transmit successive alarms without requiring resetting when tested in accordance with 6.10.2.2.

4.15 Drains

4.15.1 The valve shall be provided with a tapped opening to drain water from the valve body when the valve is installed in any position specified or recommended by the manufacturer. The minimum opening size shall be 20 mm nominal.

4.15.2 Drain openings on valves shall be permitted to be used for draining the system pipework when sized in conformance with applicable system installation standards.

4.15.3 Means shall be provided to automatically drain the piping between the valve, or any alarm shut-off valve, and any alarm device attached to the alarm line.

4.16 Alarms (see 6.10.2)

4.16.1 A valve shall actuate its associated mechanical and electrical alarm devices at flow velocities through the valve up to 5 m/s, based on nominal pipe size, at inlet supply pressures of 0,14 MPa (1,4 bar) to the rated working pressure, when tested for operation in accordance with 6.10.2.2.

4.16.2 The valve shall provide at least a pressure of 0,05 MPa (0,5 bar) at its alarm port at a service pressure of 0,14 MPa (1,4 bar) while supplying a nozzle with a k-factor of 10, when tested in accordance with 6.10.2.2.

4.17 Retard device (see 6.12)

4.17.1 Rated working pressure

The rated working pressure shall be not less than 1,2 MPa (12 bar).

4.17.2 Strength

A retard device shall withstand an internal hydrostatic pressure of twice the rated working pressure for 5 min without failure or leakage, when tested in accordance with 6.12.1.

4.17.3 Strainer

If retard chambers are to be installed in the main stream between alarm port and water motor alarm a strainer made of corrosion-resistant material shall be provided where water passages in retard devices are 6 mm or less in diameter. The maximum dimension of a hole in the strainer shall not exceed two-thirds of the diameter of the smallest orifice protected by the strainer. The total area of the openings in the strainer shall be at least 20 times the area of the openings which the strainer is designed to protect.

4.17.4 Support

A retard device shall include means for its support. If piping is used for this support, the pipe size and length shall be stated on the instruction charts provided with the wet alarm valve.

4.17.5 Connections

4.17.5.1 If retard chambers are to be installed in the main stream between alarm port and water motor alarm a tapped opening suitable for a pipe size not less than 20 mm shall be provided for connection of alarm devices, otherwise its nominal size shall be minimum 15 mm.

4.17.5.2 Any control valve fitted between a wet alarm valve and a retard device shall be of a type that can be locked or sealed in an open position. It shall also have external means for visual indication of the open and closed positions.

4.17.6 Retard chamber drain

A retard chamber shall be provided with means for automatic draining. The time for a retard chamber filled with water to its alarm level, including associated trim specified by the manufacturer, to drain to atmosphere shall not exceed 5 min when tested in accordance with 6.12.2.

4.17.7 Components

4.17.7.1 Springs and diaphragms shall not fracture or rupture during 50 000 cycles of normal operation, when tested in accordance with 6.2.

4.17.7.2 Where practical, any component which is normally disassembled during servicing shall be designed such that it cannot be reassembled improperly.

4.17.7.3 All parts intended for field replacement shall be capable of being disassembled and reassembled using tools normally employed by the trade.

4.17.7.4 After aging of the non-metallic parts, as described in 6.4, a retard device shall meet the requirements of 4.14, when tested in accordance with 6.10.

4.17.7.5 After aging of the non-metallic parts, as described in 6.5, a retard device shall meet the requirements of 4.14, when tested in accordance with 6.10.

4.18 Water motor alarms (see 6.11)

4.18.1 General

4.18.1.1 A water motor alarm shall be designed so that it can be readily installed and serviced without damage, using non-specified tools.

Subassemblies intended to be assembled in the field as a unit shall be capable of being joined together without misalignment and without requiring any of the parts to be drilled, welded, or otherwise altered except for a part required to be cut in length and/or threaded.

4.18.1.2 After aging of its non-metallic parts (excluding gaskets and seals), as described in 6.4 and 6.5, a water motor alarm shall show no cracking, warping, creep or other signs of deterioration that may preclude the proper operation of the water motor alarm.

Materials shall be resistant to the effects of temperature within the range of $-35\text{ }^{\circ}\text{C}$ to $+60\text{ }^{\circ}\text{C}$ and to the effects of sunlight excluding effects on colour.

4.18.1.3 Water motor alarm bearings shall be self-lubricating. All moving parts shall require minimal maintenance.

4.18.1.4 Any water motor having a non-metallic bearing or Pelten wheel shall be tested in an assembled condition in accordance with 6.11.4, following which it shall operate first at 0,05 MPa (0,5 bar) and then at rated working pressure for periods of 5 min each.

4.18.2 Connections

4.18.2.1 A water motor gong body shall have a threaded opening for the water supply connection of at least 20 mm nominal bore diameter. The water supply connections shall not leak or rupture when tested at twice the rated working pressure in accordance with 6.11.3.

4.18.2.2 A water motor gong body shall have a threaded opening for the water drain connection of at least 50 times the area of the water nozzle or jet.

4.18.3 Nozzles and strainers

Nozzles shall have a diameter of not less than 3 mm and shall be made of corrosion-resistant material. Sumps, strainers or other means of preventing foreign matter from entering the nozzle or jet shall be accessible for cleaning. Strainers shall be of corrosion-resistant material. The strainer shall have openings with a maximum dimension not exceeding two-thirds of the nozzle or port diameter. The total area of the openings in the strainer shall be at least 10 times the nozzle or port area.

4.18.4 Operation

A water motor and gong shall operate satisfactorily for the periods specified in Table 2, when tested in accordance with 6.11.1.

Rotation of the striker shall commence at a pressure not greater than 0,035 MPa (0,35 bar) measured at the entrance to the nozzle.

4.18.5 Bodies and covers

A cover, housing or other means shall be provided to protect the operating mechanism of a motor water alarm against weather, birds and vermin.

4.18.6 Audibility

The average of three audibility test readings at positions A, B and C shall not be less than 85 dB (A), at a pressure of 0,2 MPa (2 bar) and above at a 3 m distance, with no individual reading less than 80 dB (A). See Figure 2. The average of the three audibility test readings shall be not less than 70 dB (A) at a pressure of 0,05 MPa (0,5 bar), when tested in accordance with 6.11.2.

5 Production testing and quality control

5.1 It shall be the responsibility of the manufacturer to implement and maintain a quality control program to ensure that production continuously meets the requirements of this part of ISO 6182 in the same manner as the originally tested samples.

5.2 Every manufactured valve shall pass a hydrostatic body test for a period not less than 1 min at twice the rated working pressure without leakage.

5.3 Following the hydrostatic body test of 5.2, every manufactured valve shall pass an operation test to verify correct functioning, including flow from the alarm port.

5.4 Every manufactured valve shall withstand, without leakage at the valve seat, an internal hydrostatic pressure of twice the rated working pressure applied downstream of the clapper for a period of not less than 1 min.

6 Tests

6.1 Samples

A representative sample of each size of valve shall be subjected to the following tests.

6.2 Spring and diaphragm test

Subject the spring or diaphragm in the normal mounting to 50 000 cycles of normal operation in air or water. The components shall not be operated at a rate exceeding six cycles per minute.

For sealing assembly springs, the sealing assembly shall be rotated off the seat to a 45° angle and slowly return to the closed position. For internal bypass springs, the bypass shall be operated from the full open position to the closed position. Diaphragms shall be flexed from the normally open to the normally closed position.

6.3 Sealing element tests (see 4.10)

6.3.1 Release test

Prior to conducting this test the minimum opening pressure of the valve needs to be determined.

With the valve in a normal working position and the sealing assembly in the closed position, a hydrostatic pressure of 0,35 MPa (3,5 bar) shall be applied to the outlet end of the valve for a period of 90 days. During this period, the water temperature shall be maintained at 87 ± 2 °C by an immersion heater or other suitable heating device. Provisions shall be made to maintain the water in the inlet end of the valve at atmospheric pressure.

Upon completion of this period of exposure, the water shall be drained from the valve and the valve shall be allowed to cool to ambient temperature for at least 24 h. With the outlet end of the valve at atmospheric pressure, a hydrostatic pressure of 0,035 MPa (0,35 bar) above the minimum opening pressure shall be gradually applied to the inlet end of the valve. The sealing assembly shall move off the seat and no piece of the seal, other than colour shall adhere to the mating surface.

Where the same design of a seal is used for more than one size of valve, only a sample of the size with the highest stress on the seating surface shall be tested.

12

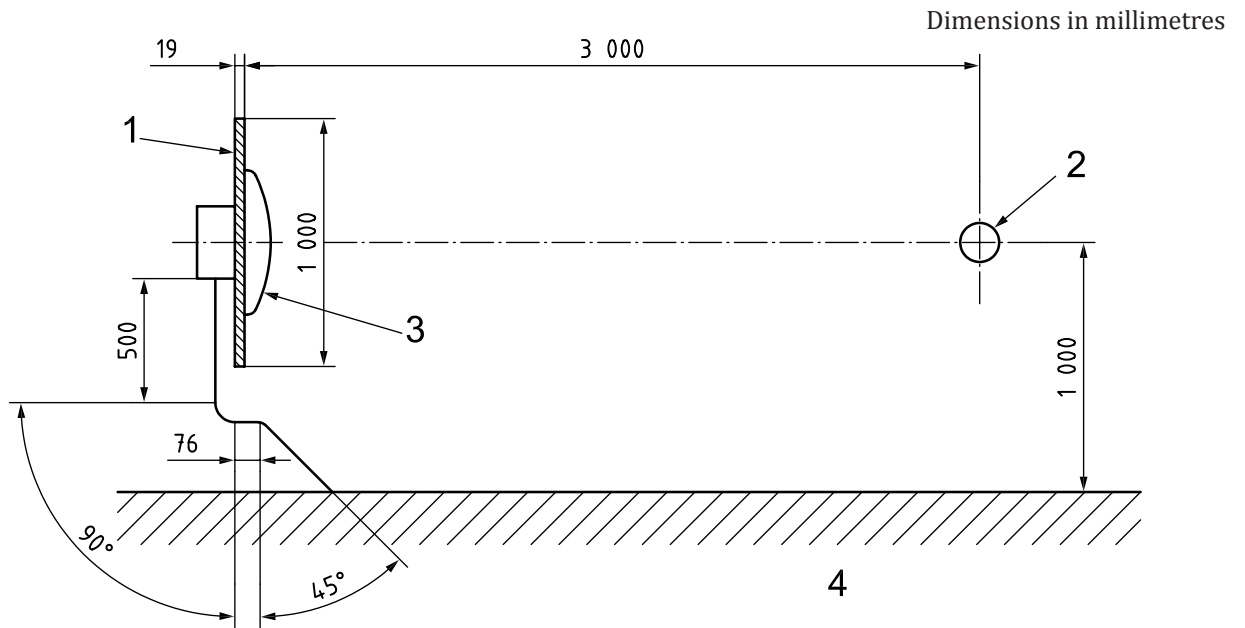

a) Side view

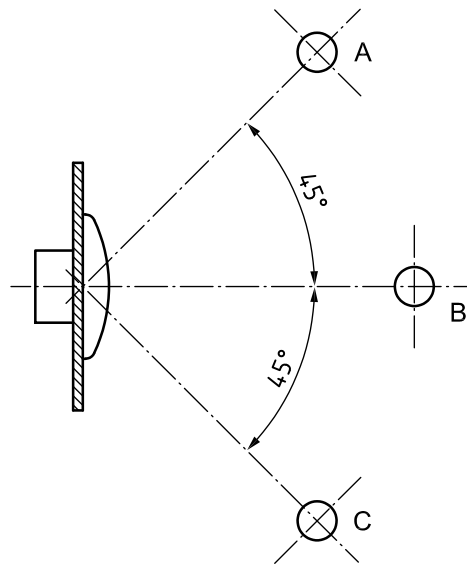

b) Top view

Key

- 1 plywood, 19 × 1 000 × 1 000
- 2 sound meter
- 3 water motor gong
- 4 paved surface
- A, B, C are test positions
- Diameter of piping to be required by manufacturer

Figure 2 — Installation for audibility test

6.4 Warm water aging test for non-metallic components (excluding gaskets and seals and other elastomeric parts) (see 4.9)

Four untested samples of each component shall be immersed in tap water at 87 ± 2 °C for 180 days.

If a material cannot withstand the temperature indicated without excessive softening, distortion, or deterioration, a water aging test shall be conducted at a lower temperature, but not less than 70 °C, for a longer period of time. The duration of exposure shall be calculated from Formula (1):

$$t = 74\,857 e^{-0,069\,3T} \quad (1)$$

where

- t is the exposure duration, expressed in days;
- e is the base of natural logarithms (= 2,718 3);
- T is the test temperature, expressed in degrees centigrade.

NOTE This equation is based on the 10 °C rule, i.e. for every 10 °C rise, the rate of a chemical reaction is approximately doubled. When applied to plastic aging, it is assumed that the life at a temperature, T , in °C is half the life at $(T - 10)$ °C.

The samples shall be removed from the water and allowed to cool to room temperature for examination for a minimum of 24 h. The components shall be examined for cracking, warping, creep, or other signs of deterioration which would preclude the proper operation of the device. The parts are then to be assembled into valves and shall comply with the requirements of 4.8.1 and 4.14, when tested in accordance with 6.8 and 6.10.

6.5 Air aging test for non-metallic components (excluding gaskets and seals and other elastomeric parts) (see 4.9)

Four untested samples of each component shall be aged in an air oven at 120 ± 2 °C for 180 days. The samples shall be tested in contact with the mating materials under stresses comparable to the intended use at rated working pressure. The components shall be supported so that they do not touch each other or the sides of the oven.

If a material cannot withstand the temperature indicated without excessive softening, distortion, or deterioration, a water aging test shall be conducted at a lower temperature, but not less than 70 °C, for a longer period of time. The duration of exposure shall be calculated from Formula (2):

$$t = 737\,000 e^{-0,069\,3T} \quad (2)$$

where

- t is the exposure duration, expressed in days;
- e is the base of natural logarithms (= 2,718 3);
- T is the test temperature, expressed in degrees centigrade.

NOTE This equation is based on the 10 °C rule, i.e. for every 10 °C rise, the rate of a chemical reaction is approximately doubled. When applied to plastic aging, it is assumed that the life at a temperature, T , in °C is half the life at $(T - 10)$ °C.

The samples shall be removed from the oven and shall be allowed to cool to room temperature for at least 24 h. All post-exposure tests shall be conducted within 72 h. The components shall be examined for cracking, warping, creep, or other signs of deterioration which would preclude the proper operation

of the device. The parts are then to be assembled into valves and comply with the requirements of 4.8.1 and 4.14, when tested in accordance with 6.8 and 6.10.

6.6 Endurance test (see 4.13)

Using the test apparatus described in 6.11, adjust the flow rate to the appropriate value given in Table 1, with a tolerance of %. Sustain a water flow through the valve at this rate for $(30 \begin{smallmatrix} +5 \\ 0 \end{smallmatrix})$ min. Examine the valve for compliance with the requirements of 4.14.

6.7 Hydraulic friction loss test (see 4.12)

Install the valve in a test apparatus using piping of the same nominal diameter. Use a differential pressure-measuring device accurate to ± 2 % of value.

Measure and record the differential pressure across the valve at a range of flows above and below the flows shown in Table 1. Replace the valve in the test apparatus by a section of pipe of the same nominal size and measure the differential pressure over the same range of flows. Using graphical methods, determine the pressure drops at the flows shown in Table 1. Record the hydraulic friction loss as the difference between the pressure drop across the valve and the pressure drop across the replacement pipe.

6.8 Valve leakage and deformation tests (see 4.8)

6.8.1 Body leakage test

Install the valve in a pressure test apparatus with the sealing assembly in the open position. Seal all openings in the valve body. Apply hydrostatic pressure of twice the rated working pressure for a period of 5 min and inspect the valve during this time for signs of leakage. The valve shall conform to the requirements of 4.8.1.

6.8.2 Valve leakage and deformation test

Install the valve under test with appropriate trim, including any external compensator and seal the downstream outlet connection.

6.8.2.1 Install a connector and bleed valve to enable the downstream portion of the valve to be hydrostatically pressurized. Seal all other connections on the portion of the valve downstream of the sealing assembly. Apply an internal hydrostatic pressure of twice the rated working pressure downstream of the closed sealing assembly for a period of 5 min. Place a sheet of paper under the valve. Leakage past the sealing assembly will be indicated by wetting of the paper.

Examine the alarm outlet for leakage.

6.8.2.2 Fit the valve outlet connection with an open-ended rise pipe and any trim which includes an external compensator.

With the clapper assembly in the closed position, fill the rise pipe with water to a level 1,5 m above the sealing assembly centre. Place a sheet of paper under the valve assembly. Leakage past the sealing assembly will be indicated by wetting of the paper. Test the valve in its intended position or positions of use and check for leakage after testing for 16 h.

6.8.2.3 Install the valve with a connector on the inlet side of the sealing assembly and a bleed valve on the outlet side. Seal all other openings. Apply a hydrostatic pressure of twice the rated working pressure. Examine the valve for leakage for a period of 5 min. Release the pressure and examine the internal component for leakage, permanent distortion or rupture.

6.9 Body strength test (see 4.5)

For the purpose of this test, standard production bolts, gaskets and seals may be replaced by components capable of withstanding the test pressure. The valve inlet and outlet connections and all other openings shall be sealed.

There shall be a connection for hydrostatically pressurizing the assembled sample valve at the inlet connection and a means of venting air and pressurizing fluid at the outlet connection. With the sealing assembly blocked open, the sample valve assembly shall be internally hydrostatically pressurized at four times the rated working pressure, but not less than 4,8 MPa (48 bar), for a period of 5 min. The valve shall conform to the requirements of 4.5.1.

6.10 Operational test (see 4.14)

6.10.1 General

Subject the valve to a series of operational tests at water service pressures of 0,14 MPa (1,4 bar) and from 0,2 MPa (2 bar) to the maximum rated working pressure in increments of 0,1 MPa (1 bar), using the test installation shown in the manufacturer's installation instructions.

6.10.2 Wet alarm valve installation

Install the wet alarm valve in accordance with the manufacturer's installation instructions. This includes an alarm line shut-off valve, alarm line drain and mechanical and electrical alarm devices recommended as suitable by the manufacturer. Additionally, a control valve and a shutoff valve are installed downstream of the wet alarm valve.

Before beginning the test program, clean sealing assembly seats and seat rings and all other operating parts. Seat the main sealing assembly member. Bolt the cover plate in place. Fill the valve with water and equalize upstream and downstream pressures. Fully open the main water supply valve and check for leakage into the alarm port.

Use the alarm devices to determine that the operational requirements of 4.16 are satisfied. Examine the wet alarm valve after completion of the tests for damage to the sealing element.

6.10.2.1 Ratio test

Apply a service pressure $(0,14 \pm 0,0028)$ MPa $[(1,4 \pm 0,028)$ bar]. Release a small flow of water from the downstream side of the wet alarm valve and record the maximum achieved differential pressure to an accuracy of ± 2 %. This is indicated by the maximum value of differential pressure obtained just before the valve opens.

Calculate the ratio, R_p , as given in Formula (3):

$$R_p = p_s / (p_s - \Delta p_{\max}) \quad (3)$$

where

p_s is the service pressure;

Δp is the maximum differential pressure.

Repeat the test at service pressures of 0,7 MPa (7 bar), 1,2 MPa (12 bar) and rated working pressure, where applicable. The valve shall conform to the requirements of 4.14.6.

6.10.2.2 Alarm and sensitivity test

Fully drain the trim piping before each test and check the drain for any signs of waste of water immediately before each test run.

Adjust the test apparatus control valve to provide a flow rate of 15 l/min at a service pressure of 0,14 MPa (1,4 bar). Check that the alarm is not operating. Where non-sprinkler devices are connected to the sprinkler piping that have a flow rate below 15 l/min and require an alarm to be signalled, the testing flow rate shall be specified by the manufacturer.

Do not manually reset the valve during the following tests.

Adjust the control valve to give a flow rate of 60 l/min. Close the downstream shutoff valve. Then open the downstream shutoff valve and time the period between the first appearance of water from the drain and continuous operation of the mechanical and electrical alarm devices. Record the pressure at the gauge monitoring the alarm line pressure when the alarm begins. Close the downstream shutoff valve and verify that the water flow to the audible alarm devices ceases. Repeat the test at flows and service pressures of 80 l/min at 0,7 MPa (7 bar), at 170 l/min at 1,2 MPa (12 bar), and at 170 l/min at rated working pressure, where applicable.

Conduct an additional test to verify alarm function at a flow rate of 10 % in excess of the value given in Table 1 with a downstream pressure not exceeding 0,4 MPa (4 bar).

6.11 Water motor alarm tests (see 4.16)

6.11.1 Durability

Carry out continuous endurance tests at the pressures, for the times and in the sequence shown in Table 2.

Table 2 — Durability

Sequence	Duration	Operating pressure at water motor inlet
1	5 min	Rated working pressure
2	50 h	0,3 times the rated working pressure

6.11.2 Audibility

Using the test arrangement in the manufacturer's installation instructions, carry out audibility tests at positions A, B and C in Figure 2 under free field conditions at pressures of 0,05 MPa (0,5 bar), 0,2 MPa (2 bar), 0,3 MPa (3 bar) and 1,0 MPa (10 bar).

6.11.3 Strength of inlet connection

Install a short length of threaded pipe to the water motor alarm inlet connection. Seal the nozzle or jet. Pressurize the connection through the pipe to twice the rated working pressure for a period of 5 min.

6.11.4 Water resistance

Immerse a water motor alarm in tap water at 40 °C for 30 days. After completion of the 30 days of immersion, test the complete water motor alarm for satisfactory operation for 5 min, first at 0,05 MPa (0,5 bar) and then at rated working pressure.

6.12 Retard chamber tests (see 4.17)

6.12.1 Strength

Install a pressure gauge to the retarded chamber alarm line outlet connection, and seal all other connections. Pressurize at the inlet connection to an internal hydrostatic pressure of twice the rated working pressure, measured at the pressure gauge, or a period of 5 min.

6.12.2 Drainage

Fill the retard chamber with water. Allow the water to drain to atmosphere, measuring and recording the time for complete drainage.

6.13 Salt mist corrosion test

6.13.1 Reagents

6.13.1.1 Sodium chloride solution, consisting of (20 ± 1) % by weight sodium chloride in distilled water, pH between 6,5 and 7,2 and having a density between 1,126 g/ml and 1,157 g/ml at (35 ± 2) °C.

6.13.2 Apparatus

6.13.2.1 Fog chamber, of minimum volume 0,43 m³, fitted with a recirculating reservoir and aspirating nozzles to deliver a salt spray, and means for sampling and controlling the atmosphere in the chamber.

6.13.3 Procedure

Remove the cover (if fitted) from the alarm valve. Support the alarm valve and alarm valve cover in the fog chamber in such a way that solution does not collect in any cavities and expose them to a salt spray by supplying the sodium chloride solution through the nozzles at a pressure of between 0,07 MPa and 0,17 MPa (0,7 bar and 1,7 bar), while maintaining the temperature in the exposure zone at (35 ± 2) °C. Ensure that solution running off the component parts under test is collected and not returned to the reservoir for recirculation.

The cover may be omitted from the test if none of the sealing assembly bushings, bearings or their clearances are associated with the cover.

Collect salt mist from at least two points in the exposure zone and measure the rate of application and the salt concentration. Ensure, for each 80 cm² of collection area, a collection rate of 1 ml/h to 2 ml/h over a period of (16) h.

Expose the component parts for a period of (10) days. After exposure, remove the alarm valve and cover (if under test) from the fog chamber and allow to dry for $(7^{+0,25}_0)$ days at a temperature not exceeding 35 °C and at a relative humidity not greater than 70 %. After the drying period, examine the corrosion protected steel parts for visible signs of deterioration of the coating such as blistering, delamination, flaking or increased resistance to movement.

7 Marking

7.1 Wet alarm valves, retard chambers and water motor alarms shall be marked either directly on the body with raised or depressed cast letters or on a permanent metal label attached mechanically (such as with rivets or screws). Metal labels shall be made of corrosion resistant material.

7.2 Cast body markings shall be in letters and figures at least 9,5 mm high. The height of the marking may be reduced to 5 mm for 50 mm and smaller valves. Cast body letters and figures shall be raised or depressed by at least 0,75 mm.

Letters on an etched or stamped permanent label shall be a minimum of 2 mm high.

7.3 Wet alarm valves shall be marked with the following:

- a) name or trade mark of the manufacturer or vendor;
- b) distinctive model number, catalogue designation or an equivalent marking;
- c) name of the device, such as “wet alarm valve”;
- d) an indication of flow direction;
- e) nominal size;
- f) maximum working pressure in MPa (or bar); if inlet and/or outlet connections are machined for lower working pressures as in 4.3.2, the lower pressure limit shall be marked;
- g) serial number or year of manufacture; wet alarm valves produced in the last three months of a calendar year may be marked with the following year as the date of manufacture; wet alarm valves produced in the first six months of a calendar year may be marked with the previous year as the date of manufacture;
- h) mounting position, if limited to vertical or horizontal position;
- i) factory of origin, if manufactured at two or more factories;

7.4 Retard chambers and water motor alarms shall be marked with the following:

- a) name or trade mark of the manufacturer or vendor;
- b) distinctive model number, catalogue designation or an equivalent marking;
- c) name of the device, such as “retard chamber” or “water motor alarm”;
- d) factory of origin, if manufactured at two or more factories;
- e) indication of flow direction (if applicable);
- f) rated current and voltage (if applicable);
- g) working pressure (if closed device).

8 Manufacturer’s installation instructions

8.1 A copy of the manufacturer’s installation instructions shall be supplied with each wet alarm valve. The chart shall include an illustration showing the valve trim function, cross-section assembly views to explain the valve operation, and friction loss value (e.g. in the form of the equivalent lengths of pipe).

8.2 The instruction chart shall include recommendations for care and maintenance.

Annex A (normative)

Tolerances

Unless otherwise stated, the tolerances given in Table A.1 shall apply.

Table A.1 — Tolerances

Parameter	Tolerance	
Angle	$\pm 2^\circ$	
Length	$\pm 2\%$ of value	
Volume	$\pm 5\%$ of value	
Pressure	$\pm 3\%$ of value	
Temperature	$\pm 5\%$ of value	
Time	$\begin{matrix} +5 \\ 0 \end{matrix}$	seconds
	$\begin{matrix} +0,1 \\ 0 \end{matrix}$	minutes
	$\begin{matrix} +0,1 \\ 0 \end{matrix}$	hours
	$\begin{matrix} +0,25 \\ 0 \end{matrix}$	days

