

# INTERNATIONAL STANDARD

**ISO  
6154**

First edition  
1989-09-01

---

---

## **Chromium ores — Preparation of samples**

*Minerais de chrome — Preparation des échantillons*



Reference number  
ISO 6154 : 1989 (E)

## Foreword

ISO (the International Organization for Standardization) is a worldwide federation of national standards bodies (ISO member bodies). The work of preparing International Standards is normally carried out through ISO technical committees. Each member body interested in a subject for which a technical committee has been established has the right to be represented on that committee. International organizations, governmental and non-governmental, in liaison with ISO, also take part in the work. ISO collaborates closely with the International Electrotechnical Commission (IEC) on all matters of electrotechnical standardization.

Draft International Standards adopted by the technical committees are circulated to the member bodies for approval before their acceptance as International Standards by the ISO Council. They are approved in accordance with ISO procedures requiring at least 75 % approval by the member bodies voting.

International Standard ISO 6154 was prepared by Technical Committee ISO/TC 65, *Manganese and chromium ores*.

Annex A forms an integral part of this International Standard.

# Chromium ores — Preparation of samples

## 1 Scope

This International Standard specifies the methods of preparing samples of chromium ores for determining the chemical composition and moisture content of a consignment. The methods are applicable to all chromium ores, whether natural or processed.

## 2 Normative references

The following standards contain provisions which, through reference in this text, constitute provisions of this International Standard. At the time of publication, the editions indicated were valid. All standards are subject to revision, and parties to agreements based on this International Standard are encouraged to investigate the possibility of applying the most recent editions of the standards listed below. Members of IEC and ISO maintain registers of currently valid International Standards.

ISO 565 : 1983, *Test sieves — Woven metal wire cloth, perforated plate and electroformed sheet — Nominal sizes of openings.*

ISO 6153 : 1989, *Chromium ores — Increment sampling.*

## 3 Definitions

For the purposes of this International Standard, the following definitions apply.

**3.1 lot :** A definite quantity of an ore, processed or produced under conditions which are presumed uniform.

**3.2 consignment :** A quantity of an ore delivered at one time. The consignment may consist of one or more lots or parts of lots.

**3.3 increment :**

- (1) A quantity of an ore taken by a sampling device at one time from a consignment.
- (2) A quantity taken by the increment division method.

**3.4 sub-sample :**

- (1) A quantity of an ore consisting of two or more increments taken from a consignment.
- (2) An aggregation of two or more increments each of which has been optionally crushed and/or optionally divided as necessary.

**3.5 gross sample :**

- (1) The quantity of an ore consisting of all the increments taken from a consignment.
- (2) An aggregation of all the increments or all the sub-samples each of which has been optionally crushed and/or optionally divided as necessary.

**3.6 divided sample :** A sample obtained by a method of division.

**3.7 test sample :** Any sample for the determination of moisture content or chemical composition, which is prepared from each increment, each sub-sample, or from the gross sample in accordance with the specified method for that type of sample.

A representative part of a test sample which is actually subjected to the method mentioned above is designated "test portion". If the entire quantity of a test sample is subjected to the test, the test sample may also be called "test portion".

**3.8 moisture sample :** The sample taken for the determination of moisture content of the consignment.

**3.9 sample for chemical analysis :** The sample taken for the determination of chemical composition of the consignment.

**3.10 whole-through sieve size :** Particle size expressed by the smallest sieve aperture size through which all of a sample passes.

**3.11 sample preparation :** The process of preparing the sample for the determination of quality characteristics. It covers sample division, crushing, mixing and sometimes pre-drying and may be performed at several stages.

**3.12 sample division :** The process in sample preparation whereby the mass of a sample is reduced by partition or extraction without crushing.

**3.13 constant-mass division :** A type of division for obtaining divided samples having almost uniform mass regardless of the variation in mass of samples to be divided.

NOTE — Almost uniform mass means that the variation in mass shall be less than 20 % in terms of the coefficient of variation (CV).

**3.14 fixed-rated division :** A type of division for obtaining divided samples having such masses as to be proportional to the varied masses of samples to be divided.

**3.15 split-use of sample :** The sample is split into two or more parts, which are used individually for the determination of their two or more quality characteristics.

**3.16 multiple-use of sample :** The sample in its entirety is used for the determination of one quality characteristic, then the same sample in its entirety or part is used for the determination of other quality characteristics.

## 4 General procedures for sample preparation

The increments taken in accordance with ISO 6153 for the required determinations shall be separated into test samples according to the following general procedures :

- a) Determine whether the test sample is to be prepared from each increment, from each sub-sample or from the gross sample according to the requirements for the determination of quality characteristics.
- b) Determine whether the sample is in split-use or in multiple-use.
- c) Select the method and type of sample division at each stage.
- d) Establish the flow of sample preparation including the processes of division, crushing, mixing and pre-drying (if necessary).

Prepare the test sample according to the procedures mentioned above.

## 5 Principles of sample preparation

### 5.1 Precision of sample preparation and overall precision

The precision of sample preparation ( $\beta_D$ ) shall be within  $\pm 0,5$  % in chromium or moisture content with a 95 % probability. However, if sample preparation is carried out first on individual increments or sub-samples at an appropriate stage of the sample preparation and then those divided increments or sub-samples are combined into the gross sample, the precision of sample preparation will be further improved (see 5.1.2 and 5.1.3).

The overall precision in terms of standard deviation ( $\sigma_{SDM}$ ) for the cases where division and measurement are carried out on the gross sample, on each of the sub-samples or on each of the increments may be expressed as given in 5.1.1 to 5.1.3.

**5.1.1** When the gross sample is composed for one consignment and  $l$  determinations (chemical analyses) are carried out on the gross sample, the overall precision is given by the equation

$$\sigma_{SDM}^2 = \sigma_S^2 + \sigma_D^2 + \frac{\sigma_M^2}{l}$$

where

$\sigma_S$  is the precision of sampling in terms of standard deviation;

$\sigma_D$  is the precision of sample preparation in terms of standard deviation comprising the processes from the gross sample to the test sample;

$\sigma_M$  is the precision of measurement in terms of standard deviation.

**5.1.2** When  $k$  sub-samples, whereby each sub-sample consists of an equal number of increments, are compared and  $l$  determinations are carried out on each sub-sample, the overall precision is given by the equation

$$\sigma_{SDM}^2 = \sigma_S^2 + \frac{\sigma_D^2 + \sigma_M^2/l}{k}$$

where

$\sigma_D$  is the precision of sample preparation in terms of standard deviation comprising the processes from the sub-sample to the test sample.

**5.1.3** When  $l$  determinations are carried out on each increment, the overall precision is given by the equation

$$\sigma_{SDM}^2 = \sigma_S^2 + \frac{\sigma_D^2 + \sigma_M^2/l}{n}$$

where

$\sigma_D$  is the precision of sample preparation in terms of standard deviation covering the processes from the increment to the test sample;

$n$  is the number of increments.

### 5.2 Composition of samples

When samples are to be composed of the increments, the following shall be taken into consideration :

- a) the quality characteristics to be determined;
- b) the overall precision to be attained;
- c) the coefficient of variation (CV) in the mass of the increments taken by mass-basis sampling.

Combining of increments taken on time-basis sampling and mass-basis sampling shall incorporate the procedures specified in clause 7.

### 5.3 Division rules

In order to obtain the specified precision of sample preparation the following aspects of division shall be taken into consideration :

- a) the minimum mass of the sample after division, specified for each quality characteristic to be determined;
- b) the method and type of division to be adopted;
- c) the whole-through sieve size of the sample to be divided.

### 5.4 Methods and types of division

One or more of the following methods of sample division shall be conducted individually or jointly :

- a) manual increment division method;
- b) manual riffle division method;
- c) coning and quartering method;
- d) mechanical division method.

This International Standard shall be applied to increments or sub-samples on the basis of taking increments and division type as shown in table 1.

### 5.5 Split-use and multiple-use of sample

When a sample taken from the consignment meets the respective requirements for the determination of quality characteristics, the sample may be either in split-use or in multiple-use to obtain the test samples for moisture determination and chemical analysis.

### 5.6 Crushing and grinding

Crushing and grinding shall be conducted with a suitable crusher and grinder for the size and hardness of the ore particles.

The crusher and grinder should be purged with material from the same source.

Table 1 — Application of division method

Division of	Conditions of increment				Manual division method to be applied		Mechanical division method to be applied		
	Sampling		Number of increments composed	CV %	Constant mass division	Fixed-rate division	Constant mass division	Fixed-rate division	
	Method	Type			Increment division method	Riffle division & C/Q	Cutter chute type divider	Cutter chute type divider	Rotary cone type divider
Increment	Manual	Mass-basis		< 20	x	x	x	—	x
	Mechanical			> 20	x	—	x	—	—
		Time-basis		< 20	x	x	x	—	x
					> 20	x	—	x	—
Sub-sample	Manual	Mass-basis	Equal		x	x	x	—	x
	Mechanical				> 20	x	x	x	—
		Time-basis			Unequal	—	x	—	—
							—	x	—

C/Q : Coning & quartering method

x : Applicable

— : Not applicable

NOTE — Any of the manual division methods applies to the gross sample.

## 5.7 Mixing

By mixing the sample thoroughly, it may be made homogeneous and consequently the errors in sample division can be lessened. Mixing may be conducted either by a mechanical mixer or by hand. The mixer shall be selected to suit the sample and its particle size.

## 5.8 Pre-drying

When the sample is very wet or sticky and sample preparation cannot be carried out, the sample may be predried by air or oven-drying, below the temperature where there is likely to be a change in quality, to facilitate sample preparation.

Pre-drying in a drying-oven shall be conducted at a temperature below 105 °C.

## 5.9 Requirements for sample preparation

Sample preparation shall be carried out in such a manner that there shall be no contamination or introduction of materials other than the sample and no change in its quality. In particular, the moisture sample shall be kept in an airtight, non-absorbent container in order to avoid any change in its moisture content.

Check experiments for precision and bias shall be carried out from time to time on the sample preparation process, so that significant errors in the results caused by the process may be detected.

The mechanical installation for sample preparation shall be installed at the nearest point to the sampling facilities.

## 6 Apparatus

Provisions shall be made to prevent contamination of the apparatus.

The apparatus used in sample preparation shall be thoroughly cleaned and examined before and after use.

The following apparatus shall be provided for sample preparation :

**6.1 crushers and grinders** suitable for the size and hardness of the ore particles;

**6.2 screens and sieves** in accordance with ISO 565;

**6.3 manual and mechanical dividing apparatus** (riffle dividers, slot, radial-slot, etc.);

**6.4 drying ovens**, capable of being controlled at 105 °C ± 5 °C;

**6.5 shovels.**

## 7 Combining increments for sample preparation

The method of combining increments shall be selected according to the type of sampling employed for taking increments, i.e., whether the increments have been taken by mass-basis sampling or by time-basis sampling. Systematic sampling is classified into two types; mass-basis and time-basis. Stratified and two-stage samplings are performed on a mass-basis.

### 7.1 Combining increments taken by mass-basis sampling

#### 7.1.1 Composition of sub-samples or gross sample from increments

When the variation in mass of individual increments is less than 20 % (CV < 20 %), the increments, either as taken or after having been prepared individually by constant-mass or fixed-rate division at an appropriate stage, shall be combined into sub-samples or the gross sample.

When the variation in mass of individual increments is 20 % or over (CV ≥ 20 %), the increments as they are taken shall not be combined into sub-samples or the gross sample.

The increments prepared after having been divided individually by constant-mass division at a practical stage should be combined into sub-samples or the gross sample at an appropriate stage (see table 1). Otherwise, each increment should be prepared as a test sample to be subjected to the determination of quality characteristics.

#### 7.1.2 Composition of gross sample from sub-samples

The sub-samples composed using the method specified in 7.1.1 should, with or without division, be combined into the gross sample. When division is carried out on each sub-sample to compose the gross sample, the division shall be carried out as follows :

- a) If the sub-samples consist of an equal number of increments, constant-mass or fixed-rate division may be applied;
- b) If the sub-samples consist of different numbers of increments, only fixed-rate division shall be applied.

### 7.2 Combining increments taken by time-basis sampling

#### 7.2.1 Composition of sub-samples or the gross sample from increments

The increments as they are taken should be combined into sub-samples or the gross-sample, irrespective of the variation in the mass of the increments.

When division is carried out on each increment and the divided increments are combined into sub-samples or the gross sample, the division shall be carried out on each increment by fixed-rate division at any stage (see table 1).

### 7.2.2 Composition of the gross sample from sub-samples

The sub-samples composed according to 7.2.1 should, with or without division, be combined into the gross sample, irrespective of the variation in mass of the sub-samples.

When division is carried out on each sub-sample and the divided sub-samples are combined into the gross sample, the division shall be carried out on each sub-sample by fixed-rate division at any stage (see table 1).

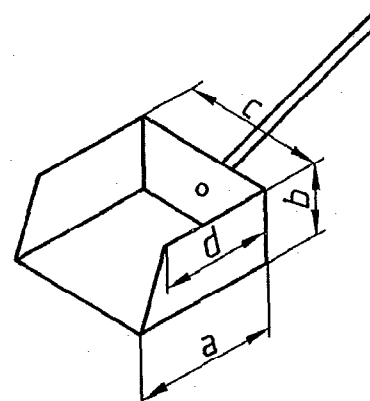

Figure 1 – Shovel for increment division

## 8 Sample division

### 8.1 Division methods

Sample division shall be carried out by the processes specified in 5.4.

### 8.2 Increment division method

The increment division method shall be conducted on samples with a whole-through sieve size less than 22,4 mm.

Depending on the particle size, select the appropriate shovel (see figure 1) as specified in table 3. If the mass of the divided sample is less than that specified in table 2, the larger shovel shall be taken.

#### 8.2.1 Mass of increment

The mass of each increment shall be as specified in table 2.

Table 2 – Whole-through sieve size of sample and minimum mass of each increment

Whole-through sieve size		Minimum mass of each increment g
Over	Up to and including	
16,0 mm	22,4 mm	600
10,0 mm	16,0 mm	400
5,0 mm	10,0 mm	250
2,80 mm	5,00 mm	150
1,00 mm	2,80 mm	80
500 µm	1,00 mm	25
250 µm	500 µm	10
	250 µm	5

Table 3 – Dimensions of shovels for increment division

Particle size mm	Dimensions of shovels mm				Approximate volume cm <sup>3</sup>
	a	b	c	d	
< 10	60	35	60	50	120
< 5	50	30	50	40	65
< 2,8 (3,0)	40	25	40	30	35
< 1	30	15	30	25	10
< 0,5	20	10	20	20	4

#### 8.2.2 Number of increments

The number of increments as given in table 4 shall be taken by the manual increment division method.

Table 4 – Number of increments to be taken by manual increment division method

Division of	Minimum number of increments
gross sample	20
sub-sample	12
increment (primary)	4

#### 8.2.3 Procedure

The sample division by the manual increment division method shall be carried out as follows :

- a) Form the sample to be divided (minus 22,4 mm) on a smooth flat plate (non-moisture absorbing) into a flat rectangle with a uniform thickness of the sample layer as specified in table 5.
- b) Arrange the rectangle in the same number of parts as the minimum number of increments specified in table 4.

c) Select an appropriate shovel as shown in figure 1, according to the whole-through sieve size. Take a shovelful of sample from each of the parts (the place of taking such an increment being selected at random in each part), and combine these shovelfuls of sample.

The shovel shall be thrust through to the bottom of the sample layer by the above procedure.

It is recommended that a bumper plate be held vertically in the material on the floor plate in front of the path of the shovel and the shovel then thrust to the bottom of the sample layer up to the bumper plate in order to collect an unbiased increment.

d) If the mass of the divided sample might become smaller than that required for subsequent testing purposes, the mass of the increment and/or the number of increments shall be increased.

Figure 2 illustrates an example of sample division for the gross sample by the manual increment division method.

**Table 5 — Whole-through sieve size, thickness of spread sample and shovel for increment division**

Whole-through sieve size mm		Thickness of spread sample for increment division mm	Shovel for increment division	
Over	Up to and including		Shovel number	Volume (approx.) ml
16,0 mm	22,4 mm	50 to 60	20 D	270
10,0 mm	16,0 mm	40 to 50	16 D	180
5,00 mm	10,0 mm	30 to 40	10 D	120
2,80 mm	5,00 mm	25 to 35	5 D	65
1,00 mm	2,80 mm	20 to 30	3 D	35
500 µm	1,00 mm	10 to 20	1 D	10
250 µm	500 µm	5 to 10	0,5 D	4
	250 µm	5 to 10	0,25 D	2

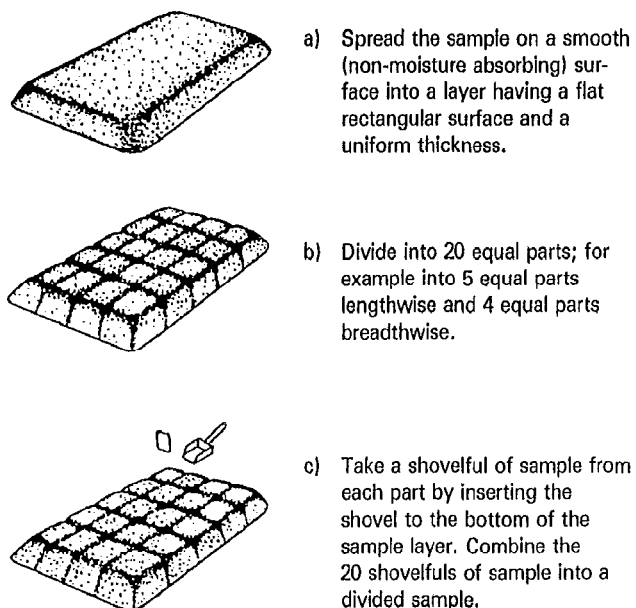

**Figure 2 — Example of manual increment division method**

**8.3 Riffle division method**

Division by riffle divider shall be conducted in the case of ores with a whole-through sieve size of less than 22,4 mm.

The riffle divider shall be selected according to the ore particle size (see table 6 and annex A).

**Table 6 — Whole-through sieve size of sample and size of riffle divider**

Whole-through sieve size mm		Riffle divider number	Opening width of riffle mm
Over	Up to and including		
16,0	22,4	50	50 ± 1
10,0	16,0	30	30 ± 1
5,00	10,0	20	20 ± 1
2,80 (3,00)	5,00	10	10 ± 0,5
	2,80 (3,00)	6	6 ± 0,5

**8.3.1 Division limit**

In dividing the moisture sample and sample for chemical analysis, the division shall be carried out according to tables 7 and 8.

**8.3.2 Procedure**

Place the sample in a container after mixing and divide it into two parts by dropping the sample uniformly, by lightly shaking the container, into the middle of the riffles.

One of the two parts obtained shall be taken at random and not divided further than the mass specified in tables 7 and 8.

Care shall be taken not to leave any material retained in the slots of the riffle divider.

**Table 7 — Minimum mass of divided gross sample for moisture determination and/or chemical analysis by fixed-rate division**

Whole-through sieve size		Minimum mass of divided sample kg
Over	Up to and including	
16,0 mm	22,4 mm	250
10,0 mm	16,0 mm	150
5,00 mm	10,0 mm	50
2,80 mm	5,00 mm	25
1,00 mm	2,80 mm	15
500 µm	1,00 mm	10
250 µm	500 µm	5
	250 µm	0,5



**Table 8 — Minimum mass of divided individual increment or sub-sample for moisture determination and/or chemical analysis by fixed-rate division**

Whole-through sieve size		Minimum mass of divided sample kg
Over	Up to and including	
16,0 mm	22,4 mm	50
10,0 mm	16,0 mm	30
5,00 mm	10,0 mm	10
2,80 mm	5,00 mm	5
1,00 mm	2,80 mm	3
500 µm	1,00 mm	2
250 µm	500 µm	1
	250 µm	0,1

#### 8.4 Coning and quartering method

The coning and quartering method may be conducted on ores of any particle size.

##### 8.4.1 Procedure

Mix the sample on a plate by heaping into a cone. Form the conical heap by depositing each shovelful on top of the preceding one, taking care to place it on the apex of the cone.

Form a new cone twice in a similar way, taking care to work steadily around the previous one until it is all transferred. Flatten the third cone into the shape of a disc of uniform thickness and diameter.

Cut the flattened heap into quarters with a special spider. Completely remove and reject two diagonally opposite sectors and combine and crush the remaining two according to tables 7 and 8.

##### 8.4.2 Division limit

In dividing the moisture sample and sample for chemical analysis, the division shall be carried out according to tables 7 and 8.

#### 8.5 Mechanical dividing method

Mechanical division shall be conducted by an adequate mechanical divider subject to the conditions of the sample to be divided.

When the sample is divided by a mechanical dividing apparatus, the apparatus shall be checked in advance to confirm that there is no bias.

The cutting aperture of divider shall be at least three times the whole-through sieve size of sample to be divided.

##### 8.5.1 Mechanical dividers

Examples of dividers are given below :

- cutter-chute type divider;
- slotted belt type divider;
- rotary cutter chute type divider;
- rotary cone type divider.

##### 8.5.2 Constant-mass division

As a rule, mechanical increment division apparatus (e.g. cutter type divider) is used for constant-mass division. If the divider satisfies the requirements given in a) to c) below, the division of the moisture sample and sample for chemical analysis may be carried out by constant-mass division.

- The mass of cut shall be uniform. In order to realize this, the flow of sample to be divided shall be uniform and the cutting aperture and speed of the cutter shall be constant.

NOTE — A combination of variable feed rate of sample to be divided and variable speed cutter may be considered.

- The interval between taking cuts shall be made variable according to the mass of the sample to be divided.

- In order to avoid bias, it is necessary to have a random start to take the first cut for each sample to be divided within the first interval.

- In the case of constant-mass division, minimum numbers of cuts and the minimum mass of one cut of the sample to be divided shall be taken according to table 9.

**Table 9 — Division limit for constant-mass division by mechanical increment division apparatus**

Whole-through sieve size mm		Cutting aperture	Minimum mass of 1 cut, kg	Minimum number of cuts		
Over	Up to and including			Gross sample	Sub- sample	Increment
16,0	22,4	80	0,6	20	12	4
10,0	16,0	70	0,4	20	12	4
5,00	10,0	60	0,25	20	12	4
2,80	5,00	50	0,15	20	12	4
1,00	2,80	40	0,08	20	12	4
	1,00	30	0,025	20	12	4

### 8.5.3 Fixed-rate division

Fixed-rate division is obtained with apparatus other than that used for mechanical increment division (e.g. with rotary cone type divider, mechanically charged riffle divider etc.). However, when the increments are taken by time-basis sampling, fixed-rate division may be applied using mechanical increment division apparatus.

### 8.5.4 Division limit

Division by mechanical dividers shall be conducted in the case of ore with particle size minus 22,4 mm.

#### 8.5.4.1 Gross sample

When the gross sample is divided, the division shall be carried out according to table 7.

The gross sample shall not be divided further than the specified mass corresponding to the whole-through sieve size.

#### 8.5.4.2 Increment or sub-sample

When an individual increment or sub-sample is divided, the division shall be carried out according to table 8.

The sample shall not be divided further than the specified mass corresponding to the whole-through sieve size.

## 9 Sample preparation

### 9.1 Preparation of moisture sample

9.1.1 The test sample for moisture determination shall be prepared from each increment, each sub-sample or the gross sample.

When increments are taken by time-basis sampling, the test sample shall be prepared specially from each sub-sample or the gross sample. In this case, each sub-sample and its corresponding mass or part of a consignment shall be clearly shown.

9.1.2 The test sample for moisture determination may be prepared by splitting the sample for chemical analysis at the stage permitted, such as minus 22,4 mm or minus 10,0 mm in particle size.

9.1.3 A moisture sample having a whole-through sieve size of plus 22,4 mm shall be crushed to minus 22,4 mm or minus 10,0 mm particle size.

A test portion of 5 kg minimum for minus 22,4 mm, or 1 kg minimum for minus 10,0 mm shall be obtained from the test sample by any of the methods specified in 5.4, irrespective of the division limit.

9.1.4 Moisture determination shall be conducted immediately after the sample preparation.

When immediate determination is impossible, the test sample shall be packed tightly in a moisture-proof container and kept in an environment which has approximately constant temperature and humidity.

9.1.5 When the gross sample is to be subjected to the determination of moisture content, one test sample for moisture determination shall be prepared from the gross sample and then four test portions shall be taken from that test sample.

When each sub-sample is to be subjected to moisture determination, one test sample shall be prepared from each sub-sample and then the number of test portions given in table 10 shall be taken from each test sample, depending on the number of sub-samples per consignment.

Table 10 — Number of test portions per test sample

Number of sub-samples per consignment	Number of test portions to be taken per test sample
2	4
3 to 7	2 min.
8 and over	1 min.

When moisture measurement is to be carried out on each increment, at least one test portion per increment shall be prepared.

9.1.6 When a consignment is comparatively large, the increments taken consecutively from the consignment shall be combined into a number of sub-samples for moisture determination as indicated in table 11.

When it takes a long time for loading or unloading of a consignment, the said increments shall be combined into a sub-sample at least every 8 h until the handling operation is completed.

Table 11 — Minimum number of sub-samples per consignment for moisture determination

Mass of consignment t		Min. number of sub-samples per consignment	Number of test portions	Number of tests
Over	Up to and including			
30 000		5	2	10
15 000	30 000	4	2	8
5 000	15 000	2	4	8
	5 000	1	4	4

### 9.2 Preparation of samples for chemical analysis

9.2.1 Each increment, each sub-sample or the gross sample shall be ground to minus 160 µm in accordance with the agreed sample preparation process.

Several types of grinders may be used to grind the sample for chemical analysis (e.g. shatter-box or vibrating ring grinder or other suitable types of mill).

When the division is carried out on an individual increment or sub-sample before the formation of a gross sample, the gross sample shall be obtained at some state of division by combining quantities proportional to the mass of the individual increment or sub-sample.

**9.2.2** From this sample, four sets of test samples for chemical analysis each of mass 50 g or more, shall be prepared by the increment division method. Three of the samples are intended for the seller, the purchaser and arbitration, and one is to be held in reserve. The reserved sample shall be retained for 6 months. The mass of the samples for chemical analysis may be increased by agreement between the interested parties.

**9.2.3** The test samples for chemical analysis shall be placed in suitable containers with the label marked in accordance with clause 10 and sent for chemical analysis. An example of the sample preparation process is shown in figure 3.

## 10 Marking of analysis sample

The following information shall be shown on the label and on a card placed in the container with an analysis sample :

- a) name and address of the seller;
- b) name and address of the purchaser;
- c) number and date of the certificate;
- d) name of consignment (name of ship, train, etc.);
- e) mass, in tonnes, of the consignment;
- f) type and quality characteristics of the ore;
- g) place and date of sampling;
- h) any other item (if necessary).

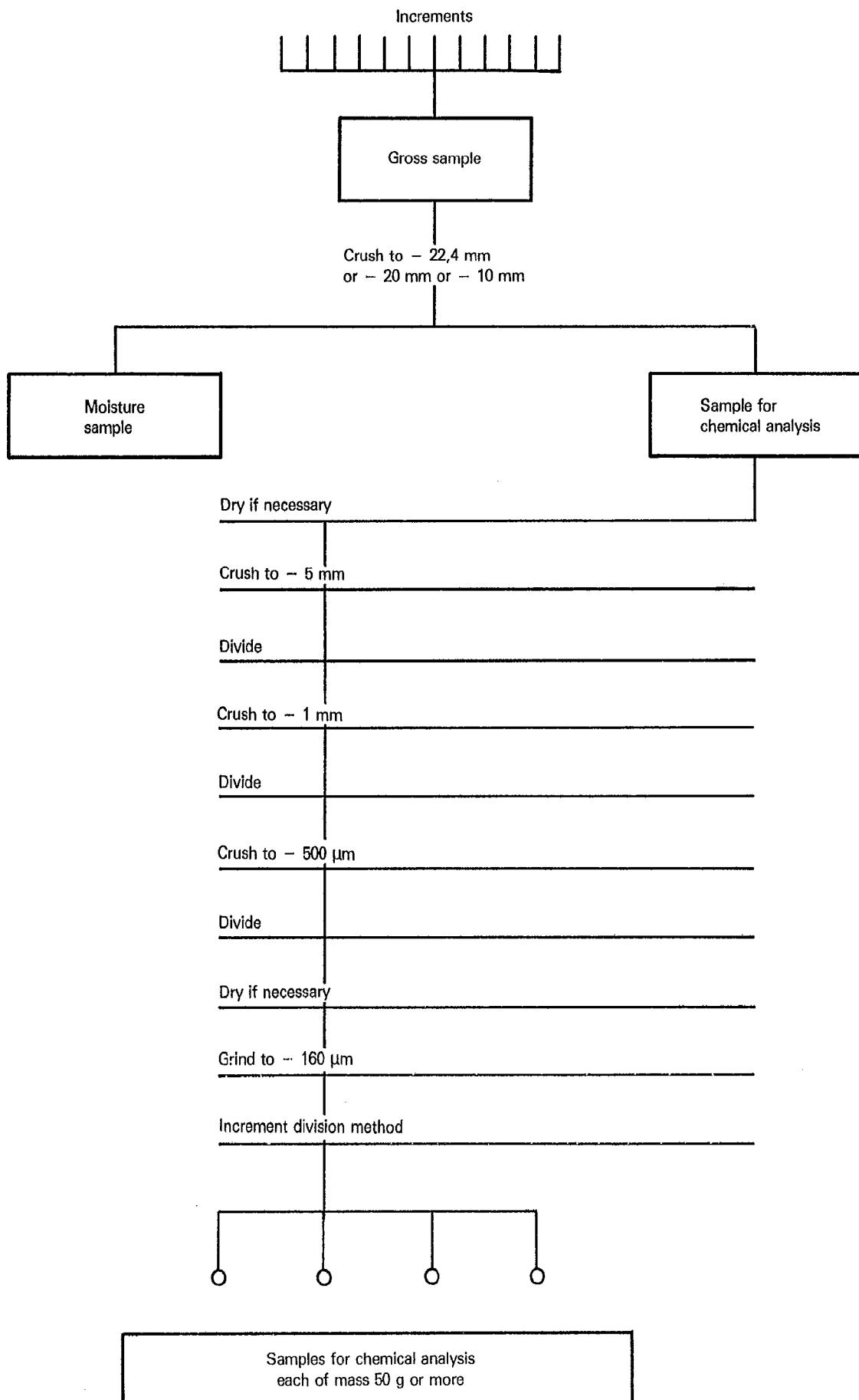

Figure 3 — Example of sample preparation

## Annex A (normative)

### Types of riffle divider

Table 12 — Dimensions of riffle dividers

Riffle divider number			60	50	30	20	10	6
Number of riffles			12	12	12	16	16	16
Dimensions, mm	Body	A	60 ± 1	50 ± 1	30 ± 1	20 ± 1	10 ± 0,5	6 ± 0,5
		B	760	630	380	346	171	112
		C	300	250	170	105	55	40
		D	600	500	340	210	110	80
		E	360	300	200	135	75	60
		F	60	50	30	30	20	20
		G	340	340	340	210	110	80
		H	230	200	140	85	45	30
		J	770	640	390	360	184	120
	K	240	220	220	140	65	55	
	Receiver	M	240	220	220	140	65	55
		N	340	340	340	210	110	80
		P	300	250	170	105	55	40
		Q	80	75	55	35	20	15
		R	340	340	340	210	110	80
	Feeder	S	760	630	380	346	171	112
		T	400	400	300	200	120	80
		U	265	265	200	135	70	45
V		200	200	150	105	50	35	

#### NOTES

- 1 A is the specified dimension. The other dimensions are shown for example.
- 2 The number of riffles shall be even and not less than the number specified in the above table.
- 3 The sample receivers shall be fitted tightly to the opening of the divider to avoid scattering any fine ores.
- 4 The inside surface of the divider shall be smooth and free from rust.

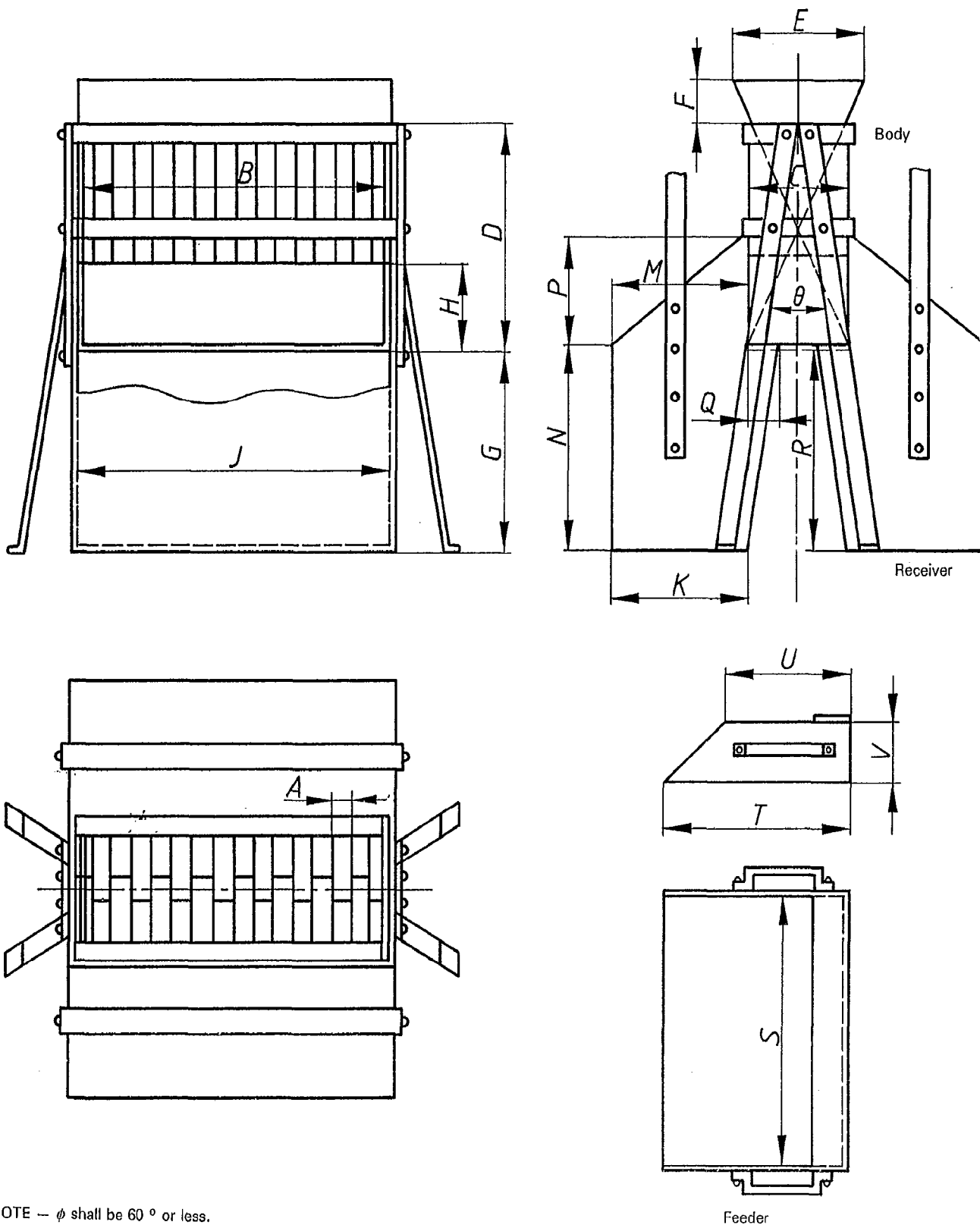

NOTE —  $\phi$  shall be  $60^\circ$  or less.

Figure 4 — Example of riffle divider

ISO 6154 : 1989 (E)

---

---

UDC 553.461 : 620.11

Descriptors : minerals and ores, chromate minerals, samples, specimen preparation.

Price based on 12 pages

---

---