**Connections for hydraulic fluid power
and general use — Ports and stud ends
with ISO 261 metric threads and O-ring
sealing —**

**Part 1:
Ports with truncated housing for O-ring
seal**

*Raccordements pour transmissions hydrauliques et applications
générales — Orifices et éléments mâles à filetage métrique ISO 261 et
joint torique —*

Partie 1: Orifices à joint torique dans un logement tronconique



PDF disclaimer

This PDF file may contain embedded typefaces. In accordance with Adobe's licensing policy, this file may be printed or viewed but shall not be edited unless the typefaces which are embedded are licensed to and installed on the computer performing the editing. In downloading this file, parties accept therein the responsibility of not infringing Adobe's licensing policy. The ISO Central Secretariat accepts no liability in this area.

Adobe is a trademark of Adobe Systems Incorporated.

Details of the software products used to create this PDF file can be found in the General Info relative to the file; the PDF-creation parameters were optimized for printing. Every care has been taken to ensure that the file is suitable for use by ISO member bodies. In the unlikely event that a problem relating to it is found, please inform the Central Secretariat at the address given below.

© ISO 2006

All rights reserved. Unless otherwise specified, no part of this publication may be reproduced or utilized in any form or by any means, electronic or mechanical, including photocopying and microfilm, without permission in writing from either ISO at the address below or ISO's member body in the country of the requester.

ISO copyright office
Case postale 56 • CH-1211 Geneva 20
Tel. + 41 22 749 01 11
Fax + 41 22 749 09 47
E-mail copyright@iso.org
Web www.iso.org

Published in Switzerland

Foreword

ISO (the International Organization for Standardization) is a worldwide federation of national standards bodies (ISO member bodies). The work of preparing International Standards is normally carried out through ISO technical committees. Each member body interested in a subject for which a technical committee has been established has the right to be represented on that committee. International organizations, governmental and non-governmental, in liaison with ISO, also take part in the work. ISO collaborates closely with the International Electrotechnical Commission (IEC) on all matters of electrotechnical standardization.

International Standards are drafted in accordance with the rules given in the ISO/IEC Directives, Part 2.

The main task of technical committees is to prepare International Standards. Draft International Standards adopted by the technical committees are circulated to the member bodies for voting. Publication as an International Standard requires approval by at least 75 % of the member bodies casting a vote.

Attention is drawn to the possibility that some of the elements of this document may be the subject of patent rights. ISO shall not be held responsible for identifying any or all such patent rights.

ISO 6149-1 was prepared by Technical Committee ISO/TC 131, *Fluid power systems*, Subcommittee SC 4, *Connectors and similar products and components*.

This second edition cancels and replaces the first edition (ISO 6149-1:1993), which has been technically revised.

ISO 6149 consists of the following parts, under the general title *Connections for hydraulic fluid power and general use — Ports and stud ends with ISO 261 metric threads and O-ring sealing*:

- *Part 1: Ports with truncated housing for O-ring seal*
- *Part 2: Dimensions, design, test methods and requirements for heavy-duty (S series) stud ends*
- *Part 3: Dimensions, design, test methods and requirements for light-duty (L series) stud ends*
- *Part 4: Dimensions, design, test methods and requirements of external and internal hexport plugs*

Introduction

In hydraulic fluid power systems, power is transmitted and controlled through a liquid under pressure within an enclosed circuit. In general applications, a fluid (liquid or gas) may be conveyed under pressure.

Components are connected through their threaded ports by fluid conductor connectors to tubes and pipes or to hose connectors and hoses.

Ports are an integral part of fluid power components, such as pumps, motors, valves, cylinders, etc.

For threaded ports and stud ends specified in new designs in hydraulic fluid power applications, ISO/TC 131/SC 4 recommends that the ISO 6149 series be used because these International Standards specify ports and stud ends with metric threads and O-ring sealing and because the subcommittee would like to help users by recommending one preferred system. ISO/TC 131/SC 4 further recommends that threaded ports and stud ends in accordance with the ISO 1179 series, ISO 9974 series and ISO 11926 series not be used for new designs in hydraulic fluid power applications; these International Standards are maintained because they specify ports and stud ends that are currently used in hydraulic systems worldwide.

Connections for hydraulic fluid power and general use — Ports and stud ends with ISO 261 metric threads and O-ring sealing —

Part 1: Ports with truncated housing for O-ring seal

1 Scope

This part of ISO 6149 specifies dimensions for metric ports for use with the adjustable and non-adjustable stud ends detailed in ISO 6149-2 and ISO 6149-3.

Ports in accordance with this part of ISO 6149 may be used at working pressures up to 63 MPa [630 bar¹⁾] for non-adjustable stud ends and 40 MPa (400 bar) for adjustable stud ends. The permissible working pressure depends upon port size, materials, design, working conditions, application, etc. See ISO 6149-2 and ISO 6149-3 for pressure ratings.

Users of this part of ISO 6149 should ensure that there is sufficient material around the port to maintain the pressure.

NOTE The Introduction of this part of ISO 6149 gives recommendations for ports and stud ends to be used for new designs in hydraulic fluid power applications.

2 Normative references

The following referenced documents are indispensable for the application of this document. For dated references, only the edition cited applies. For undated references, the latest edition of the referenced document (including any amendments) applies.

ISO 261, *ISO general purpose metric screw threads — General plan*

ISO 965-1, *ISO general purpose metric screw threads — Tolerances — Part 1: Principles and basic data*

ISO 2306, *Drills for use prior to tapping screw threads*

ISO 5598²⁾, *Fluid power systems and components — Vocabulary*

ISO 6149-2, *Connections for hydraulic fluid power and general use — Ports and stud ends with ISO 261 metric threads and O-ring sealing — Part 2: Dimensions, design, test methods and requirements for heavy-duty (S series) stud ends*

1) 1 bar = 0,1 MPa = 10⁵ Pa; 1 MPa = 1 N/mm².

2) To be published. (Revision of ISO 5598:1985).

ISO 6149-3³⁾, *Connections for fluid power and general use — Ports and stud ends with ISO 261 metric threads and O-ring sealing — Part 3: Dimensions, design, test methods and requirements for light-duty (L series) stud ends*

3 Terms and definitions

For the purposes of this part of ISO 6149, the terms and definitions given in ISO 5598 apply.

4 Dimensions

Ports shall conform to the dimensions shown in Figure 1 and given in Table 1.

Dimensions in millimetres,
values for surface roughness in micrometres

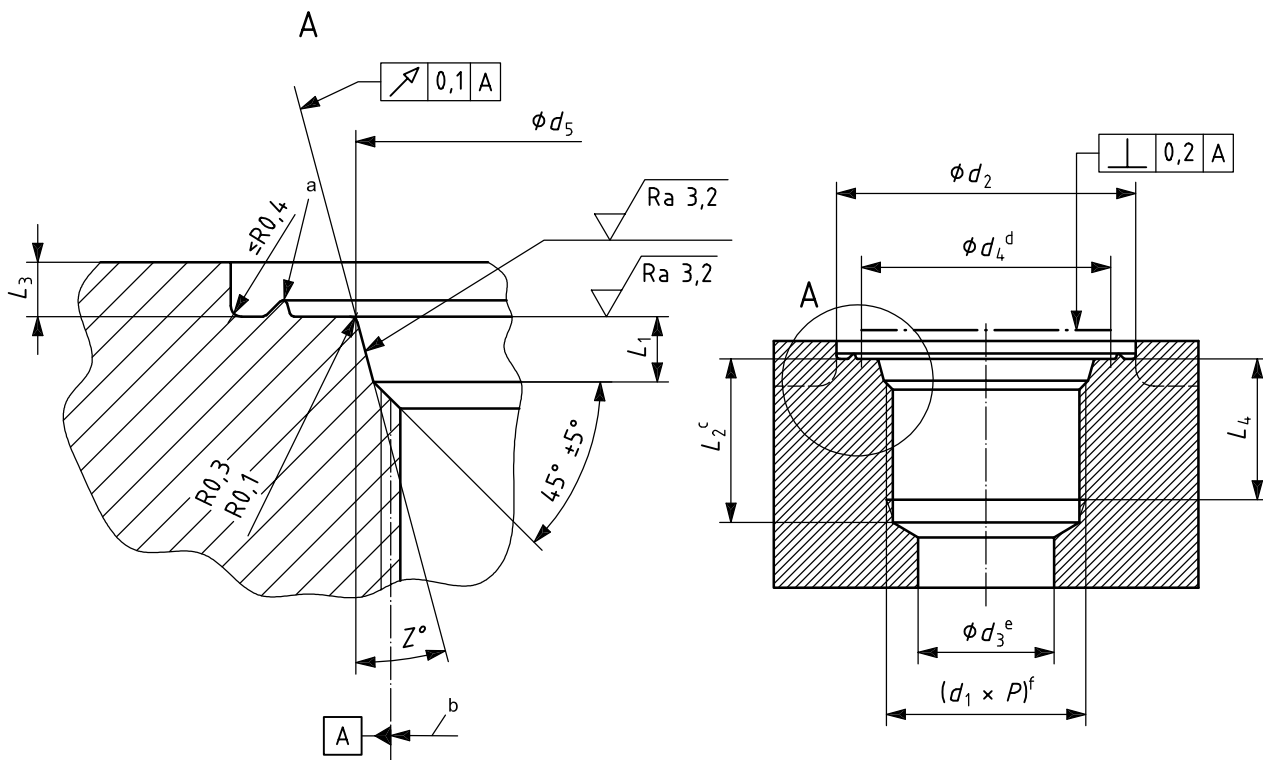

- a Optional identification of port; see Figure 2 and Clause 7.
- b Pitch diameter.
- c This dimension only applies when tap drill cannot pass through entire boss.
- d Gauging.
- e Reference only.
- f Thread.

Figure 1 — Port

3) To be published. (Revision of ISO 6149-3:1993).

Table 1 — Port dimensions

Dimensions in millimetres

Thread ^a ($d_1 \times P$)	d_2		d_3^b ref.	d_4	d_5 +0,1 0	L_1 +0,4 0	L_2^c min.	L_3 max.	L_4 min.	Z° $\pm 1^\circ$
	wide ^d min.	narrow ^e min.								
M8 × 1	17	14	3	12,5	9,1	1,6	11,5	1	10	12
M10 × 1	20	16	4,5	14,5	11,1	1,6	11,5	1	10	12
M12 × 1,5	23	19	6	17,5	13,8	2,4	14	1,5	11,5	15
M14 × 1,5 ^f	25	21	7,5	19,5	15,8	2,4	14	1,5	11,5	15
M16 × 1,5	28	24	9	22,5	17,8	2,4	15,5	1,5	13	15
M18 × 1,5	30	26	11	24,5	19,8	2,4	17	2	14,5	15
M20 × 1,5 ^g	33	29	—	27,5	21,8	2,4	—	2	14,5	15
M22 × 1,5	33	29	14	27,5	23,8	2,4	18	2	15,5	15
M27 × 2	40	34	18	32,5	29,4	3,1	22	2	19	15
M30 × 2	44	38	21	36,5	32,4	3,1	22	2	19	15
M33 × 2	49	43	23	41,5	35,4	3,1	22	2,5	19	15
M42 × 2	58	52	30	50,5	44,4	3,1	22,5	2,5	19,5	15
M48 × 2	63	57	36	55,5	50,4	3,1	25	2,5	22	15
M60 × 2	74	67	44	65,5	62,4	3,1	27,5	2,5	24,5	15

- ^a Conforming to ISO 261, tolerance grade 6H in accordance with ISO 965-1. Tap drills in accordance with ISO 2306, class 6H.
- ^b For reference only. Connecting hole application may require a different size.
- ^c The tap drill depths given require the use of a bottoming tap to produce the specified full thread lengths. Where standard taps are used, the tap drill depths shall be increased accordingly.
- ^d Spotface diameter with identification ridge.
- ^e Spotface diameter without identification ridge.
- ^f Preferred for diagnostic port applications.
- ^g For cartridge valve cavity applications only (see ISO 7789).

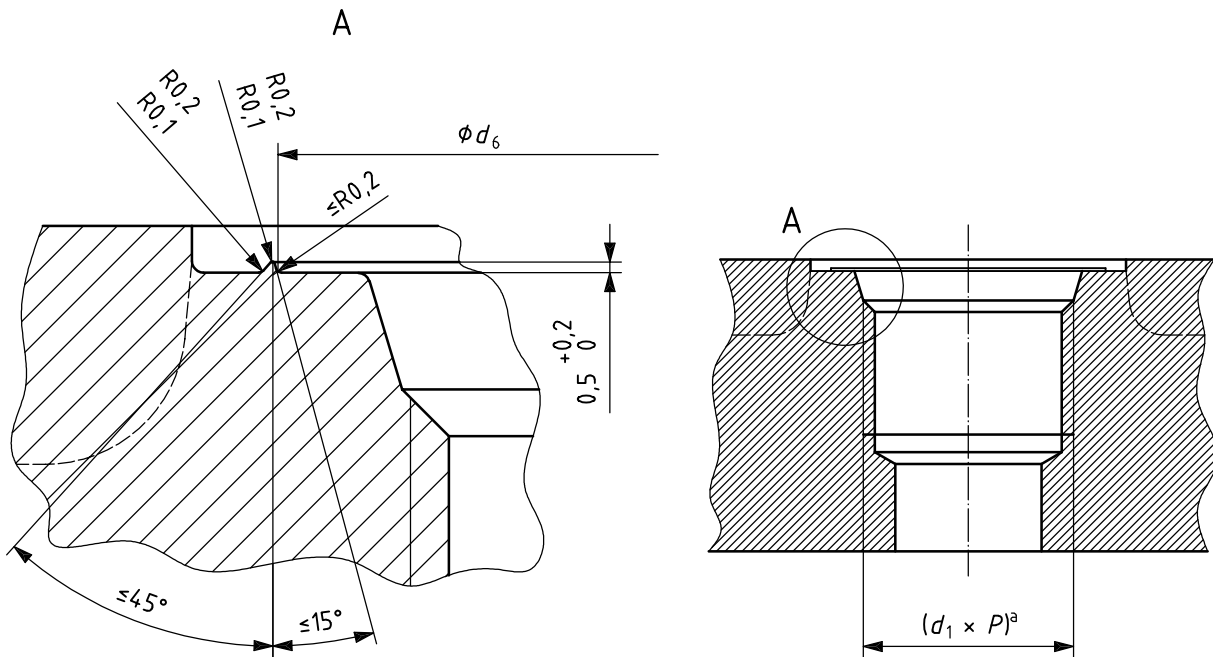

a Thread.

Figure 2 — Optional port identification

Table 2 — Optional port identification⁴⁾

Dimensions in millimetres

Thread ($d_1 \times P$)	d_6 $+0,5$ 0
M8 × 1	14
M10 × 1	16
M12 × 1,5	19
M14 × 1,5	21
M16 × 1,5	24
M18 × 1,5	26
M20 × 1,5 ^a	29
M22 × 1,5	29
M27 × 2	34
M30 × 2	38
M33 × 2	43
M42 × 2	52
M48 × 2	57
M60 × 2	67

^a For cartridge valve cavities only (see ISO 7789).

4) See Clause 7.

5 Test methods

Ports shall be tested along with stud ends in accordance with the test methods and requirements given in ISO 6149-2 and ISO 6149-3. For rated pressures lower than those specified in ISO 6149-2 and ISO 6149-3, the test pressures shall be agreed upon between the manufacturer and user.

6 Designation of ports

The ports shall be designated by

- a) "Port";
- b) reference to this part of ISO 6149, i.e. ISO 6149-1;
- c) thread size ($d_1 \times P$).

EXAMPLE A port in accordance with this part of ISO 6149, with a thread M18× 1,5 is designated as follows:

Port ISO 6149-1 - M18 × 1,5

7 Identification

Each port in accordance with this part of ISO 6149 shall be identified by a raised ring conforming to the dimensions given in Figure 2 and Table 2, or by permanently marking "metric" or "M" next to the port, or by a permanent identification label on the component to read "ISO 6149-1 metric ports".

8 Identification statement (reference to this part of ISO 6149)

It is strongly recommended to manufacturers who have chosen to conform to this International Standard that the following statement be used in test reports, catalogues and sales literature:

"Ports conform to ISO 6149-1:2006, *Connections for hydraulic fluid power and general use — Ports and stud ends with ISO 261 metric threads and O-ring sealing — Part 1: Ports with truncated housing for O-ring seal.*"

Bibliography

- [1] ISO 1101, *Technical drawings — Geometrical tolerancing — Tolerances of form, orientation, location and run-out — Generalities, definitions, symbols, indications on drawings*
- [2] ISO 1179-1⁵⁾, *Connections for general use and fluid power — Ports and stud ends with ISO 228-1 threads with elastomeric or metal-to-metal sealing — Part 1: Threaded ports*
- [3] ISO 1179-2⁵⁾, *Connections for general use and fluid power — Ports and stud ends with ISO 228-1 threads with elastomeric or metal-to-metal sealing — Part 2: Heavy-duty (S series) and light-duty (L series) stud ends and elastomeric sealing (type E)*
- [4] ISO 1179-3⁵⁾, *Connections for general use and fluid power — Ports and stud ends with ISO 228-1 threads with elastomeric or metal-to-metal sealing — Part 3: Light-duty (L series) stud ends with sealing by O-ring with retaining ring (types G and H)*
- [5] ISO 1179-4⁵⁾, *Connections for general use and fluid power — Ports and stud ends with ISO 228-1 threads with elastomeric or metal-to-metal sealing — Part 4: Stud ends for general use only with metal-to-metal sealing (type B)*
- [6] ISO 1302, *Geometrical Product Specifications (GPS) — Indication of surface texture in technical product documentation*
- [7] ISO 6410-1, *Technical drawings — Screw threads and threaded parts — Part 1: General conventions*
- [8] ISO 7789, *Hydraulic fluid power — Two-, three- and four-port screw-in cartridge valves — Cavities*
- [9] ISO 9974-1, *Connections for general use and fluid power — Ports and stud ends with ISO 261 threads or elastomeric or metal-to-metal sealing — Part 1: Threaded ports*
- [10] ISO 9974-2, *Connections for general use and fluid power — Ports and stud ends with ISO 261 threads or elastomeric or metal-to-metal sealing — Part 2: Stud ends with elastomeric sealing (type E)*
- [11] ISO 9974-3, *Connections for general use and fluid power — Ports and stud ends with ISO 261 threads or elastomeric or metal-to-metal sealing — Part 3: Stud ends with metal-to-metal sealing (type B)*
- [12] ISO 11926-1, *Connections for general use and fluid power — Ports and stud ends with ISO 725 threads and O-ring sealing — Part 1: Ports with O-ring seal in truncated housing*
- [13] ISO 11926-2, *Connections for general use and fluid power — Ports and stud ends with ISO 725 threads and O-ring sealing — Part 2: Heavy-duty (S series) stud ends*
- [14] ISO 11926-3, *Connections for general use and fluid power — Ports and stud ends with ISO 725 threads and O-ring sealing — Part 3: Light-duty (L series) stud ends*

5) To be published. (Partial revision of ISO 1179:1981).

.....

ICS 23.100.40

Price based on 6 pages