**Gas analysis — Preparation of calibration
gas mixtures using dynamic volumetric
methods —**

Part 10:
Permeation method

*Analyse des gaz — Préparation des mélanges de gaz pour étalonnage à
l'aide de méthodes volumétriques dynamiques —*

Partie 10: Méthode par perméation



Reference number
ISO 6145-10:2002(E)

© ISO 2002

PDF disclaimer

This PDF file may contain embedded typefaces. In accordance with Adobe's licensing policy, this file may be printed or viewed but shall not be edited unless the typefaces which are embedded are licensed to and installed on the computer performing the editing. In downloading this file, parties accept therein the responsibility of not infringing Adobe's licensing policy. The ISO Central Secretariat accepts no liability in this area.

Adobe is a trademark of Adobe Systems Incorporated.

Details of the software products used to create this PDF file can be found in the General Info relative to the file; the PDF-creation parameters were optimized for printing. Every care has been taken to ensure that the file is suitable for use by ISO member bodies. In the unlikely event that a problem relating to it is found, please inform the Central Secretariat at the address given below.

© ISO 2002

All rights reserved. Unless otherwise specified, no part of this publication may be reproduced or utilized in any form or by any means, electronic or mechanical, including photocopying and microfilm, without permission in writing from either ISO at the address below or ISO's member body in the country of the requester.

ISO copyright office
Case postale 56 • CH-1211 Geneva 20
Tel. + 41 22 749 01 11
Fax + 41 22 749 09 47
E-mail copyright@iso.ch
Web www.iso.ch

Printed in Switzerland

Contents

Page

Foreword.....	iv
Introduction.....	v
1 Scope	1
2 Normative reference	1
3 Principle.....	1
4 Reagents and materials	2
5 Apparatus	2
6 Procedure	5
6.1 Preliminary checks and operating conditions.....	5
6.2 Determination of mass loss.....	6
7 Expression of results	7
7.1 Calculation	7
7.2 Sources of uncertainty.....	8
7.3 Estimation of uncertainties.....	10
7.4 Example calculation of uncertainties	13
Annex A (informative) Example of uncertainty calculation for a two-pan continuous weighing system.....	14
Bibliography.....	16

Foreword

ISO (the International Organization for Standardization) is a worldwide federation of national standards bodies (ISO member bodies). The work of preparing International Standards is normally carried out through ISO technical committees. Each member body interested in a subject for which a technical committee has been established has the right to be represented on that committee. International organizations, governmental and non-governmental, in liaison with ISO, also take part in the work. ISO collaborates closely with the International Electrotechnical Commission (IEC) on all matters of electrotechnical standardization.

International Standards are drafted in accordance with the rules given in the ISO/IEC Directives, Part 3.

The main task of technical committees is to prepare International Standards. Draft International Standards adopted by the technical committees are circulated to the member bodies for voting. Publication as an International Standard requires approval by at least 75 % of the member bodies casting a vote.

Attention is drawn to the possibility that some of the elements of this part of ISO 6145 may be the subject of patent rights. ISO shall not be held responsible for identifying any or all such patent rights.

ISO 6145-10 was prepared by Technical Committee ISO/TC 158, *Analysis of gases*.

It cancels and replaces ISO 6349:1979 which has been technically revised.

ISO 6145 consists of the following parts, under the general title *Gas analysis — Preparation of calibration gas mixtures using dynamic volumetric methods*:

- *Part 1: Methods of calibration*
- *Part 2: Volumetric pumps*
- *Part 4: Continuous injection method*
- *Part 5: Capillary calibration devices*
- *Part 6: Critical orifices*
- *Part 7: Thermal mass-flow controllers*
- *Part 9: Saturation method*
- *Part 10: Permeation method*

Diffusion will be the subject of a future part 8 to ISO 6145. Part 3 to ISO 6145, entitled *Periodic injections into a flowing gas stream*, has been withdrawn by Technical Committee ISO/TC 158, *Analysis of gases*.

Annex A of this part of ISO 6145 is for information only.

Introduction

This part of ISO 6145 is one of a series of standards dealing with various dynamic volumetric methods used for the preparation of calibration gas mixtures.

Gas analysis — Preparation of calibration gas mixtures using dynamic volumetric methods —

Part 10: Permeation method

1 Scope

This part of ISO 6145 specifies a dynamic method using permeation membranes for the preparation of calibration gas mixtures containing component mole fractions ranging from 10^{-9} and 10^{-6} . A relative expanded uncertainty of 2,5 % of the component mole fraction can be achieved using this method. In the mole fraction range considered, it is difficult to maintain some gas mixtures, for example in cylinders, in a stable state. It is therefore desirable to prepare the calibration gas immediately before use, and to transfer it by the shortest possible path to the place where it is to be used. This technique has been successfully applied in generating low content calibration gas mixtures of, for example, sulfur dioxide (SO₂), nitrogen dioxide (NO₂) and benzene (C₆H₆) in air.

If the carrier gas flow is measured as a gas mass-flow, the preparation of calibration gas mixtures using permeation tubes is a dynamic-gravimetric method which gives contents in mole fractions.

2 Normative reference

The following normative document contains provisions which, through reference in this text, constitute provisions of this part of ISO 6145. For dated references, subsequent amendments to, or revisions of, any of these publications do not apply. However, parties to agreements based on this part of ISO 6145 are encouraged to investigate the possibility of applying the most recent edition of the normative document indicated below. For undated references, the latest edition of the normative document referred to applies. Members of ISO and IEC maintain registers of currently valid International Standards.

ISO 6145-1, *Gas analysis — Preparation of calibration gas mixtures using dynamic volumetric methods — Part 1: Methods of calibration*

3 Principle

The calibration component [for example SO₂, NO₂, ammonia (NH₃), benzene, toluene, xylene] is permeated through an appropriate membrane into the flow of a carrier gas, i.e. the complementary gas of the mixture obtained. The calibration component, of known purity, is contained in a tube, which is itself contained in a temperature-controlled vessel. This vessel is purged at a known and controlled flow rate by the carrier gas. The composition of the mixture is determined from the permeation rate of the calibration component as well as the flow rate of the high quality carrier gas, free from any trace of the calibration component and from any chemical interaction with the material of the permeation tube.

The permeation rate of the calibration component through the membrane depends upon the component itself, the chemical nature and structure of the membrane, its area and thickness, the temperature, and the partial pressure gradient of the calibration component across the membrane. These factors can be kept constant by proper operation of the system.

The permeation rate can be measured directly by mounting the tube on a microbalance and weighing the tube either continuously or periodically.

4 Reagents and materials

4.1 Permeating substances for calibration, of the highest possible purity so as to avoid any effect of impurities on the permeation rate; if this is not possible, the nature and quantities of the impurities shall be known and allowance made for their effect.

4.2 Carrier gas, of known purity, established by an appropriate analytical technique, for example, gas chromatography (GC) and/or Fourier transform infrared (FTIR) spectrometry.

5 Apparatus

5.1 Permeation apparatus, typically consisting of one of two modes (5.1.1 and 5.1.2) of application of the permeation method.

The materials of the permeation apparatus shall be chosen so as to avoid any effect on the content of the calibration component by sorption (chemical or physical). The smaller the desired final content, the greater the effect of adsorption phenomena. If possible, use glass as the housing of the temperature-controlled permeation tube. Choose flexible and chemically inert tube materials and metals, especially having regard to the transfer of the gas between the permeation apparatus and the analyser. Pay special attention to all junctions so as to keep them free from leaks.

The flow range of the carrier gas is kept constant by a control system and is monitored by a flowmeter. The value of the flow rate can, for example, be controlled by means of a mass flow controller and determined using a mass flowmeter.

The existence of an outlet for surplus gas enables the analyser under calibration to take the gas flow rate necessary for its proper operation, the remainder of the flow of gas being vented to atmosphere.

5.1.1 Periodic-weighing-mode permeation apparatus, consisting of a permeation tube kept in a temperature-controlled enclosure, swept by carrier gas. The permeation tube is periodically removed from the enclosure to be weighed.

Typical examples are given in Figures 1 and 2.

5.1.2 Continuous-weighing-mode permeation apparatus, consisting of a permeation tube kept in a temperature-controlled enclosure, swept by carrier gas. The permeation tube is suspended from a weighing device and weighed continuously.

A typical example is given in Figure 3.

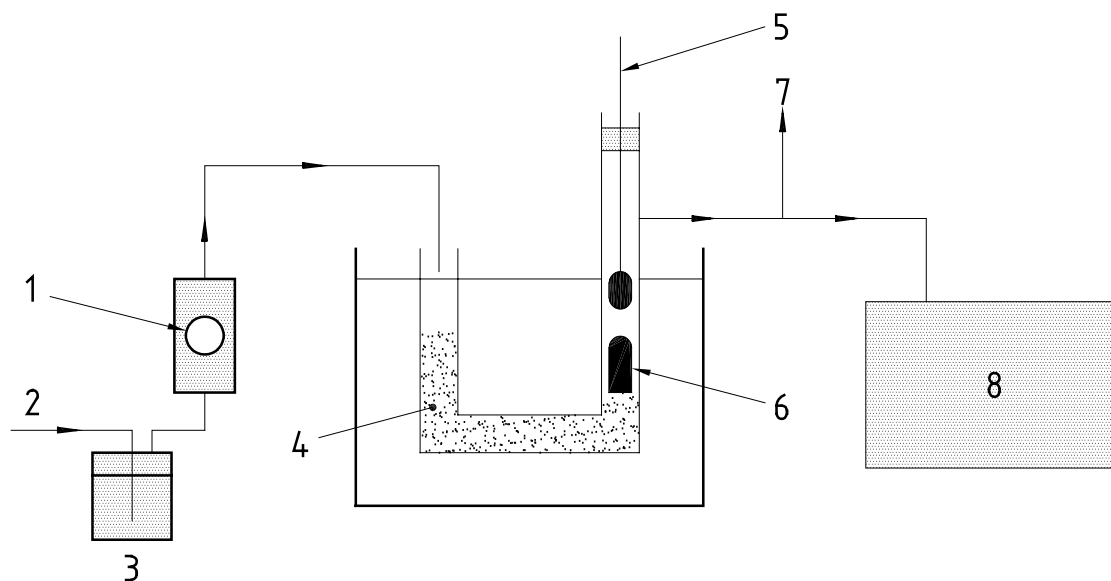

Key

- | | |
|---------------|--------------------------|
| 1 Flowmeter | 5 Thermometer |
| 2 Carrier gas | 6 Permeation tube |
| 3 Drier | 7 Outlet for surplus gas |
| 4 Filter | 8 Analyser |

Figure 1 — Example 1 of a periodic-weighing-mode permeation apparatus

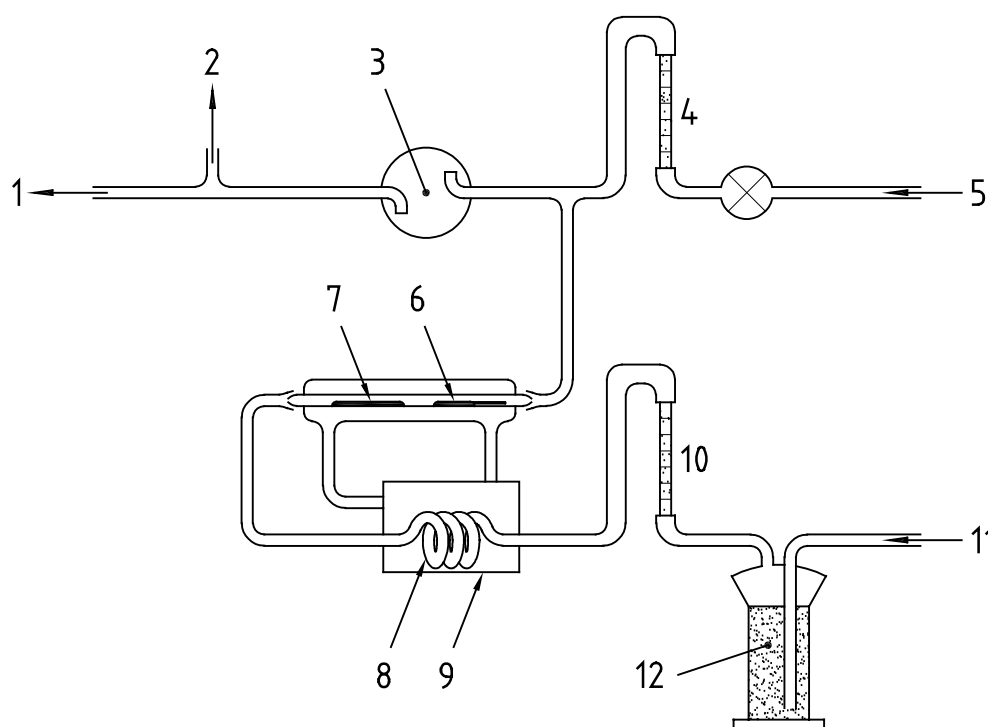

Key

- | | | |
|--------------------------|-------------------|----------------|
| 1 Outlet for surplus gas | 5 Diluent gas | 9 Water bath |
| 2 Sampling system | 6 Thermometer | 10 Flowmeter 1 |
| 3 Mixing bulb | 7 Permeation tube | 11 Carrier gas |
| 4 Flowmeter 2 | 8 Copper tubing | 12 Drier |

Figure 2 — Example 2 of a periodic-weighing-mode permeation apparatus

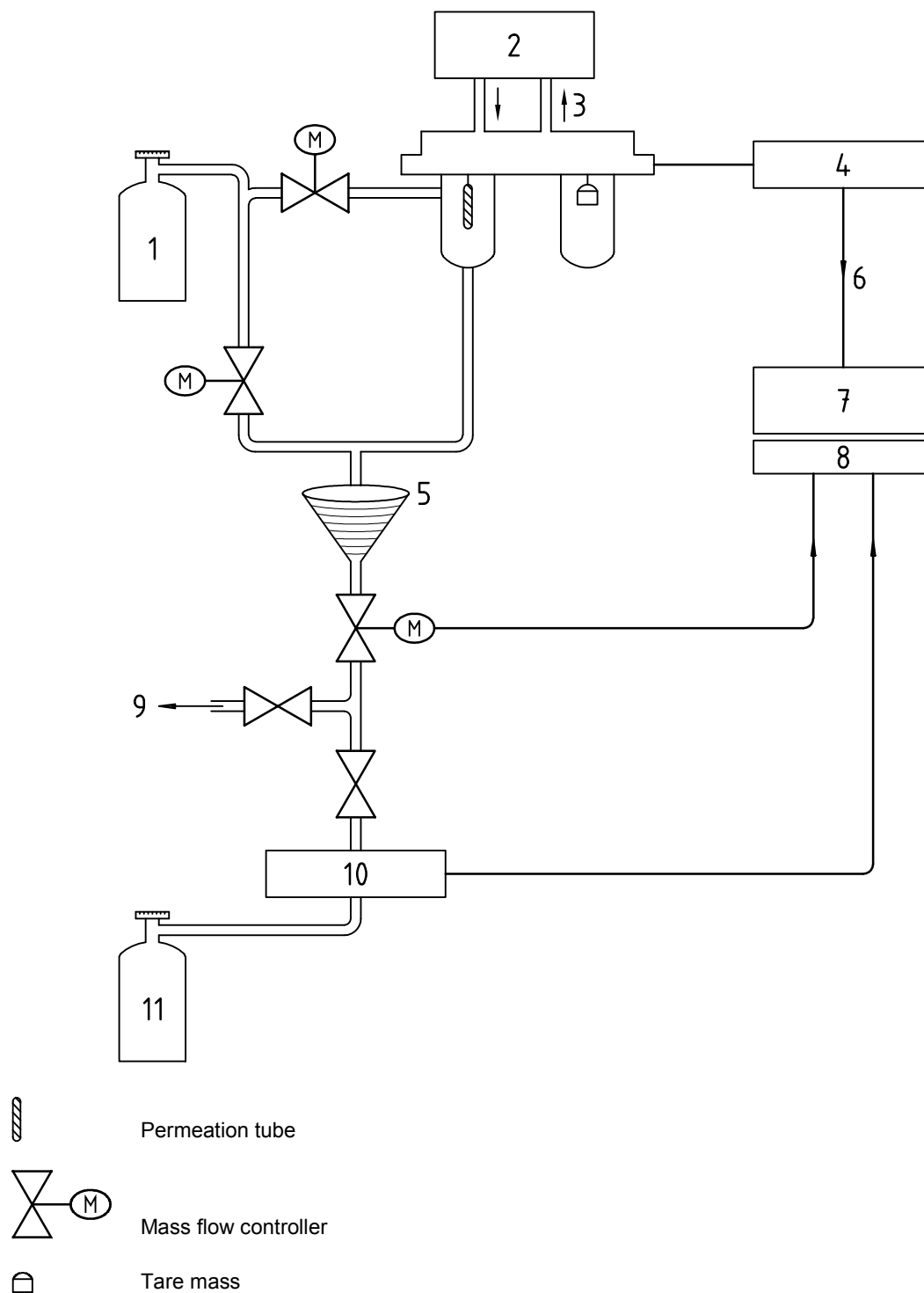

- Key**
- | | | |
|----------------------------------|--|---|
| 1 High purity air/N ₂ | 5 Gas blender | 9 Flow rate calibration facility |
| 2 Temperature controller | 6 RS232 link | 10 Gas analyser |
| 3 Water | 7 PC (acquisition, analysis and diagnostics) | 11 Stable mixture requiring certification |
| 4 Microbalance controller | 8 16-bit ADC | |

Figure 3 — Continuous-weighing-mode permeation apparatus

5.2 Permeation membrane, made from polymers and having sufficient chemical and mechanical resistance, e.g. suitable polytetrafluoroethylene (PTFE), polyethylene, polypropylene or a copolymer of tetrafluoroethylene and hexafluoropropylene (FEP).

Take into account variations of the material characteristics which occur with a change of temperature.

5.3 Permeation tubes, or containers, made of stainless steel or glass, fitted with a permeation membrane (5.2) and capable of holding the calibration component in the liquid phase and gaseous phase; the membrane through which the permeation takes place may be in contact with the liquid phase only, or with the gaseous phase only, or with both.

See examples given in Figure 4.

Before use, keep the permeation tube in an airtight container under an anhydrous atmosphere in a cold place (e.g. in a refrigerator at approximately 5 °C) so as to maintain the diffusion rate as low as possible, hence to minimize loss of the calibration component and avoid any condensation on the tube.

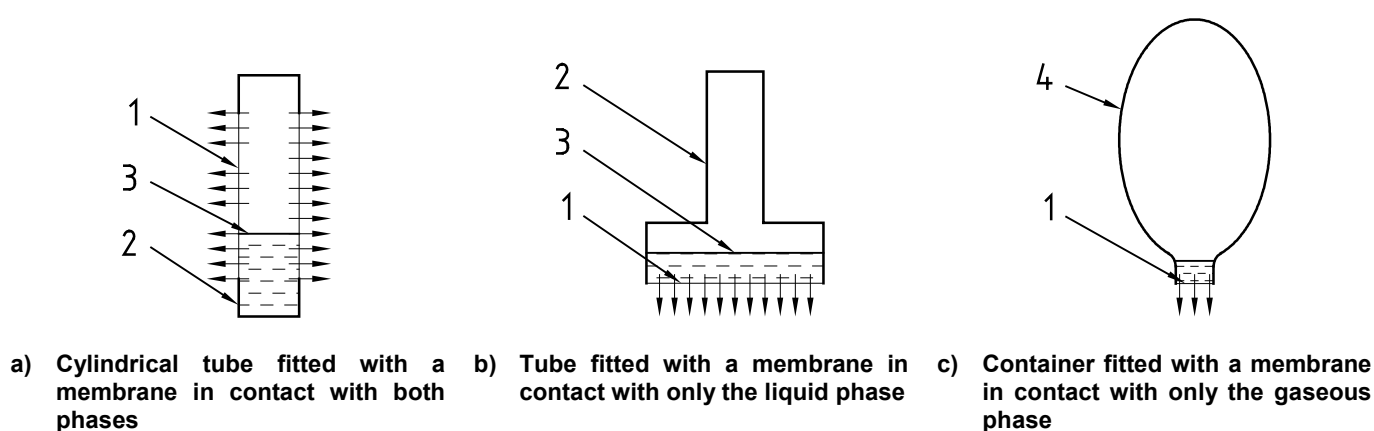

Key

- 1 Membrane
- 2 Stainless steel
- 3 Liquid level
- 4 Glass

Figure 4 — Examples of permeation tubes and container

6 Procedure

6.1 Preliminary checks and operating conditions

6.1.1 Permeation tube

Before use, assess the purity of the product of the permeation tube by collecting a sample of the permeated gas for analysis by an appropriate analytical technique [e.g. GC or FTIR] so as to quantify any likely major contaminants. This information may be provided by the suppliers of the tube and, if so, a certificate of analysis by an accredited body shall be provided.

Periodically check the permeation rate of the tube at a known, fixed temperature by measuring the mass loss. This gives a good indication as to the purity of the permeated gas. If the permeation rate changes by more than 10 % at the known, fixed temperature, discard the permeation tube.

When first using the permeation tube, allow the system to reach a state of equilibrium before carrying out the first weighing so as to ensure that the permeation rate is well stabilized at the constant value. The time needed to reach

equilibrium is dependant on the component contained within the permeation tube, but a value of 72 h is applicable to most species.

For most applications, it is essential to control the temperature of the enclosure to within 0,1 K because of the very strong dependence of the permeation rate upon temperature. The tube diffusion rate may, for example, double for an increase in temperature of approximately 7 K. Under certain circumstances, in which the diffusing gas is highly soluble in the membrane polymer, an increase in temperature may reduce the permeation rate.

During the period of use, maintain the permeation tube at constant temperature, principally to avoid the delay, sometimes very lengthy, which is necessary to restore equilibrium. Avoid any rapid changes in temperature.

If the operating conditions change significantly (e.g. a change in operating temperature), allow a period of 72 h for the permeation tube to re-equilibrate before resuming measurements.

6.1.2 Carrier gas flow configuration

Before the carrier gas reaches the tube, it is essential that its temperature be controlled at that of the permeation tube. Any system which enables the carrier gas to remain in the temperature-controlled enclosure for a sufficient period of time is satisfactory.

To change the content of the calibration mixture, adjust the carrier gas flow rate and the diluent gas flow rate (avoiding any change of the tube permeation rate as a result of temperature change); in this case, equilibrium is rapidly obtained. Refer to Figures 1 and 2 for the distinction between carrier gas flow and diluent gas flow. The dilution system shall have one or two stages, the first to carry gas away from the tube, the second to achieve the required concentration. Figure 1 shows an example of a single-stage dilution and Figures 2 and 3 shows examples of a two-stage dilution.

In the two-stage dilution procedure, establish the carrier gas flow at a suitable flow rate until temperature stability is attained. The desired content of the calibration component is then achieved by adjustment of the diluent gas flow rate, thus avoiding any disturbance to the thermal equilibrium of the permeation tube.

6.1.3 Choice of temperature

The choice of temperature depends on the tube characteristics and the permeation rate required. To carry out temperature control, establish thermal equilibrium within the permeation apparatus at a value close to the ambient value, or at a temperature sufficiently above the ambient value so as to ensure that no effect results from variations in the latter.

The choice of a temperature close to ambient temperature has two advantages:

- a) accurate control of temperature can be achieved more easily near ambient temperature;
- b) the temperature of the carrier gas can be more easily controlled.

6.1.4 Handling the tube

Ensure that all weighing is performed with extreme cleanliness and avoid any direct contact with the operator's hands. Use gloves and clean tweezers.

6.2 Determination of mass loss

Make sure the temperature and relative humidity of the air in the weighing room are controlled and kept constant during successive weighings. Weigh the tube and return it to the temperature-controlled environment after the weighing procedure. Keep the time that the permeation tube spends outside the temperature controlled environment to a minimum. Do not remove the permeation tube from the weighing enclosure if a continuous weighing procedure is used.

In a given time interval, the permeation device will decrease in mass. The measurement of this change in mass will have an associated measurement uncertainty. Therefore, the choice of the time interval over which weighings are made depends on the required accuracy, expressed as a fraction of the total mass loss. Choose the time interval such that the weighing uncertainty is a small fraction (e.g. < 1 %) of the mass loss of the permeation tube during this interval. In the case of the continuous weighing mode, choose the rate of frequency at which weighings are to be recorded to be as close as possible to the value obtained by dividing the permeation rate by the precision of the weighing balance. This will indicate systematic deviations from a constant mass loss rate. For example, a permeation rate of $2,0 \times 10^{-6}$ g/min and a balance resolution of 1×10^{-6} g would suggest a sampling rate of 2/min.

7 Expression of results

7.1 Calculation

The mass concentration of the calibration component A in the resulting gas mixture, β , is given by:

$$\beta = \frac{q_m(A)}{q_V} \quad (1)$$

where

$q_m(A)$ is the permeation rate (mass flow) of the calibration component A having dimensions MT^{-1} and, for example, expressed in micrograms per minute ($\mu\text{g}/\text{min}$);

q_V is the total volume flow rate of the complementary gas plus the flow rate of the component gas, having dimensions L^3T^{-1} and, for example, expressed in cubic metres per minute (m^3/min).

For practical purposes, the flow rate q_V of the component can be neglected. In the case of the two-stage dilution procedure the flow rate q_V is the sum of the flow rates of the carrier gas and the diluent gas.

The above calculation then gives the mass concentration of the gas mixture, β , in dimensions of ML^{-3} , for example in units of micrograms per cubic metre ($\mu\text{g}/\text{m}^3$). Note, in this case, the concentration is dependent on the pressure and temperature conditions.

The calculated concentration can be converted into a mole fraction, $x(A)$, by taking into account the molar mass, $M(A)$, of the component gas and the molar mass, M_{tot} , of the sum of the gases under measurement conditions. The mass flow rate of the mixture can be calculated from the multiplication of volume flow rate, $q_{V,\text{tot}}$, and the density, ρ_{tot} , of the mixture under measurement conditions; the molar mass flow rate is then obtained by dividing $q_{V,\text{tot}} \rho_{\text{tot}}$ by M_{tot} . For practical purposes the density and the molar mass of the carrier gas under measurement conditions can be used:

$$x(A) = \frac{q_m(A) / M(A)}{q_{V,\text{tot}} \cdot \rho_{\text{tot}} / M_{\text{tot}}} = \frac{q_m(A) \cdot M_{\text{tot}}}{q_{V,\text{tot}} \cdot \rho_{\text{tot}} \cdot M(A)} \quad (2)$$

where $q_{V,\text{tot}}$ is total volume flow rate of the mixture.

Equations (1) and (2) give:

$$x(A) = \frac{\beta(A) \cdot M_{\text{tot}}}{\rho_{\text{tot}} \cdot M(A)} \quad (3)$$

Alternatively, if the carrier gas flow is measured as a mass flow of gas, $q_{m,CG}$, the mole fraction of the resultant gas mixture can be calculated by taking into account the molar mass, $M(A)$, of the calibration component and that, M_{CG} , of the carrier gas. The flow of the calibration component can usually be neglected in the sum of the mass flow so that:

$$x(A) = \frac{q_m(A) / M(A)}{q_{m,CG} / M_{CG}} \quad (4)$$

The results may be expressed in any appropriate units.

It should be noted that Equations (1), (3) and (4) are related by constants, which have a negligible uncertainty associated with them (the typical relative uncertainty in molar mass is $\pm 10^{-5}$). Therefore, the relative uncertainty associated with the mole fraction is the same as that associated with the mass concentration.

7.2 Sources of uncertainty

7.2.1 General

There are several sources of uncertainty, the principal ones of which are identified in the following sub-clauses.

7.2.2 Impurities

As discussed above, before using a permeation apparatus for the preparation of gas mixtures, any impurities in the calibration component and carrier gases shall be identified and quantified, or upper limits placed on their relative concentrations. Appropriate analytical techniques (e.g. GC or FTIR) shall be used for this purpose. Frequent (e.g. weekly) checks on the permeation rate at a fixed temperature are a good means of verifying that a single component is permeating.

7.2.3 Substances undergoing polymerization or combining together

Some substances (e.g. vinyl chloride) may undergo polymerization or may combine together. This will have the effect of reducing the true concentration of the final gas mixture, and account shall be taken of this effect in determination of the total uncertainty.

7.2.4 Measurement of the mass loss rate from the permeation tube

There may be an error in the measurement of the mass loss rate from the permeation tube. This can result from an incorrect mass measurement or changes of the mass loss rate due to fluctuations in the temperature of the tube enclosure.

Uncertainties in the mass measurement usually result from deficiencies of the calibration of the weighing device and/or from the limited sensitivity of the balance. Weighing devices shall be traceably calibrated (see 7.3.2.2).

Changes of the mass loss rate due to temperature fluctuations will influence the measurement of the permeation rate for both measuring methods, i.e. continuous weighing and periodic weighing. When the continuous weighing method is used such changes of the permeation rate are recognized immediately and are in that way part of the observed variability. For the periodic weighing method, the possible deviations of the mass loss rate due to temperature fluctuations have to be taken into account as separate contributions to the total uncertainty (see 7.3.2.3).

7.2.5 Measurement of the flow rate of the carrier gas

There may be an error in the measurement of the flow rate of the carrier gas. This is minimized by regular traceable calibration of the flow-measuring device. The calibration uncertainty shall be considered in the overall uncertainty analysis.

7.2.6 Adsorption or desorption processes occurring on the walls of the apparatus

The calculated concentration of the final gas mixture may be in error as a result of adsorption or desorption processes occurring on the walls of the apparatus. Long term drifts in the apparent concentration (e.g. as measured by a gas analyser) of gas mixtures produced in this way are a good indication that these processes are occurring. Care shall be taken when materials for the apparatus (e.g. tubing and blending vessels) are selected in order to ensure that the effects of these processes are minimized. If these processes are unavoidable, then the apparatus shall be allowed to reach equilibrium before use.

7.2.7 Changes in buoyancy

The mass of air displaced by the permeation tube during weighing will affect the apparent mass. Compensation for this can be made by calculation of the magnitude of this buoyancy change. The true mass loss, Δm , of the permeation tube can be calculated according to Equation (5):

$$\Delta m = m_1 - m_2 + (\rho_2 - \rho_1)V \quad (5)$$

where

m_1 is the apparent mass of the permeation tube at the time of the first weighing;

m_2 is the apparent mass of the permeation tube at the time of the final weighing;

ρ_1 is the density of air at the time of the first weighing;

ρ_2 is the density of air at the time of the final weighing;

V is the volume of the permeation tube.

In the case in which the atmospheric conditions (temperature, pressure and humidity) remain constant in the interval between the initial and final weighing the buoyancy will remain constant and the determination of mass loss, given by the difference between the initial and final weighings, will not be subject to a buoyancy correction.

If a two pan balance configuration is used, this buoyancy effect shall be eliminated by employing a tare mass having the same volume as the permeation tube.

If a single pan balance configuration is used, then the buoyancy effect shall be eliminated by performing relative weighings against the same tare mass having a volume equal to that of the permeation tube.

7.2.8 Electrostatic influences

Electrostatic charging of the permeation tube and enclosure may disturb the weighing. Electrostatic influences can be reduced by the use of a wire gauze surrounding the weighing enclosure, a thin coating of metal (e.g. gold) around the weighing enclosure or the use of a weak radioactive source inside the weighing enclosure.

7.2.9 Possibility of leaks

The presence of a leak within the permeation apparatus will have an effect on the accuracy of the gas mixture. If there is a leak immediately after the carrier gas has swept over the permeation tube then the concentration of the prepared gas mixture will be lower than the value calculated using Equation (1). A thorough leak test of the permeation apparatus should be conducted before measurements are made using the system, and an upper limit placed on the magnitude of leaks present.

7.2.10 Measurement of time

The measurement of the time interval between weighings may be incorrect due to errors in the time measurement. This is minimized by regular traceable calibration of the measuring device. The calibration uncertainty shall be considered in the overall uncertainty analysis.

7.3 Estimation of uncertainties

7.3.1 Calculations

From Equation (1), the combined standard uncertainty in the mass concentration, $u_c(\beta)$, in terms of the standard uncertainties in the measurement of the permeation rate of the calibration component gas, $u(q_m)$, and the total complementary gas flow rate, $u(q_V)$, is given by

$$u_c^2(\beta) = \left[\frac{\partial \beta}{\partial q_m} \right]^2 u^2(q_m) + \left[\frac{\partial \beta}{\partial q_V} \right]^2 u^2(q_V) \tag{6}$$

and when the sensitivity coefficients are determined by differentiation of Equation (1), the expression for the relative standard uncertainty becomes:

$$\frac{u_c(\beta)}{\beta} = \sqrt{\left[\frac{u(q_m)}{q_m} \right]^2 + \left[\frac{u(q_V)}{q_V} \right]^2} \tag{7}$$

Alternatively, the uncertainties $u(q_m)$ and $u(q_V)$ can be expressed as relative uncertainties, $Z(q_m)$ and $Z(q_V)$. These relative uncertainties are independent and uncorrelated and can therefore be combined by squared summing [Equation (6)].

$$Z(\beta) = \sqrt{Z(q_m)^2 + Z(q_V)^2} \tag{8}$$

As discussed previously, it can be assumed that the relative uncertainty in the mole fraction is the same as that in the mass concentration.

7.3.2 Uncertainty in measurement of mass loss (permeation) rate

7.3.2.1 Regimes

This dominant source of uncertainty in the determination of the mass loss rate of the permeation tube depends on the time interval over which this measurement is made. Two regimes are distinguished here:

- a) Measurements are made over a relatively short timescale (e.g. 1 h), typical of measurements made by the continuous weighing technique, in which case the sensitivity of the balance is the dominant source of uncertainty. In this case long term drift of the temperature of the permeation tube will not affect the measurement of the mass loss rate.
- b) Measurements are made over a longer timescale (e.g. 1 week), typical of measurement made by the periodic weighing technique, in which case the long term drift of the temperature of the permeation tube will effect the instantaneous mass loss rate of the tube and will be the dominant source of uncertainty.

7.3.2.2 Uncertainty in mass loss rate dominated by balance sensitivity

The standard uncertainty $u(q_m)$ resulting from this effect can be estimated from a Type A evaluation of uncertainty (also see annex A). This is done by making repeated measurements of the mass loss rate of a permeation tube held at a fixed temperature over a time interval equal to that typically used for the determination of mass loss rates in generation of gas mixtures. $u(q_m)$ is then given by the standard deviation of these measurements. The uncertainty in the calibration of the balance shall also be taken into account.

7.3.2.3 Uncertainty in mass loss rate dominated by temperature variations of permeation tube

When the permeation tube is weighed periodically, the intervals between weighings should be longer than those described in 7.3.2.2 and the relative uncertainty in the mass loss rate resulting from the sensitivity of the balance will be small. The dominant source of uncertainty will be the variations in the temperature of the permeation tube over a relatively long period of time (typically 10 h). This can be estimated from a Type B evaluation of uncertainty (see also annex A).

If the rate of change of the permeation rate (q_m) with temperature around operating temperature T_{op} is given by $(\partial q_m / \partial T_{op})$ and the temperature stability of the temperature control instrumentation, as given by the standard deviation of the measured temperature stability of the temperature in the tube enclosure, is given by $S(T)$ the relative standard uncertainty in the permeation rate is given by:

$$\frac{u(q_m)}{q_m} = \frac{1}{q_m} \left(\frac{\partial q_m}{\partial T} \right)_{T_{op}} S(T) \quad (9)$$

NOTE For small temperature changes ($< 0,1$ K) the temperature dependency of the permeation rate as described by the manufacturer of the tubes can often be used as an approximate estimate of the term $(\partial q_m / \partial T)$ in the uncertainty calculation.

7.3.2.4 Uncertainty in mass loss rate dominated by changes in buoyancy

When the permeation tube is weighed a correction for changes in buoyancy shall be made and an associated uncertainty value assigned. The correction can be neglected if mass loss measurements are made against a tare mass or the buoyancy correction factor is significantly less than the dominant uncertainty in the measurement of mass loss from the permeation tube.

The density of air can be calculated with the equation for the determination of the density of moist air (see references [2] and [3] in the Bibliography). For the temperature range from 0 °C to 27 °C a simplified formula to calculate the density of air, expressed in kilograms per cubic metre, can be used:

$$10^3 \rho = \frac{[3,484\,88\,p - (8,037 + 737,4 \times 10^{-3}t + 975,25 \times 10^{-6}t^3)h]}{(273,15 + t)} \quad (10)$$

where

- p is the air pressure, expressed in hectopascals, at the time of the weighing;
- t is the temperature, expressed in degrees Celsius, at the time of the weighing;
- h is the relative humidity, expressed as a percentage, at the time of the weighing.

Table 1 shows the change in the density of air for two cases.

Table 1 — Change in the density of air

Condition	Density of air kg/m ³
24 °C, 986 hPa, 80 % relative humidity	1,145 8
18 °C, 1 040 hPa, 20 % relative humidity	1,242 9

If the assumed values for pressure (p_i), temperature (t_i expressed in degrees Celsius), relative humidity (h_i) and permeation tube volume (V), shown below (where $i = 1$ denotes the initial value and $i = 2$ the final value), are used to calculate the buoyancy correction factor then a value of $0,400 \mu\text{g} \pm 0,014 \mu\text{g}$ ($\pm 3,5 \%$) is obtained.

$$p_1 = 1\,040 \text{ hPa} \pm 0,5 \text{ hPa}$$

$$p_2 = 1\,000 \text{ hPa} \pm 0,5 \text{ hPa}$$

$$t_1 = 20 \text{ }^\circ\text{C} \pm 0,05 \text{ }^\circ\text{C}$$

$$t_2 = 20,5 \text{ }^\circ\text{C} \pm 0,05 \text{ }^\circ\text{C}$$

$$h_1 = 20 \text{ \%} \pm 1 \text{ \%}$$

$$h_2 = 30 \text{ \%} \pm 1 \text{ \%}$$

$$V = (7,853\,9 \pm 0,235\,6) \times 10^{-6} \text{ m}^3$$

The significance of the buoyancy correction is determined by comparison with the magnitude of the mass loss of the permeation tube between the initial and final weighings. For example, if the mass loss is 20 mg (permeation rate of around 2×10^{-6} g/min, one week between weighings), then the buoyancy effect gives a relative uncertainty of 2×10^{-5} in the measured mass loss of the permeation tube.

If the relative uncertainty in the mass loss due to buoyancy effects is a factor of 100 less than the most dominant relative uncertainty then it can be neglected. Otherwise, the buoyancy correction shall be made and the uncertainty in the correction evaluated using standard procedures.

The dominant uncertainties in the buoyancy correction factor will be those associated with the temperature, pressure and relative humidity measurements made in order to calculate the density of air at the time of weighing. The uncertainty in the volume of the permeation tube shall also be included.

7.3.3 Uncertainty in the measurement of complementary gas flow rate

An important source of uncertainty will be the absolute calibration of the flow-measuring device and the standard deviation of the measurements. An estimate of the standard uncertainty associated with this error can be obtained from a Type B evaluation of uncertainty (see annex A). The magnitude of this uncertainty will normally be given as part of the calibration procedure of the method. For example, for thermal mass flowmeters this uncertainty can be estimated by calibration of the device by one of the methods presented in ISO 6145-1, and will be of magnitude 0,5 % to 1,0 % of full scale reading.

7.3.4 Impurities within the calibration component and key impurities within the carrier gas

The carrier gas and, maybe, the liquefied calibration component will probably contain impurities which may affect the exact concentration of the gas mixtures prepared by this method. It is therefore necessary to carry out analysis for certain impurities within the carrier gas and the calibration component, as these impurities may cause degradation of the accuracy and stability of the final gas mixture. The impurities within the calibration component will have an effect upon the accuracy of the gas mixture, and this will be different from the effect of impurities in the carrier gas.

The calculation in 7.1 assumes that the calibration component is in a pure state. Any impurities within this component, and which also permeate through the walls of the permeation tube, will result in a prepared gas mixture with a concentration which is lower than the value calculated according to Equation (1) (non-permeating impurities should not affect q_m).

Impurities in the carrier gas play a different role in affecting the concentration of the prepared gas mixture. For example:

- If the calibration component is present as an impurity within the carrier gas, the concentration of the prepared gas mixture will clearly be higher than that value calculated by Equation (1). Therefore, the concentration of the calibration component within the carrier gas shall be analysed with sensitivity sufficient to show either that it makes no contribution to the overall uncertainty, or, that the concentration of the calibration component is below the limit of detection of the measurement. In the latter case, the value of this lower limit of detection shall be included as a contribution to the overall uncertainty in the concentration of the gas mixture containing that calibration component.
- If the carrier gas contains impurity species, which react with the calibration component, these will have a detrimental effect on the accuracy and stability of the final gas mixture. Analysis of the carrier gas for these impurities shall therefore be carried out with a sensitivity of detection that is adequate to demonstrate that such impurities are not present in significant concentrations within the carrier gas, or, an allowance for the instability shall be made when the overall uncertainty in the concentration of the prepared gas mixture is calculated.

7.4 Example calculation of uncertainties

An example of total uncertainty for a two-pan continuous weighing system is given in annex A.

Annex A (informative)

Example of uncertainty calculation for a two-pan continuous weighing system

The example given here is for a two-pan continuous weighing technique. The tare mass occupies the same volume as the permeation tube, so that buoyancy effects are eliminated.

As discussed in 7.3, there are several factors that contribute to the uncertainty in the mass concentration of the calibration component A in the resulting gas mixture, β . These are:

- Uncertainty in the permeation rate, $u(q_m)$ (relative uncertainty). A type A evaluation of the uncertainty in measurement of the permeation rate was carried out as follows. The mass of the tube was measured for 48 h and a permeation rate calculated for each 2-h period. The mean permeation rate within these 48 h and the standard deviation of the sample were then calculated as follows:

$$q_m = 1,06 \times 10^{-6} \text{ g/min}$$

$$u(q_m) = 7,77 \times 10^{-9} \text{ g/min}$$

- Uncertainty in the calibration of the balance, $Z_{m\text{cal}}$ (relative uncertainty). A type A evaluation of the uncertainty in the balance calibration was performed as follows. A set of standard mass pieces, traceable to National Standards of Mass, were weighed on the balance. The measured mass was compared with the actual mass stated on the calibration certificate for the set of standard masses. The uncertainty in the balance calibration was taken to be the mean difference between the measured and actual mass values as follows:

$$Z_{m\text{cal}} = 0,085 \%$$

NOTE A type B evaluation can be carried out using either an experimentally determined maximum (not mean) value, or in the absence of this value, the calibration uncertainty stated by the balance manufacturer.

- Uncertainty in the measurement of complementary gas flow rate, $u(q_V)$. A type A evaluation of this uncertainty was carried out as follows. Individual measurements of flow rate were made whilst preparing a calibration gas mixture. The mean flow rate and the standard deviation of the sample were then calculated as follows:

$$q_V = 1,525 \text{ l/min}$$

$$u(q_V) = 0,003 \text{ l/min}$$

- Uncertainty in the calibration of the flowmeter, $Z_{V\text{cal}}$ (relative uncertainty). A type A evaluation of the uncertainty in the flowmeter calibration was performed as follows. The flowmeter was calibrated, over a range of flow rates, against National Standards of Mass. The uncertainty in the flowmeter calibration was taken to be the mean difference between the measured and actual flow values as follows:

$$Z_{V\text{cal}} = 0,25 \%$$

NOTE A type B evaluation can be carried out using either an experimentally determined maximum difference or a manufacturer's stated calibration uncertainty.

- Uncertainty in the measurement of elapsed time, Z_{time} (relative uncertainty). A type B evaluation was carried out as follows. The permeation tube is weighed over a period of 1 h to 2 h, therefore, the uncertainty was taken to be 0,03 % (1 s in the hour).

$$Z_{\text{time}} = 0,03 \%$$

- Uncertainty due to the presence of leaks, Z_L (relative uncertainty). A type B evaluation was carried out as follows. A leak test, with a leak detection limit of 2 ml/h, was performed. No leak could be observed, therefore, an uncertainty of 2 ml/h for a flow rate of 3 000 ml/h (3 000 ml/h directed over the permeation tube) was assigned due to the presence of leaks.

$$Z_L = 0,07 \%$$

- Uncertainty due to impurities within the calibration component and carrier gas, Z_{imp} (relative uncertainty). A type B evaluation was performed to evaluate this uncertainty. The uncertainty is added directly to the total uncertainty.

$$Z_{imp} = \left(\frac{0,5}{200} \right) = 0,25 \%$$

where 0,5 and 200 are expressed as nanomole per mole (nmol/mol)

The uncertainties listed above can be expressed as relative uncertainties and are independent and uncorrelated. The relative combined standard uncertainty in the calibration gas mixture mass concentration can therefore be calculated using the following expression:

$$\frac{u_c(\beta)}{\beta} = \sqrt{\left(\frac{u(q_m)}{q_m} \right)^2 + \left(\frac{u(q_V)}{q_V} \right)^2 + Z_{mcal}^2 + Z_{Vcal}^2 + Z_{time}^2 + Z_L^2 + Z_{imp}^2} \quad (\text{A.1})$$

The above expression is also valid for the calculation of the relative combined standard uncertainty in the mole fraction of the gas mixture.

An example of the total uncertainty is given in the Table A.1.

The relative expanded uncertainty in the mole fraction of a calibration gas mixture with a mole fraction of 200×10^{-9} is $\pm 3,76 \times 10^{-9}$ ($\pm 1,88 \%$) at $k = 2$.

Table A.1 — Example of the total uncertainty

Source of uncertainty	Symbol	Type A or B	Probability distribution	Divisor	Example value
Calibration of balance	Z_{mcal}	A	normal	1	0,09 %
Permeation rate	$u(q_m)/q_m$	A	normal	1	0,73 %
Time measurement	Z_{time}	B	rectangular	$\sqrt{3}$	0,02 %
Possibility of leaks	Z_L	B	rectangular	$\sqrt{3}$	0,04 %
Flowmeter calibration	Z_{Vcal}	A	normal	1	0,25 %
Flow measurement	$u(q_V)/q_V$	A	normal	1	0,20 %
Summed in quadrature	—	—	—	—	0,80 %
Balance gas contamination ^a	Z_{imp}	B	rectangular	$\sqrt{3}$	0,14 %
Relative combined standard uncertainty	$u_c(\beta)/\beta$	—	normal	—	0,94 %
Relative expanded uncertainty	—	—	normal ($k = 2$)	—	1,88 %
^a Calibration gas concentration = 200 $\mu\text{mol/mol}$, balance gas contamination uncertainty = 0,14 %					

Bibliography

- [1] *Guide to the expression of uncertainty in measurement (GUM)*. BIPM, IEC, IFCC, ISO, IUPAC, IUPAP, OIML, 1st ed., corrected and reprinted in 1995
- [2] GIACOMO P. Equation for the determination of the density moist air (1981), *Metrologia*, **18**, 1982, pp. 33-40
- [3] DAVIS R.S. Equation for the determination of the density of moist air (1981, 91), *Metrologia*, **29**, 1992, pp. 67-70
- [4] ISO 7504, *Gas analysis — Vocabulary*

.....

.....

ICS 71.040.40

Price based on 16 pages

© ISO 2002 – All rights reserved