**Road vehicles — Elastomeric seals for
hydraulic disc brake cylinders using a
non-petroleum base hydraulic brake fluid
(Service temperature 120 °C max.)**

*Véhicules routiers — Joints en caoutchouc pour cylindres de freins
hydrauliques à disque utilisant un liquide de frein à base non pétrolière
(Température maximale d'utilisation: 120 °C)*



PDF disclaimer

This PDF file may contain embedded typefaces. In accordance with Adobe's licensing policy, this file may be printed or viewed but shall not be edited unless the typefaces which are embedded are licensed to and installed on the computer performing the editing. In downloading this file, parties accept therein the responsibility of not infringing Adobe's licensing policy. The ISO Central Secretariat accepts no liability in this area.

Adobe is a trademark of Adobe Systems Incorporated.

Details of the software products used to create this PDF file can be found in the General Info relative to the file; the PDF-creation parameters were optimized for printing. Every care has been taken to ensure that the file is suitable for use by ISO member bodies. In the unlikely event that a problem relating to it is found, please inform the Central Secretariat at the address given below.

© ISO 2006

All rights reserved. Unless otherwise specified, no part of this publication may be reproduced or utilized in any form or by any means, electronic or mechanical, including photocopying and microfilm, without permission in writing from either ISO at the address below or ISO's member body in the country of the requester.

ISO copyright office
Case postale 56 • CH-1211 Geneva 20
Tel. + 41 22 749 01 11
Fax + 41 22 749 09 47
E-mail copyright@iso.org
Web www.iso.org

Published in Switzerland

Contents

Page

Foreword.....	iv
1 Scope	1
2 Normative references	1
3 Product requirements	1
4 Brake test fluid	1
5 Apparatus	2
5.1 Apparatus for test of resistance to fluid at elevated temperature, physical stability and precipitation characteristics	2
5.2 Apparatus for high-temperature stroking test (see Figure 1)	2
5.3 Apparatus for low-temperature leakage test (see Figure 2)	3
6 Test requirements	3
7 Preparation of test specimens	4
8 Resistance to fluid at elevated temperature — Physical stability	4
8.1 Test specimens	4
8.2 Test procedure	4
9 Resistance to fluid at elevated temperature — Precipitation characteristics	5
9.1 Test specimens	5
9.2 Test procedure	5
10 Resistance to elevated temperature in dry air	6
10.1 Test specimens	6
10.2 Test procedure	6
11 Ambient-temperature stroking test	6
11.1 Test specimens	6
11.2 Test procedure	6
12 High-temperature stroking test	7
12.1 Test specimens	7
12.2 Test procedure	7
13 Low-temperature leakage test	8
13.1 Test specimens	8
13.2 Test procedure	8
13.3 Bend test procedure	9
14 Cycling humidity storage corrosion test	9
14.1 Test specimens	9
14.2 Test procedure	9

Foreword

ISO (the International Organization for Standardization) is a worldwide federation of national standards bodies (ISO member bodies). The work of preparing International Standards is normally carried out through ISO technical committees. Each member body interested in a subject for which a technical committee has been established has the right to be represented on that committee. International organizations, governmental and non-governmental, in liaison with ISO, also take part in the work. ISO collaborates closely with the International Electrotechnical Commission (IEC) on all matters of electrotechnical standardization.

International Standards are drafted in accordance with the rules given in the ISO/IEC Directives, Part 2.

The main task of technical committees is to prepare International Standards. Draft International Standards adopted by the technical committees are circulated to the member bodies for voting. Publication as an International Standard requires approval by at least 75 % of the member bodies casting a vote.

Attention is drawn to the possibility that some of the elements of this document may be the subject of patent rights. ISO shall not be held responsible for identifying any or all such patent rights.

ISO 6119 was prepared by Technical Committee ISO/TC 22, *Road vehicles*, Subcommittee SC 2, *Braking systems and equipment*.

This second edition cancels and replaces the first edition (ISO 6119:1980), which has been technically revised.

Road vehicles — Elastomeric seals for hydraulic disc brake cylinders using a non-petroleum base hydraulic brake fluid (Service temperature 120 °C max.)

1 Scope

This International Standard specifies the performance test methods and requirements for elastomeric seals used in road vehicle disc brake cylinders.

It is applicable to solid section type seals (square, rectangular, “O”-ring), mounted stationary in the cylinder bore or on the movable piston of disc brakes.

2 Normative references

The following referenced documents are indispensable for the application of this document. For dated references, only the edition cited applies. For undated references, the latest edition of the referenced document (including any amendments) applies.

ISO 48, *Rubber, vulcanized or thermoplastic — Determination of hardness (hardness between 10 IRHD and 100 IRHD)*

ISO 188, *Rubber, vulcanized or thermoplastic — Accelerated ageing and heat resistance tests*

ISO 1817, *Rubber, vulcanized — Determination of the effect of liquids*

ISO 4926, *Road vehicles — Hydraulic brake systems — Non-petroleum base reference fluids*

ISO 4928, *Road vehicles — Elastomeric cups and seals for cylinders for hydraulic braking systems using a non-petroleum base hydraulic brake fluid (Service temperature 120 °C max.)*

3 Product requirements

Seals shall conform to the pertinent drawing in all respects and shall be free from blisters, pin-holes, cracks, protuberances, embedded foreign material, or other physical defects which can be detected by thorough inspection.

These elastomeric seals shall be suitable for operation in a temperature range of –40 °C to +120 °C.

4 Brake test fluid

The test fluid for all tests except the test prescribed in Clause 14 shall be compatibility fluid as defined in ISO 4926. The fluid specified in Clause 14 shall be ISO fluid for storage corrosion test as defined in ISO 4926, or the fluid agreed by the parties concerned.

5 Apparatus

5.1 Apparatus for test of resistance to fluid at elevated temperature, physical stability and precipitation characteristics

5.1.1 **Oven**, uniformly heated, dry air type conforming to the requirements of ISO 188.

5.1.2 **Test jar**, screw-top straight-sided round glass type, having a capacity of approximately 250 ml and inner dimensions of approximately 125 mm height and 50 mm diameter, with a tinned steel lid (no insert or organic coating).

5.2 Apparatus for high-temperature stroking test (see Figure 1)

5.2.1 **Pneumatic or hydraulic pressure source.**

5.2.2 **Master cylinder.**

5.2.3 **Pressure gauge.**

5.2.4 **Wheel cylinder seat stroking fixture.**

5.2.6 **Cylinder assembly.**

5.2.7 **Oven**, in accordance with 5.1.1.

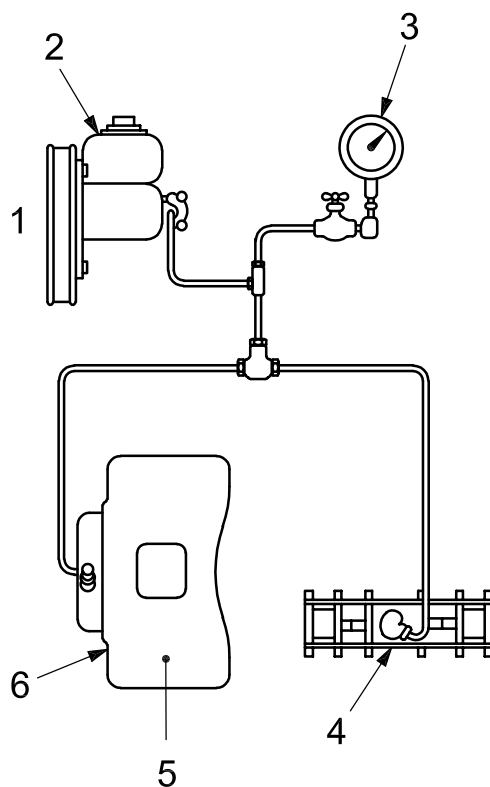

Key

- 1 pneumatic or hydraulic pressure source
- 2 master cylinder
- 3 pressure gauge
- 4 wheel cylinder seat stroking fixture
- 5 oven chamber at +120 °C
- 6 cylinder assembly

Figure 1 — High-temperature stroking test

5.3 Apparatus for low-temperature leakage test (see Figure 2)

5.3.1 Hydraulic pressure gauge.

5.3.2 Master cylinder.

5.3.3 Cylinder assembly.

5.3.4 Cold chamber, at $-40\text{ }^{\circ}\text{C}$.

Dimensions in millimetres

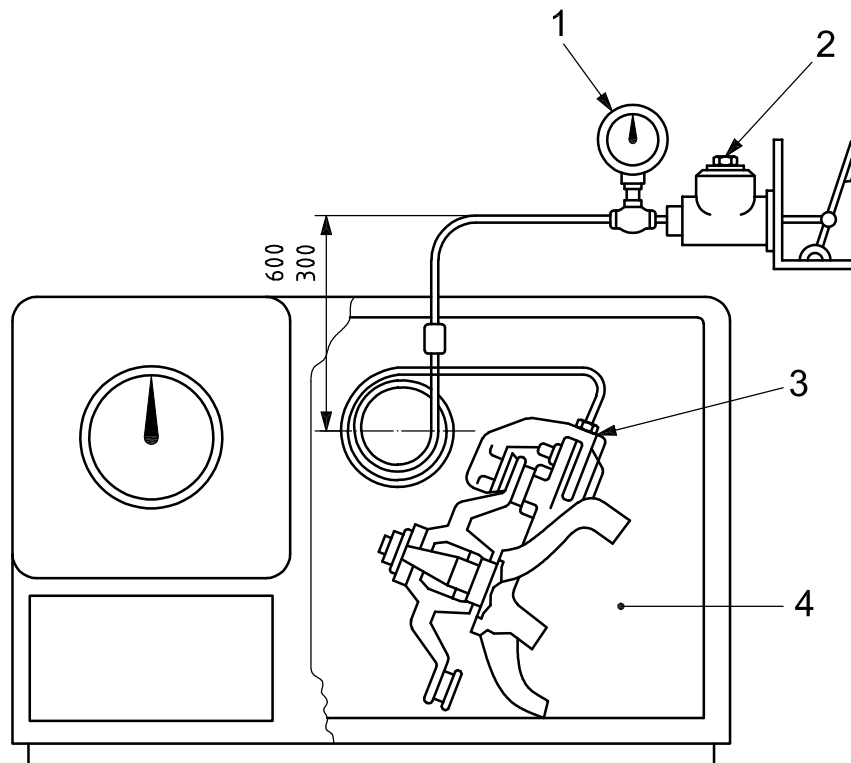

Key

- 1 hydraulic pressure gauge
- 2 master cylinder
- 3 cylinder assembly
- 4 cold chamber at $-40\text{ }^{\circ}\text{C}$

Figure 2 — Low-temperature leakage test

6 Test requirements

6.1 After the test for resistance to fluid at elevated temperature (physical stability) (see Clause 8), the seals shall conform to the following requirements:

- a) any change in volume shall be within 0 % to +15 %;
- b) any change in hardness shall be within 0 IRHD to -15 IRHD .

6.2 After the test for resistance to fluid at elevated temperature (precipitation characteristics) (see Clause 9), not more than 0,3 % sediment by volume shall be formed in the test fluid used.

6.3 After the test for resistance to elevated temperature in dry air (see Clause 10), the seals shall conform to the following requirements:

- a) any change in hardness shall be within 0 IRHD to +15 IRHD;
- b) test specimens shall show no evidence of blistering, cracking or change in shape from original form.

6.4 After the ambient-temperature stroking test (see Clause 11), seals and assembly shall conform to the following requirements:

- a) no leakage beyond normal wetting of the bore(s) shall occur during the stroking test;
- b) no leakage beyond normal wetting of the bore(s) shall occur during the static leak test (see 11.2.3).

6.5 After the high-temperature stroking test (see Clause 12), the seals and assembly shall conform to the following requirements:

- a) no leakage beyond normal wetting of the bore(s) shall occur during the stroking test;
- b) no leakage beyond normal wetting of the bore(s) shall occur during the static leak test (see 12.2.4).

6.6 After the low-temperature leakage test (see Clause 13), the seals and assembly shall conform to the following requirements:

- a) no leakage beyond normal wetting of the bore(s) shall occur during the test period or pressure application;
- b) the seal shall not crack, shall remain flexible and shall return to its approximate original shape within 1 min when tested according to the procedure given in 13.3.

6.7 After the cycling humidity storage corrosion test (Clause 14), the seals and assembly shall conform to the following requirements:

- a) no evidence of rubber adhesion of the test seal(s) shall appear during disassembly of the test brake;
- b) no surface of the sealing systems shall show evidence of corrosion or deterioration which would interfere with proper sealing action; normal staining or discoloration of metal parts is acceptable if the surface finish is unaffected.

6.8 After all the tests, disassemble the cylinder and inspect the seal. Record the visual condition of the seal bore and piston. Seals shall not show excessive deterioration such as scoring, scuffing, blistering, cracking or change in shape from original appearance.

7 Preparation of test specimens

All seals to be tested shall be cleaned prior to testing by rinsing in isopropanol then blown dry or wiped dry with a lint-free cloth. Seals shall not remain in the alcohol for more than 30 s.

8 Resistance to fluid at elevated temperature — Physical stability

8.1 Test specimens

From three or more seals to be tested, obtain a sample of mass 3 g to 5 g.

8.2 Test procedure

8.2.1 Determine and record the initial volume of the sample in accordance with ISO 1817.

8.2.2 Determine and record the initial hardness of the sample in IRHD. Measure the hardness as specified in ISO 48 using a microtester (or according to a procedure previously agreed upon between the vendor and purchaser).

8.2.3 Place the sample in the test jar (5.1.2) and completely immerse in 75 ml of brake test fluid (see Clause 4). Seal the test jar to prevent vapour loss and place in the oven (5.1.1) at $120\text{ °C} \pm 2\text{ °C}$ for 70 h.

8.2.4 After the 70 h, remove the sample from the oven and allow it to cool in the container at $23\text{ °C} \pm 5\text{ °C}$ for 60 min to 90 min. At the end of the cooling period, remove the sample from the container and rinse it in isopropanol or ethanol then wipe dry with a clean, lint-free cloth.

Do not allow the sample to remain in the alcohol for more than 30 s.

8.2.5 Within 60 min of removal from the liquid, determine and record the final volume and hardness, in IRHD, of each seal in accordance with 8.2.1 and 8.2.2.

Average the results and report as the change in volume and hardness.

8.2.6 Report the change in volume ΔV as a percentage of the original volume. It is given by the formula

$$\Delta V = \frac{(m_3 - m_4) - (m_1 - m_2)}{(m_1 - m_2)} \times 100\%$$

where

m_1 is the initial mass, in grams, in air;

m_2 is the initial apparent mass, in grams, in water;

m_3 is the mass, in grams, in air after immersion in the test fluid;

m_4 is the apparent mass, in grams, in water after immersion in the test fluid.

9 Resistance to fluid at elevated temperature — Precipitation characteristics

9.1 Test specimens

From two or more seals to be tested, obtain a sample of $4,0\text{ g} \pm 0,5\text{ g}$. Since whole seals are quite large, small pieces may be cut from the seal to arrive at the required mass. Use a minimum number of pieces to obtain a sample of mass $4,0\text{ g} \pm 0,5\text{ g}$.

9.2 Test procedure

9.2.1 Place the sample in a test jar (5.1.2) and cover with 75 ml of the test fluid (see Clause 4). Seal the test jar to prevent vapour loss and place in the oven (5.1.1) at $120\text{ °C} \pm 2\text{ °C}$. (Optional: a blank test may be conducted on the brake fluid prior to the test, and any sediment resulting from this blank test may be deducted from the volume of sediment obtained after the test.)

9.2.2 After 70 h, remove the test jar from the oven. Allow the sample to remain in the fluid at room temperature for 24 h, after which agitate the test fluid and pour into a cone-shaped centrifuge tube of 100 ml capacity.

9.2.3 Rotate the centrifuge tube for 30 min at $1\,500\text{ min}^{-1}$. Note the volume of sediment observed in the tube. Repeat the above rotation for an additional 30 min and record any difference in volume of sediment.

9.2.4 Record the percentage amount of sediment obtained after the second centrifuging.

10 Resistance to elevated temperature in dry air

10.1 Test specimens

Two or more seals shall be used.

10.2 Test procedure

10.2.1 Measure and record the hardness of each seal in IRHD in accordance with 8.2.2.

10.2.2 Place the test seals in a circulating air oven, as specified in ISO 188, and maintain at $120\text{ °C} \pm 2\text{ °C}$ for 70 h.

10.2.3 At the termination of the heating period, remove the seals from the oven and allow to cool for 16 h to 96 h at room temperature.

10.2.4 After cooling, measure and record the hardness in IRHD, in accordance with 8.2.2, and note any visual change such as cracking, blistering or distortion.

11 Ambient-temperature stroking test

11.1 Test specimens

An adequate number of test seals for at least one complete calliper shall be prepared.

11.2 Test procedure

11.2.1 Installation

11.2.1.1 Moisten the seals and calliper bores with brake test fluid (see Clause 4). Install the test seals in the cylinder.

11.2.1.2 Complete the test calliper assembly, placing the piston so as to simulate a half-worn lining position.

11.2.1.3 Mount the test calliper assembly on a production hub and disc assembly or equivalent simulating fixture.

11.2.1.4 Connect the test fixture to the pressure source. It may be necessary or desirable to include a fluid accumulator (see ISO 4928).

11.2.2 Test parameters

- a) Temperature: 18 °C to 32 °C .
- b) Pressure: Apply pressure by external means at a maximum rate-of-pressure rise of $(21,0 \pm 1,4)$ MPa/s from 0 MPa to $7,0\text{ MPa} \pm 0,3\text{ MPa}$.
- c) Total cycles required: 500 000 cycles.
- d) Cycle rate: $(1\ 000 \pm 100)$ strokes/h.

11.2.3 Leakage test

11.2.3.1 General

Observe for evidence of leakage during and after the stroking test. After completion of the stroking test, run high- and low-pressure leak tests.

11.2.3.2 High-pressure leak test

Apply 0,7 MPa of hydraulic pressure for 5 min and observe and record leakage, if any.

11.2.3.3 Low-pressure leak test

Remove the calliper from the test stand and connect the test calliper for 24 h to a pressure source at $10,00 \text{ kPa} \pm 1,75 \text{ kPa}$. Observe leakage, if any.

The pressure source may be a static column of fluid.

NOTE A 1 200 mm column will provide 10 kPa.

11.2.4 Final check

Disassemble the calliper and inspect the seal. Record the visual condition of the seal, bore and piston. Seals shall not show excessive deterioration such as scoring, scuffing, blistering, cracking or change in shape from original appearance.

12 High-temperature stroking test

12.1 Test specimens

An adequate number of test seals for at least one complete calliper shall be prepared.

12.2 Test procedure

12.2.1 Installation

12.2.1.1 Moisten the seals and calliper bores with brake test fluid (see Clause 4). Install the test seals in the cylinder.

12.2.1.2 Complete the test calliper assembly, placing the piston so as to simulate a half-worn lining position.

12.2.1.3 Mount the test calliper assembly on a production hub and disc assembly or equivalent simulating fixture.

12.2.1.4 Place the complete fixture in an oven conforming to ISO 188 (see also Figure 1).

12.2.1.5 Connect to the actuating pressure device.

The device may be composed of a pneumatically or hydraulically actuated automotive type master cylinder, whose rate of operation shall be controlled at $(1\ 000 \pm 100)$ strokes/h.

The test fixture shall be connected to the actuating pressure device and arranged in such a manner as to yield a maximum rate-of-pressure rise of 7,0 MPa/s, and a minimum dwell period below 0,18 MPa of 0,25 s. (It may be found necessary to install a fluid accumulator, such as a standard wheel cylinder as in ISO 4928, to meet the prescribed pressure/displacement curve.)

12.2.2 Test parameters

- a) Temperature: $120\text{ °C} \pm 2\text{ °C}$.
- b) Pressure: $7,0\text{ MPa} \pm 0,3\text{ MPa}$ at a rate-of-pressure rise of $7,0\text{ MPa/s}$ max.
- c) Elapsed time: 70 h.
- d) Cycles required: $(70\ 000 \pm 5\ 000)$ cycles.

12.2.3 Precaution

12.2.3.1 After 70 h, discontinue stroking, shut off the heat, open the oven door, release hydraulic pressures in the system and allow the oven to cool for 60 min. The circulating fan may be left on to aid in cooling.

12.2.3.2 After a 60-min cooling period, remove the test assembly and allow it to cool completely in the open air for $25\text{ h} \pm 5\text{ h}$.

12.2.4 Leakage test

12.2.4.1 General

Observe for evidence of leakage during and after the 70 h stroking test. After completion of the 25-h cooling period, carry out high- and low-pressure leak tests.

12.2.4.2 High-pressure leak test

Apply $0,7\text{ MPa}$ hydraulic pressure for 5 min and observe and record leakage, if any.

12.2.4.3 Low-pressure leak test

Remove the calliper from the test stand and connect the test calliper to a pressure source at $10,0\text{ kPa} \pm 0,3\text{ kPa}$ for 24 h. Observe leakage, if any.

The low pressure source may be a static column of fluid.

NOTE A 1 200 mm column will provide 10 kPa.

12.2.4.4 Final check

Disassemble the calliper and inspect the seal. Record the visual condition of the seal, bore and piston. Seals shall not show excessive deterioration, such as scoring, scuffing, blistering, cracking, or change in shape from the original appearance.

13 Low-temperature leakage test

13.1 Test specimens

Adequate test seals for at least one complete calliper shall be prepared.

13.2 Test procedure

13.2.1 Moisten the seals and calliper bores with brake test fluid (see Clause 4). Install the test seals in the calliper.

13.2.2 Complete the test calliper assembly, placing the piston so as to simulate a new lining position. Arrangements shall be made to change the piston position during the cold test to simulate new, half, two-thirds, and full-worn lining positions.

13.2.3 Mount the test calliper assembly on a production hub and disc assembly or equivalent simulating fixture.

13.2.4 Place the test fixture in a cold chamber at $-40\text{ }^{\circ}\text{C}$ to $-43\text{ }^{\circ}\text{C}$ and connect to the pressure source as shown in Figure 2. The pressure source shall be located to provide a static reservoir head of 300 mm to 600 mm.

13.2.5 Allow the cylinder to soak for 72 h with the piston in the new lining position.

13.2.6 After 72 h, stroke the actuating mechanism six times at $1,00\text{ MPa} \pm 0,07\text{ MPa}$, followed by six times at $4,20\text{ MPa} \pm 0,35\text{ MPa}$. The strokes shall be held for approximately 5 s and applied approximately 60 s apart. Immediately after stroking, remove the first shims and, by means of the stroking mechanism, move the pistons into the half-worn lining position using minimum line pressure to establish the new location for all pistons. Observe and record leakage, if any, 30 min after the new position is established. Allow the test calliper to continue to soak for 24 h.

13.2.7 After the 96-h total soaking time, repeat step 13.2.6, except progress to the two-thirds worn lining position of the pistons.

13.2.8 After the 120-h total soaking time, repeat step 13.2.6, except progress to the full worn lining position of the pistons. Discontinue the test 30 min after establishing final piston position.

13.2.9 Disassemble the calliper and inspect the seal. Record the visual condition of the seal, bore and piston. Seals shall not show excessive deterioration, such as scoring, scuffing, blistering, cracking or change in shape from the original appearance.

13.3 Bend test procedure

13.3.1 Place one seal in a cold chamber at $-40\text{ }^{\circ}\text{C}$ to $-43\text{ }^{\circ}\text{C}$.

13.3.2 After 22 h, fold the seal back upon itself between the thumb and finger and release within 2 s to 5 s.

The cold seal shall be folded while in the cold chamber and shall be handled with cold gloves to prevent heating by the fingers.

14 Cycling humidity storage corrosion test

14.1 Test specimens

Adequate test seals for at least one complete calliper shall be prepared.

14.2 Test procedure

14.2.1 Moisten the seals and calliper with ISO fluid for corrosion storage test (see ISO 4926) or the storage corrosion test fluid agreed by the parties concerned. Install the test seals in the calliper.

14.2.2 Complete the test calliper assembly, placing the piston so as to simulate a half-worn lining position. The calliper assembly need not be assembled to a hub or test fixture as long as provisions are made to hold the pistons in their correct positions and the seals are properly installed.

14.2.3 Place the test calliper in a humidity chamber capable of maintaining $95\% \pm 2\%$ relative humidity and a temperature range of $21\text{ }^{\circ}\text{C}$ to $46\text{ }^{\circ}\text{C}$. The calliper should be placed with the inlet port open and facing down.

14.2.4 Maintain the calliper at $46\text{ }^{\circ}\text{C} \pm 2\text{ }^{\circ}\text{C}$ and $95\% \pm 2\%$ relative humidity for $16\text{ h} \pm 1\text{ h}$.

14.2.5 Change the temperature to $21\text{ }^{\circ}\text{C} \pm 2\text{ }^{\circ}\text{C}$ while maintaining $95\% \pm 2\%$ relative humidity, and maintain for $8\text{ h} \pm 1\text{ h}$.

14.2.6 Continue the above 24 h cycle for a total of 12 days. When interrupted for one or more non-working days, maintain in accordance with 14.2.5 until the temperature cycling can be resumed.

14.2.7 At the conclusion of the 12-day test, remove the test calliper for disassembly and inspection. Do not rotate the calliper and, where possible, disassemble while holding in the test position.

14.2.8 Inspect and note all components for corrosion, pitting, adhesion and other deleterious factors resulting from corrosion and/or interaction between the materials involved. Record their visual condition and any other relevant comments.

© ISO 2006 – All rights reserved

ICS 43.040.40; 83.140.50

Price based on 10 pages