**Superabrasive products — Rotating
grinding tools with diamond or cubic
boron nitride — General survey,
designation and multilingual
nomenclature**

*Produits superabrasifs — Meules rotatives à base de diamant ou de
niture de bore — Généralités, désignation et nomenclature multilingue*



Reference number
ISO 6104:2005(E)

© ISO 2005

PDF disclaimer

This PDF file may contain embedded typefaces. In accordance with Adobe's licensing policy, this file may be printed or viewed but shall not be edited unless the typefaces which are embedded are licensed to and installed on the computer performing the editing. In downloading this file, parties accept therein the responsibility of not infringing Adobe's licensing policy. The ISO Central Secretariat accepts no liability in this area.

Adobe is a trademark of Adobe Systems Incorporated.

Details of the software products used to create this PDF file can be found in the General Info relative to the file; the PDF-creation parameters were optimized for printing. Every care has been taken to ensure that the file is suitable for use by ISO member bodies. In the unlikely event that a problem relating to it is found, please inform the Central Secretariat at the address given below.

© ISO 2005

All rights reserved. Unless otherwise specified, no part of this publication may be reproduced or utilized in any form or by any means, electronic or mechanical, including photocopying and microfilm, without permission in writing from either ISO at the address below or ISO's member body in the country of the requester.

ISO copyright office
Case postale 56 • CH-1211 Geneva 20
Tel. + 41 22 749 01 11
Fax + 41 22 749 09 47
E-mail copyright@iso.org
Web www.iso.org

Published in Switzerland

Contents

Page

Foreword	iv
1 Scope	1
2 Terms and dimensional abbreviations	1
3 Designation	1
3.1 Structure of designation	1
3.1.1 Elements	1
3.1.2 Basic core shape	1
3.1.3 Shape of superabrasive section	2
3.1.4 Location of superabrasive section on core	4
3.1.5 Modification of basic core shapes	5
3.2 Complete designation	7
Annex A (informative) Dimensional abbreviations and terms	8
Annex B (informative) General survey and dimensional abbreviations	10

Foreword

ISO (the International Organization for Standardization) is a worldwide federation of national standards bodies (ISO member bodies). The work of preparing International Standards is normally carried out through ISO technical committees. Each member body interested in a subject for which a technical committee has been established has the right to be represented on that committee. International organizations, governmental and non-governmental, in liaison with ISO, also take part in the work. ISO collaborates closely with the International Electrotechnical Commission (IEC) on all matters of electrotechnical standardization.

International Standards are drafted in accordance with the rules given in the ISO/IEC Directives, Part 2.

The main task of technical committees is to prepare International Standards. Draft International Standards adopted by the technical committees are circulated to the member bodies for voting. Publication as an International Standard requires approval by at least 75 % of the member bodies casting a vote.

Attention is drawn to the possibility that some of the elements of this document may be the subject of patent rights. ISO shall not be held responsible for identifying any or all such patent rights.

ISO 6104 was prepared by Technical Committee ISO/TC 29, *Small tools*, Subcommittee SC 5, *Grinding wheels and abrasives*.

This second edition cancels and replaces the first edition (ISO 6104:1979), which been technically revised.

Superabrasive products — Rotating grinding tools with diamond or cubic boron nitride — General survey, designation and multilingual nomenclature

1 Scope

This International Standard gives a general survey, and specifies the designation, of rotating grinding tools with diamond or cubic boron nitride superabrasive section. It also gives a multilingual nomenclature concerning these tools.

NOTE In addition to terms in English and French, two of the three official ISO languages, this International Standard gives the equivalent terms in German; these terms are published under the responsibility of the member body for Germany (DIN). However, only the terms given in the official language can be considered as ISO terms.

2 Terms and dimensional abbreviations

See Annex A.

3 Designation

3.1 Structure of designation

3.1.1 Elements

The structure of designation comprises three symbols intended only for the designation of the rotating grinding wheel and cutting-off wheels (saws). The three symbols shall be included in any designation. A supplementary symbol may be used if necessary.

The meaning of these symbols is the following:

- digit or characteristic number for the basic core shape on which the superabrasive section is mounted (see 3.1.2);
- one- or two-letter symbols for the shape or superabrasive section (see 3.1.3);
- digit or characteristic number for location of the superabrasive section on the core (see 3.1.4);
- possibly, one or several letter symbols for the core modifications (see 3.1.5).

3.1.2 Basic core shape

Basic core shapes are defined by symbols irrespective of their location of the superabrasive section on the core and the end use of the rotating grinding tools. The presence of a recess in the core to accommodate the superabrasive section does not affect the determination of the symbol. For basic core shapes, see Table 1.

Table 1 — Basic core shapes













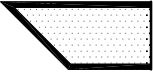
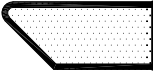

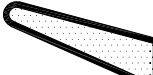
Core shape	Designation	Illustration	Core shape	Designation	Illustration
1	Straight peripheral wheel		10	Concave double-angle cup wheel	
2	Face or rim wheel		11	Taper cup wheel	
3	Single hubbed wheel		12	Taper cup wheel	
4	Wheel tapered one side		13	Taper cup wheel	
6	Straight cup wheel		14	Double hubbed wheel	
9	Double cup wheel				—

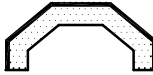
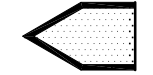
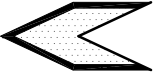
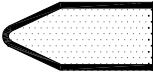
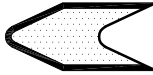
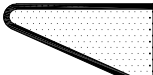
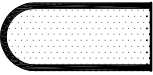
3.1.3 Shape of superabrasive section

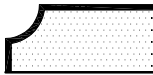
Superabrasive section shapes and their codes are shown and indicated in Table 2.

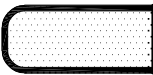
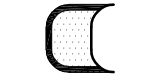
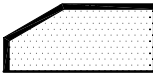
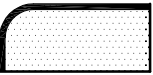
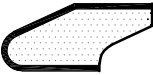
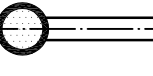
- Code is irrespective of the location of the superabrasive section.
- The superabrasive section can be at any position relative to the core.
- The bold black lines in the drawings indicate the grinding face.

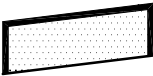
Table 2 — Superabrasive section shapes and codes

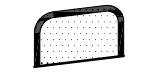
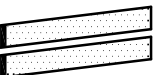
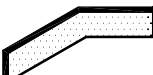
A 	AA 	B 	BF 
BH 	BT 	C 	D 
DD 	E 	EE 	EF 
EH 	ET 	F 	FF 
G 	J 	K 	L 
LL 	M 	Q 	QV 
R 	S 	U 	V 
VF 	VL 	VV 	Y 
NOTE The most common shapes are shown.			

3.1.4 Location of superabrasive section on core

See Table 3.

Table 3 — Location of the superabrasive section on the core

No.	Location	Description	Shape
1	Periphery	The superabrasive section is placed on the periphery of the core and extends over the full thickness of the wheel. The axial length of this section may be greater than, equal to, or less than the depth of diamond or CBN, measured radially. One or more hubs are not added to the wheel thickness for the purpose of this description.	
2	One side	The superabrasive section is placed on the side of the wheel and the length of the superabrasive section extends from the periphery towards the centre. It may or may not include the entire side.	
3	Both sides	The superabrasive sections are placed on both sides of the wheel and extend from the periphery towards the centre. They may or may not include the entire sides.	
4	Concave or arc	This description applies to the general wheel types 2, 6, 10, 11, 12 or 13, and locates the superabrasive section on the side wall. This wall has an angle or arc extending from a higher point at the wheel periphery to a lower point towards the wheel centre.	
5	Convex or arc	This description applies to the general wheel types 2, 6 and 11, and locates the superabrasive section on the side wall. This wall has an angle or arc extending from a lower point at the wheel periphery to a higher point toward the wheel centre.	
6	Part of periphery	The superabrasive section is placed on the periphery of the core but does not extend over the full thickness of the wheel and does not reach to either side.	
7	Part of side	The superabrasive section is placed on the side of the core and does not extend to the wheel periphery. It may or may not extend to the centre.	
8	Throughout	No core, superabrasive wheel consists of solid superabrasive section.	

Table 3 (continued)

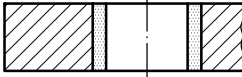
No.	Location	Description	Shape
9	Corner	This description is of a location which would commonly be considered to be on the periphery, except that the superabrasive section is on one corner but does not extend to the other corner.	
10	Annular	This description is of a location of the superabrasive section on the inner annular of the wheel.	

3.1.5 Modification of basic core shapes

Modifications that are made to basic core shapes are optional within the meaning of the descriptions given in Table 4.

Table 4 — Modification to basic core shapes



Abbreviation	Description	Shape
B	Holes drilled and counterbored in core	
C	Holes drilled and countersunk in core	
H	Straight holes drilled in core	
K	Hole with keyway in core	
M	Mixed holes, some plain, some threaded, in the core	

Table 4 (continued)

Abbreviation	Description	Shape
P	Relief on one side of the wheel, thickness of core less than wheel thickness	
Q	Three surfaces of superabrasive section partially or wholly enclosed by the core	
R	Relief on both sides of superabrasive wheel. The thickness of the core is less than the wheel thickness.	
S	The cutting off wheel (saw) has a section which is interrupted by grooves and applied to a core with solid rim (clearance between segments has no bearing on definition).	
SS	The cutting-off wheel (saw), with segments mounted on solid and slotted core rim	
T	Threaded holes in core	
V	The superabrasive cross section is considered inverted if mounted on the core so that the interior point of any angle or the concave side of any arc is exposed.	
W	Superabrasive section core and mounting shaft cannot be dismantled	
Y	See descriptions for Q and V.	

3.2 Complete designation

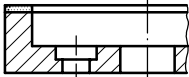
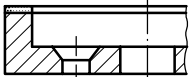
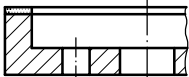
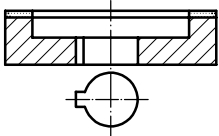
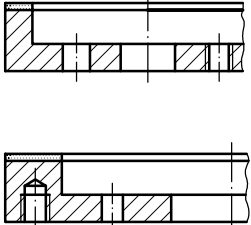
The complete designation of rotating grinding wheels with diamond or cubic boron nitride shall comprise the following indications in the order given:

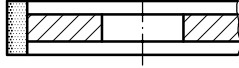
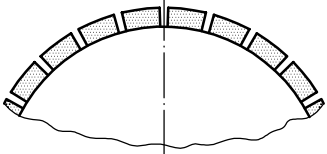
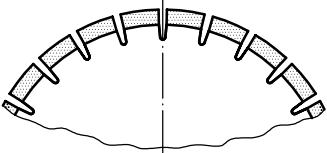
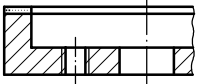
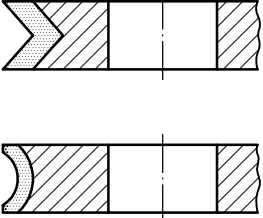
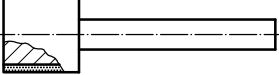
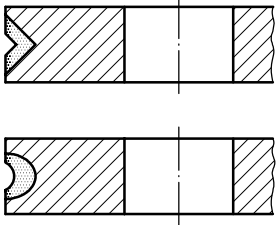
- a) designation of the rotating grinding wheel corresponding to Table 1 and Annex B;
- b) number block corresponding of this International Standard, i.e. ISO 6104;
- c) basic core shape, in accordance with 3.1.2;
- d) shape of the superabrasive section, in accordance with 3.1.3;
- e) location of superabrasive section on the core, in accordance with 3.1.4;
- f) any modification(s) carried out to the basic core shapes, in accordance with 3.1.5;
- g) nominal dimensions provided by the manufacturer.

EXAMPLE

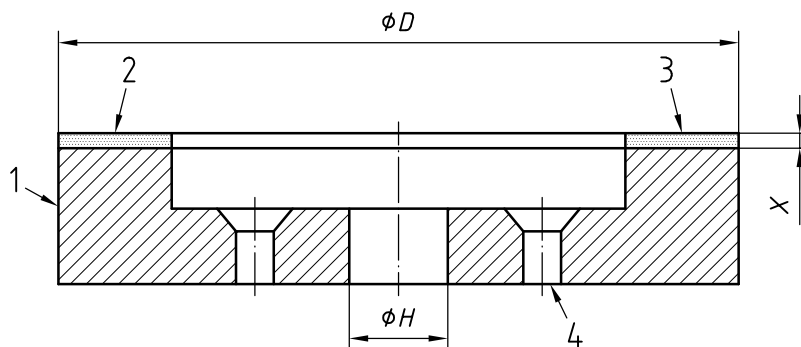

Key

- 1 core shape
- 2 shape of diamond or CBN section
- 3 location of diamond or CBN section
- 4 modification (drilled and countersunk hole)

Straight cup wheel ISO 6104 6 A 2 C - 125 × 15 × 2 × 20

Straight cup wheel

ISO number block

Basic core shape

Shape of the superabrasive section

Location of the superabrasive section

Modification (drilled and countersunk hole)

Outside diameter

Rim width

Depth of superabrasive section

Bore diameter

Annex A (informative)

Dimensional abbreviations and terms

Table A.1 — Dimensional abbreviations and terms
[in English (en), French (fr) and German (de)]

Symbol	Language Langue Sprache	Term Terme Benennung
<i>D</i>	en	Outside diameter
	fr	Diamètre extérieur
	de	Außendurchmesser
<i>E</i>	en	Thickness of a wheel, dish wheel and a recessed or relieved wheel, thickness of a blank
	fr	Épaisseur de meule, meule assiette et meule à embrèvement ou à dépouille, épaisseur de l'âme
	de	Bodendicke von Schleiftöpfen und –tellern sowie ausgesparten und verjüngten Schleifscheiben, Dicke des Stammblattes
<i>H</i>	en	Bore diameter
	fr	Diamètre de l'alésage
	de	Bohrungsdurchmesser
<i>J</i>	en	Smallest diameter of tapered cup, dish or tapered wheel
	fr	Petit diamètre des meules boisseaux coniques, des meules assiettes ou des meules coniques
	de	Kleinerer Durchmesser bei kegeligen Schleiftöpfen, Schleiftellern, konischen und abgesetzten Schleifscheiben
<i>K</i>	en	Internal diameter of recess on tapered cup or dish wheel
	fr	Diamètre intérieur de l'embrèvement des meules boisseaux coniques ou des meules assiettes
	de	Innendurchmesser von kegeligen Schleiftöpfen und Schleiftellern, Durchmesser der Verjüngung von Schleifscheiben
<i>L</i>	en	Overall length of mounted point
	fr	Longueur hors tout de la meule sur tige
	de	Gesamtlänge bei Schleifstiften
<i>L₁</i>	en	Length of segment, spindle length of mounted point
	fr	Longueur de segment, longueur de la tige de la meule sur tige
	de	Länge des Schleifsegmentes, Schaftlänge bei Schleifstiften
<i>L₄</i>	en	Reduced length of spindle of mounted point
	fr	Longueur de la tige décollétée de la meule sur tige
	de	Länge der Absetzung des Schaftes bei Schleifstiften

Table A.1 (continued)

Symbol	Language Langue Sprache	Term Terme Benennung
R	en	Radius
	fr	Rayon
	de	Radius
S_d	en	Spindle diameter of mounted point
	fr	Diamètre de la tige de la meule sur tige
	de	Schaftdurchmesser bei Schleifstiften
S_1	en	Diameter of reduced spindle of mounted point
	fr	Diamètre de la tige décollétée de la meule sur tige
	de	Durchmesser der Absetzung bei Schleifstiften
T	en	Overall thickness
	fr	Épaisseur hors tout
	de	Gesamtbreite
U	en	Thickness of superabrasive section (if less than T or T_1)
	fr	Épaisseur de la couche abrasive (si inférieure à T ou à T_1)
	de	Belagbreite (wenn kleiner als T oder T_1)
W	en	Rim width
	fr	Largeur de la partie travaillante
	de	Schleifrandbreite
X	en	Useable depth of superabrasive section
	fr	Profondeur de la couche abrasive
	de	Nutzbare Schleifbelagdicke
X_1	en	Overall depth section
	fr	Profondeur hors tout de la couche abrasive
	de	Gesamtschleifbelagdicke
α	en	Angle with the body of guiding wheel
	fr	Angle avec le corps de meule de guidage
	de	Grundkörperwinkel
β	en	Offset basic core angle
	fr	Angle d'alésage de base du déport
	de	Abgesetzter Grundkörperwinkel

Annex B
(informative)

General survey and dimensional abbreviations

Examples of grinding wheels and mounted points are given in Tables B.1 and B.2

Table B.1 — Examples of grinding wheels

Core shape	Sketch	Core shape	Sketch
1A1		10A2	
1A1R		11A2	
1A8		11VV2	
1V1		11V9	
3A1		12A2	
4A2		12V9	
4BT9		13A2	
4V2		14A1	
6A2		14AA1	
6AA2		14E1	
6A9		14F1	

Table B.1 (continued)





Core shape	Sketch	Core shape	Sketch
6A10		14FF1	
9A3		14FF6Y	

Table B.2 — Examples of mounted points

Core shape	Sketch	Core shape	Sketch
1A1W		1K1W	
1A1PW		1R1W	
1D1W		1T1W	
1E1W		1U1W	
1F1W		1V1W	
1G1W		11V2W	

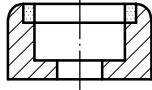
ICS 25.100.70

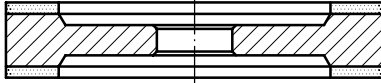
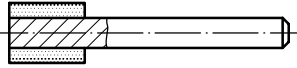
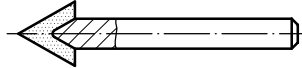
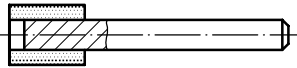
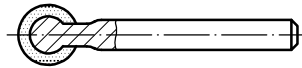
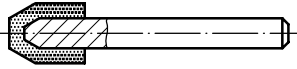
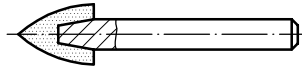
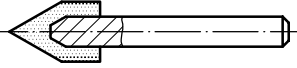
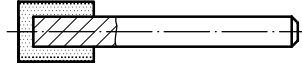
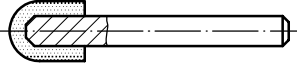
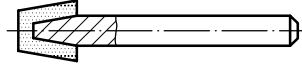
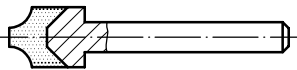
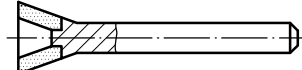
Price based on 11 pages