Industrial trucks — Overhead guards — Specification and testing

*Chariots de manutention — Protège-conducteurs — Spécifications et
essais*



Reference number
ISO 6055:2004(E)

© ISO 2004

PDF disclaimer

This PDF file may contain embedded typefaces. In accordance with Adobe's licensing policy, this file may be printed or viewed but shall not be edited unless the typefaces which are embedded are licensed to and installed on the computer performing the editing. In downloading this file, parties accept therein the responsibility of not infringing Adobe's licensing policy. The ISO Central Secretariat accepts no liability in this area.

Adobe is a trademark of Adobe Systems Incorporated.

Details of the software products used to create this PDF file can be found in the General Info relative to the file; the PDF-creation parameters were optimized for printing. Every care has been taken to ensure that the file is suitable for use by ISO member bodies. In the unlikely event that a problem relating to it is found, please inform the Central Secretariat at the address given below.

© ISO 2004

All rights reserved. Unless otherwise specified, no part of this publication may be reproduced or utilized in any form or by any means, electronic or mechanical, including photocopying and microfilm, without permission in writing from either ISO at the address below or ISO's member body in the country of the requester.

ISO copyright office
Case postale 56 • CH-1211 Geneva 20
Tel. + 41 22 749 01 11
Fax + 41 22 749 09 47
E-mail copyright@iso.org
Web www.iso.org

Published in Switzerland

Contents

	Page
1 Scope	1
2 Normative references	1
3 Requirements for high lift rider trucks with lift height exceeding 1 800 mm	1
3.1 Introduction	1
3.2 General	1
3.3 Dimensions	2
3.4 Testing	6
3.4.1 General	6
3.4.2 Dynamic test	6
3.4.3 Impact drop test	6
3.4.4 Operators' legs and feet protection test	7
3.5 Performance requirements	7
4 Requirements for variable reach trucks with operator position not protected by the boom	9
4.1 Introduction	9
4.2 General	9
4.3 Dimensions	9
4.4 Testing	10
4.4.1 General	10
4.4.2 Falling objects test	10
4.4.3 Overturning test	10
4.5 Performance requirements	10
Bibliography	11

Foreword

ISO (the International Organization for Standardization) is a worldwide federation of national standards bodies (ISO member bodies). The work of preparing International Standards is normally carried out through ISO technical committees. Each member body interested in a subject for which a technical committee has been established has the right to be represented on that committee. International organizations, governmental and non-governmental, in liaison with ISO, also take part in the work. ISO collaborates closely with the International Electrotechnical Commission (IEC) on all matters of electrotechnical standardization.

International Standards are drafted in accordance with the rules given in the ISO/IEC Directives, Part 2.

The main task of technical committees is to prepare International Standards. Draft International Standards adopted by the technical committees are circulated to the member bodies for voting. Publication as an International Standard requires approval by at least 75 % of the member bodies casting a vote.

Attention is drawn to the possibility that some of the elements of this document may be the subject of patent rights. ISO shall not be held responsible for identifying any or all such patent rights.

ISO 6055 was prepared by Technical Committee ISO/TC 110, *Industrial trucks*, Subcommittee SC 2, *Safety of powered industrial trucks*.

This third edition cancels and replaces the second edition (ISO 6055:1997), it includes the contents of ISO 6055:1997 with the exception of the option for order picking trucks.

The following requirements have been added:

- impact drop testing;
- capability to add a fitting to protect against small falling objects;
- requirements for variable reach rough terrain trucks.

Industrial trucks — Overhead guards — Specification and testing

1 Scope

This International Standard specifies the requirements and testing of overhead guards, operators' legs and feet protection, roll-over protection system (ROPS) and falling-object protection system (FOPS) for any type of high lift, rider operated, powered industrial truck with a lift height exceeding 1 800 mm.

2 Normative references

The following referenced documents are indispensable for the application of this document. For dated references, only the edition cited applies. For undated references, the latest edition of the referenced document (including any amendments) applies.

ISO 3164, *Earth-moving machinery — Laboratory evaluations of protective structures — Specifications for deflection-limiting volume*

ISO 3449, *Earth-moving machinery — Falling-object protective structures — Laboratory tests and performance requirements*

ISO 3471, *Earth-moving machinery — Roll-over protective structures — Laboratory tests and performance requirements*

ISO 3691, *Powered industrial trucks — Safety code*

ISO 5353, *Earth-moving machinery, and tractors and machinery for agriculture and forestry — Seat index point*

ISO 13564-1, *Powered industrial trucks — Test methods for verification of visibility — Part 1: Sit-on and stand-on operator trucks and variable reach trucks*

3 Requirements for high lift rider trucks with lift height exceeding 1 800 mm

3.1 Introduction

This section applies to trucks fitted with masts and variable reach trucks where the operator position is protected by the boom, i.e. the mast or boom prevents the truck from tipping more than a nominal 90°.

3.2 General

3.2.1 The overhead guard shall extend over the operator when in the normal operating position(s) as defined in ISO 3691 and when the operator is operating the controls as provided by the truck manufacturer. For overhead guards fixed to the mast, this also applies when the mast is inclined.

The control levers in their neutral position, the pedals in their released condition and the steering wheel are considered protected if they do not project in the direction of the mast more than 150 mm beyond the vertical projection of the outline of the overhead guard onto a horizontal plane; see Figure 1. Adjustable steering wheels for the driving mode shall be placed in the centre position. No account is taken of the parking brake lever in its foremost position in relation to the mast.

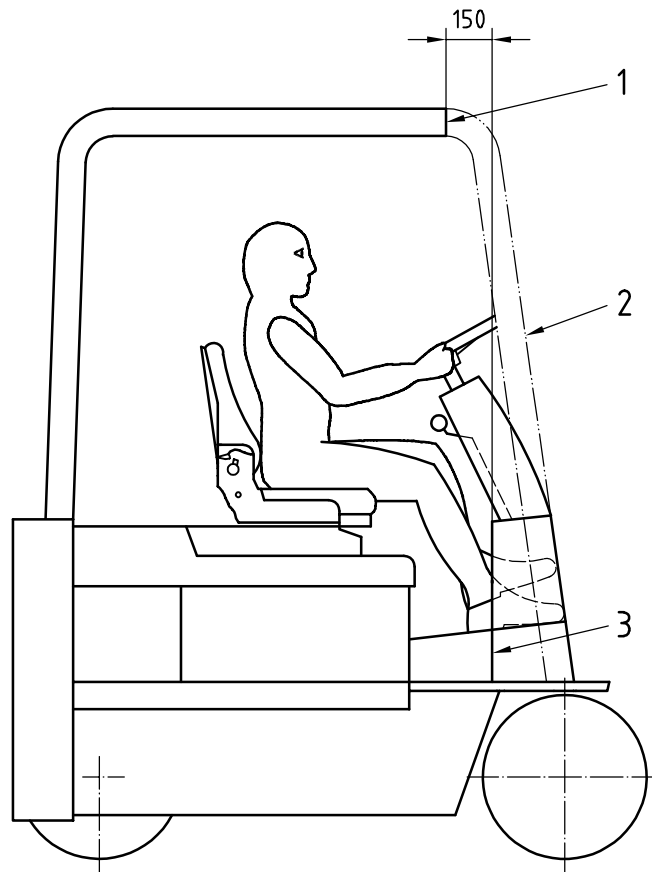

Key

- 1 edge of overhead guard
- 2 phantom view of front support
- 3 rear of forward structure

Figure 1 — Satisfactory protection by the overhead guard

Any part of the operator's legs or feet, in the normal operating position, that project more than 150 mm beyond the front of the overhead guard when vertically projected onto a horizontal plane, shall be protected by a structure. The test procedure for the structure is described in 3.4.4.

3.2.2 Failure of the tilting mechanism must not, directly or indirectly, cause the operator to be in danger because of the overhead guard.

3.3 Dimensions

3.3.1 The guard shall be constructed in a manner that does not interfere with the visibility, as specified in ISO 13564-1.

3.3.2 Openings in the top of the overhead guard shall not exceed 150 mm in one of the two dimensions, i.e. width or length.

3.3.3 For high-lift trucks on which the operator is seated, the vertical clearance, from the seat index point in accordance with ISO 5353 to the underside of the section of the overhead guard under which the operator's head is located when the operator is in the normal operating position, shall not be less than 903 mm.

3.3.4 For high-lift trucks on which the operator stands, the vertical clearance, from the platform where the operator stands to the underside of the section of the overhead guard under which the operator's head is located when the operator is in the normal operating position, shall not be less than 1 880 mm.

3.3.5 When requested by the user, the manufacturer may reduce the normal overall overhead guard height and vertical clearance for the operator's head under the overhead guard to permit operation of the truck with an overhead guard in areas where the overhead clearance limits the overall height of the truck.

For example, if the torso height of the 95th percentile is XX as defined in Figures 1 to 4 of ISO 3411:1995^[1] and the overhead guard height is reduced by Y , then the recommended torso height for operators should not exceed $XX - Y$.

Where there is reduced vertical clearance, information shall be provided with the overhead guard specifying any limits associated with the height of operators who may use trucks on which the guard is fitted.

3.3.6 Where the manufacturer of the overhead guard has been informed that the user may be at risk from falling objects which could pass through the 150 mm opening (see 3.3.2), then the guard shall be constructed to remove that risk, with the opening set as necessary based upon the information supplied.

Dimensions in millimetres

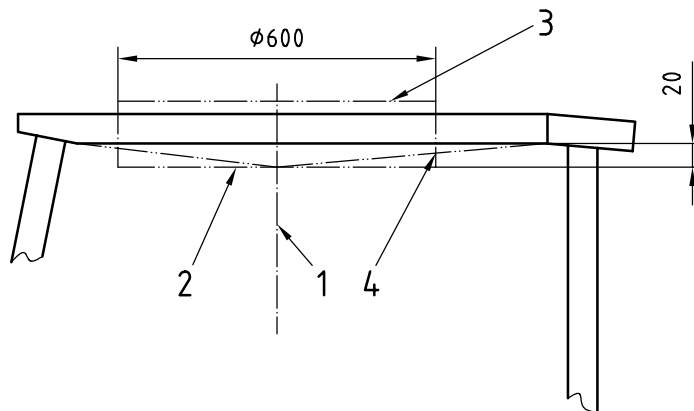

Key

- 1 centre of the operator's standing position or seat index point with the seat at its midpoint of adjustment
- 2 deformation limiting line [$(L - 20)$ mm max.]
- 3 measuring area of deformation
- 4 deformed underside

Figure 2 — Dynamic test permissible deformation — Overhead guard supported on all sides

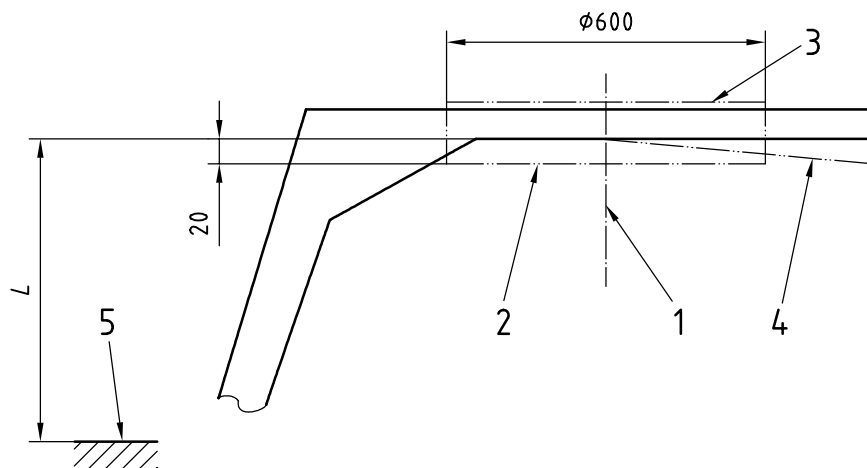

Key

- 1 centre of the operator's standing position or seat index point with the seat at its midpoint of adjustment
- 2 deformation limiting line [$(L - 20)$ mm max.]
- 3 measuring area of deformation
- 4 deformed underside
- 5 base line relative to chassis

Figure 3 — Dynamic test permissible deformation — Overhead guard supported on one side only

Dimensions in millimetres

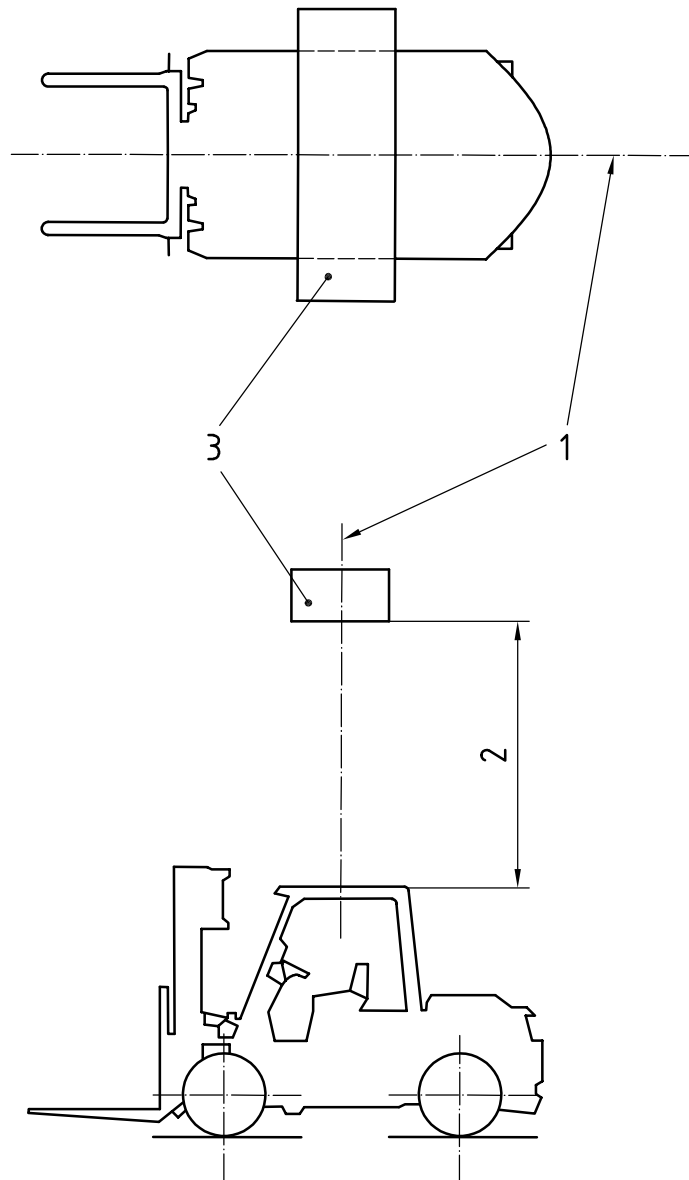

Key

- 1 centreline of truck and test load
- 2 drop height; see Table 1
- 3 test load

Figure 4 — Impact test method

3.4 Testing

3.4.1 General

3.4.1.1 A dynamic and an impact drop test shall be carried out on a guard fitted to a truck of the type and rated capacity for which it has been designed. Alternatively, the guard may be mounted on a test chassis provided that the mounting is the same as that on the truck for which it was designed.

3.4.1.2 The same overhead guard and mounting shall be used for both tests. The dynamic test, as described in 3.4.2, shall be conducted first, followed by the impact drop test, as described in 3.4.3.

3.4.1.3 In the case of specially designed overhead guards fitted to trucks, other means, such as calculation methods that have been verified through tests on comparable guards, may be used to determine compliance with the requirements.

3.4.1.4 For trucks with an elevating operator position and an auxiliary lifting equipment with a lift height up to and including 1 800 mm in relation to the operator platform, the impact test is not required.

3.4.2 Dynamic test

3.4.2.1 The purpose of this test is to determine the resistance to permanent deflection of the portion of the overhead guard under which the operator sits or stands.

NOTE In the case of overhead guards fitted to trucks of special design, other means, such as computation or prior test results, may be used to determine compliance with the requirements.

3.4.2.2 The test object shall be a mass of 45 kg having a square striking face with a side dimension of 300 mm. The striking face shall be of oak wood or material of a similar density and at least 50 mm thick. The corners and edges shall have a radius of 10^{+5}_0 mm.

3.4.2.3 The test object shall be positioned to drop in free fall with the striking face approximately parallel to the top of the overhead guard, so as not to strike with a corner or an edge. The test object shall be dropped a distance of 1,5 m 10 times. The first drop shall be from a point with the centre of the test object vertically above the seat index point of the operator's seat in accordance with ISO 5353, with the seat in its mid-point of adjustment, or above the centre of the standing position. The other 9 drops shall be in a clockwise direction from points with the centre of the test object equally spaced on a 600 mm diameter circle, the centre point of which is vertically above the seat index point of the operator's seat, in its mid point of adjustment, or above the centre of the standing position. The first of the nine drops to be from a point at the front of the overhead guard.

NOTE It is recognized that in some positions a portion of the test object may overlap the edge of the overhead guard when striking.

3.4.3 Impact drop test

3.4.3.1 The purpose of this test is to determine the permanent deformation of the overhead guard if struck by a large load, e.g. packaged timber, paper reels.

3.4.3.2 The test load shall be composed of 50 mm × 100 mm nominal construction grade timber boards, 3 600 mm long; the complete test load shall not exceed 1 000 mm in width. The 50 mm × 100 mm shall be placed with the 100 mm nominal dimension of the cross section horizontal. The timber shall be bound together with at least three metal bands, one approximately in the centre and the others not further than 900 mm from each end.

The test load shall have a minimum mass as specified in Table 1.

A test load of different dimensions and/or materials may be used, provided it results in a test not less severe than that described above.

Table 1 — Overhead guard impact test loads

Truck rated capacity kg	Impact test energy E_{test} ^a J	Minimum mass of test load kg
Under 1 000	3 600	340
1 000 to 1 500	5 400	340
1 501 to 2 500	10 800	680
2 501 to 3 500	21 760	1 360
3 501 to 6 500	32 640	1 360
6 501 to 10 000	43 520	1 360
Over 10 000	48 960	1 360

$$^a l_{\text{drop}} = E_{\text{test}} / (9,8 \times m_{\text{test}})$$

where

l_{drop} is the drop distance, in metres;

m_{test} is the actual mass of the test load, in kilograms.

3.4.3.3 The test load shall be centred above the overhead guard with the 3 600 mm length at right angles to the longitudinal centre line of the truck, the 1 000 mm flat shall strike the guard in this position (see Figure 4).

3.4.3.4 The test load shall be dropped in free fall from an approximately horizontal position and from a height to develop the required impact, in joules, specified in Table 1.

3.4.4 Operators' legs and feet protection test

3.4.4.1 The purpose of this test is to verify the strength of the structure providing protection to the operator's feet and legs. See 3.2.1.

3.4.4.2 The test object, as specified in 3.4.2.2, shall be positioned above the centre of each set of pedals and dropped in free fall from a height of 1,5 m to strike the protection structure. The test object shall be dropped once above each set of pedals.

To provide a clear drop for the purposes of this test, any adjacent components, e.g. overhead guard, mast, steering column, or components mounted on the protection structure, e.g. hydraulic control levers, brake lever, shall be removed.

If, by design, the removal of these structural components results in a detriment to the strength of the structure, the components shall be left on the test vehicle and the test shall be conducted with the test object being dropped along the vertical line of the overhead guard.

3.5 Performance requirements

3.5.1 Following the tests described in 3.4.2, the structural parts of the overhead guard and its mountings shall not show fracture, parts separation or permanent vertical deformation exceeding 20 mm, measured on the underside of the overhead guard within a 600 mm diameter circle, the centre point of which is vertically above the seat index point of the operators seat, in the mid-point of adjustment or vertically above the centre point of the operator in the standing position (see Figures 2 and 3). Failure, during the dynamic test, of material fitted across the openings permitted in 3.3.2, such as wire mesh, toughened glass, transparent panel, etc., shall be ignored.

3.5.2 Following the tests described in 3.4.3, the permanent deformation of the overhead guard and its mounting after impact shall leave a minimum distance of

- a) for sit down rider trucks, 250 mm between the horizontal plane tangential to the underside of the overhead guard at the operators position and a horizontal plane tangential to the upper surface of the steering wheel (see Figure 5);
- b) for stand on rider trucks, 1 600 mm between the horizontal plane tangential to the underside of the overhead guard at the operators position and the surface on which the operator stands during truck operation (see Figure 6).

3.5.3 Following the test described in 3.4.4, the foot protection structure shall not approach closer than 150 mm measured vertically above the highest point of any of the pedals (see Figure 7).

Dimensions in millimetres

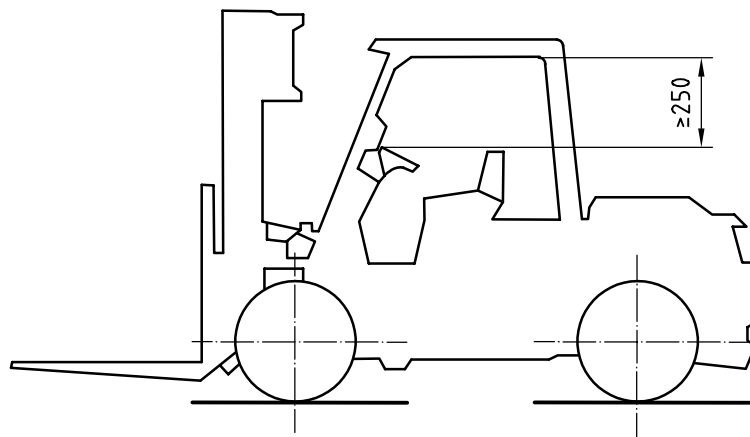

Figure 5 — Impact test permitted deformation — Seated operator truck

Dimensions in millimetres

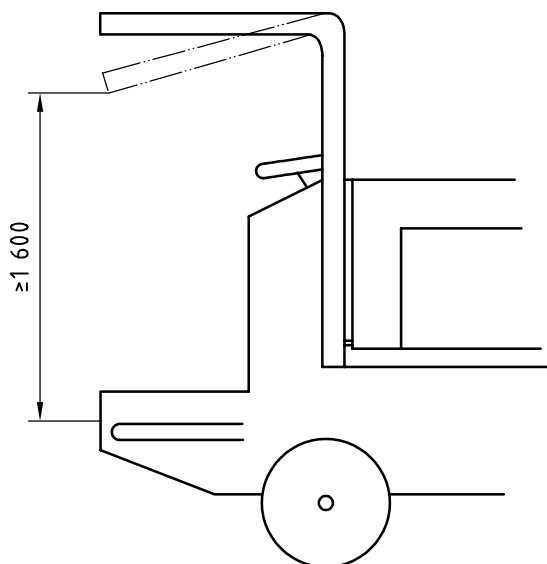

Figure 6 — Impact test permitted deformation — Standing operator truck

Dimensions in millimetres

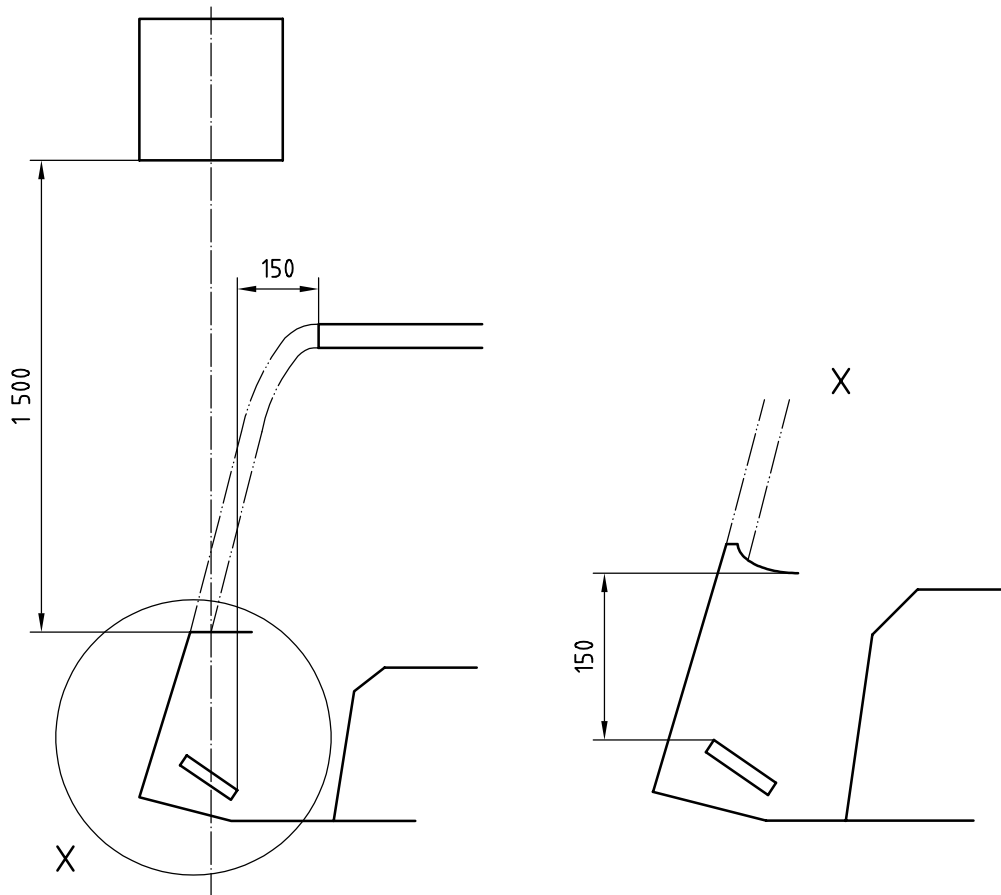

Figure 7 — Leg and foot protection clearance

4 Requirements for variable reach trucks with operator position not protected by the boom

4.1 Introduction

This section applies to all variable reach trucks except those where the operator position is protected by the boom.

4.2 General

Trucks shall be fitted with protective structures which protect the operator not only against falling objects but also against risks in the event of rollover.

4.3 Dimensions

The protective structure shall comply with the requirements of 3.2.1, 3.3.1, 3.3.2 and 3.3.6.

4.4 Testing

4.4.1 General

The test shall be carried out without the boom fitted to the truck.

4.4.2 Falling objects test

Variable-reach trucks shall be equipped with a FOPS, except if they are intended only for handling freight containers with spreader. The FOPS shall comply with ISO 3449.

If the maximum value of the product of the actual capacity, in kilograms, with the corresponding maximum lift height in metres, is $\geq 10\,000$ kg·m, FOPS shall be of level II.

If the maximum value of the product is $< 10\,000$ kg·m, FOPS can be of level I.

The tests shall be carried out in such manner that the boom of the truck does not interfere or participate in the test.

4.4.3 Overturning test

The truck with its protective structure shall be tested in accordance with ISO 3471, as specified for wheeled loaders.

4.5 Performance requirements

The deflection-limiting volume after tests of resistance against falling objects and overturning shall comply with the requirements of ISO 3164.

Bibliography

- [1] ISO 3411:1995, *Earth-moving machinery — Human physical dimensions of operators and minimum operator space envelope*

www.iso.org

ICS 53.060

Price based on 11 pages