

INTERNATIONAL  
STANDARD

**ISO**  
**6038**

Second edition  
1993-04-15

---

---

**Cinematography — Splices for use on  
70 mm, 65 mm, 35 mm and 16 mm  
motion-picture films — Dimensions and  
locations**

*Cinématographie — Raccords sur films cinématographiques 70 mm,  
65 mm, 35 mm et 16 mm — Dimensions et emplacements*



Reference number  
ISO 6038:1993(E)

## Foreword

ISO (the International Organization for Standardization) is a worldwide federation of national standards bodies (ISO member bodies). The work of preparing International Standards is normally carried out through ISO technical committees. Each member body interested in a subject for which a technical committee has been established has the right to be represented on that committee. International organizations, governmental and non-governmental, in liaison with ISO, also take part in the work. ISO collaborates closely with the International Electrotechnical Commission (IEC) on all matters of electrotechnical standardization.

Draft International Standards adopted by the technical committees are circulated to the member bodies for voting. Publication as an International Standard requires approval by at least 75 % of the member bodies casting a vote.

International Standard ISO 6038 was prepared by Technical Committee ISO/TC 36, *Cinematography*.

This second edition cancels and replaces the first edition (ISO 6038:1985), of which it constitutes a technical revision.

Annex A of this International Standard is for information only.

© ISO 1993

All rights reserved. No part of this publication may be reproduced or utilized in any form or by any means, electronic or mechanical, including photocopying and microfilm, without permission in writing from the publisher.

International Organization for Standardization  
Case Postale 56 • CH-1211 Genève 20 • Switzerland

Printed in Switzerland

# Cinematography — Splices for use on 70 mm, 65 mm, 35 mm and 16 mm motion-picture films — Dimensions and locations

## 1 Scope

**1.1** This International Standard specifies the dimensions and locations of transverse cemented or welded overlap splices and butt splices on 70 mm, 65 mm, 35 mm and 16 mm motion-picture films and prints with magnetic or photographic sound records.

**1.2** The following types are specified:

- a) Type 1 — Laboratory type, overlap splice intended for negatives and intermediate films, perforated short pitch;
- b) Type 2 — Projection type, overlap splice intended for prints with non-anamorphic type picture;
- c) Type 3 — Projection type, overlap splice intended for prints with anamorphic type picture;
- d) Type 4 — Projection type, overlap splice made with transparent adhesive tape and intended for prints;
- e) Type 5 — Projection type specialized uses, butt splice made with transparent tape and intended for prints.

## 2 Dimensions

**2.1** The dimensions specified in tables 1 to 5 apply to motion-picture films which contain nominal shrinkage up to 0,2 %, and recently made splices.

**2.2** The dimensions of cemented or welded overlap splices for 16 mm motion-picture films shall be as shown in figures 1, 2 and 5 and as given in tables 1 and 5.

**2.3** The dimensions of butt splices shall be in accordance with the dimensions *B* and *E* as specified in tables 1 to 5.

**2.4** The dimensions for 70 mm, 65 mm and 35 mm motion-picture films shall be as shown in figures 3 to 5 and as given in tables 2 to 5.

**2.5** The film width at the splice shall not exceed

- 70,05 mm (2,758 in) for 70 mm films;
- 65,05 mm (2,561 in) for 65 mm films;
- 35,03 mm (1,379 in) for 35 mm films;
- 16,00 mm (0,630 in) for 16 mm films.

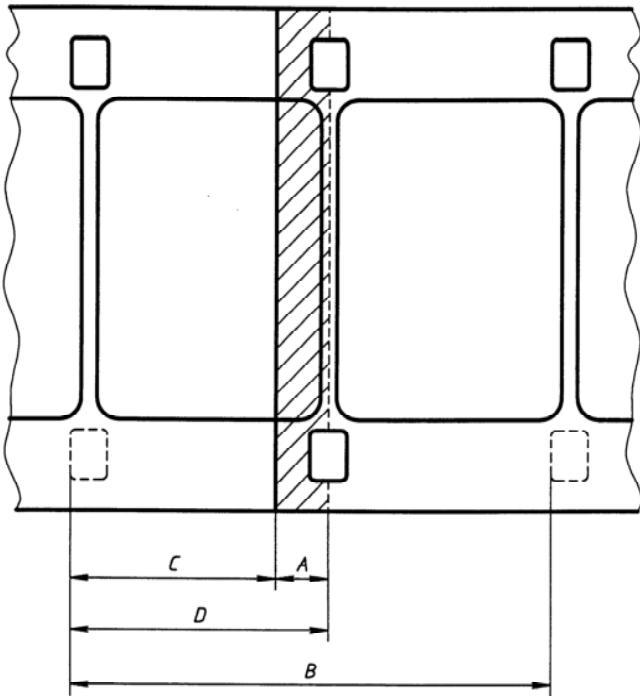

Figure 1 — Splices on 16 mm film laboratory type

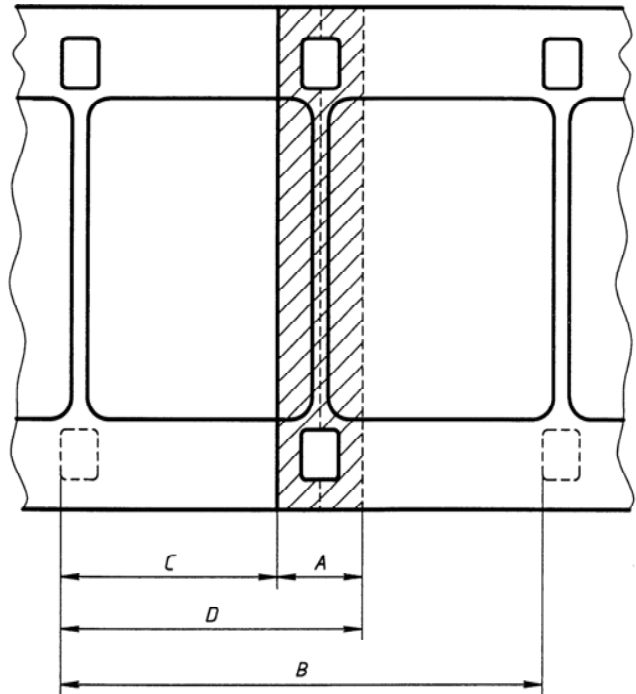

Figure 2 — Splices on 16 mm film projection type

Table 1 — Dimensions of splices for 16 mm motion-picture films

Dimension	Type 1 (laboratory) <sup>1)</sup>		Type 2 (projection)	
	mm	in	mm	in
A nom.	1,76	0,069	2,49	0,098
B	15,21 ± 0,05	0,599 ± 0,002	15,24 ± 0,05	0,600 ± 0,002
C	6,47 ± 0,05	0,255 ± 0,002	7,01 ± 0,10	0,276 ± 0,004
D	8,23 ± 0,05	0,324 ± 0,002	9,50 ± 0,10	0,374 ± 0,004

1) In single negative printing, dimension C should be 7,53 mm ± 0,05 mm (0,296 in ± 0,002 in) to minimize the possibility of printing of a white line. Dimension A becomes 0,70 mm (0,028 in).

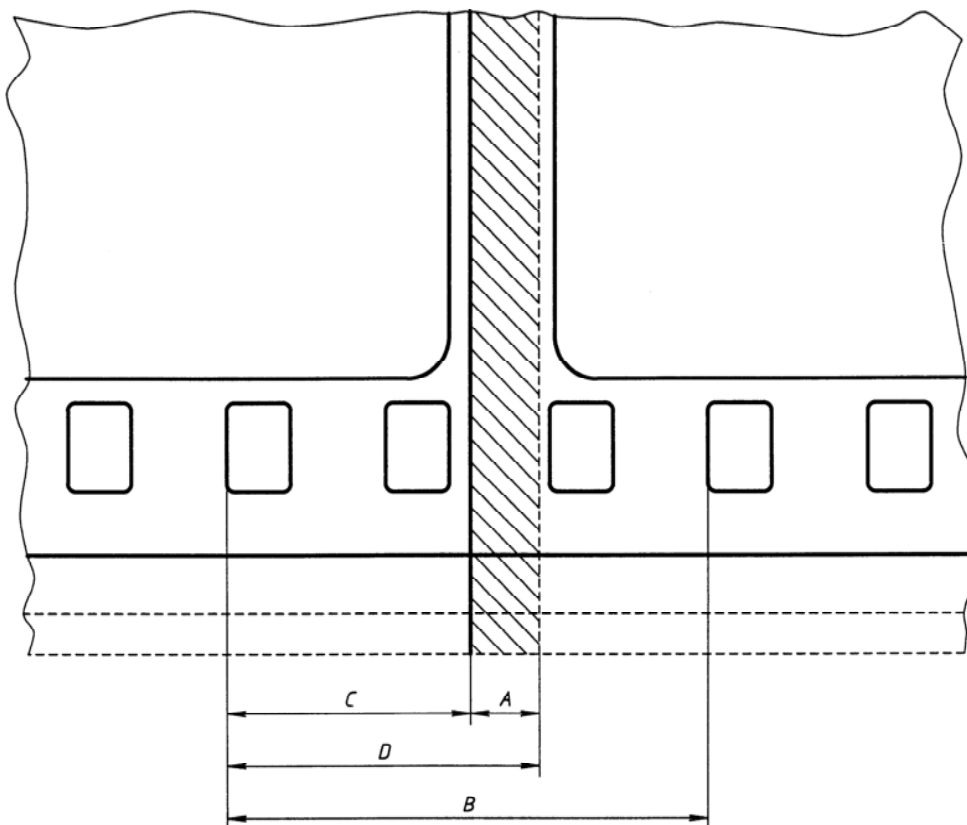

Figure 3 — Splices on 70 mm, 65 mm and 35 mm films

Table 2 — Dimensions of splices for 35 mm motion-picture film

Dimension	Type 1 (laboratory) <sup>1)</sup>		Type 2 (projection) (non-anamorphic)		Type 3 (projection) (anamorphic) <sup>2)</sup>	
	mm	in	mm	in	mm	in
A nom.	1,24	0,049	1,83	0,072	1,24	0,049
B	14,22 ± 0,05	0,560 ± 0,002	14,25 ± 0,05	0,561 ± 0,002	14,25 ± 0,05	0,561 ± 0,002
C	7,42 ± 0,05	0,292 ± 0,002	7,21 ± 0,10	0,284 ± 0,004	7,42 ± 0,05	0,292 ± 0,002
D	8,66 ± 0,05	0,341 ± 0,002	9,04 ± 0,10	0,356 ± 0,004	8,66 ± 0,05	0,341 ± 0,002

1) Dimension A should not be greater than 1,02 mm (0,040 in) in the anamorphic negative in order to minimize intrusion of the splice in the projected image area.

2) It should be noted that Type 3 splices on anamorphic film will fall within the projected area and extra care should be taken in making a clean splice.

**Table 3 — Dimensions of splices for 70 mm and 65 mm motion-picture films**

Dimension	Type 1 (laboratory) 65 mm		Type 2 (projection) 70 mm	
	mm	in	mm	in
A nom.	1,70	0,067	1,70	0,067
B	14,22 ± 0,05	0,560 ± 0,002	14,25 ± 0,05	0,561 ± 0,002
C	7,27 ± 0,05	0,286 ± 0,002	7,27 ± 0,05	0,286 ± 0,002
D	8,97 ± 0,05	0,353 ± 0,002	8,97 ± 0,05	0,353 ± 0,002

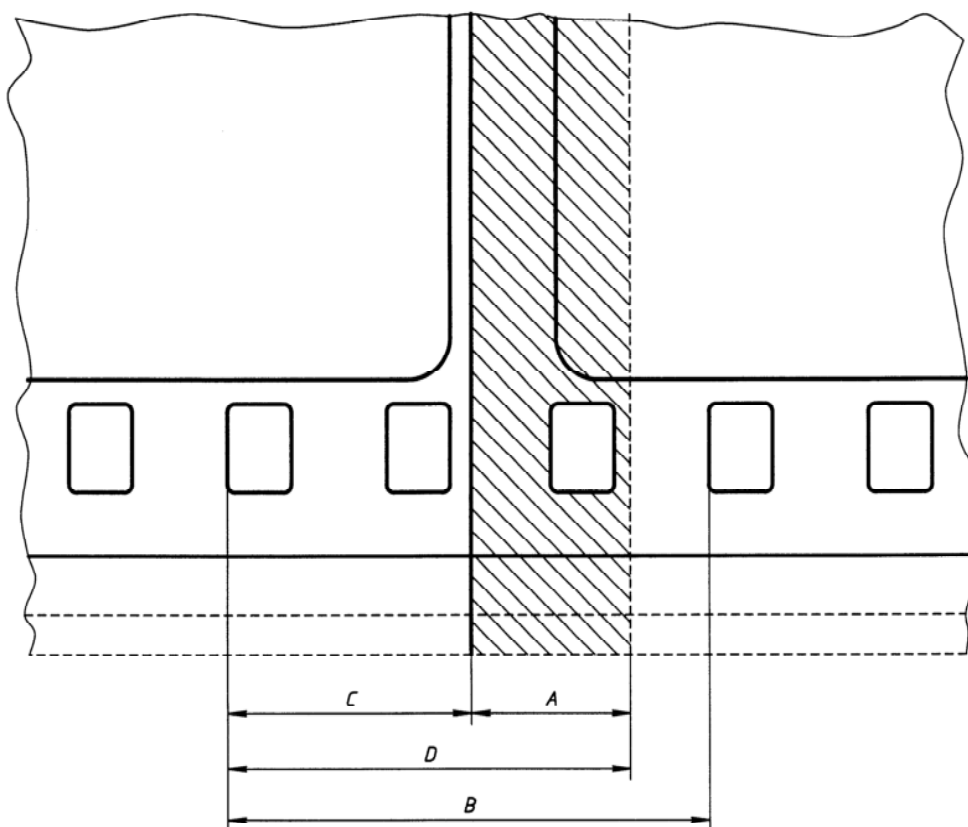

**Figure 4 — Full perforation splices on 35 mm projection prints**

**Table 4 — Dimensions of splices on 35 mm cemented and welded motion-picture projection prints**

Dimension	mm	in
A nom.	3,96	0,156
B	$14,25 \pm 0,05$	$0,561 \pm 0,002$
C	$8,13 \pm 0,05$	$0,320 \pm 0,002$
D	$12,09 \pm 0,05$	$0,476 \pm 0,002$

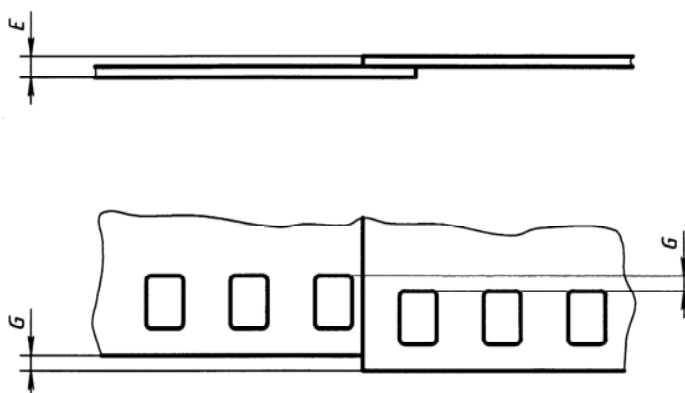

**Figure 5 — For all film widths**

**Table 5 — Dimensions for all splices**

Dimension	mm	in
E max.	0,33	0,013
G max. <sup>1)</sup>	0,05	0,002

1) A difference in the lateral shrinkages of the two strips can make it impossible to maintain the tolerance. Shoulders formed by such misalignment should be bevelled.

**2.6** The angle between the respective edges of the spliced films shall be  $180^\circ \pm 4'$ . Thus, the spliced film shall be aligned to the extent that when one portion of the film is placed against a straight edge, the other portion does not deviate by more than 0,15 mm (0,006 in) per 13 cm (5 in).

### 3 General requirements

**3.1** Butt and overlap tape splices shall be made with an optically clear, transparent tape.

**3.2** All splices shall be capable of withstanding a tension which is at least 50 % greater than the gate tension of the projector for that film width.

**3.3** After splicing, the perforation holes shall be maintained clear at all splices.

**3.4** If the film to be spliced contains a photographic sound track and the modulation level at the point of the splice results in any individual bias line having a width of less than 0,05 mm, then the sound track should be blooped or opaqued to avoid an objectionable audio crash.

### 4 Overlap splices

#### 4.1 General

**4.1.1** The overlap provides the desirable increase in stiffness at the splice to prevent sharp angular bending when the film goes around a small radius, as in the free loops above and below the projection aperture.

**4.1.2** When the overlap splice receives its mechanical strength from tape, it is usual not to scrape or otherwise remove the emulsion in the overlap area.

## 4.2 Recommendations for cemented overlap splices

**4.2.1** The scraped area of one film end should be 0,03 mm to 0,08 mm (0,001 in to 0,003 in) narrower than the area covered by the overlapping film in order to prevent the appearance of a white line on the screen.

**4.2.2** When splicing, the following recommendations should be observed:

- a) the cement should be applied to the full width of the splice;
- b) no air bubbles should be in the splice;
- c) cement excess should be removed, including that from the perforation holes.

**4.2.3** If the film being spliced contains a magnetic stripe, the stripe should be removed from the base of the film falling on top of the mating piece.

**4.2.4** Bevelled splices are recommended and scraping at an angle is preferred because it provides a stronger splice. When film with magnetic stripes is spliced, it is recommended that the overlap should be oriented so that the trailing film drops on to the scanning head rather than jolts up on to it.

**4.2.5** An overlap cement splice may be reinforced with splicing tape.

## 5 Butt tape splices

**5.1** Butt splices shall be made centrally on the frame line.

**5.2** The clearance between the butted edges of the print at the splices shall not exceed 0,08 mm (0,003 in).

**5.3** The dimensions of the tape applied to secure a butt splice shall not interfere with the film dimensions as specified in the International Standard for the particular film type.

**5.4** The tape shall be wide enough to cover an area of at least half a frame on each side of the splice. It is preferred that the tape begins and ends on a frame line so that the splice will be less visible.

**5.5** The tape shall adhere uniformly to the film without corrugations or entrapped air bubbles.

**5.6** For films with photographic sound records, the width of the tape used shall cover the full width of the film on both sides. For films with magnetic sound records, tape used on that side which does not carry the magnetic record and balancing stripes shall cover the full width of the film. Tape used on the side carrying the magnetic record shall not be placed in an area contacted by the magnetic heads.

**5.7** Butt splices shall not be made with tape on one side only since such films are not functional in projection.

**5.8** Butt splices shall not be made with tape wrapped around the film since this interferes with guiding.



## Annex A (informative)

### Bibliography

- [1] ISO 69:1990, *Cinematography — 16 mm motion-picture and magnetic film — Cutting and perforating dimensions.*
- [2] ISO 466:1976, *Cinematography — Image produced by 16 mm motion-picture camera aperture — Position and dimensions.*
- [3] ISO 491:1988, *Cinematography — 35 mm motion-picture film and magnetic film — Cutting and perforating dimensions.*
- [4] ISO 2467:1980, *Cinematography — Image area produced by 65 and 70 mm motion-picture camera aperture and maximum projectable image area on 70 mm motion-picture prints — Positions and dimensions.*
- [5] ISO 2906:1984, *Cinematography — Image area produced by camera aperture on 35 mm motion-picture film — Position and dimensions.*
- [6] ISO 3023:1988, *Cinematography — 65 mm and 70 mm unexposed motion-picture film — Cutting and perforating dimensions.*

---

---

**UDC 778.531.351/.353:778.582**

**Descriptors:** cinematography, motion-picture film, motion-picture film 70 mm, motion-picture film 65 mm, motion-picture film 35 mm, motion-picture film 16 mm, film splices, classification, dimensions, position (location).

Price based on 7 pages

---

---