

INTERNATIONAL
STANDARD

ISO
6020-3

First edition
1994-09-01

**Hydraulic fluid power — Mounting
dimensions for single rod cylinders, 16 MPa
(160 bar) series —**

Part 3:

Compact series with bores from 250 mm to
500 mm

*Transmissions hydrauliques — Dimensions d'interchangeabilité des vérins
16 MPa (160 bar) à simple tige —*

Partie 3: Série compacte, alésages de 250 mm à 500 mm



Reference number
ISO 6020-3:1994(E)

Foreword

ISO (the International Organization for Standardization) is a worldwide federation of national standards bodies (ISO member bodies). The work of preparing International Standards is normally carried out through ISO technical committees. Each member body interested in a subject for which a technical committee has been established has the right to be represented on that committee. International organizations, governmental and non-governmental, in liaison with ISO, also take part in the work. ISO collaborates closely with the International Electrotechnical Commission (IEC) on all matters of electrotechnical standardization.

Draft International Standards adopted by the technical committees are circulated to the member bodies for voting. Publication as an International Standard requires approval by at least 75 % of the member bodies casting a vote.

International Standard ISO 6020-3 was prepared by Technical Committee ISO/TC 131, *Fluid power systems*, Subcommittee SC 3, *Cylinders*.

ISO 6020 consists of the following parts, under the general title *Hydraulic fluid power — Mounting dimensions for single rod cylinders, 16 MPa (160 bar) series*:

- *Part 1: Medium series*
- *Part 2: Compact series*
- *Part 3: Compact series with bores from 250 mm to 500 mm*

Annex A of this part of ISO 6020 is for information only.

© ISO 1994

All rights reserved. Unless otherwise specified, no part of this publication may be reproduced or utilized in any form or by any means, electronic or mechanical, including photocopying and microfilm, without permission in writing from the publisher.

International Organization for Standardization
Case Postale 56 • CH-1211 Genève 20 • Switzerland

Printed in Switzerland

Introduction

In hydraulic fluid power systems, power is transmitted and controlled through a liquid under pressure within an enclosed circuit.

One component of such systems is the fluid power cylinder. This is a device which converts power into linear mechanical force and motion. It consists of a movable element, i.e. a piston and piston rod, operating within a cylindrical bore.

Hydraulic fluid power — Mounting dimensions for single rod cylinders, 16 MPa (160 bar) series —

Part 3:

Compact series with bores from 250 mm to 500 mm

1 Scope

This part of ISO 6020 establishes metric mounting dimensions for compact-series cylinders with bores from 250 mm to 500 mm, 16 MPa [160 bar¹⁾], as required for interchangeability of commonly used hydraulic cylinders.

NOTES

1 This part of ISO 6020 allows manufacturers of hydraulic equipment flexibility in the design of metric cylinders and does not restrict technical development but does provide basic guidelines.

2 The compact-series dimensions are most applicable to square-head cylinders.

This part of ISO 6020 only applies to the dimensions of manufactured products. It does not apply to their functional characteristics.

2 Normative references

The following standards contain provisions which, through reference in this text, constitute provisions of this part of ISO 6020. At the time of publication, the editions indicated were valid. All standards are subject to revision, and parties to agreements based on this part of ISO 6020 are encouraged to investigate the possibility of applying the most recent editions of the standards indicated below. Members of IEC and ISO maintain registers of currently valid International Standards.

1) 1 bar = 0,1 MPa = 10⁵ Pa; 1 MPa = 1 N/mm²

ISO 273:1979, *Fasteners — Clearance holes for bolts and screws.*

ISO 3320:1987, *Fluid power systems and components — Cylinder bores and piston rod diameters — Metric series.*

ISO 4395:1978, *Fluid power systems and components — Cylinders — Piston rod thread dimensions and types.*

ISO 5598:1985, *Fluid power systems and components — Vocabulary.*

ISO 6162:1994, *Hydraulic fluid power — Four-screw split-flange connections for use at pressures of 2,5 MPa to 40 MPa (25 bar to 400 bar) — Type I metric series and type II inch series.*

3 Definitions

For the purposes of this part of ISO 6020, the definitions given in ISO 5598 and the following definitions apply.

3.1 cylinder: Device which converts fluid power into linear mechanical force and motion.

3.2 cylinder bore: Internal diameter of the cylinder body.

3.3 piston rod: Element which transmits mechanical force and motion from the piston.

3.4 mounting: Device by which a cylinder is fastened to its mating element.

4 Dimensions

Mounting dimensions for cylinders manufactured in accordance with this part of ISO 6020 shall be selected from tables 1 to 9.

5 Bore sizes

The following bore sizes, in millimetres, are included in this compact series:

250 — 320 — 360²⁾ — 400 — 500

6 Mounting styles

This part of ISO 6020 includes the following mounting styles, in accordance with ISO 6099.

MF5 — Head, square flange (see figure 2 and table 2)

MF6 — Cap, square flange (see figure 3 and table 3)

MP1 — Cap, fixed clevis (see figure 4 and table 4)

MP3 — Cap, fixed eye (see figure 5 and table 5)

MP5 — Cap, fixed eye with spherical plain bearing (see figure 6 and table 6)

MT1 — Head, integral trunnion (male) (see figure 7 and table 7)

MT2 — Cap, integral trunnion (male) (see figure 8 and table 8)

MT4 — Intermediate fixed or movable trunnion (male) (see figure 9 and table 9).

7 Piston rod characteristics

7.1 This part of ISO 6020 covers piston rods which have a shouldered male thread end (see figure 1 and table 1 for basic dimensions).

7.2 For internally threaded rod ends, see ISO 4395.

7.3 For rod end eyes, International Standards are being prepared.

8 Identification statement (Reference to this part of ISO 6020)

Use the following statement in test reports, catalogues and sales literature when electing to comply with this part of ISO 6020:

"Interchangeable cylinder mounting dimensions selected in accordance with ISO 6020-3:1994, *Hydraulic fluid power — Mounting dimensions for single rod cylinders, 16 MPa (160 bar) series — Part 3: Compact series with bores from 250 mm to 500 mm.*"

2) Non-preferred size.

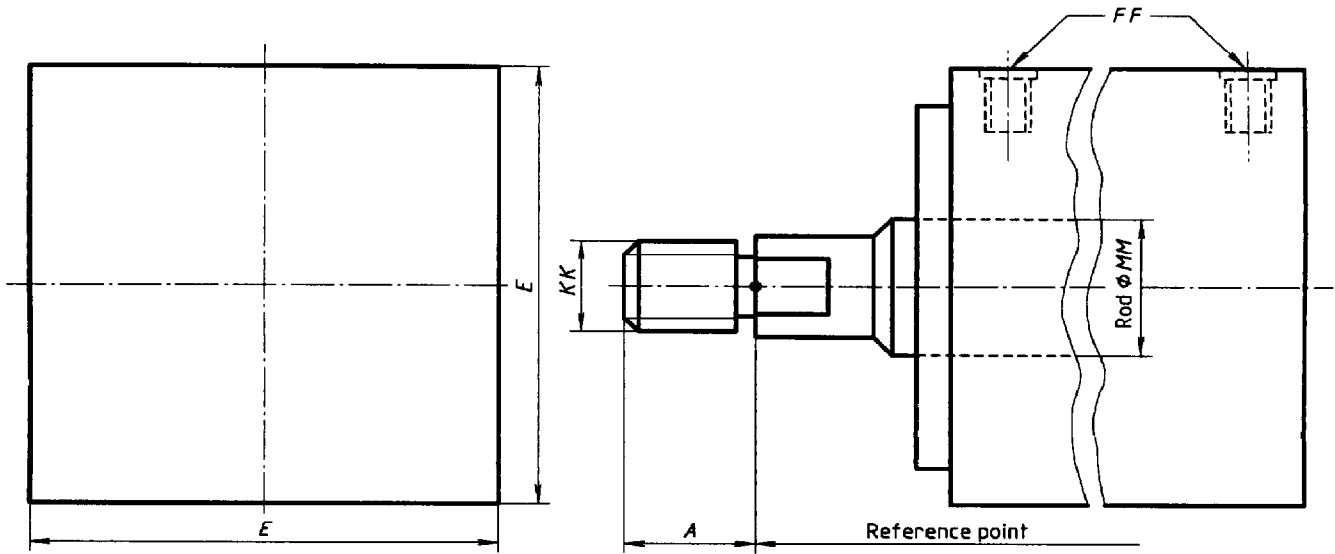

Figure 1 — General dimensions

Table 1 — General dimensions and part sizes

Dimensions in millimetres

Bore	Rod ¹⁾ MM	KK	A	E max.	FF ²⁾
250	140	M100 × 3	112	320	DN 51
	180	M125 × 4	125		
320	180	M125 × 4	125	400	DN 64
	220	M160 × 4	160		
360 ³⁾	180	M125 × 4	125	450	DN 64
	250	M180 × 4	180		
400	220	M160 × 4	160	500	DN 64
	280	M200 × 4	200		
500	280	M200 × 4	200	630	DN 64
	360	M250 × 6	250		

1) Other piston rods that appear in ISO 3320 may be used.

2) See ISO 6162 for flange port dimensions.

3) 360 mm bore is a non-preferred size.

Dimensions in millimetres

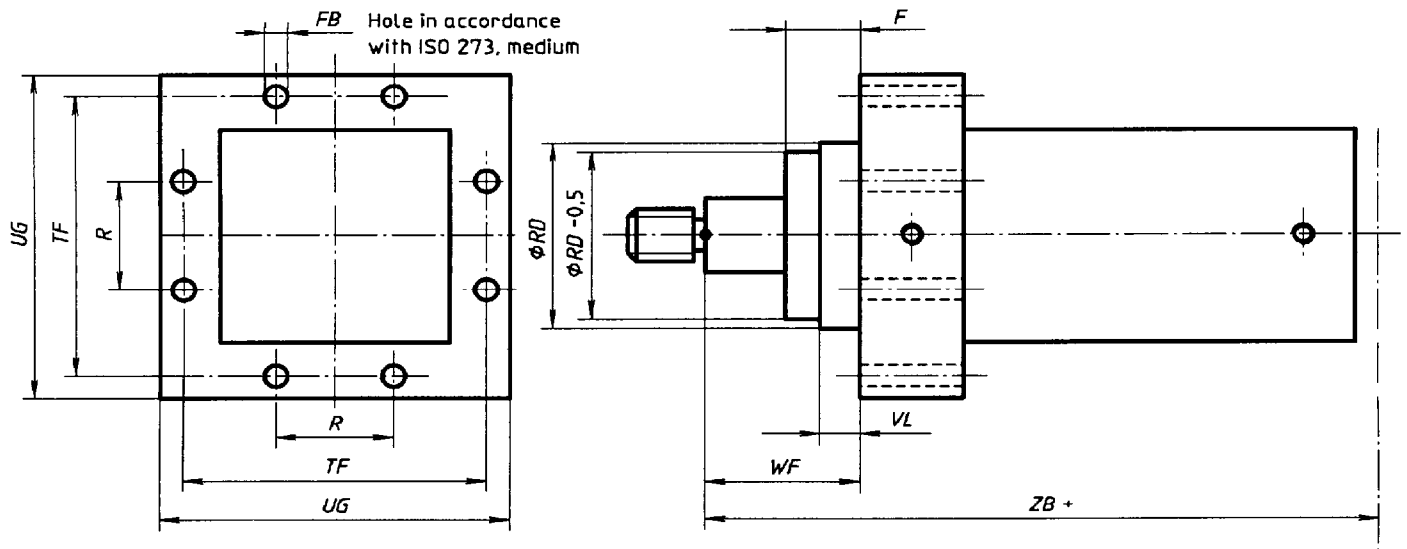

Figure 2 — MF5 — Head mounting, square flange

Table 2 — Dimensions of head mountings, square flange

Dimensions in millimetres

Bore	Rod ¹⁾ MM	RD f8	TF	FB	R	WF	F max.	VL min.	UG max.	ZB max.
250	140	280	380	30	235	110	75	5	445	460
	180									
320	180	325	472	36	283	110	75	5	549	520
	220									
360 ²⁾	180	350	528	39	305	110	75	5	611	575
	250									
400	220	380	588	45	340	110	75	5	683	625
	280									
500	280	490	740	56	425	110	75	5	858	775
	360									

1) Other piston rods that appear in ISO 3320 may be used.

2) 360 mm bore is a non-preferred size.

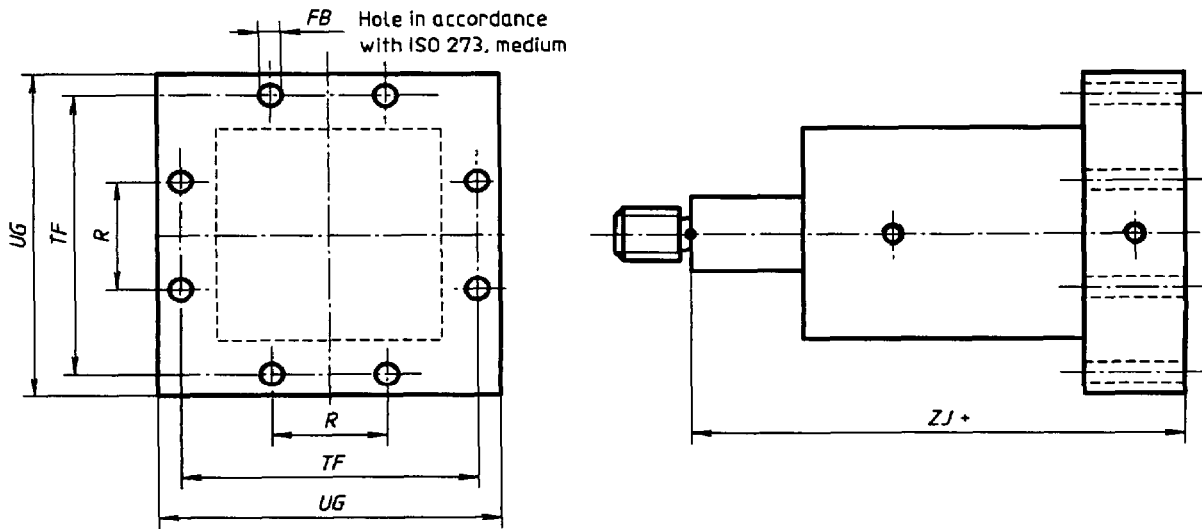

Figure 3 — MF6 — Cap mounting, square flange

Table 3 — Dimensions of cap mountings, square flange

Dimensions in millimetres

Bore	Rod ¹⁾ MM	TF	FB	R	ZJ	UG max.
250	140	380	30	235	420	445
	180					
320	180	472	36	283	475	549
	220					
360 ²⁾	180	528	39	305	530	611
	250					
400	220	588	45	340	580	683
	280					
500	280	740	56	425	710	858
	360					

1) Other piston rods that appear in ISO 3320 may be used.

2) 360 mm bore is a non-preferred size.

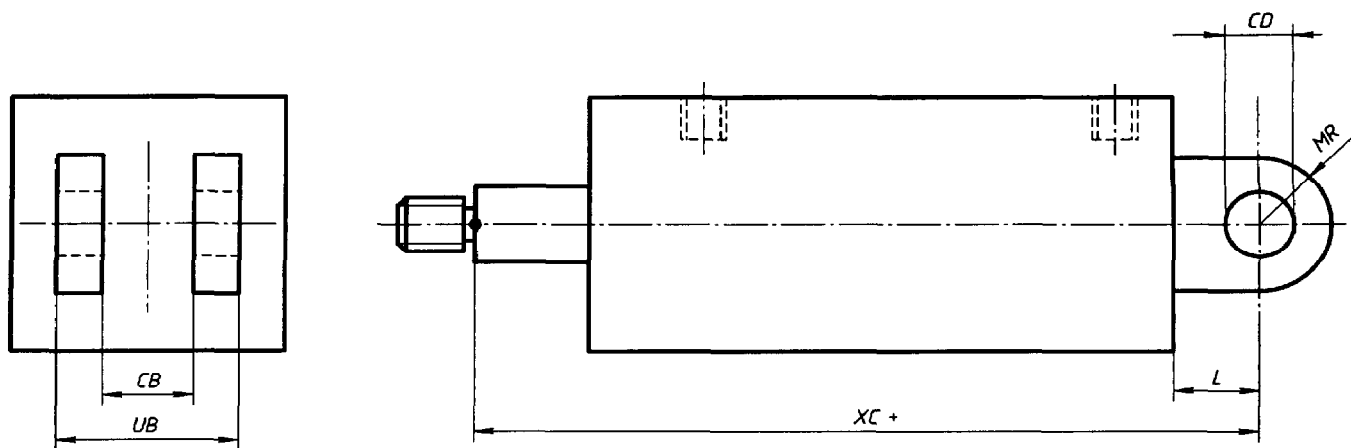

Figure 4 — MP1 — Cap mounting, fixed clevis

Table 4 — Dimensions of cap mountings, fixed clevis

Dimensions in millimetres

Bore	Rod ¹⁾ MM	CB	CD	MR max.	L min.	XC	UB
250	140	90	90	100	125	545	180
	180						
320	180	110	110	120	152	627	220
	220						
360 ²⁾	180	125	125	140	175	705	250
	250						
400	220	140	140	160	195	775	280
	280						
500	280	180	180	200	250	960	360
	360						

1) Other piston rods that appear in ISO 3320 may be used.

2) 360 mm bore is a non-preferred size.

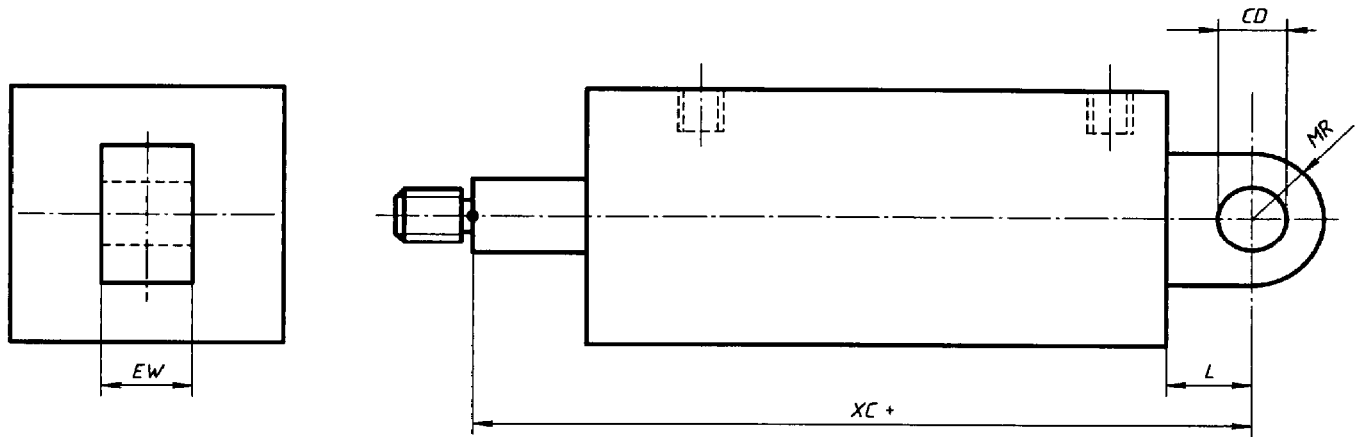

Figure 5 — MP3 — Cap mounting, fixed eye

Table 5 — Dimensions of cap mountings, fixed eye

Dimensions in millimetres

Bore	Rod ¹⁾ MM	EW	CD	MR max.	L min.	XC
250	140	90	90	100	125	545
	180					
320	180	110	110	120	152	627
	220					
360 ²⁾	180	125	125	140	175	705
	250					
400	220	140	140	160	195	775
	280					
500	280	180	180	200	250	960
	360					

1) Other piston rods that appear in ISO 3320 may be used.

2) 360 mm bore is a non-preferred size.

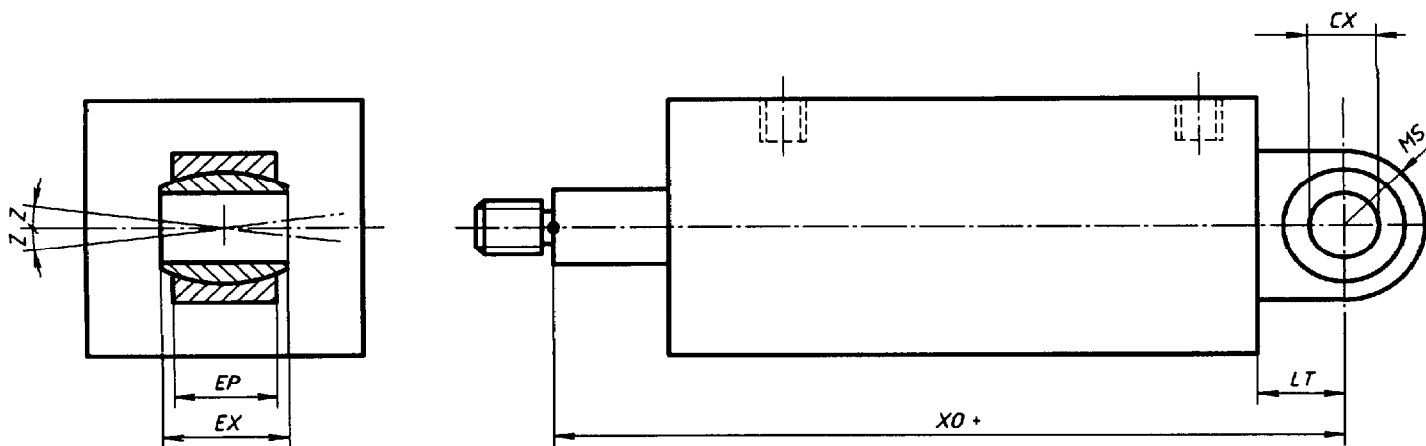

Figure 6 — MP5 — Cap mounting, fixed eye with spherical plain bearing

Table 6 — Dimensions of cap mountings, fixed eye with spherical plain bearing

Dimensions in millimetres

Bore	Rod ¹⁾ MM	EP	EX	CX	MS max.	LT	XO	Tilting angle Z min.
250	140	102	125	125	160	160	580	4°
	180							
320	180	130	160	160	200	200	675	
	220							
360 ²⁾	180	130	160	160	200	200	730	
	250							
400	220	162	200	200	250	250	830	
	280							
500	280	192	250	250	320	320	1 030	
	360							

1) Other piston rods that appear in ISO 3320 may be used.

2) 360 mm bore is a non-preferred size.

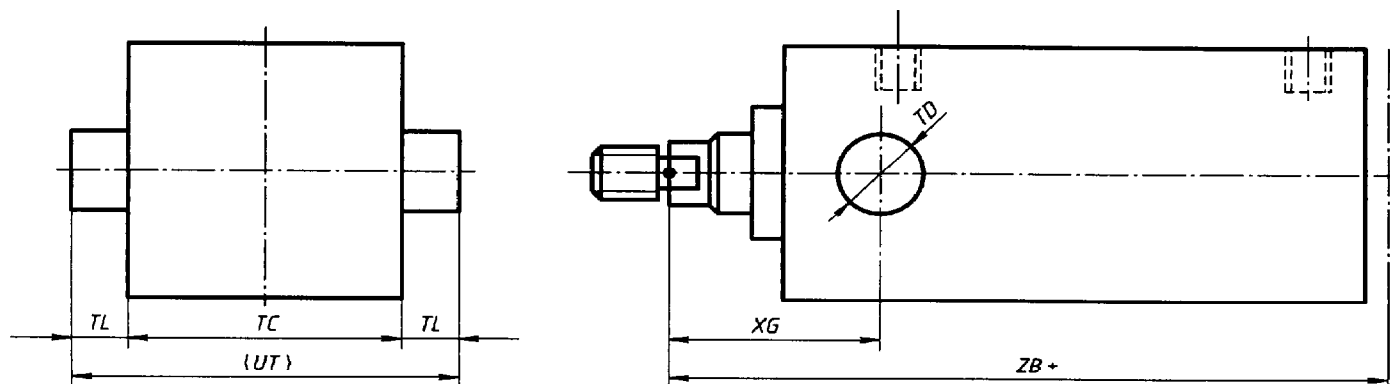

Figure 7 — MT1 — Head mounting, integral trunnion (male)

Table 7 — Dimensions of head mountings, integral trunnion (male)

Dimensions in millimetres

Bore	Rod ¹⁾ MM	TC	UT	TD	XG	TL	ZB max.
250	140	320	520	125	178	100	505
	180						
320	180	400	650	160	195	125	580
	220						
360 ²⁾	180	450	740	180	205	145	640
	250						
400	220	500	820	200	215	160	685
	280						
500	280	630	1 030	250	240	200	825
	360						

1) Other piston rods that appear in ISO 3320 may be used.

2) 360 mm bore is a non-preferred size.

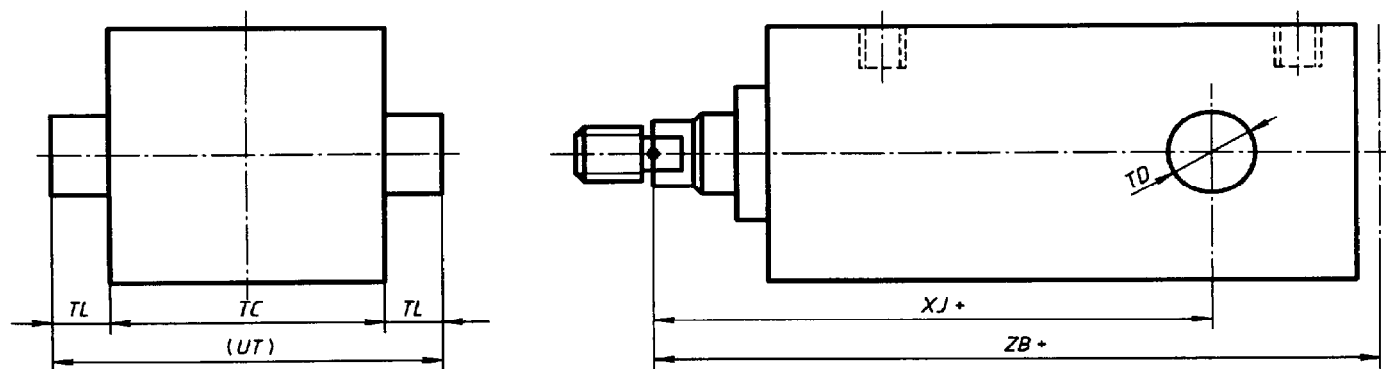

Figure 8 — MT2 — Cap mounting, integral trunnion (male)

Table 8 — Dimensions of cap mountings, integral trunnion (male)

Dimensions in millimetres

Bore	Rod ¹⁾ MM	TC	UT	TD	XJ	TL	ZB max.
250	140	320	520	125	393	100	505
	180						
320	180	400	650	160	450	125	580
	220						
360 ²⁾	180	450	740	180	500	145	640
	250						
400	220	500	820	200	525	160	685
	280						
500	280	630	1 030	250	615	200	825
	360						

1) Other piston rods that appear in ISO 3320 may be used.

2) 360 mm bore is a non-preferred size.

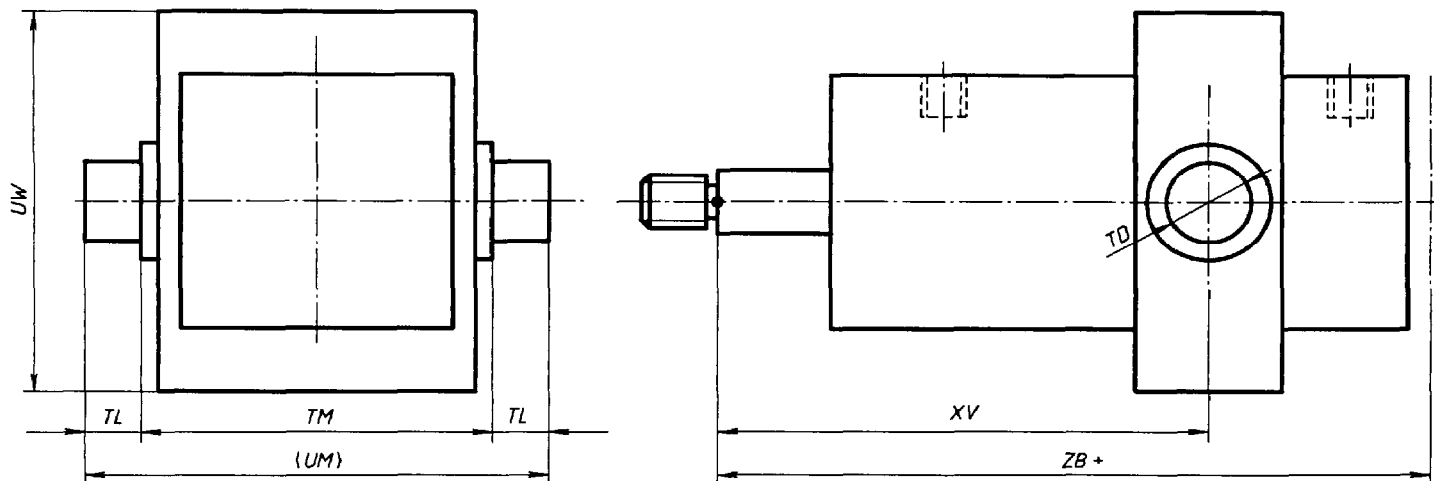

Figure 9 — MT4 — Mounting with intermediate fixed or movable trunnions (male)

Table 9 — Dimensions of mountings with intermediate fixed or movable trunnions (male)

Dimensions in millimetres

Bore	Rod ¹⁾ MM	UW max.	TM	UM	TD	XV	ZB max.	TL
250	140	480	380	580	125	variable ³⁾	460	100
	180							
320	180	600	485	735	160		520	125
	220							
360 ²⁾	180	675	545	835	180		575	145
	250							
400	220	750	605	925	200	625	160	
	280							
500	280	945	745	1 145	250	775	200	
	360							

1) Other piston rods that appear in ISO 3320 may be used.

2) 360 mm bore is a non-preferred size.

3) XV min., XV max. and minimum stroke shall be as agreed between the manufacturer and user.

Annex A

(informative)

Bibliography

- [1] ISO 4393:1978, *Fluid power systems and components — Cylinders — Basic series of piston strokes.*
- [2] ISO 4394-1:1980, *Fluid power systems and components — Cylinder barrels — Part 1: Requirements for steel tubes with specially finished bores.*
- [3] ISO 6099:1985, *Fluid power systems and components — Cylinders — Identification code for mounting dimensions and mounting types.*

ICS 23.100.20

Descriptors: hydraulic fluid power, hydraulic equipment, hydraulic cylinders, single rod cylinders, fastening flanges, dimensions, mounting dimensions, interchangeability.

Price based on 12 pages
