International Standard 6003

INTERNATIONAL ORGANIZATION FOR STANDARDIZATION • МЕЖДУНАРОДНАЯ ОРГАНИЗАЦИЯ ПО СТАНДАРТИЗАЦИИ • ORGANISATION INTERNATIONALE DE NORMALISATION

Alpine skis — Determination of mass and polar moment of inertia — Laboratory measurement method

Skis alpins — Détermination de la masse et du moment d'inertie polaire — Méthode de mesurage en laboratoire

Second edition — 1984-07-15

UDC 685.363.2 : 531.751.3 : 531.231

Ref. No. ISO 6003-1984 (E)

Descriptors : sports equipment, skis, alpine skis, tests, laboratory tests, determination, moment of inertia, mass, test equipment.

Foreword

ISO (the International Organization for Standardization) is a worldwide federation of national standards bodies (ISO member bodies). The work of developing International Standards is carried out through ISO technical committees. Every member body interested in a subject for which a technical committee has been authorized has the right to be represented on that committee. International organizations, governmental and non-governmental, in liaison with ISO, also take part in the work.

Draft International Standards adopted by the technical committees are circulated to the member bodies for approval before their acceptance as International Standards by the ISO Council.

International Standard ISO 6003 was developed by Technical Committee ISO/TC 83, *Sports and recreational equipment*, and was circulated to the member bodies in August 1983.

It has been approved by the member bodies of the following countries:

Austria	Germany, F.R.	South Africa, Rep. of
Czechoslovakia	India	USA
Egypt, Arab Rep. of	Italy	USSR
Finland	Japan	
France	Poland	

No member body expressed disapproval of the document.

This second edition cancels and replaces the first edition (i.e. ISO 6003-1980).

Alpine skis — Determination of mass and polar moment of inertia — Laboratory measurement method

1 Scope and field of application

This International Standard specifies laboratory measurement methods for mass and polar moment of inertia of alpine skis.

If laboratory measurement data are determined and published by the ski manufacturer or other institutions, standard measurement procedures are recommended to ensure comparability.

This International Standard also specifies a tolerance range which shall be met by the measurement data of all manufactured skis, if for the specific model length measurement data are published by the manufacturer of the ski.

NOTE — The appropriate ski length should be given with the published measurement data.

It is not the purpose of this International Standard to evaluate the measurement data with regard to their influence on the quality of the ski.

2 Reference

ISO 554, *Standard atmospheres for conditioning and/or testing — Specifications.*

3 Definitions

3.1 mass of ski, m : The mass of a finished manufactured ski without any mounted parts, expressed in kilograms.

3.2 polar moment of inertia, I : The mass moment of inertia, expressed in kilogram metres squared, of the ski about its centre of gravity.

4 Apparatus

4.1 Weighing device, accurate to $\pm 0,02$ kg.

4.2 Fulcrum, for locating the centre of gravity of the ski.

4.3 Time measurement device (stop watch), accurate to at least 0,1 s.

4.4 Measuring device in accordance with the figure, consisting of the following parts:

4.4.1 Clamping device A (see the figure), consisting of two clamping fixtures. The top clamping fixture has a hole with a mark to locate the centre of gravity and a further two holes at a distance e from the centre mark for fixation of the filaments B.

The recommended dimension for e is 25 mm and the mass of the clamping device shall be less than 0,1 kg.

4.4.2 Top plate C, with two holes separated by the distance $2d_f$ for the fixation of filaments B. The plate C shall be fixed on a stiff, horizontal beam.

4.4.3 Two filaments B, with equal length l , which connect the top plate with the clamping device. The ratio $d_f : l$ shall be approximately 1 : 40. With the recommended dimension $d_f = 25$ mm; the length l shall be 1 000 mm. The filaments shall be made of materials with low elongation and high strength (for example tennis string, silk fishing line).

The diameter of the filaments shall be not more than 1,0 mm.

5 Sampling and conditioning

5.1 In order to ensure comparability it is recommended to use one of the following ski sizes if data of measurements are published:

150, 180 or 200 cm.

From these three sizes the one which is most representative for the tested model shall be selected.

5.2 All measurements according to this International Standard shall be taken from a finished manufactured ski without any mounted parts.

5.3 All measurements according to this International Standard shall be taken with a measuring device, which has been conditioned in a standard atmosphere 20/65 ISO 554 (i.e. the device shall be placed in this atmosphere for at least 24 h before measurement).

6 Calibration of measuring device

Differences in construction between the different measuring devices can lead to different measurement results, which deviate from the theoretical accurate value of the polar moment of inertia.

In order to compensate such deviations it is recommended to determine a correction factor c for each measuring device, to correct the measured data and improve reproducibility.

The correction factor is determined from the ratio of the calculated polar moment of inertia to the measured polar moment of inertia of a bar of steel with dimensions 0,1 cm × 2 cm × 170 cm.

The theoretical polar moment of inertia, I_{th} , is calculated by the formula

$$I_{th} = \frac{m(a^2 + b^2)}{12}$$

where

a is the length of the bar in metres;

b is the width of the bar in metres;

m is the mass of the bar in kilograms.

Using this theoretical value and the measured value the correction factor, c , can be determined by

$$c = \frac{I_{th}}{I}$$

where

I_{th} is the theoretical polar moment of inertia;

I is the measured polar moment of inertia.

This factor should fall within a range of 0,9 and 1,1.

If this factor lies outside of this range, the test equipment shall be checked and brought into closer conformity with this International Standard.

7 Procedure

Measure the mass of the ski with the weighing device (4.1).

Place the ski on the fulcrum (4.2), to determine the centre of gravity, until it balances. The centre shall be marked with a cross sign.

Mount the ski in the clamping device A (4.4.1) in such a way that the centre of gravity mark is in the centre of the hole of the top clamping fixture midway between the two filaments. The longitudinal centre axis shall be perpendicular to a line drawn between the two filaments B (see the figure).

Let the ski come to rest suspended in the device. Eliminate any swinging motion. It is important that the test area be free of air movement, as this affects test accuracy.

With the hand, rotate the ski horizontally about its axis of gravity. Lateral displacement of the centre of gravity exceeding 10 mm shall be avoided. The twist angle should be approximately 25°.

After displacement the ski is released to swing freely around the perpendicular axis through the centre of gravity. The time required for the ski to complete five cycles is recorded with the stop watch (4.3). The time, T , for 1 oscillation is determined by

$$T = \frac{\text{recorded time}}{5}$$

8 Expression of results

8.1 Mass of the ski

Report the mass, m , of the ski in kilograms.

8.2 Polar moment of inertia of the ski

The polar moment of inertia, I , expressed in kilogram metres squared, is given by the formula

$$I = \left(\frac{T}{2\pi}\right)^2 mg \frac{d_f^2}{l}$$

where

T is the period of oscillation, in seconds;

m is the mass of the finished manufactured ski without any ancillary parts, in kilograms;

g is the acceleration due to gravity, in metres per second squared;

d_f is the half distance between the filaments measured on the top plate, in metres;

l is the length of the filaments, in metres.

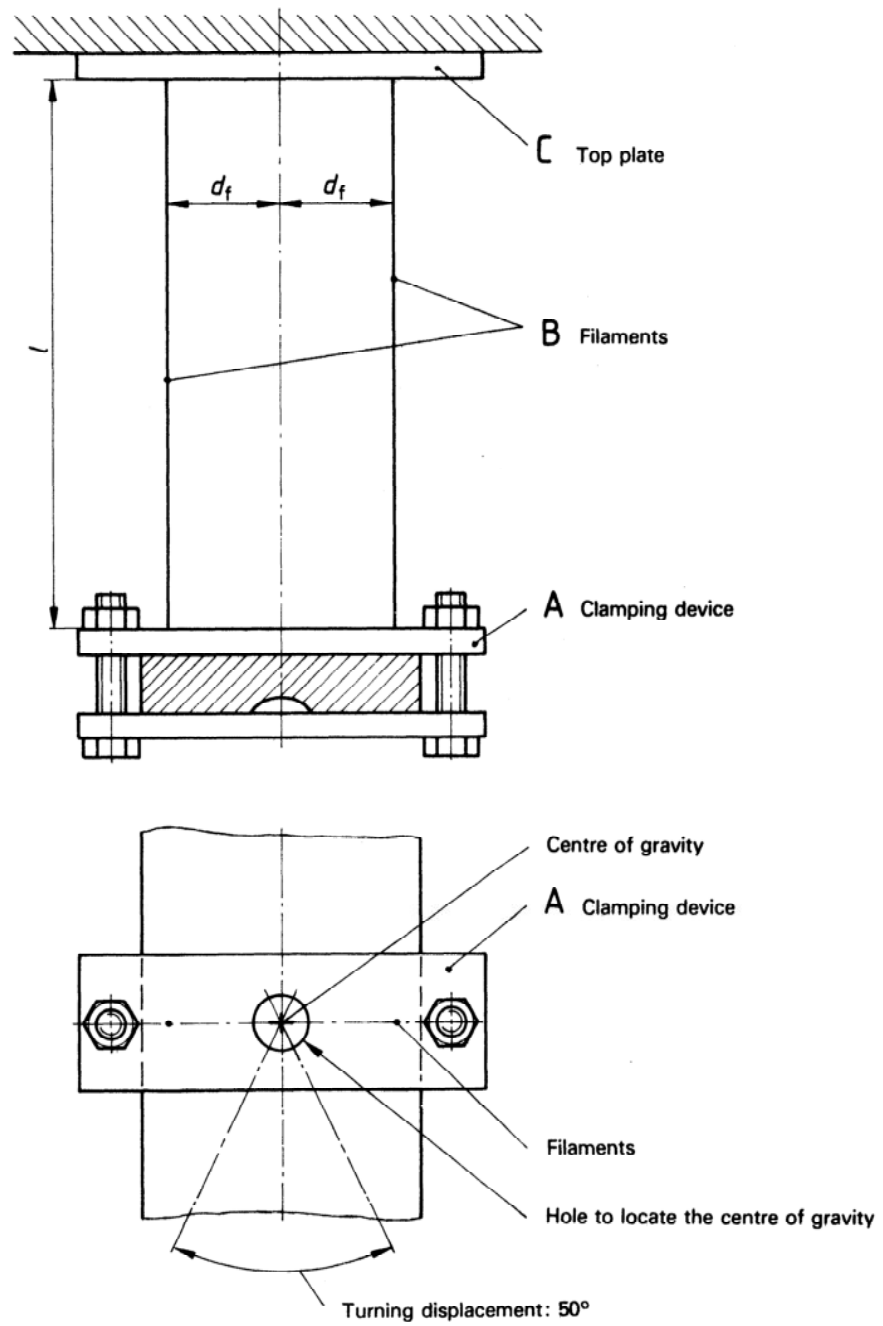

Figure – Measurement device for the determination of the polar moment of inertia

9 Tolerances

9.1 Measurement tolerances

mass:	$\pm 0,02$ kg
polar moment of inertia:	$\pm 0,02$ kgm ²

9.2 Tolerances on published data

If data are published by the manufacturer with reference to this International Standard, the following tolerances shall be observed:

mass:	± 10 %
polar moment of inertia:	± 10 %

10 Test report

The test report shall include the following information:

- a) reference to this International Standard;
- b) name of the manufacturer;
- c) model designation;
- d) nominal length;
- e) registration number of the ski;
- f) any deviation from this International Standard with an explanation of the reason for the deviation.

This page intentionally left blank

This page intentionally left blank