

INTERNATIONAL STANDARD

ISO
6002

First edition
1992-06-15

Bolted bonnet steel gate valves

Robinets-vannes en acier à chapeau boulonné



Reference number
ISO 6002:1992(E)

Contents

	Page
1 Scope	1
2 Normative references	1
3 Definitions	1
4 Pressure/temperature ratings	2
5 Design	2
6 Materials	10
7 Testing and inspection	11
8 Marking	11

© ISO 1992

All rights reserved. No part of this publication may be reproduced or utilized in any form or by any means, electronic or mechanical, including photocopying and microfilm, without permission in writing from the publisher.

International Organization for Standardization
Case Postale 56 • CH-1211 Genève 20 • Switzerland

Printed in Switzerland

Foreword

ISO (the International Organization for Standardization) is a worldwide federation of national standards bodies (ISO member bodies). The work of preparing International Standards is normally carried out through ISO technical committees. Each member body interested in a subject for which a technical committee has been established has the right to be represented on that committee. International organizations, governmental and non-governmental, in liaison with ISO, also take part in the work. ISO collaborates closely with the International Electrotechnical Commission (IEC) on all matters of electrotechnical standardization.

Draft International Standards adopted by the technical committees are circulated to the member bodies for voting. Publication as an International Standard requires approval by at least 75 % of the member bodies casting a vote.

International Standard ISO 6002 was prepared by Technical Committee ISO/TC 153, *Valves*, Sub-Committee SC 1, *Design, manufacture, marking and testing*.

Introduction

The purpose of this International Standard is the establishment of the basic requirements and recommendations for flanged or butt-weld end steel gate valves of bolted bonnet construction.

To maintain compatibility with ISO 7005-1 whereby the American flanges previously designated by a class rating have been converted to nominal pressure (PN) ratings, this International Standard follows the same system. The equivalent ratings are as follows:

Class 150: PN 20

Class 300: PN 50

Class 600: PN 100

Bolted bonnet steel gate valves

1 Scope

This International Standard specifies the requirements for bolted bonnet steel gate valves having the following features:

- bolted bonnet;
- outside screw and yoke;
- inside screw (alternative for PN 10, PN 16, PN 20, PN 25 and PN 40 only);
- single or double obturator;
- wedge or parallel seating;
- with or without non-metallic obturator or seat seals;
- flanged or butt-welding ends.

It covers valves of the nominal sizes DN

10; 15; 20; 25; 32; 40; 50; 65; 80; 100; 125; 150; 200; 250; 300; 350; 400; 450; 500; 600; 700; 800; 900; 1 000,

and applies to valves of the nominal pressures PN

10; 16; 20; 25; 40; 50; 100.

2 Normative references

The following standards contain provisions which, through reference in this text, constitute provisions of this International Standard. At the time of publication, the editions indicated were valid. All stan-

dards are subject to revision, and parties to agreements based on this International Standard are encouraged to investigate the possibility of applying the most recent editions of the standards indicated below. Members of IEC and ISO maintain registers of currently valid International Standards.

ISO 7-1:1982, *Pipe threads where pressure-tight joints are made on the threads — Part 1: Designation, dimensions and tolerances.*

ISO 5208:—¹⁾, *Industrial valves — Pressure testing of valves.*

ISO 5210:1991, *Industrial valves — Multi-turn valve actuator attachments.*

ISO 5752:1982, *Metal valves for use in flanged pipe systems — Face-to-face and centre-to-face dimensions.*

ISO 6708:1980, *Pipe components — Definition of nominal size.*

ISO 7005-1:1992, *Metallic flanges — Part 1: Steel flanges.*

ISO 7268:1983, *Pipe components — Definition of nominal pressure.*

ANSI/ASME B1.20.1:1983, *Pipe threads, general purpose (inch).*

3 Definitions

For the purposes of this International Standard, the definition of nominal size given in ISO 6708 and of nominal pressure given in ISO 7268 apply.

1) To be published. (Revision of ISO 5208:1982)

4 Pressure/temperature ratings

4.1 The pressure/temperature ratings applicable to flanged valves specified in this International Standard shall be in accordance with those specified in ISO 7005-1 for steel flanges of the applicable nominal pressure and material specification. Restrictions of temperature and pressure, for example those imposed by soft seals and special trim materials, shall be indicated on the valve identification plate [see 8.5 c)].

4.2 The temperature shown for a corresponding pressure rating is the temperature of the pressure-containing shell of the valve. In general, this temperature is the same as that of the contained fluid. The use of a pressure rating corresponding to a temperature other than that of the contained fluid is the responsibility of the user.

4.3 For temperatures below the lowest temperature shown in the pressure/temperature rating tables in ISO 7005-1, the service pressure shall be no greater than the rating shown for that lowest temperature. The use of valves at lower temperatures is the responsibility of the user. Consideration should be given to the loss of ductility and impact strength of many materials at low temperature.

5 Design

5.1 Body wall thickness

5.1.1 The minimum body wall thickness, t_m , at the time of manufacture shall be as given in table 1, except as indicated in 5.1.2 to 5.1.4.

Additional metal thickness needed for assembly stresses, closing stresses, stress concentrations and shapes other than circular shall be determined by individual manufacturers, since these factors vary widely.

5.1.2 The weld preparation in butt-welding end valves (see 5.2.2.2) shall not reduce the body wall thickness to less than the values specified in 5.1.1 within a region closer to the outside surface of the body neck than t_m measured along the run direction. The transition to the weld preparation shall be

gradual and the section shall be essentially circular through the entire length of the transition. Sharp discontinuities or abrupt changes in section in areas that infringe into the transition shall be avoided, except that test collars or bands, either welded or integral, are allowed. In no case shall the thickness be less than $0,77t_m$ at a distance of $1,33t_m$ from the weld end.

5.1.3 The valve body neck shall maintain the minimum body wall thickness t_m as specified in 5.1.1 within the distance $1,1\sqrt{dt_m}$ measured from the outside of the body run along the neck direction, where d is the nominal inside diameter as defined in 5.2.1.4.

Beyond the distance $1,1\sqrt{dt_m}$ from the outside of the body run, straight circular sections of body necks with inside diameter d' shall be provided with a minimum local wall thickness of t' , where t' is determined, by interpolation if necessary, as the value of t_m which would correspond to a value of d equal to $2d'/3$, using the applicable nominal pressure rating.

It will be noted that for any case where $d' > 1,5d$, the newly determined minimum wall thickness for the body neck will be greater than the basic value t_m . In such cases, this greater wall thickness shall be provided for all parts of the body neck having a diameter greater than $1,5d$.

5.1.4 Local areas having less than the minimum wall thickness will be acceptable provided that all of the following limitations are satisfied:

- a) the area of less than minimum thickness can be enclosed by a circle whose diameter is no greater than $0,35\sqrt{dt_m}$, where d is the nominal inside diameter as given in table 2 and t_m is the minimum body wall thickness as shown in table 1;
- b) the measured thickness is no less than $0,75t_m$;
- c) enclosure circles are separated from each other by an edge-to-edge distance of no less than $1,75\sqrt{dt_m}$.

5.1.5 The terms used in this clause are illustrated in figure 1.

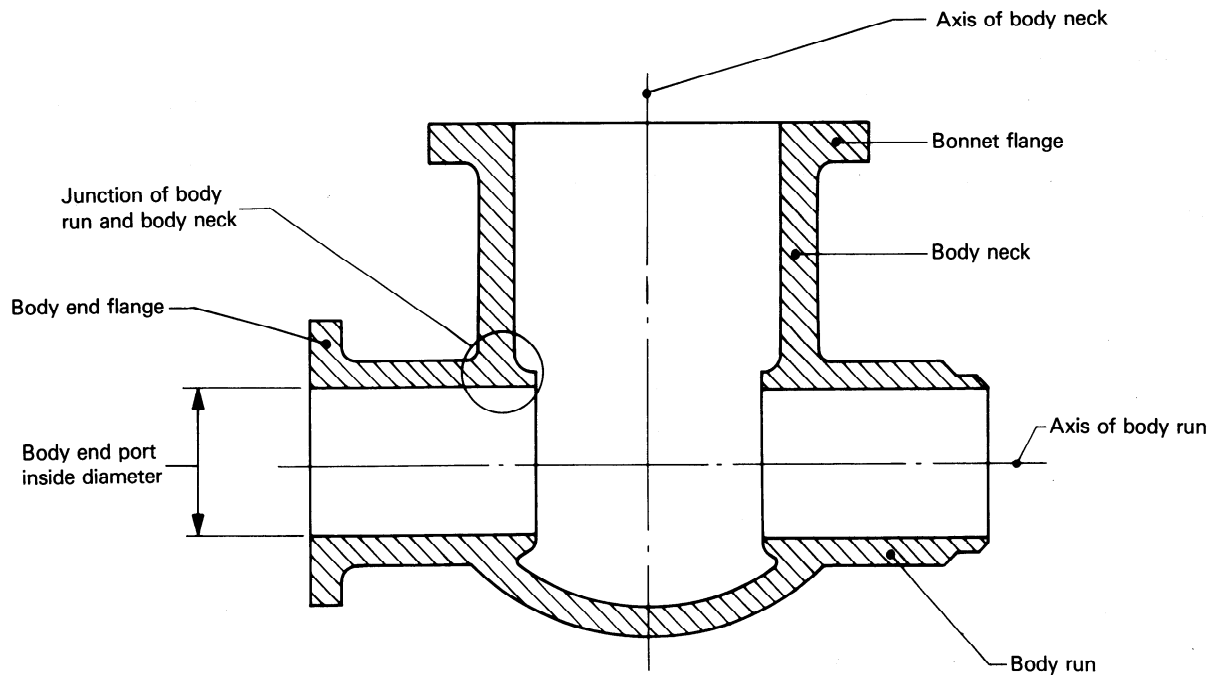

Figure 1 — Identification of terms

Table 1 — Body wall thickness

Nominal size DN ¹⁾	Nominal pressure PN						
	10	16	20	25	40	50	100
	Minimum body wall thickness t_m mm						
10	3	3	3	3	3	3	3,3
15	3	3	3	3	3,1	3,1	3,4
20	3	3	3,1	3,3	3,5	3,8	4,1
25	4	4	4,1	4,2	4,6	4,8	4,8
32	4,5	4,5	4,8	4,8	4,8	4,8	4,8
40	4,5	4,5	4,8	4,8	4,8	4,8	5,6
50	5	5,5	5,6	5,7	6,1	6,4	6,4
65	5	5,5	5,6	5,8	6,6	6,4	7,1
80	5	5,5	5,6	5,8	6,6	7,1	7,9
100	6	6	6,4	6,6	7,3	7,8	9,6
125	6,3	6,5	7,1	7,2	8,1	9,6	11,2
150	6,5	7	7,1	7,5	8,8	9,6	12,7
200	7	8	8,1	8,6	10,2	11,2	15,8
250	7,5	8,5	8,6	9,3	11,4	12,7	19
300	8,5	9,5	9,6	10,4	12,7	14,2	23,1
350	9	10	10,4	11,3	14	15,8	24,6
400	9,6	11	11,2	12,7	15,4	17,5	27,7
450	10	11,5	11,9	13	16,6	19	31
500	10,5	12,5	12,8	14,5	18,3	20,6	34
600	11,5	14	14,4	16,3	21,3	23,9	40,4
700	12,5	15,5	16	18,2	24,3	27,2	
800	14	17	17,6	20,1	27,3	30,5	
900	15,5	18,5	19,2	22	30,4	33,8	
1 000	17	20	20,8	23,9	33,5	37,2	

1) For the corresponding body end port nominal inside diameter, see table 2.

5.2 Body dimensions

5.2.1 Flanges

5.2.1.1 Face-to-face dimensions for flanged end valves shall be in accordance with ISO 5752:1982, table 3.

5.2.1.2 Body end flanges shall comply with the requirements of ISO 7005-1.

5.2.1.3 End flanges shall be cast or forged integral with the body except that flanges may be attached by welding by a qualified welding operator using a qualified welding procedure, provided that all such flanges on valves DN 50 and larger are butt-welded. Any heat treatment necessary to ensure that the material is suitable for the full range of service temperatures shall be performed.

5.2.1.4 For unlined flanged valves, the nominal inside diameter, d , of the body end port shall be as specified in table 2 as applicable.

5.2.2 Weld ends

5.2.2.1 End-to-end dimensions for butt-weld end valves shall be in accordance with table 3, unless otherwise specified in the purchase order.

5.2.2.2 Butt-welding ends shall be in accordance with the details shown in figure 2, unless otherwise specified in the purchase order.

Table 2 — Body end port nominal inside diameter d

DN	PN		
	10; 16; 20; 25	40; 50	100
	d mm		
10	10	10	10
15	13	13	13
20	19	19	19
25	25	25	25
32	32	32	32
40	38	38	38
50	50	50	50
65	64	64	64
80	76	76	76
100	100	100	100
125	125	125	125
150	150	150	150
200	200	200	200
250	250	250	250
300	300	300	300
350	335	335	325
400	385	385	375
450	430	430	420
500	485	485	465
600	585	585	560
700	690	685	650
800	795	790	
900	895	885	
1 000	990	985	

Table 3 — End-to-end dimensions (butt-weld end valves), *l*

Dimensions and tolerances in millimetres

DN	10; 16; 25		20		PN 40		50		100	
	<i>l</i>	tol.	<i>l</i>	tol.	End-to-end lengths		<i>l</i>	tol.	<i>l</i>	tol.
50	250	± 2	216	± 2	250	± 3	216	± 2	292	± 3
65	270	± 3	241		290		241		330	
80	280		283	310	283		356			
100	300		305	350	305	432				
125	325	± 3	381	± 3	400	± 3	381	± 3	508	± 4
150	350		403		450		403		559	
200	400		419		550		419		660	
250	450	± 4	457	± 4	650	± 4	457	± 4	787	± 5
300	500		502		750		502		838	
350	550		572		850		762		889	
400	600	± 4	610	± 4	950	± 5	838	± 5	991	± 6
450	650		660		1 150		914		1 092	
500	700		711		1 350		991		1 194	
600	800	± 5	813	± 5	1 350	± 6	1 143	± 6	1 397	± 6
700	900						1 143		1 397	
800	1 000						1 143		1 397	
900	1 100	± 6	1 100	± 6	1 200	± 6	1 100	± 6	1 200	± 6
1 000	1 200									

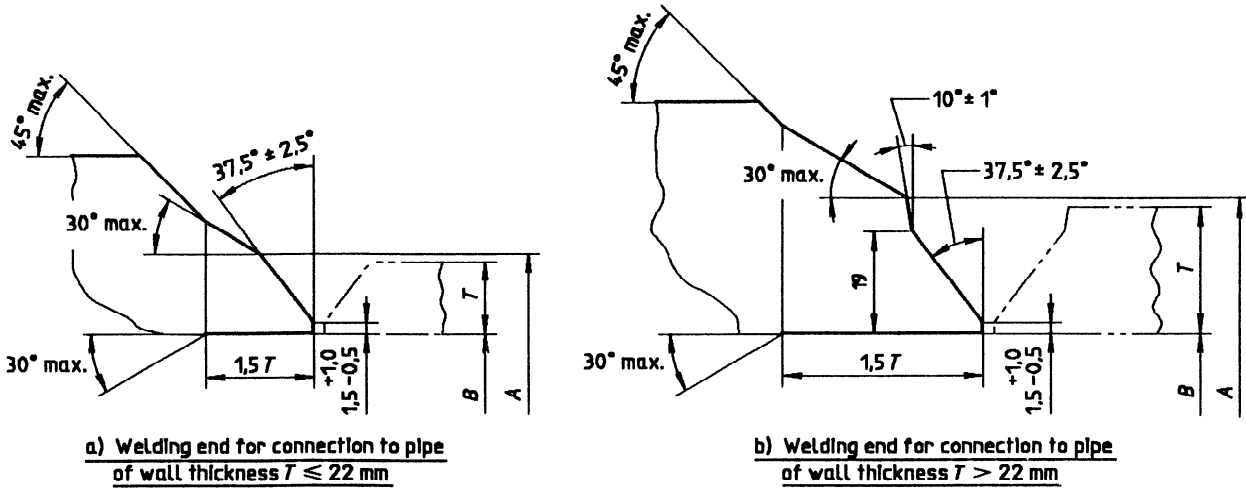

A = nominal outside diameter of welding end (see table 4)
 B = nominal inside diameter of pipe (for tolerance on B, see table 4)
 T = nominal wall thickness of pipe

NOTES

- 1 The inside and outside surfaces of valve welding ends shall be machine finished overall. The contour within the envelope is at the option of the manufacturer unless specifically ordered otherwise.
- 2 Intersections should be slightly rounded.
- 3 Valves having a minimum wall thickness $t_m \leq 3$ mm may have ends cut square or slightly chamfered.
- 4 For the nominal outside diameters and wall thicknesses of standard steel pipes, see ISO 4200:1991, *Plain end steel tubes, welded and seamless — General tables of dimensions and masses per unit length.*

Figure 2 — Weld ends

Table 4 — Dimensions and tolerances of weld ends

Dimensions and tolerances in millimetres

Valve nominal size DN	25	32	40	50	65	80	100	125	150	200	250	300	350	400	450	500	600	700	800	900	1 000	
A	nom.	35	44	50	62	78	91	117	144	172	223	278	329	362	413	464	516	619	721	825	927	1 029
	tol.	+2,5 -1,0						+4 -1														
B	tol.	+1 -1						+2 -2						+3 -2								

5.3 Auxiliary connections

5.3.1 Provision for auxiliary connections is not required unless specified in the purchase order.

5.3.2 Auxiliary connections shall be identified as indicated in figure 3. Each of the 11 locations is designated by a letter.

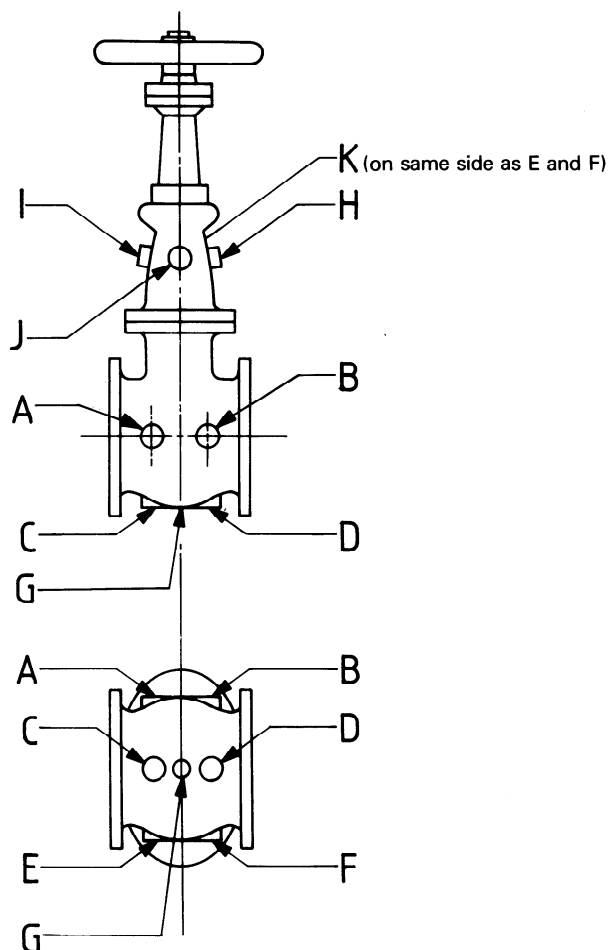

Figure 3 — Location of tappings for auxiliary connections

5.3.3 Unless otherwise specified in the purchase order, auxiliary connections shall be in accordance with table 5.

Table 5 — Sizes of auxiliary connections

Valve nominal size DN	Auxiliary connection size	
	DN	(NPS) ¹⁾
50 ≤ DN ≤ 100	15	(1/2)
125 ≤ DN ≤ 200	20	(3/4)
250 ≤ DN ≤ 600	25	(1)
650 ≤ DN	40	(1 1/2)

1) See ANSI/ASME B1.20.1.

5.3.4 When bosses are required to obtain adequate metal thickness, the inscribed diameter shall be as shown in table 6.

Table 6 — Minimum diameter of bosses

Auxiliary connection size		Minimum boss diameter mm
DN	(NPS)	
15	(1/2)	38
20	(3/4)	44
25	(1)	54
32	(1 1/4)	64
40	(1 1/2)	70

5.3.5 The wall of the valve may be tapped if the metal is thick enough to allow the effective thread length shown in figure 4 and specified in table 7. Where the thread length is insufficient or the tapped hole needs reinforcement, a boss shall be added as specified in 5.3.4. Threads shall be tapered as shown in figure 4.

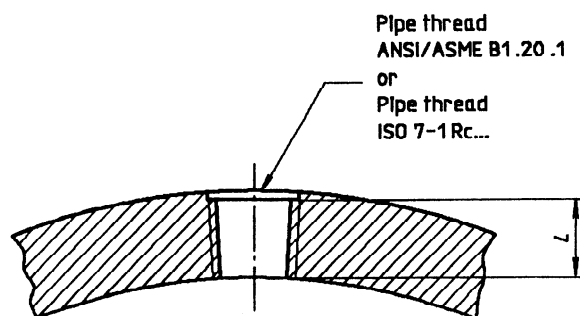

Figure 4 — Thread length for auxiliary connections

Table 7 — Minimum thread lengths for auxiliary connections

Auxiliary connection size		Minimum thread length <i>L</i> mm
DN	(NPS)	
15	(1/2)	14
20	(3/4)	14
25	(1)	18
32	(1 1/4)	18
40	(1 1/2)	19

5.3.6 Sockets, for socket welding connections, may be provided if the metal is thick enough to accommodate the depth of socket and retaining wall as specified in figure 5 and table 8. Where the wall thickness is insufficient or the socket requires reinforcement, a boss shall be added as specified in 5.3.4. The length of the leg of the attachment weld shall be 1,09 times the nominal pipe wall thickness of the auxiliary connection or 3 mm, whichever is the greater.

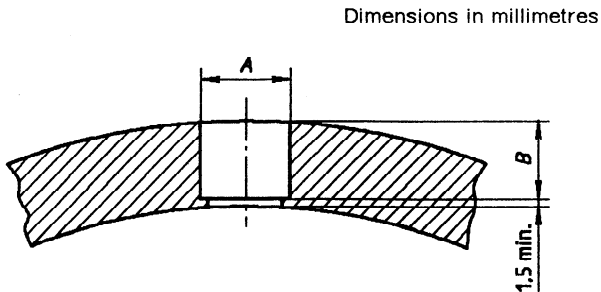

Figure 5 — Socket welding for auxiliary connections

Table 8 — Socket dimensions for socket welding connections

Auxiliary connection size		<i>A</i> _{min} mm	<i>B</i> _{min} mm
DN	(NPS)		
15	(1/2)	22	5
20	(3/4)	27	6
25	(1)	34	6
32	(1 1/4)	43	7
40	(1 1/2)	49	7

5.3.7 Auxiliary connections may be attached by butt-welding directly to the wall of the valve as illustrated in figure 6. Where the size of the opening is such that reinforcement is necessary, a boss shall be added as specified in 5.3.4.

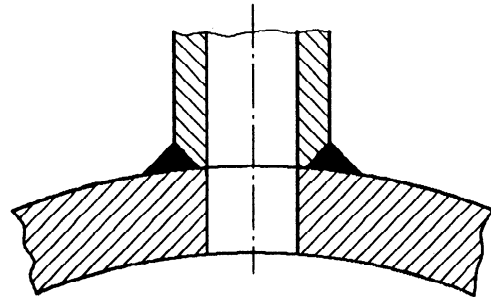
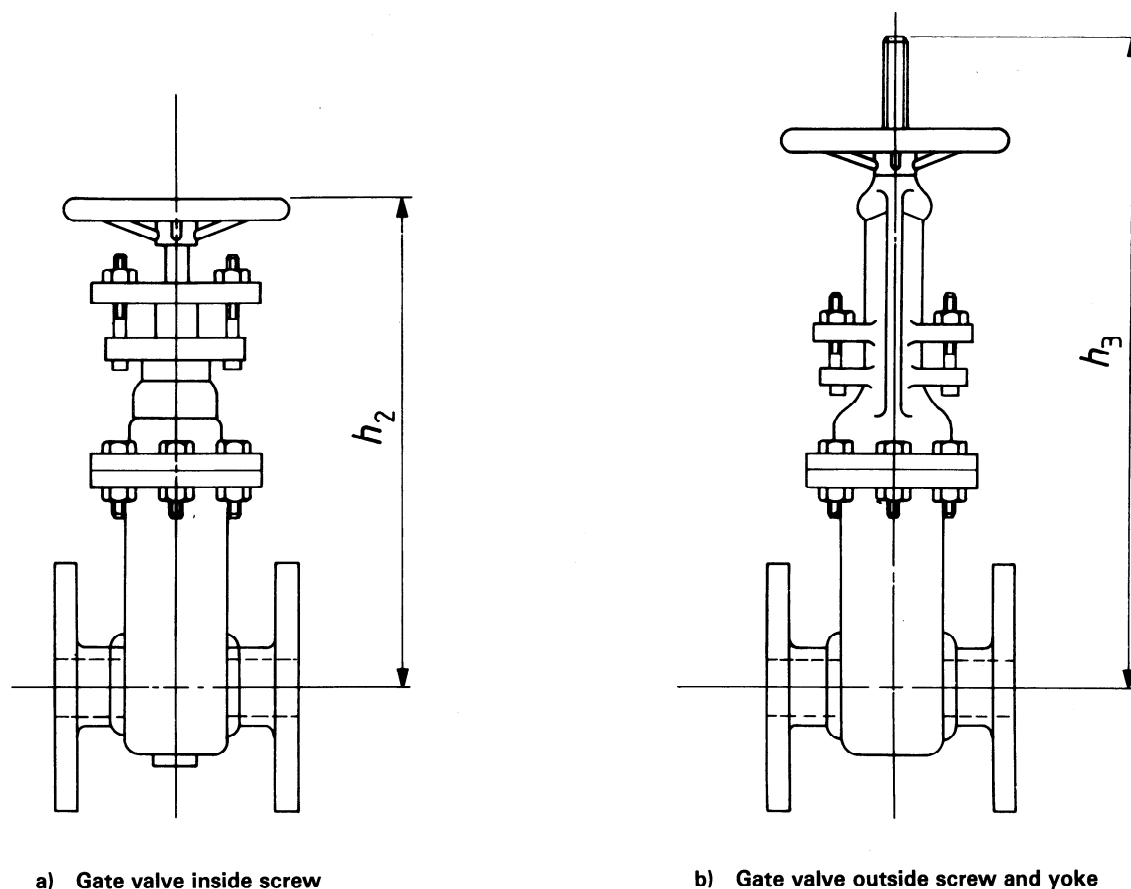

Figure 6 — Butt-welding for auxiliary connections

5.4 Envelope dimensions

Dimensions²⁾ *h*₂ and *h*₃ given in figure 7 and table 9 are dimensions for handwheel-operated valves and constitute the space necessary to ensure that the valve can be assembled into its position on site. However, the handwheel diameter may exceed the face-to-face or end-to-end dimension.

2) These dimensions are given for information only.



a) Gate valve inside screw

b) Gate valve outside screw and yoke

Figure 7 — Envelope dimensions

Table 9 — Maximum envelope dimensions

Dimensions in millimetres

DN	PN							
	10; 16; 25		20		40		50	100
	h_2	h_3	h_2	h_3	h_2	h_3	h_3	h_3
40	310	440	330	380	310	440	435	470
50	320	440	330	440	310	440	525	535
65	395	600	380	490	395	600	575	595
80	420	600	440	550	395	600	620	675
100	480	665	500	655	460	665	750	840
125	580	870	580	775	580	870	880	950
150	610	870	640	895	650	870	980	1 150
200	750	1 220	760	1 120	790	1 220	1 250	1 345
250	880	1 390	910	1 335	925	1 390	1 480	1 640
300	1 000	1 645	1 040	1 540	1 030	1 645	1 700	1 855
350	1 115	1 740	1 130	1 785	1 130	1 740	1 915	2 100
400	1 225	1 995	1 230	2 025	1 285	1 995	2 060	2 350
450	1 430	2 390		2 260	1 545	2 390	2 380	2 500
500	1 470	2 495		2 470	1 690	2 495	2 570	2 655
600	1 635	2 905		2 865	1 885	2 905	3 130	3 200
700	1 820	3 170				3 170		
800	2 120	3 620		4 265		3 620		
900		3 985				3 985		
1 000		4 380				4 380		

5.5 Operation

5.5.1 Unless otherwise specified by the purchaser, the valve shall be supplied with a handwheel. The valve shall be closed by turning the handwheel in a clockwise direction.

5.5.2 If operation by a chainwheel, gearbox or actuator is required, the purchaser shall specify, as applicable

- for chainwheel operation, the dimension from the centreline of the valve stem to the bottom of the chain loop;
- spur or bevel gear, and position of gearing relative to pipe axis;
- electric, hydraulic, pneumatic, or other actuator;
- maximum service temperature and differential pressure across the valve;
- power supply (for actuators).

Any special requirements, such as actuator mating dimensions, shall comply with ISO 5210.

5.5.3 If a limit on handwheel effort is applicable, the maximum shall be specified.

6 Materials

6.1 Materials other than trim materials

Materials for components shall be selected from table 10.

6.2 Trim

6.2.1 The trim comprises the following:

- a) a stem (thrust collars on stems for inside screw valves shall be integral with stems);

- b) obturator seat surfaces;

- c) body seat surfaces.

6.2.2 Standard trim materials shall be of the general chemical composition specified in table 11.

NOTE 1 Other trim materials are permitted by agreement between manufacturer and purchaser.

6.2.3 Stems shall be made of wrought or forged material.

Table 10 — Component materials

Component	Material
Body bonnet	To be selected from ISO 7005-1.
Soft seals	If used, any retaining ring in the obturator shall be of a material compatible with the obturator and any retaining bolting shall be of 18-8 CrNi type steel.
Obturator	Steel at least equal in corrosion resistance to that of the shell material.
Auxiliary connection plugs	Cast iron plugs shall not be used.
Yoke separate from bonnet	Carbon steel or same material as bonnet.
Handwheel	Steel Malleable iron Ductile iron
Handwheel retaining nut	Copper alloy Steel Malleable iron Ductile iron
Stem nuts	Copper alloy Stainless steel Ductile iron Malleable iron
Identification plate	Corrosion-resistant material attached to the valve by fasteners of corrosion-resistant material or by welding.

Table 11 — Standard trim materials

Location	Material	Minimum Brinell hardness	Material description
Stem	CrNi		Chromium nickel alloy
	Cr13		Steel, 11,5 % chromium min.
	NiCu		Nickel copper alloy
Seating surfaces	Cr13	250 HB ¹⁾	Steel, 11,5 % chromium min.
	HF	350 HB	HF-Hardfacing alloy
	NiCu		Nickel copper alloy
	CrNi		Chromium nickel alloy

1) A hardness differential of 50 HB is required between the body and obturator seating surfaces if both are made of Cr13.

7 Testing and inspection

7.1 Each valve shall be pressure tested in accordance with the requirements of ISO 5208, except that a shell test at no less than 1,5 times the 20 °C pressure rating is mandatory for all valve sizes.

7.2 The items shown in table 12 shall be checked on each valve by the manufacturer.

8 Marking

8.1 Legibility

Each valve manufactured in accordance with this International Standard shall be clearly marked.

8.2 Mandatory body markings

The mandatory body markings, subject to the provisions of 8.3, shall be as follows:

- manufacturer's name or trade-mark;
- body material;
- nominal pressure (PN followed by the appropriate number);

- nominal size (DN followed by the appropriate number).

8.3 Omission of body markings

For valves smaller than DN 50, if the size or shape of the valve body precludes the inclusion of all the required markings, one or more may be omitted provided that they are shown on the identification plate. The sequence of omission shall be as follows:

- nominal size (DN);
- nominal pressure (PN);
- body material.

8.4 Marking of pipe end flanges grooved for ring joints

Pipe end flanges grooved for ring joints shall be marked with the corresponding ring joint gasket number (e.g. R25). This identification shall be marked on the rim of both end flanges. For ring joint gasket numbers, see ISO 7005-1.

Table 12 — Inspection requirements

Item	Requirement
1 Type and trim The delivered valve shall comply with the order and product standard.	To check visually the type, its trim, accessories (e.g. handwheels) and other items of the order (e.g. obturator closed).
2 Marking The marking shall comply with clause 8.	To check visually that markings are complete and legible.
3 Surface condition	To examine visually prior to any coating or painting to determine that the surface is free from defects which may affect the safety and functioning of the valve.
4 Coating Where protective coatings are specified, they shall be applied.	To examine visually to determine that any specified coating has been applied.
5 Actuation	To check that the valve opens and closes properly.

8.5 Identification plate

An identification plate containing at least the following marking shall be securely attached to valves conforming to this International Standard:

- a) the number of this International Standard;
- b) the trim materials, which shall be indicated in the following order, using the appropriate symbols from table 11:
- 1) stem,
 - 2) obturator,
 - 3) seat;

EXAMPLES

Stem Cr13

Obturator HF

Seat Cr13

or

Cr13 HF Cr13

or

Cr13

HF

Cr13

- c) pressure or temperature restrictions that may be imposed by the manufacturer, due to limitations on materials or design, including at least the maximum permissible temperature and the corresponding allowable pressure.

8.6 Additional marking

Additional markings may be used at the option of the manufacturer, provided that they do not conflict with any of the markings specified in this International Standard.

This page intentionally left blank

This page intentionally left blank

This page intentionally left blank

UDC 621.646.2

Descriptors: steel products, valves, flanged valves, gate valves, specifications, dimensions, marking.

Price based on 12 pages
