International Standard



5969

INTERNATIONAL ORGANIZATION FOR STANDARDIZATION • МЕЖДУНАРОДНАЯ ОРГАНИЗАЦИЯ ПО СТАНДАРТИЗАЦИИ • ORGANISATION INTERNATIONALE DE NORMALISATION

Ground thread taps for pipe threads G series and Rp series — Tolerances on the threaded portion

Tarauts à filets rectifiés pour filetages gaz séries G et Rp — Tolérances sur la partie taillée

First edition — 1979-10-15

FOREWORD

ISO (the International Organization for Standardization) is a worldwide federation of national standards institutes (ISO member bodies). The work of developing International Standards is carried out through ISO technical committees. Every member body interested in a subject for which a technical committee has been set up has the right to be represented on that committee. International organizations, governmental and non-governmental, in liaison with ISO, also take part in the work.

Draft International Standards adopted by the technical committees are circulated to the member bodies for approval before their acceptance as International Standards by the ISO Council.

International Standard ISO 5969 was developed by Technical Committee ISO/TC 29, *Small tools*, and was circulated to the member bodies in March 1978.

It has been approved by the member bodies of the following countries :

Australia	Italy	South Africa, Rep. of
Belgium	Japan	Spain
Bulgaria	Korea, Dem. P. Rep. of	Sweden
Chile	Korea, Rep. of	Switzerland
Germany, F. R.	Mexico	Turkey
Hungary	Netherlands	United Kingdom
India	Poland	USSR
Israel	Romania	Yugoslavia

The member bodies of the following countries expressed disapproval of the document on technical grounds :

Czechoslovakia
France

Ground thread taps for pipe threads G series and Rp series — Tolerances on the threaded portion

1 Scope and field of application

This International Standard specifies the deviations and tolerances on the major diameter and the pitch diameter together with the limits of these diameters for ground thread taps intended for production of pipe threads G and Rp series according to ISO 228/1 and ISO 7/1 respectively.

The internal threads produced with these taps are conventionally designated by the simplified denomination of "nut".

2 References

ISO 7/1, *Pipe threads where pressure-tight joints are made on*

the threads — Part 1: Designation, dimensions and tolerances.

ISO 228/1, *Pipe threads where pressure-tight joints are not made on the threads — Part 1: Designation, dimensions and tolerances.*

ISO 2284, *Hand taps for pipe threads for parallel and taper threads — General dimensions and marking.*

ISO 2857, *Ground thread taps for ISO metric threads of tolerances 4H to 8H and 4G to 6G coarse and fine pitches — Manufacturing tolerances on the threaded portion.*

3 Tolerances

3.1 Basic data

3.1.1 Thread profile of nuts

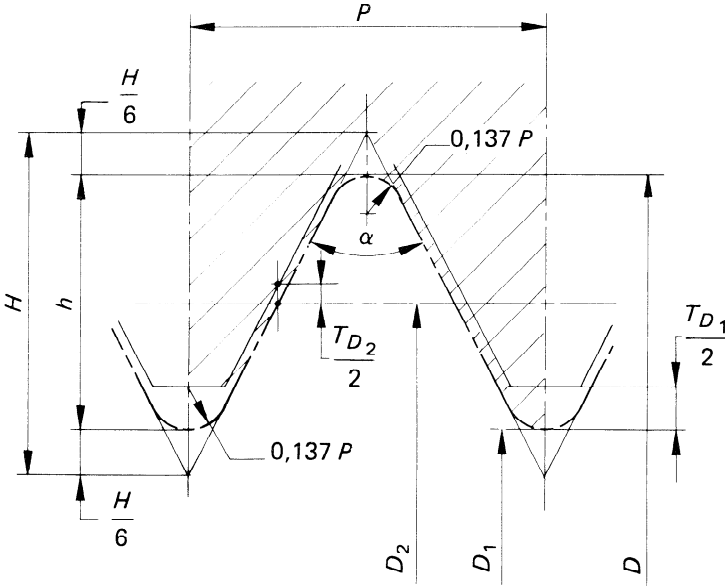

Figure 1 – G series

- D = basic major diameter
- D_1 = basic minor diameter
- D_2 = pitch diameter
- P = pitch of thread
- α = included angle of thread (55°)

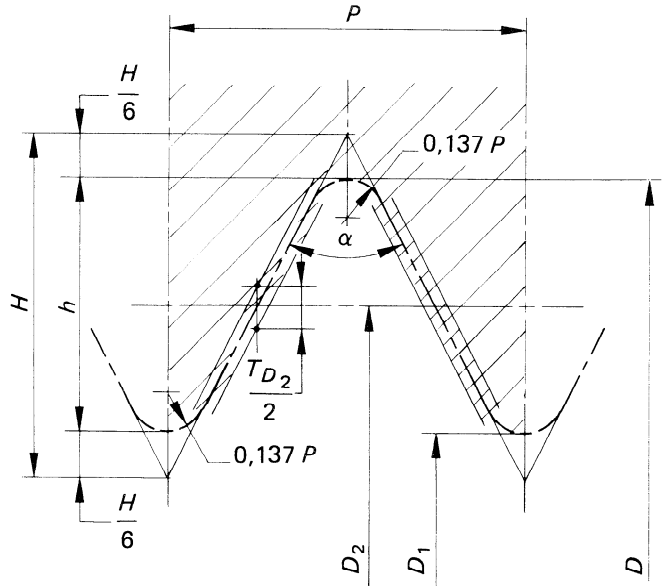

Figure 2 – Rp series

- H = height of fundamental triangle
- T_{D_1} = minor diameter tolerance
- T_{D_2} = pitch diameter tolerance
- h = basic depth of thread

3.1.2 Thread profile of taps

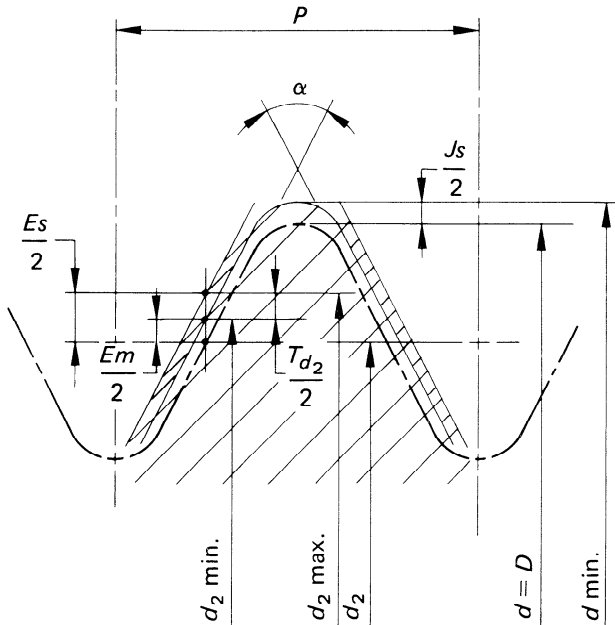

Figure 3 – G series

- $d = D$ = basic major diameter
- $d \text{ min.}$ = minimum permissible major diameter
- J_s = minimum clearance on major diameter
- $d_2 = D_2$ = pitch diameter
- $d_2 \text{ min.}$ = minimum pitch diameter

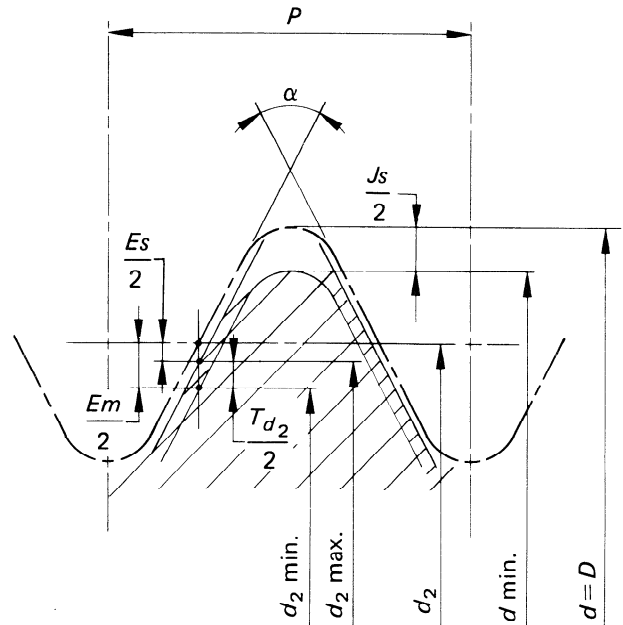

Figure 4 – Rp series

- $d_2 \text{ max.}$ = maximum pitch diameter
- E_s = upper deviation of pitch diameter
- E_m = lower deviation of pitch diameter
- T_{d_2} = tolerance on pitch diameter

3.2 Tolerance classes of taps

ISO 228/1 and ISO 7/1 each specify only one class of nut.

As a consequence, it is sufficient to have one class of taps for ISO 228/1 and another class of taps for ISO 7/1.

The tolerances of these taps are determined in terms of a tolerance unit t , the value of which is equal to the nut pitch diameter tolerance T_{D_2} .

3.3 Tolerances on pitch diameter

The minimum and maximum values of the tap pitch diameter are calculated so as to be greater than the minimum permissible value of the pitch diameter of the nut by amounts respectively equal to 0,2 times and 0,4 times the nut tolerance t .

3.3.1 Threads – G series (ISO 228/1)

The nut tolerance is a positive unilateral tolerance with zero lower deviation.

The lower deviation of the tap pitch diameter will then be $Em = + 0,2 t$ and the upper deviation $Es = + 0,4 t$ (see figure 5).

See the values of Em and Es in tables 1 and 2.

3.3.2 Threads – Rp series (ISO 7/1)

The nut tolerance is a bilateral equi-spaced tolerance.

The lower deviation of the tap pitch diameter will then be $Em = - 0,3 t$ and the upper deviation $Es = - 0,1 t$ (see figure 6).

See the values of Em and Es in tables 3 and 4.

3.4 Tolerances on major diameter

The minimum value of the tap major diameter is calculated so that it is greater than the minimum permissible value of the nut major diameter by an amount equal to a stated fraction of the tolerance t of the nut.

The upper deviation on the major diameter of the tap is not specified.

3.4.1 Threads – G series

The nut tolerance is a positive unilateral tolerance with zero lower deviation.

The lower deviation of the tap major diameter will be $J_s = + 0,3 t$ (i.e. tap diameter greater by $0,3 t$ than the nut minimum diameter).

See the values of J_s in tables 1 and 2.

3.4.2 Threads – Rp series

The nut tolerance is a bilateral equi-spaced tolerance.

The lower deviation of the tap major diameter will be $J_s = - 0,3 t$ (i.e. tap diameter greater by $0,2 t$ than the nut minimum diameter).

See the values of J_s in tables 3 and 4.

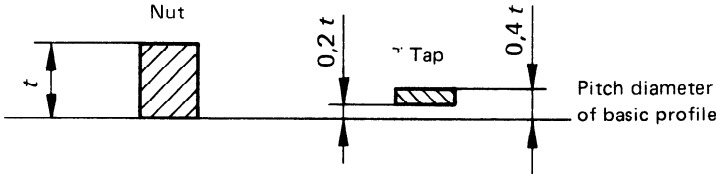

Figure 5 – Thread -- G series

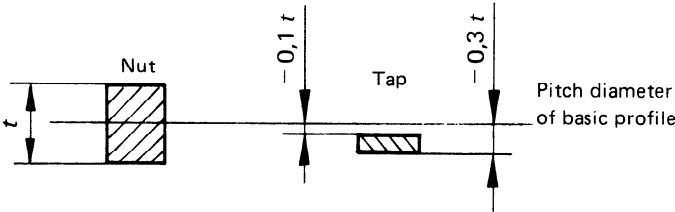

Figure 6 – Thread – Rp series

3.5 Tolerance on the angle α and the half-angle $\alpha/2$ of thread

The tolerance is $\pm 30'$ for all sizes.

4 Examples

Tables 5 and 6 show calculation examples of the dimensions of a tap G 1/2 and Rp 1/2 respectively.

Table 1 – Taps for pipe threads – G series – Dimensions in millimetres

Size designation	Basic major diameter d	Pitch	Major diameter		Basic pitch diameter d_2	Pitch diameter					
			Lower deviation $J_s = + 0,3 t$	d min.		Lower deviation $E_m = + 0,2 t$	d_2 min.	Upper deviation $E_s = + 0,4 t$	d_2 max.		
1/16	7,723	0,907	+ 0,032	7,755	7,142	+ 0,021	7,163	+ 0,043	7,185		
1/8	9,728			9,760			9,147		9,168	9,190	
1/4	13,157	1,337	+ 0,037	13,194	12,301	+ 0,025	12,326	+ 0,050	12,351		
3/8	16,662			16,699			15,806		15,831	15,856	
1/2	20,955	1,814	+ 0,043	20,998	19,793	+ 0,028	19,821	+ 0,057	19,850		
5/8	22,911			22,954			21,749		21,777	21,806	
3/4	26,441			26,484			25,279		25,307	25,336	
7/8	30,201			30,244			29,039		29,067	29,096	
1	33,249	2,309	+ 0,054	33,303	31,770	+ 0,036	31,806	+ 0,072	31,842		
1 1/8	37,897			37,951			36,418		36,454	36,490	
1 1/4	41,910			41,964			40,431		40,467	40,503	
1 1/2	47,803			47,857			46,324		46,360	46,395	
1 3/4	53,746			53,800			52,267		52,303	52,339	
2	59,614		59,668	58,135	58,171	58,207					
2 1/4	65,710		+ 0,065		65,775	64,231	+ 0,043	64,274	+ 0,087	64,318	
2 1/2	75,184				75,249			73,705		73,748	73,792
2 3/4	81,534				81,599			80,055		80,098	80,142
3	87,884				87,949			86,405		86,448	86,492
3 1/2	100,330	100,395			98,851			98,894		98,938	
4	113,030	113,095	111,551	111,594	111,638						
4 1/2	125,730	125,795	124,251	124,294	124,338						
5	138,430	138,495	136,951	136,994	137,038						
5 1/2	151,130	151,195	149,651	149,694	149,738						
6	163,830	163,895	162,351	162,394	162,438						

Table 2 — Taps for pipe threads — G series — Dimensions in inches

Size designation	Basic major diameter d	Number of threads per inch	Major diameter		Basic pitch diameter d_2	Pitch diameter				
			Lower deviation $J_s = + 0,3 t$	d min.		Lower deviation $E_m = + 0,2 t$	d_2 min.	Upper deviation $E_s = + 0,4 t$	d_2 max.	
1/16	0.304 0	28	+ 0.001 3	0.305 3	0.281 1	+ 0.000 8	0.281 9	+ 0.001 7	0.282 8	
1/8	0.383 0			0.384 3	0.360 1		0.360 9		0.361 8	
1/4	0.518 0	19	+ 0.001 5	0.519 5	0.484 3	+ 0.001 0	0.485 3	+ 0.002 0	0.486 3	
3/8	0.656 0			0.657 5	0.622 3		0.623 3		0.624 3	
1/2	0.825 0	14	+ 0.001 7	0.826 7	0.779 3	+ 0.001 1	0.780 4	+ 0.002 2	0.781 5	
5/8	0.902 0			0.903 7	0.856 3		0.857 4		0.858 5	
3/4	1.041 0			1.042 7	0.995 3		0.996 4		0.997 5	
7/8	1.189 0			1.190 7	1.143 3		1.144 4		1.145 5	
1	1.309 0	11	+ 0.002 1	1.311 1	1.250 8	+ 0.001 4	1.252 2	+ 0.002 8	1.253 6	
1 1/8	1.492 0			1.494 1	1.433 8		1.435 2		1.436 6	
1 1/4	1.650 0			1.652 1	1.591 8		1.593 2		1.594 6	
1 1/2	1.882 0			1.884 1	1.823 8		1.825 2		1.826 6	
1 3/4	2.116 0			2.118 1	2.057 8		2.059 2		2.060 6	
2	2.347 0		2.349 1	2.288 8	2.290 2	2.291 6				
2 1/4	2.587 0		+ 0.002 6		2.589 6	2.528 8	+ 0.001 7	2.530 5	+ 0.003 4	2.532 2
2 1/2	2.960 0				2.962 6	2.901 8		2.903 5		2.905 2
2 3/4	3.210 0				3.212 6	3.151 8		3.153 5		3.155 2
3	3.460 0				3.462 6	3.401 8		3.403 5		3.405 2
3 1/2	3.950 0	3.952 6			3.891 8	3.893 5		3.895 2		
4	4.450 0			4.452 6	4.391 8		4.393 5		4.395 2	
4 1/2	4.950 0			4.952 6	4.891 8		4.893 5		4.895 2	
5	5.450 0			5.452 6	5.391 8		5.393 5		5.395 2	
5 1/2	5.950 0			5.952 6	5.891 8		5.893 5		5.895 2	
6	6.450 0			6.452 6	6.391 8		6.393 5		6.395 2	

Table 3 – Taps for pipe threads – Rp series – Dimensions in millimetres

Size designation	Basic major diameter <i>d</i>	Pitch	Major diameter		Basic pitch diameter <i>d</i> ₂	Pitch diameter			
			Lower deviation <i>J</i> _s = - 0,3 <i>t</i>	<i>d</i> min.		Lower deviation <i>E</i> _m = - 0,3 <i>t</i>	<i>d</i> ₂ min.	Upper deviation <i>E</i> _s = - 0,1 <i>t</i>	<i>d</i> ₂ max.
1/16	7,723	0,907	- 0,043	7,680	7,142	- 0,043	7,099	- 0,014	7,128
1/8	9,728			9,865	9,147		9,104		9,133
1/4	13,157	1,337	- 0,063	13,094	12,301	- 0,063	12,238	- 0,021	12,280
3/8	16,662			16,599	15,806		15,743		15,785
1/2	20,955	1,814	- 0,086	20,869	19,793	- 0,086	19,707	- 0,029	19,764
3/4	26,441			26,355	25,279		25,193		25,250
1	33,249	2,309	- 0,109	33,140	31,770	- 0,109	31,661	- 0,037	31,733
1 1/4	41,910			41,801	40,431		40,322		40,394
1 1/2	47,803			47,694	46,324		46,215		46,287
2	59,614			59,505	58,135		58,026		58,098
2 1/2	75,184		- 0,130	75,054	73,705	- 0,130	73,575	- 0,043	73,662
3	87,884			87,754	86,405		86,275		86,362
4	113,030			112,900	111,551		111,421		111,508
5	138,430			138,300	136,951		136,821		136,908
6	163,830	163,700	162,351	162,221	162,308				

Table 4 – Taps for pipe threads – Rp series – Dimensions in inches

Size designation	Basic major diameter <i>d</i>	Number of threads per inch	Major diameter		Basic pitch diameter <i>d</i> ₂	Pitch diameter			
			Lower deviation <i>J</i> _s = - 0,3 <i>t</i>	<i>d</i> min.		Lower deviation <i>E</i> _m = - 0,3 <i>t</i>	<i>d</i> ₂ min.	Upper deviation <i>E</i> _s = - 0,1 <i>t</i>	<i>d</i> ₂ max.
1/16	0.304 0	28	- 0.001 7	0.302 3	0.281 2	- 0.001 7	0.279 5	- 0.000 6	0.280 6
1/8	0.383 0			0.381 3	0.360 1		0.358 4		0.359 5
1/4	0.518 0	19	- 0.002 5	0.515 5	0.484 3	- 0.002 5	0.481 8	- 0.000 9	0.483 4
3/8	0.656 0			0.653 5	0.622 3		0.619 8		0.621 4
1/2	0.825 0	14	- 0.003 4	0.821 6	0.779 3	- 0.003 4	0.775 9	- 0.001 2	0.778 1
3/4	1.041 0			1.037 6	0.995 3		0.991 9		0.994 1
1	1.309 0	11	- 0.004 3	1.304 7	1.250 8	- 0.004 3	1.246 5	- 0.001 5	1.249 3
1 1/4	1.650 0			1.645 7	1.591 8		1.587 5		1.590 3
1 1/2	1.982 0			1.877 7	1.823 8		1.819 5		1.822 3
2	2.347 0			2.342 7	2.288 8		2.284 5		2.287 3
2 1/2	2.960 0		- 0.005 1	2.954 9	2.901 8	- 0.005 1	2.896 7	- 0.001 7	2.900 1
3	3.460 0			3.454 9	3.401 8		3.396 7		3.400 1
4	4.450 0			4.444 9	4.391 8		4.386 7		4.390 1
5	5.450 0			5.444 9	5.391 8		5.386 7		5.390 1
6	6.450 0	6.444 9	6.391 8	6.386 7	6.390 1				

Table 5 — Example : Calculation of the dimensions of the threaded portion of a G 1/2 ground thread tap

Tap designation	G 1/2
Tap characteristics	Basic major diameter = $d = D = 20,955$ mm Pitch = 1,814 mm Thread length = 26 mm
Minimum major diameter	$d_{\min.} = d + J_s = d + 0,3 t$ $d = 20,955$ mm $J_s = 0,3 t = 0,043$ mm $d_{\min.} = 20,955 + 0,043 = 20,998$ mm
Basic pitch diameter	$d_2 = D_2 = 19,793$ mm
Minimum pitch diameter	$d_2_{\min.} = d_2 + E_m = d_2 + 0,2 t$ $d_2 = 19,793$ mm $E_m = 0,2 t = 0,028$ mm $d_2_{\min.} = 19,793 + 0,028 = 19,821$ mm
Maximum pitch diameter	$d_2_{\max.} = d_2 + E_s = d_2 + 0,4 t$ $d_2 = 19,793$ mm $E_s = 0,4 t = 0,057$ mm $d_2_{\max.} = 19,793 + 0,057 = 19,850$ mm
Minor diameter	Not specified
Tolerance on angle α and half-angle $\alpha/2$	$\pm 30'$
Cumulative pitch error, T_p , over any number of threads	As in ISO 2857

Table 6 — Example : Calculation of the dimensions of the threaded portion of an Rp 1/2 ground thread tap

Tap designation	Rp 1/2
Tap characteristics	Basic major diameter $d = D = 20,955$ mm Pitch = 1,814 mm Thread length = 26 mm
Minimum major diameter	$d_{\min.} = d - J_s = d - 0,3 t$ $d = 20,955$ mm $J_s = 0,3 t = 0,086$ mm $d_{\min.} = 20,955 - 0,086 = 20,869$ mm
Basic pitch diameter	$d_2 = D_2 = 19,793$ mm
Minimum pitch diameter	$d_2_{\min.} = d_2 - E_m = d_2 - 0,3 t$ $d_2 = 19,793$ mm $E_m = 0,3 t = 0,086$ mm $d_2_{\min.} = 19,793 - 0,086 = 19,707$ mm
Maximum pitch diameter	$d_2_{\max.} = d_2 - E_s = d_2 - 0,1 t$ $d_2 = 19,793$ mm $E_s = 0,1 t = 0,029$ mm $d_2_{\max.} = 19,793 - 0,029 = 19,764$ mm
Minor diameter	Not specified
Tolerance on angle α and half-angle $\alpha/2$	$\pm 30'$
Cumulative pitch error, T_p , over any number of threads	As in ISO 2857

This page intentionally left blank

This page intentionally left blank

This page intentionally left blank