

INTERNATIONAL
STANDARD

ISO
5902

Second edition
2013-03-01

Alpine skis — Determination of elastic properties

Skis alpins — Détermination des caractéristiques élastiques



Reference number
ISO 5902:2013(E)

© ISO 2013



COPYRIGHT PROTECTED DOCUMENT

© ISO 2013

All rights reserved. Unless otherwise specified, no part of this publication may be reproduced or utilized otherwise in any form or by any means, electronic or mechanical, including photocopying, or posting on the internet or an intranet, without prior written permission. Permission can be requested from either ISO at the address below or ISO's member body in the country of the requester.

ISO copyright office
Case postale 56 • CH-1211 Geneva 20
Tel. + 41 22 749 01 11
Fax + 41 22 749 09 47
E-mail copyright@iso.org
Web www.iso.org

Published in Switzerland

Contents

	Page
Foreword	iv
1 Scope	1
2 Normative references	1
3 Terms and definitions	1
4 Apparatus	2
5 Sampling and conditioning	4
6 Procedure	4
6.1 Determination of centre spring constant, c_M	4
6.2 Determination of shovel spring constant, c_S	5
6.3 Determination of rear spring constant, c_R	6
6.4 Determination of spring constant balance, B (forebody and afterbody spring constants)...	6
6.5 Determination of forebody torsional spring constant, c_{TB} , and afterbody torsional spring constant, c_{TA}	7
7 Expression of results	8
8 Tolerances	8
9 Test report	9

Foreword

ISO (the International Organization for Standardization) is a worldwide federation of national standards bodies (ISO member bodies). The work of preparing International Standards is normally carried out through ISO technical committees. Each member body interested in a subject for which a technical committee has been established has the right to be represented on that committee. International organizations, governmental and non-governmental, in liaison with ISO, also take part in the work. ISO collaborates closely with the International Electrotechnical Commission (IEC) on all matters of electrotechnical standardization.

International Standards are drafted in accordance with the rules given in the ISO/IEC Directives, Part 2.

The main task of technical committees is to prepare International Standards. Draft International Standards adopted by the technical committees are circulated to the member bodies for voting. Publication as an International Standard requires approval by at least 75 % of the member bodies casting a vote.

Attention is drawn to the possibility that some of the elements of this document may be the subject of patent rights. ISO shall not be held responsible for identifying any or all such patent rights.

ISO 5902 was prepared by Technical Committee ISO/TC 83, *Sports and recreational equipment*, Subcommittee SC 4, *Snowsports equipment*.

This second edition cancels and replaces the first edition (ISO 5902:1980), which has been technically revised.

Alpine skis — Determination of elastic properties

1 Scope

This International Standard specifies laboratory measurement methods to determine the elastic properties of alpine skis. Its purpose is to calculate the resistance of defined parts of the ski to bending and torsion.

The standard measurement procedures are recommended in order to ensure comparability between laboratory measurement data determined and published by ski manufacturers, institutions and others. In this International Standard no attempt is made to relate the measurement data to the quality of the ski.

2 Normative references

The following documents, in whole or in part, are normatively referenced in this document and are indispensable for its application. For dated references, only the edition cited applies. For undated references, the latest edition of the referenced document (including any amendments) applies.

ISO 6289, *Skis — Vocabulary*

3 Terms and definitions

For the purposes of this document, the following terms and definitions apply.

3.1

spring constant

c

ratio of the force F applied to the ski, to the corresponding deflection f :

$$c = \frac{F}{f}$$

Note 1 to entry: Depending on the individual parts of the ski on which the force F is applied, one can define:

- the centre spring constant, c_M ;
- the shovel spring constant, c_S ;
- the rear spring constant, c_R ;
- the afterbody spring constant, c_A ;
- the forebody spring constant, c_B .

Note 2 to entry: See [Figure 1](#).

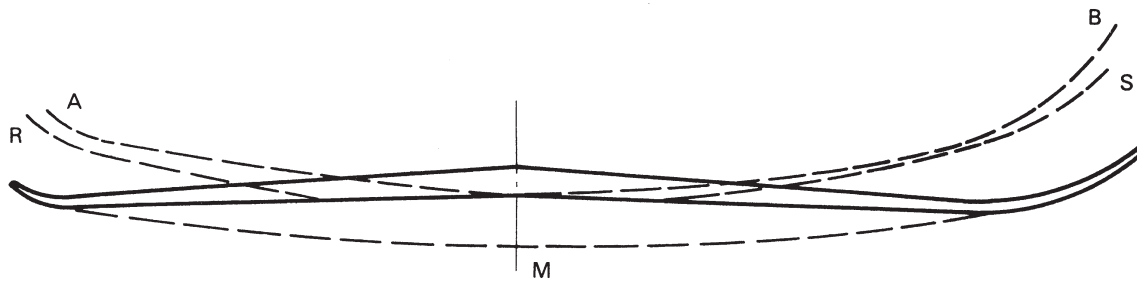

Key

- A afterbody spring bending line
- B forebody spring bending line
- M centre spring bending line
- R rear spring bending line
- S shovel spring bending line

Figure 1 — Indices for spring constants

**3.2
spring constant balance**

B
ratio of the afterbody spring constant, c_A , to the forebody spring constant, c_B

$$B = \frac{c_A}{c_B}$$

**3.3
torsional spring constant**

c_T
ratio of the torque applied to the ski to the corresponding torsion angle α

$$c_T = \frac{M}{\alpha}$$

4 Apparatus

4.1 The apparatus for measuring the centre spring constant shall consist of the following items.

4.1.1 Two adjustable supports with low-friction rollers of 20 mm diameter and wide enough to ensure that the test ski can be supported on its whole width. One of the supports with low-friction rollers has a device for clamping the end of the ski.

4.1.2 A load application device with an accuracy of ± 2 N for application of the test force F_M mid-way between the supports, which are placed at a distance that is adjustable between 1 200 and 1 720 mm, by means of a contact ram with a radius of 10 mm and a width touching the whole width of the test ski.

4.1.3 A linear measuring device for measuring the deflection f with an accuracy of $\pm 0,5$ mm.

4.2 The apparatus for measuring the shovel, rear, afterbody and forebody spring constants shall consist of the following items.

4.2.1 A clamping device, consisting of a flat jaw and three clamps, ensuring that the whole width of the ski can be clamped (see [Figure 2](#)).

4.2.2 A load application device with an accuracy of ± 2 N for application of the test forces F_S , F_R , F_A or F_B at a distance that is adjustable between 330 mm and 860 mm from the edge of the flat jaw of the clamping device by means of a low-friction roller of 20 mm diameter and wide enough to touch the whole width of the test ski.

4.2.3 A linear measuring device as specified in 4.1 c).

Dimensions in millimetres

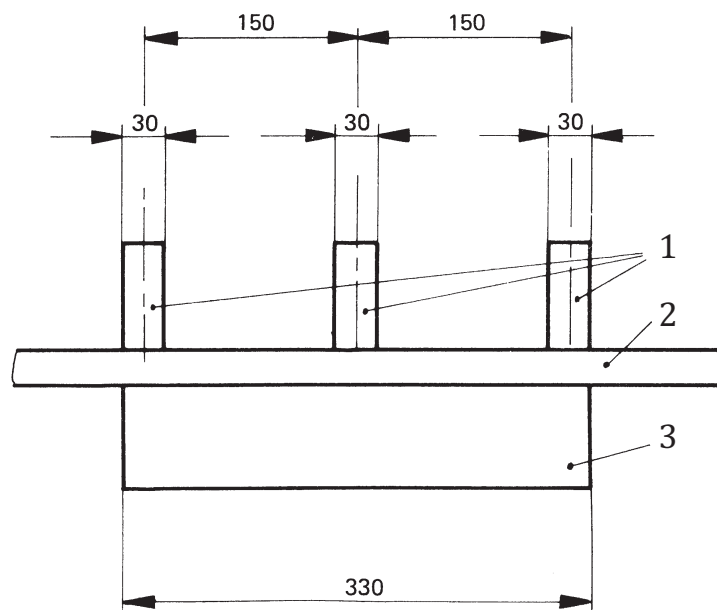

Key

- 1 clamps
- 2 test ski
- 3 flat jaw

Figure 2 — Clamping device for bending and torque tests of alpine ski — Minimal dimensions

4.3 The apparatus for measuring the torsional spring constant shall consist of the following items.

4.3.1 A clamping device as specified in 4.2 a) and shown in [Figure 2](#).

4.3.2 A torsion head of low friction with an accuracy of ± 2 N·m for application of the torque M at a distance, adjustable between 610 mm and 860 mm from the edge of the flat jaw of the clamping device. The clamping device of the torsion head holds the running surface at the same level as the clamping device of the centre of the ski (see [Figure 3](#)).

4.3.3 A scale to read the torsion angle with an accuracy of $\pm 0,5^\circ$.

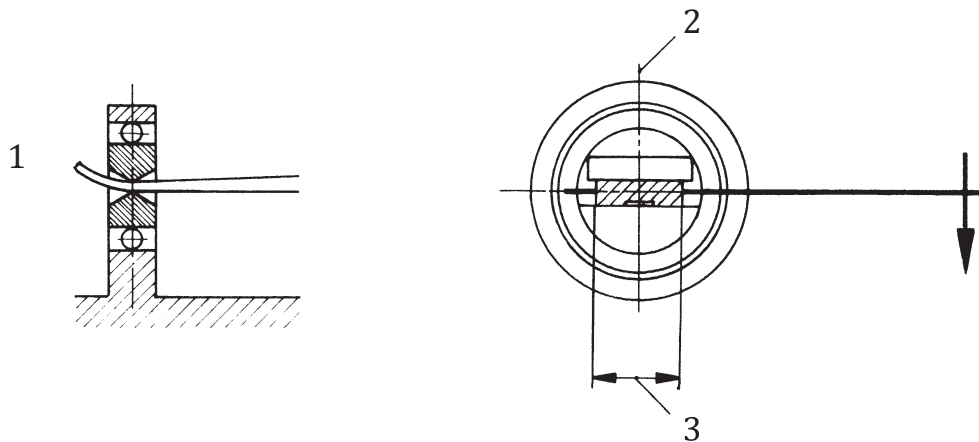

Key

- 1 test ski
- 2 ski axis
- 3 width of ski

Figure 3 — Torsion head for the torque test of alpine ski

5 Sampling and conditioning

All measurements according to this International Standard shall be taken from a finished ski without any mounted parts.

It is recommended that one of the following sizes of ski be used:

150, 180 or 200 cm.

From these three sizes shall be selected the size that is nearest in length to the model that is submitted for testing.

Before testing, the test ski shall be conditioned for at least 2 h at a temperature of $23\text{ °C} \pm 5\text{ °C}$.

6 Procedure

6.1 Determination of centre spring constant, c_M

Determine the nominal length, L_N , in accordance with ISO 6289. Place the ski on two supports set at a distance of $L_N - 280\text{ mm}$ using the apparatus specified in 4.1 and clamp at a distance of 50 mm from the end of the ski (see Figure 4). It is allowed for certain models to change the 50 mm and this shall be mentioned in the test report.

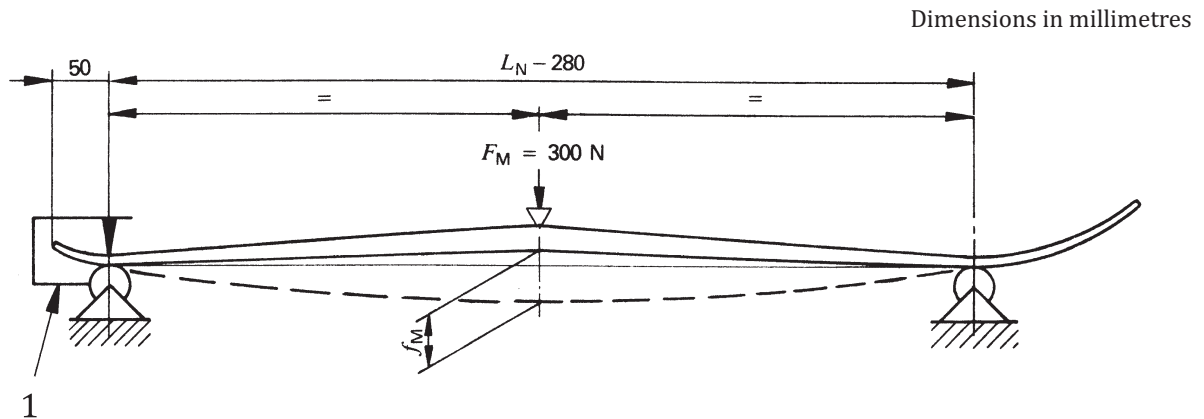
**Key**

1 clamping device

Figure 4 — Determination of centre spring constant, c_M

Apply a pre-load of 20 N. Load the ski quasi-statically with the rate of deflection less than 20 mm/min, with a test load of $F_M = 300$ N. Read the deflection, f_M , in millimetres, caused by the test load, F_M , within 2 s to 5 s after the test load has been applied.

6.2 Determination of shovel spring constant, c_S

Clamp the ski in the apparatus specified in 4.2 at a projected distance of 120 mm between ski tip and load application roller, after having set a distance of $0,3 L_N - 120$ mm between the clamping device and the load application roller, as shown in Figure 5. It is allowed for certain models to change the 120 mm and this shall be mentioned in the test report.

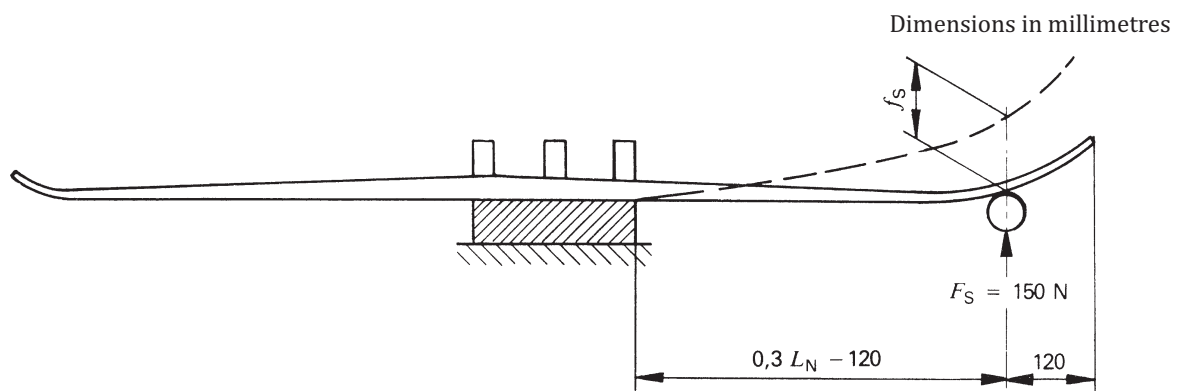
**Figure 5 — Determination of shovel spring constant, c_S**

Apply a pre-load of 20 N. Load the ski quasi-statically, with the rate of deflection less than 20 mm/min, with a test load of $F_S = 150$ N. If the deflection is more than 50 mm, the load should be reduced to 100 N. Read the deflection, f_S , in millimetres, caused by the test load F_S , within 2 s to 5 s after the test load has been applied.

6.3 Determination of rear spring constant, c_R

Clamp the ski in the apparatus specified in 4.2 at a projected distance of 10 mm between the ski tail and the load application roller, after having set a distance of $0,3 L_N - 120$ mm between the clamping device and the load application roller, as shown in Figure 6. It is allowed for certain models to change the 10 mm and this shall be mentioned in the test report. For a ski with high tail turn up, the load application point is found by determining the point of the running surface which is 5 mm above a flat standing surface and 10 mm forward from that point.

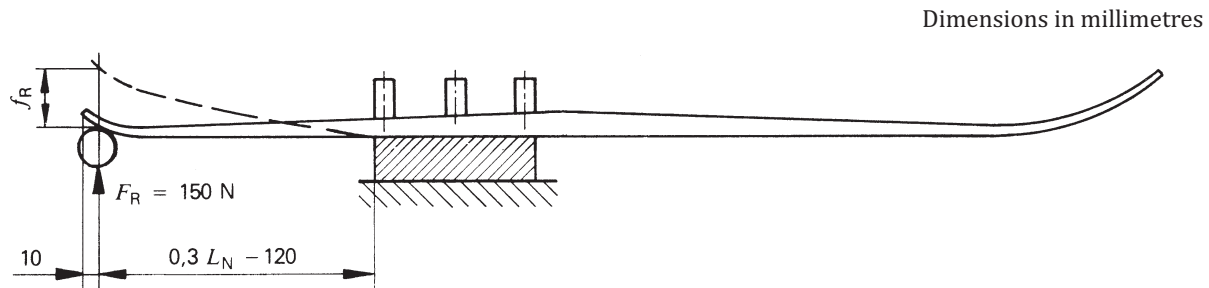

Figure 6 — Determination of rear spring constant, c_R

Apply a pre-load of 20 N. Load the ski quasi-statically with the rate of deflection less than 20 mm/min, with a test load of $F_S = 150$ N. If the deflection is more than 50 mm, the load should be reduced to 100 N. Read the deflection f_R , in millimetres, caused by the test load F_R within 2 s to 5 s after the test load has been applied.

6.4 Determination of spring constant balance, B (forebody and afterbody spring constants)

Make two bending tests, loading first the afterbody and then the forebody of the ski. Use the apparatus specified in 4.2, setting the clamping device and the load application roller at a distance of $0,5 L_N - 140$ mm. The clamping point for the afterbody spring constant as well as for the forebody spring constant shall be $0,5 L_N - 140$ mm + 50 mm from the ski tail (see Figure 7). Mount the ski on the clamping device in such a way that the ski afterbody or ski forebody can be bent freely from the clamping point. It is allowed for certain models to change the 50 mm and this shall be mentioned in the test report.

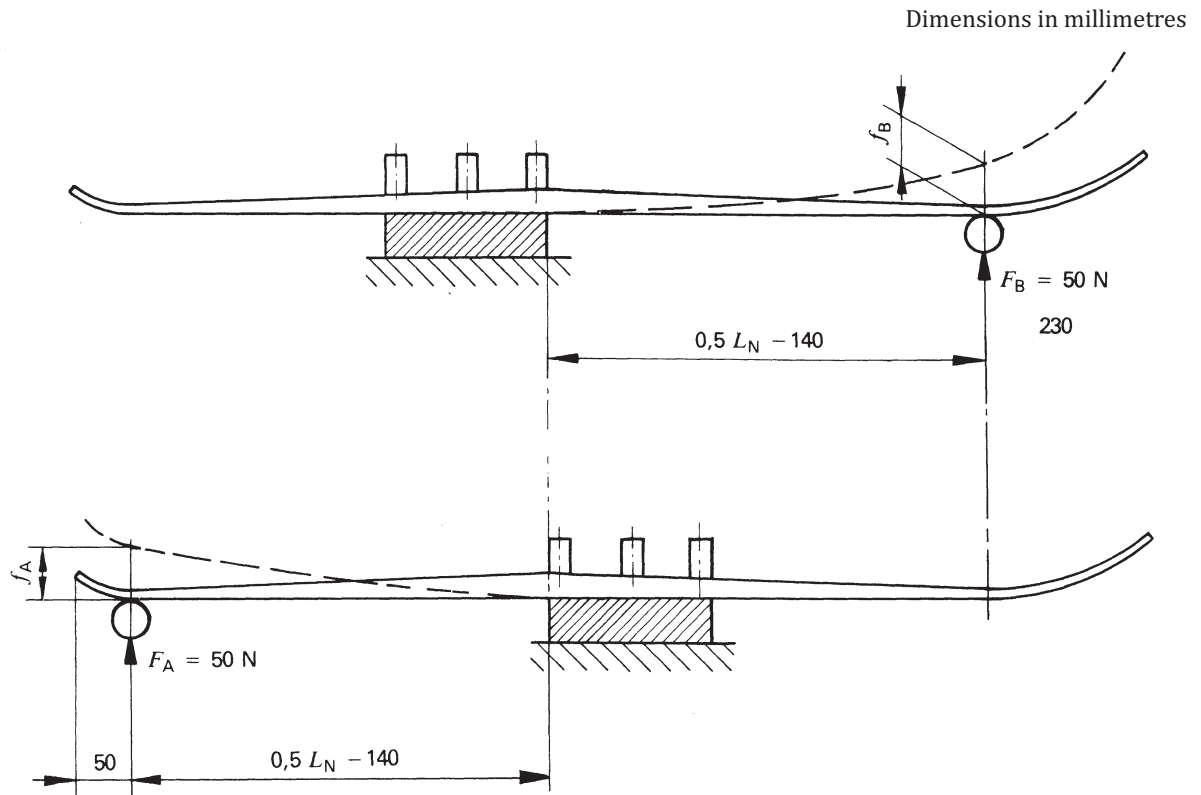

Figure 7 — Determination of spring constant balance, B (forebody and afterbody spring constants)

Apply a pre-load of 20 N. Load the ski quasi-statically with the rate of deflection less than 20 mm/min, with a test load of F_A or $F_B = 50$ N. Read the deflection f_A or f_S caused by the test load F_A or F_B within 2 s to 5 s after the test load has been applied.

6.5 Determination of forebody torsional spring constant, c_{TB} , and afterbody torsional spring constant, c_{TA}

Use the apparatus specified in 4.3, setting a distance of $0,5 L_N - 140$ mm between the clamping device and the torsion head. Clamp the ski in the measurement device as shown in Figure 8. The axis of the ski shall be in the centre of the torsion head.

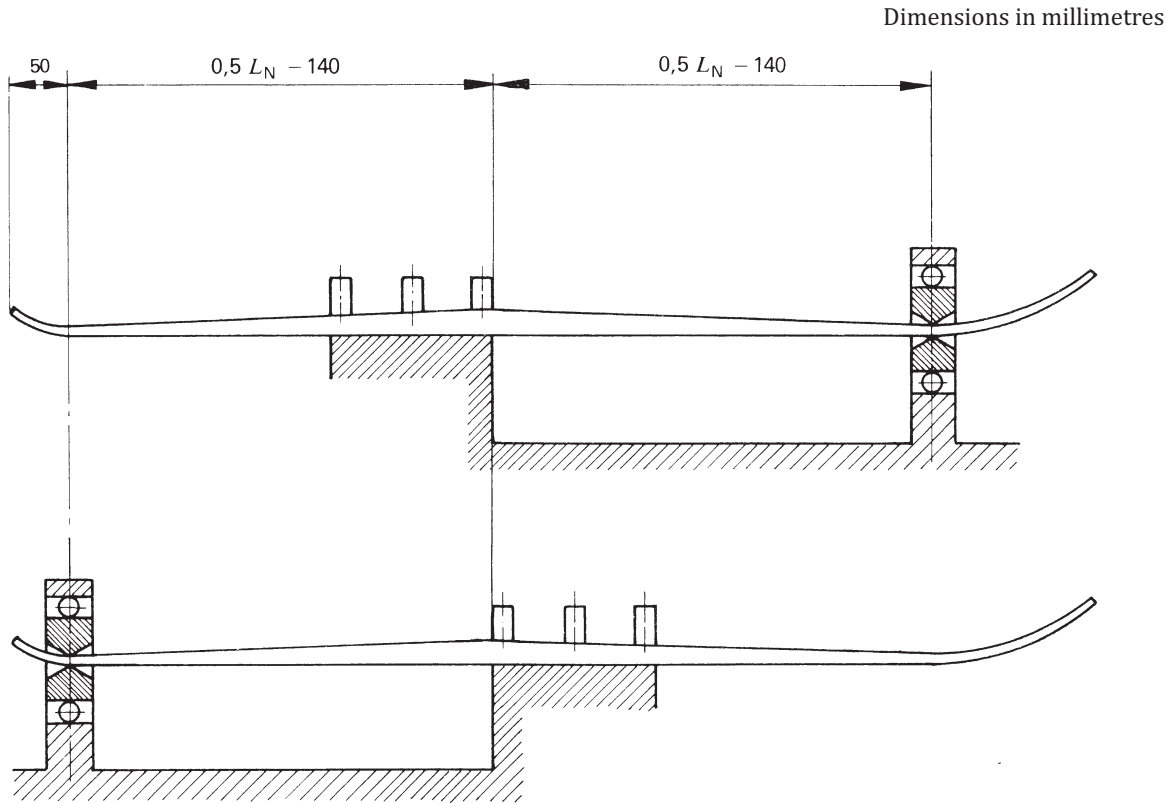

Figure 8 — Determination of forebody torsional spring constant, c_{TB} , and afterbody torsional spring constant, c_{TA}

Apply a torque quasi-statically with the rate of deflection less than 20 mm/min, (in the case of very stiff skis a torque of 20 N·m is recommended if the torsion angle is less than 5°). Read the torsion angle within 2 s to 5 s after the torque has been applied.

7 Expression of results

For each property, calculate the single results of three tests, in accordance with [Clause 3](#), recording their mean. Recommended units are given in Table 1.

Table 1 — Recommended units

Characteristic	Unit
Spring constant, c	N/mm
Torsional spring constant, c_T	N·m/°

8 Tolerances

If data are published by the manufacturer with reference to this International Standard, the following tolerances shall be observed:

- spring constant $\pm 10\%$
- torsional spring constant $\pm 10\%$

9 Test report

The test report shall include the following particulars:

- a) reference to this International Standard, i.e. ISO 5902;
- b) name or trademark of the manufacturer;
- c) model designation;
- d) nominal length;
- e) manufacturer's registration number;
- f) test results;
- g) any deviation from this International Standard with an explanation of the reason for the deviation.

