

---

---

**Aerospace — Bolts, with MJ threads,  
made of alloy steel, strength class  
1 250 MPa — Procurement specification**

*Aéronautique et espace — Vis à filetages MJ, en acier allié, de classe  
de résistance 1 250 MPa — Spécification d'approvisionnement*



Reference number  
ISO 5857:2008(E)

© ISO 2008

**PDF disclaimer**

This PDF file may contain embedded typefaces. In accordance with Adobe's licensing policy, this file may be printed or viewed but shall not be edited unless the typefaces which are embedded are licensed to and installed on the computer performing the editing. In downloading this file, parties accept therein the responsibility of not infringing Adobe's licensing policy. The ISO Central Secretariat accepts no liability in this area.

Adobe is a trademark of Adobe Systems Incorporated.

Details of the software products used to create this PDF file can be found in the General Info relative to the file; the PDF-creation parameters were optimized for printing. Every care has been taken to ensure that the file is suitable for use by ISO member bodies. In the unlikely event that a problem relating to it is found, please inform the Central Secretariat at the address given below.



**COPYRIGHT PROTECTED DOCUMENT**

© ISO 2008

All rights reserved. Unless otherwise specified, no part of this publication may be reproduced or utilized in any form or by any means, electronic or mechanical, including photocopying and microfilm, without permission in writing from either ISO at the address below or ISO's member body in the country of the requester.

ISO copyright office  
Case postale 56 • CH-1211 Geneva 20  
Tel. + 41 22 749 01 11  
Fax + 41 22 749 09 47  
E-mail [copyright@iso.org](mailto:copyright@iso.org)  
Web [www.iso.org](http://www.iso.org)

Published in Switzerland

# Contents

Page

Foreword.....	iv
<b>1 Scope .....</b>	<b>1</b>
<b>2 Normative references .....</b>	<b>1</b>
<b>3 Terms and definitions.....</b>	<b>2</b>
<b>4 Quality assurance .....</b>	<b>3</b>
<b>4.1 General.....</b>	<b>3</b>
<b>4.2 Qualification inspection conditions.....</b>	<b>4</b>
<b>4.3 Acceptance inspection conditions .....</b>	<b>4</b>
<b>4.4 Use of “statistical process control (SPC)” .....</b>	<b>4</b>
<b>5 Requirements .....</b>	<b>5</b>
<b>Annex A (informative) Cross-sectional areas and formulae for tensile, tension fatigue and stress durability loads .....</b>	<b>21</b>
<b>Annex B (informative) Cross-sectional areas and formulae for double shear loads .....</b>	<b>23</b>

.....

## Foreword

ISO (the International Organization for Standardization) is a worldwide federation of national standards bodies (ISO member bodies). The work of preparing International Standards is normally carried out through ISO technical committees. Each member body interested in a subject for which a technical committee has been established has the right to be represented on that committee. International organizations, governmental and non-governmental, in liaison with ISO, also take part in the work. ISO collaborates closely with the International Electrotechnical Commission (IEC) on all matters of electrotechnical standardization.

International Standards are drafted in accordance with the rules given in the ISO/IEC Directives, Part 2.

The main task of technical committees is to prepare International Standards. Draft International Standards adopted by the technical committees are circulated to the member bodies for voting. Publication as an International Standard requires approval by at least 75 % of the member bodies casting a vote.

Attention is drawn to the possibility that some of the elements of this document may be the subject of patent rights. ISO shall not be held responsible for identifying any or all such patent rights.

ISO 5857 was prepared by Technical Committee ISO/TC 20, *Aircraft and space vehicles*, Subcommittee SC 4, *Aerospace fastener systems*.

This second edition cancels and replaces the first edition (ISO 5857:1988) which has been technically revised.

# Aerospace — Bolts, with MJ threads, made of alloy steel, strength class 1 250 MPa — Procurement specification

## 1 Scope

This International Standard specifies the characteristics and quality assurance requirements for MJ thread bolts made of alloy steel, of strength class 1 250 MPa, for aerospace construction.

It is applicable whenever it is referenced in a definition document.

## 2 Normative references

The following referenced documents are indispensable for the application of this document. For dated references, only the edition cited applies. For undated references, the latest edition of the referenced document (including any amendments) applies.

ISO 2859-1:1999, *Sampling procedures for inspection by attributes — Part 1: Sampling schemes indexed by acceptance quality limit (AQL) for lot-by-lot inspection*

ISO 4288, *Geometrical Product Specifications (GPS) — Surface texture: Profile method — Rules and procedures for the assessment of surface texture*

ISO 5855-2, *Aerospace — MJ threads — Part 2: Limit dimensions for bolts and nuts*

ISO 6507-1, *Metallic materials — Vickers hardness test — Part 1: Test method*

ISO 6508-1, *Metallic materials — Rockwell hardness test — Part 1: Test method (scales A, B, C, D, E, F, G, H, K, N, T)*

ISO 6892, *Metallic materials — Tensile testing at ambient temperature*

ISO 7870-1, *Control charts — Part 1: General guidelines*

ISO 7961, *Aerospace — Bolts — Test methods*

ISO 7966, *Acceptance control charts*

ISO 8258, *Shewhart control charts*

ISO/TR 13425, *Guidelines for the selection of statistical methods in standardization and specification*

### 3 Terms and definitions

For the purposes of this document, the following terms and definitions apply.

**3.1  
production batch**  
quantity of finished bolts, manufactured using the same process, from a single material cast (single heat of alloy), having the same definition document number, the same thread and diameter code, heat-treated together to the same specified condition and produced as one continuous run

**3.2  
inspection lot**  
quantity of bolts from a single production batch having the same definition document number

**3.3  
definition document**  
document specifying directly or indirectly all the requirements for bolts

NOTE The definition document may be an International Standard, an in-house standard or a drawing.

**3.4  
crack**  
rupture in the material which may extend in any direction and which may be intercrystalline or transcrystalline in character

**3.5  
seam**  
open surface defect

**3.6  
lap**  
surface defect caused by folding over metal fins or sharp corners and then rolling or forging them into the surface

**3.7  
crevice**  
hollow area at thread crest

**3.8  
inclusions**  
non-metallic particles originating from the material manufacturing process

NOTE These particles can be isolated or arranged in strings.

**3.9  
sampling plan**  
plan according to which one or more samples are taken in order to obtain information and possibly reach a decision

NOTE In this International Standard, each sampling plan specifies the number of bolts to be inspected as a function of the size of the batch and the acceptance number [number of defective items acceptable ( $Ac$ )<sup>1)</sup>].

**3.10  
simple random sampling**  
sampling of  $n$  items from a population of  $N$  items in such a way that all possible combinations of  $n$  items have the same probability of being chosen

---

1)  $Ac$  = acceptance number (supplementary information taken from ISO 2859-1).

**3.11****critical defect**

defect that, according to judgement and experience, is likely to result in hazardous or unsafe conditions for individuals using, maintaining or depending upon the considered product (bolt), or that is likely to prevent performance of the function of a major end item

**3.12****major defect**

defect, other than critical, that is likely to result in failure or to reduce materially the usability of the considered product (bolt) for its intended purpose

**3.13****minor defect**

defect that is not likely to materially reduce the usability of the considered product (bolt) for its intended purpose, or that constitutes a departure from the established specification, having little bearing on the effective use or operation of this product

**3.14****limiting quality****LQ**

〈sampling plan〉 quality limit which corresponds to a specified and relatively low probability of acceptance

NOTE 1 It is the limiting lot quality characteristic that the consumer is willing to accept with a low probability that a lot of this quality would occur.

NOTE 2 For the purposes of this International Standard, the limiting quality quoted in Table 4 corresponds to a probability of acceptance of 10 %.

**3.15****acceptable quality limit****AQL**

maximum percent defective (or maximum number of defects per hundred units) that, for purposes of sampling inspection, can be considered satisfactory as a process average

NOTE Variant: quality limit which, in a sampling plan, corresponds to a specified but relatively high probability of acceptance.

**4 Quality assurance****4.1 General**

The manufacturer shall be capable of providing a continuous production of bolts complying with the quality requirements specified in this International Standard. It is recommended that the manufacturer be certified to a recognized quality management system. The certification authority may be the prime contractor.

The purpose of qualification inspections<sup>2)</sup> of bolts is to check that the design and manufacturing conditions of a bolt allow it to satisfy the requirements of this International Standard.

Quality documentation for parts produced in accordance with this International Standard shall be maintained for a minimum period of 10 years.

Qualification of the bolts shall be granted by the Certification Authorities in the purchaser's country, or their appointed representative, who may be the prime contractor.

---

2) In order to simplify the text, the term "inspections" used in this International Standard also refers to "inspections and tests".

The purpose of a production acceptance inspection of a bolt is to check, as simply as possible, using a method which is inexpensive but representative of the actual conditions of use, with the uncertainty inherent in statistical sampling, that the bolt satisfies the requirements of this International Standard.

Production acceptance inspections shall be carried out by the manufacturer or under his responsibility.

#### 4.2 Qualification inspection conditions

Unless otherwise specified, the inspection shall be carried out on:

- each type and diameter of bolt;
- 25 bolts selected from a single inspection lot by simple random sampling.

The test programme may possibly be reduced, or the qualification granted, without inspection: any such decision shall be based on the results obtained on similar types and diameters of bolts provided that the design and manufacturing conditions are identical.

The inspections shall be repeated on any bolt if the manufacturing conditions have been modified.

Table 2 indicates the allocation of bolt samples for the inspections.

#### 4.3 Acceptance inspection conditions

Inspections shall be carried out on each production batch or inspection lot. Bolts from the batch or lot to be inspected shall be selected by simple random sampling.

Each bolt may be submitted to several inspections, provided that none of characteristics to be verified has been previously altered during any of these inspections.

The bolts to be subjected to destructive inspections may be those on which non-destructive inspections have been carried out.

If a more stringent inspection is deemed necessary, all or part of the qualification inspections may be performed during the acceptance inspections. In this case, the number of bolts submitted is the same as that submitted for the qualification inspection.

Production batches or inspection lots declared unacceptable after the production acceptance inspections shall be submitted for re-inspection only after all the defective units have been removed and/or defects have been corrected. In this case, the attribute(s) that caused the rejection shall be verified using a sample of twice the normal size with the same number of defective items acceptable.

#### 4.4 Use of “statistical process control (SPC)”

When a characteristic is obtained by a controlled statistical process, the manufacturer has the option, in order to declare conformity of the characteristic, to forgo the final systematic sampling provided in this International Standard, if he is capable of **formally justifying** this choice by using ISO/TR 13425 and the standards quoted in it as a basis.

This justification will include the following phases:

- analysis of the key characteristics of the product;
- analysis of the risks for each implemented process;
- determination of the parameters and/or characteristics to be respected under SPC;
- determination of the capabilities of each process;



- drawing up of an inspection plan and integration in the manufacturing process;
- drawing up of routes and control charts (ISO 7966, ISO 7870-1, ISO 8258);
- use of control charts for data consolidation;
- determination of the audits to be run and the control to be carried out to ensure reliability of the device.

To be usable in production, this process shall be validated beforehand by the qualifying body, either during the qualification phase, or *a posteriori* according to the case, by analysing the justificatory file and the results of the qualification inspections such as provided in Clause 5. **Such an SPC process is not applicable to destructive tests** apart from the stress durability test.

## 5 Requirements

The requirements of this International Standard are given in Table 1 and, unless otherwise specified, they apply to bolts that are ready for use. The test temperature, unless otherwise specified, shall be the ambient temperature. These requirements complement the requirements of all other standards or specifications referenced in the definition document.

**Table 1 — Requirements and test methods**

Subclause	Characteristic	Requirement	Inspection and test method	Designation <sup>a</sup>	Sample size
5.1	Material	In accordance with the definition document	See material standard.		As required by semi-finished product
5.2	Dimensions	In accordance with the definition document	Standard gauging	Q	20
				A	Tables 3 and 4
5.3	Manufacturing				
5.3.1	Forging	The heads of the bolts shall be formed by a hot or cold forging process before heat treatment.	According to the manufacturing route	Q	
		In the case of hot forging, the equipment shall ensure an adequate and uniform temperature throughout the production batch.	The equipment used shall be approved.		
5.3.2	Heat treatment	The forged blanks shall be heat-treated to produce the properties required by the definition document. Blanks shall not be heat-treated more than twice.	According to the process route The equipment used shall be approved.	Q	
5.3.3	Removal of surface contamination (bearing face and shank)	If machining is required, it is necessary to respect the requirements of 5.5.1.			
5.3.4	Stress-relieving	After grinding, but before thread and fillet rolling, bolts shall be stress-relieved at a temperature higher than 190 °C and (20 to 30) °C below the final tempering temperature for at least 2 h.			

Table 1 (continued)

Subclause	Characteristic	Requirement	Inspection and test method	Designation <sup>a</sup>	Sample size
5.3.5	Fillet between head and shank	<p>The fillet radius shall be cold-rolled after heat treatment and machining so as to remove all visual signs of machining and to create superficial cold working.</p> <p>The deformation shall not exceed the values given in Figure 1.</p> <p>The requirements apply to bolts except the following:</p> <p>a) bolts threaded to head;</p> <p>b) bolts with a nominal diameter &lt; 5 mm.</p>	Visual examination at a suitable magnification of 10× to 20× and dimensional check	Q	5
				A	Tables 3 and 4
5.3.6	Threads	Formed by a single rolling process after full heat treatment	According to the manufacturing route	Q	
5.3.7	Surface roughness	In accordance with the definition document	ISO 4288 Visual examination	Q	5
				A	Tables 3 and 4
5.3.8	Surface coating	In accordance with the definition document	See surface coating standard.	Q	5
				A	Tables 3 and 4
5.4	Mechanical properties				
5.4.1	Tensile strength	See Table 5.	On bolts: ISO 7961	Q	5
		<p>The requirements apply to bolts except the following:</p> <p>a) protruding head bolts of grip length &lt; twice the nominal shank diameter;</p> <p>b) countersunk head bolts of grip length &lt; two and a half times the nominal shank diameter;</p> <p>c) bolts threaded to head of overall length &lt; three times the nominal thread diameter or bolts having an overall length &lt; 18 mm;</p> <p>d) bolts with a thread length &lt; one and a half times the thread nominal diameter;</p> <p>e) bolts with a nominal diameter &lt; 4 mm.</p>	<p>On test specimen (when tests do not apply to bolts as indicated in "Requirement" column): ISO 6892</p> <p>The test specimens are to be produced from the same material batch as the bolts and treated with them.</p>	A for bolts, not for specimens	Table 6 or Table 7
5.4.2	Double shear strength	See Table 5.	ISO 7961	Q	5
		<p>The requirements apply to bolts except the following:</p> <p>a) protruding head bolts of grip length &lt; twice the nominal shank diameter;</p> <p>b) countersunk head bolts of grip length &lt; two and a half times the nominal shank diameter;</p> <p>c) bolts with a nominal diameter &lt; 4 mm;</p> <p>d) bolts threaded to head.</p>		A	Table 6 or Table 7

Table 1 (continued)

Subclause		Characteristic	Requirement	Inspection and test method	Designation <sup>a</sup>	Sample size
5.4.3	Tension fatigue strength	<p>Life:</p> <ul style="list-style-type: none"> <li>— mean value: 65 000 cycles min.</li> <li>— individual value: 45 000 cycles min. 130 000 cycles max.</li> </ul> <p>Frequency: 140 Hz max.</p> <p>Loads: see Table 8.</p> <p>The requirements apply to bolts except the following:</p> <ul style="list-style-type: none"> <li>a) protruding head bolts of grip length &lt; twice the nominal shank diameter;</li> <li>b) countersunk head bolts of grip length &lt; two and a half times the nominal shank diameter;</li> <li>c) bolts with a nominal diameter &lt; 5 mm;</li> <li>d) bolts drilled shank;</li> <li>e) bolts threaded to head.</li> </ul>	ISO 7961	Q	5	
				A	Table 6	
5.4.4	Hardness	<p>Before surface coating is applied, the hardness, when measured at the end of the bolt (thread end), shall be:</p> <ul style="list-style-type: none"> <li>— Rockwell: (39 to 43) HRC;</li> <li>— Vickers: (380 to 430) HV 30.</li> </ul>	ISO 6507-1 ISO 6508-1	Q	5	
				A	Tables 3 and 4	
5.4.5	Stress durability	<p>Loads: see Table 5.</p> <p>Time: 23 h</p> <p>SPC techniques may be used as an alternative.</p> <p>NOTE Each production batch by diameter to be tested on protruding head bolts only (grip lengths <math>\geq</math> twice the nominal shank diameter).</p>	ISO 7961	Q	3	
				A	Table 6	
5.4.6	Recess removal torque	<p>The recess of the finished bolt shall withstand the torque values specified in the product standard or definition document.</p> <p>During the test, the driving feature shall show no camout and the recess no excessive distortion.</p>	With the bolt fixed in rotation, submit the driving feature to the specified end load, while applying the required removal torque.	Q	5	

Table 1 (continued)

Subclause	Characteristic	Requirement	Inspection and test method	Designation <sup>a</sup>	Sample size
5.5	Metallurgical properties				
5.5.1	Head-to-shank grain flow	Flow lines shall closely conform to the contour indicated in Figure 2. For breaks in flow lines, see Figure 2. If there is doubt about the acceptability, it shall be decided by the results of the acceptance tension fatigue test, see 5.4.3. This test shall thus be carried out on exempted bolt types.	Macroscopic examination at a magnification of 10× to 20× (see Figure 3), after appropriate etching	Q	5
				A	Table 6
5.5.2	Thread grain flow	Shall be continuous and shall follow the general thread contour with the maximum density at the bottom of the root radius (see Figure 4).	See 5.5.1.	Q	5
				A	Table 6
5.5.3	Microstructure and overheating	Shall not: — have microporosity or major segregation; — show evidence of overheating, decarburization, carburization, nitrogenization or intergranular oxidation in excess of the limits specified in Table 9.  Overheating of the head, except for the bearing surface, is permitted provided that its maximum depth, measured normal to the surface of the head, does not exceed: — 1,5 mm for diameters ≤ 16 mm; — 2,8 mm for diameters > 16 mm.	Microscopic examination at a magnification of 100× (see Figure 3), after appropriate etching	Q	5
				A	Table 6
5.5.4	Discontinuity	See Table 9. Care shall be exercised to avoid confusing cracks with other discontinuities.	Magnetic inspection by both longitudinal and circular method.  In case of doubt, submit suspect bolts to a microscopic examination at a magnification of 100× (see Figure 3), after appropriate etching.	Q	5
				A	Table 6
5.5.5	Grinding burns	Prior to coating, there shall be no evidence of grinding burns.	ISO 7961	Q	3
5.6	Marking	In accordance with the definition document	Visual inspection	Q	25
				A	Tables 3 and 4

Table 1 (continued)

Subclause	Characteristic	Requirement	Inspection and test method	Designation <sup>a</sup>	Sample size
5.7	Delivery				
5.7.1	Packaging	To prevent all damage or corrosion occurring in the course of handling, transportation and storage  Each basic package shall only contain bolts from the same inspection lot number.	Visual inspection	A	100 %
5.7.2	Labelling	Each basic package shall carry a label which legibly indicates: — the designation as specified by the definition document; — the quantity; — the inspection lot number; — the inspector's stamp.	Visual inspection	A	100 %
5.7.3	Certificate of conformity	At the demand of the customer, each delivery shall be accompanied by a certificate of conformity certifying that, without exception or dispensation, the bolts satisfy the requirements of this International Standard.	Visual examination	A	100 %
<sup>a</sup> Q = Qualification, A = Acceptance					

Table 2 — Summary of inspections for qualification and allocation of bolt samples

Characteristic	Defined in	Bolt sample number																								
		1	2	3	4	5	6	7	8	9	10	11	12	13	14	15	16	17	18	19	20	21	22	23	24	25
<b>Non-destructive</b>																										
Dimensions	5.2						X	X	X	X	X	X	X	X	X	X	X	X	X	X	X	X	X	X	X	X
Fillet between head and shank	5.3.5 <sup>a</sup>	X	X	X	X	X																				
Surface roughness	5.3.7 <sup>a</sup>	X	X	X	X	X																				
Surface coating	5.3.8						X	X	X	X	X															
Recess removal torque	5.4.6																						X	X	X	X
Discontinuities	5.5.4 <sup>a</sup>	X	X	X	X	X																				
Marking	5.6	X	X	X	X	X	X	X	X	X	X	X	X	X	X	X	X	X	X	X	X	X	X	X	X	X
<b>Destructive</b>																										
Tensile strength	5.4.1						X	X	X	X	X															
Double shear strength	5.4.2											X	X	X	X	X										
Tension fatigue strength	5.4.3																X	X	X	X	X					
Hardness	5.4.4 <sup>a</sup>	X	X	X	X	X																				
Stress durability	5.4.5																						X	X	X	
Head-to-shank grain flow	5.5.1	X	X	X	X	X																				
Thread grain flow	5.5.2	X	X	X	X	X																				
Microstructure and overheating	5.5.3	X	X	X	X	X																				
Grinding burns	5.5.5	X	X	X																						

<sup>a</sup> Tests to be carried out prior to coating.

Table 3 — Classification of defects

Category of defects	Acceptable quality level (AQL)	Characteristics
Major	0,065 %	Discontinuities
	1 %	Thread size Shank diameter Grip length Fillet radius: distortion and dimensions Drilled hole(s) missing when required Surface roughness Burrs and tool marks Surface coating Marking Depth of lightening hole Thread form Incomplete threads Head angle (countersunk head) Perpendicularity of head-bearing surface Straightness of shank
Minor	2,5 %	Overall length Head diameter Lightening hole diameter Drilled hole(s) position tolerance and diameter Wrenching configuration Run-out — Head external diameter to shank Run-out — Thread pitch diameter to shank Recess torque
	4 %	Chamfer of thread end Hexagon head: chamfer and washer face Collar height Head height

Table 4 — Sampling plans for visual inspections and dimensional characteristics

Production batch size	Sample size	Acceptance number (Ac) and limiting quality (LQ) in accordance with the acceptable quality limit (AQL)									
		AQL 0,065 %		AQL 1 %		AQL 2,5 %		AQL 4 %			
		Ac	LQ <sub>10</sub> %	Ac	LQ <sub>10</sub> %	Ac	LQ <sub>10</sub> %	Ac	LQ <sub>10</sub> %		
2 to 8	2	↓	↓	↓	↓	↓	↓	↓	↓	↓	↓
9 to 15	3	↓	↓	↓	↓	↓	↓	0	↓	0	53,6
16 to 25	5	↓	↓	↓	↓	0	↓	36,9	↑	↑	↑
26 to 50	8	↓	↓	↓	↓	↓	↑	↑	↓	↓	↓
51 to 90	13	↓	↓	0	16,2	↑	↓	1	↓	1	26,8
91 to 150	20	↓	↓	↑	↑	1	18,1	2	↓	2	24,5
151 to 280	32	↓	↓	↓	↓	2	15,8	3	↓	3	19,7
281 to 500	50	↓	↓	1	7,56	3	12,9	5	↓	5	17,8
501 to 1 200	80	↓	↓	2	6,52	5	11,3	7	↓	7	14,3
1 201 to 3 200	125	↓	↓	3	5,27	7	9,24	10	↓	10	12,1
3 201 to 10 000	200	0	1,14	5	4,59	10	7,60	14	↓	14	9,81
10 001 to 35 000	315	↑	↑	7	3,71	14	6,33	21	↓	21	8,84
35 001 to 150 000	500	↓	↓	10	3,06	21	5,60	↑	↓	↑	↑
150 001 to 500 000	800	1	0,485	14	2,51	↑	↑	↑	↓	↑	↑

↑ Use sampling plan above (sample size and Ac).

↓ Use sampling plan below (sample size and Ac).

The data given in this table are based on single sampling plans for a normal inspection, as specified in ISO 2859-1:1999, Tables 2-A and 6-A. A 100 % inspection should be performed when the sample size is equal to or greater than the batch size.

Other sampling plans specified in ISO 2859-1 may be used (double or multiple sampling), but these shall be chosen in such a way as to ensure an equivalent quality limit.

For those manufacturers who carry out an inspection during the manufacturing process (inspection on a machine and/or inspection between operations), the sampling plan for the final inspection shall be compiled in such a way that the overall inspection plan shall guarantee an equivalent quality limit.



Table 5 — Minimum loads for tensile <sup>a</sup>, double shear <sup>b</sup> and stress durability <sup>a</sup> tests

Thread		Tensile strength test				Double shear strength test	Stress durability test for protruding head <sup>c</sup>
Diameter	Pitch	Protruding head	Countersunk head				
			Normal head	Reduced head			
mm	mm	kN	kN	no recess kN	recessed kN	kN	kN
4	0,7	11,9	9,52	5,95	5,36	18,9	8,93
5	0,8	19,1	15,3	9,56	8,6	29,5	14,3
6	1	27,2	21,8	13,6	12,2	42,4	20,4
7		38,7	30,9	19,3	15,5	57,7	29
8		52,1	41,7	26,1	20,8	75,4	39,1
10	1,25	81,4	65,1	40,7	32,6	118	61,1
12		121	96,8	60,5	48,4	170	90,8
14	1,5	165	132	82	66	231	124
16		220	176	110	70,4	302	165
18		282	226	142	90,2	382	212
20		353	282	176	113	471	265
22		432	346	216	138	570	324
24	2	502	402	251	161	678	377

<sup>a</sup> See Annex A for areas and formulae.

<sup>b</sup> See Annex B for areas and formulae.

<sup>c</sup> For countersunk head bolts, apply to these values the parameter *k* values in A.2.2.

Table 6 — Sampling plans for the inspection of mechanical and metallurgical characteristics

Production batch size	Sample size destructive testing	Acceptance number (Ac)
≤ 500	3	0
501 to 3 200	5	0
3 201 to 35 000	5	0
≥ 35 001	8	0

Table 7 — Variable sampling for tensile and shear tests

Production batch size	Sample number	Acceptable quality limit approximately AQL 1 %				
		Sample size	Total	First sample		Combined sample
				$K_a$	$K_r$	
≤ 150	First	4	4	2,42	1,35	—
	Second	8	12	—	—	1,72
151 to 280	First	5	5	2,21	0,89	—
	Second	10	15	—	—	1,74
281 to 500	First	6	6	2,22	0,94	—
	Second	12	18	—	—	1,7
501 to 1 200	First	7	7	2,32	1,1	—
	Second	14	21	—	—	1,78
1 201 to 3 200	First	8	8	2,48	0,99	—
	Second	16	24	—	—	1,81
≥ 3 201	First	10	10	2,34	1,31	—
	Second	20	30	—	—	1,8

Evaluate each sample by tensile or shear tests as follows:

First sample: accept if  $\bar{X}_1 - K_a S_1 \geq M$                                   Reject if  $\bar{X}_1 - K_r S_1 < M$

Take a second sample if batch is doubtful; evaluate as follows:

Second sample: accept if  $\bar{X}_1 - K_t S_t \geq M$                                   Reject if  $\bar{X}_1 - K_t S_t < M$

Definition of symbols:

- $\bar{X}_1$  is the average of  $X_1$  individual values in the first sample;
- $K_a$ ,  $K_r$  and  $K_t$  are coefficients of  $S$ , which is the best estimate of standard deviation, and are used to determine acceptance or rejection of the batch represented by the sample;
- $M$  is the minimum tensile or the minimum shear value according to Table 5;
- $\bar{X}_t$  is the average of  $X_t$  individual values in the combined samples;

$$S_1 = \sqrt{\frac{N_1 \sum X_1^2 - (\sum X_1)^2}{N_1 (N_1 - 1)}}$$

where

- $N_1$  is the sample size of the first sample;
- $\sum X_1^2$  is the sum of squares of  $X_1$  values;
- $(\sum X_1)^2$  is the square of the sum of  $X_1$  values;

$$S_t = \sqrt{\frac{N_t \sum X_t^2 - (\sum X_t)^2}{N_t (N_t - 1)}}$$

where

- $N_t$  is the sample size of the combined sample;
- $\sum X_t^2$  is the sum of squares of  $X_t$  values;
- $(\sum X_t)^2$  is the square of the sum of  $X_t$  values.

Table 8 — Tension fatigue test loads <sup>a</sup>

Thread		Protruding head		Countersunk head					
Diameter mm	Pitch mm			Normal head		Reduced head			
		High load ± 2 % kN	Low load ± 2 % kN	High load ± 2 % kN	Low load ± 2 % kN	no recess		recessed	
						High load ± 2 % kN	Low load ± 2 % kN	High load ± 2 % kN	Low load ± 2 % kN
5	0,8	8,8	0,88	5,81	0,58	4,4	0,44	3,96	0,4
6	1	12,5	1,25	8,27	0,83	6,25	0,63	5,63	0,56
7		17,8	1,78	14,2	1,42	8,89	0,89	7,12	0,71
8		24	2,4	19,2	1,92	12	1,2	9,59	0,96
10	1,25	37,4	3,74	30	3	18,7	1,87	15	1,5
12		55,7	5,57	44,5	4,45	27,8	2,78	22,3	2,23
14	1,5	75,9	7,59	60,7	6,07	38	3,8	30,4	3,04
16		101	10,1	81	8,1	50,6	5,06	32,4	3,24
18		130	13	104	10,4	64,9	6,49	41,5	4,15
20		162	16,2	130	13	81,2	8,12	52	5,2
22		199	19,9	159	15,9	99,4	9,94	63,6	6,36
24	2	231	23,1	185	18,5	115	11,5	73,9	7,39

<sup>a</sup> See Annex A for areas and formulae.

Table 9 — Discontinuities and decarburization

Type	Location	Maximum depth, normal to surface mm		
		Bolts threaded to head (all diameters) and other bolts $D < 5$ mm	Bolts $5 \text{ mm} \leq D \leq 16 \text{ mm}$	Bolts $D > 16 \text{ mm}$
Cracks	All zones	0	0	0
Laps, seams, inclusions	Head-to-shank fillet	0	0	0
	Root of thread <sup>a</sup>	0	0	0
	Non-bearing surface of head	0,3	0,25	0,3
Seams	Shank and bearing face	0,15	0,12	0,15
Laps and seams, forming an angle of more than 10° with the longitudinal axis	Shank	0,1	0	0
Laps	Unload flank of threads	See Table 10 and Figures 5 and 6.		
Laps and/or crevices	Crest of thread <sup>b</sup>	See Table 10 and Figures 6 and 8. NOTE Values increased by half the difference between the actual measured diameter and the minimum external diameter (see ISO 5855-2).		
Decarburization	Non-bearing surface of head			
	partial	0,1	0,1	0,1
	total	0	0	0
	All zones except on head-to-shank fillet, root of thread, shank and bearing face and non-bearing surface of head			
	partial	0,2	0,1	0,2
	total	0	0	0
<sup>a</sup> See Figure 5. <sup>b</sup> See Figure 7.				

Table 10 — Thread discontinuities <sup>a</sup>

Dimensions in millimetres

Thread pitch	Maximum depth
0,7	0,08
0,8	0,09
1	0,12
1,25	0,15
1,5	0,18
2	0,24
<sup>a</sup> Nature and position (see Table 9).	

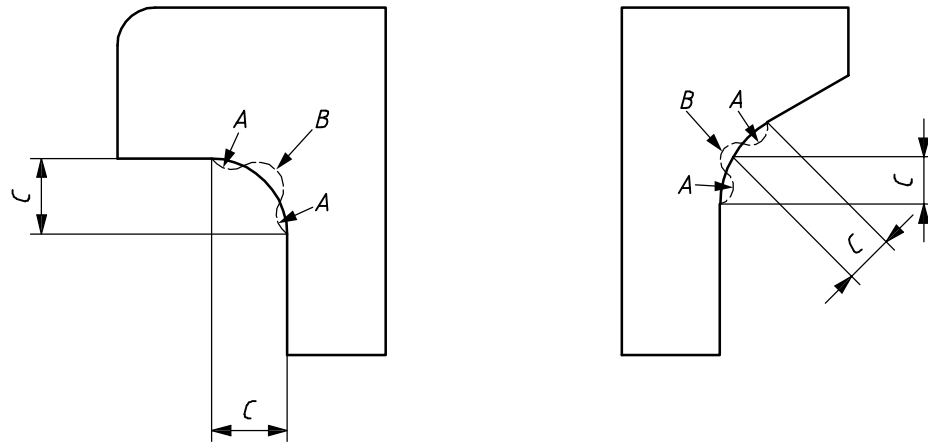

Dimensions in millimetres

Bolt nominal diameter	A max.	B max.	C max.
5	0,03	0,025	1,5
6			
7			
8			2,5
10			
12			3,5
14			
16			4,5
18			
20			
22			
24			

Figure 1 — Distortion in head-to-shank fillet area (see 5.3.5)

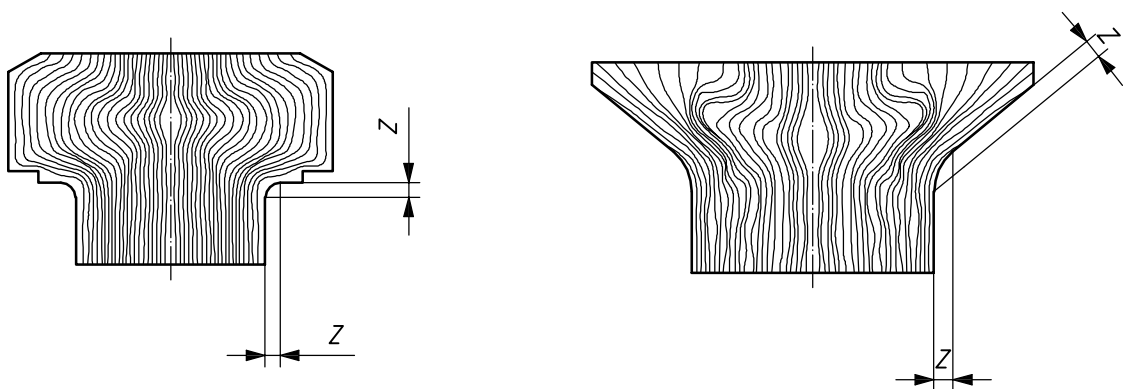

NOTE Cut grain acceptable in the zone identified by  $Z$  dimensions (where  $R$  max. is the maximum fillet radius specified in the definition document).

Figure 2 — Head-to-shank grain flow (see 5.5.1)

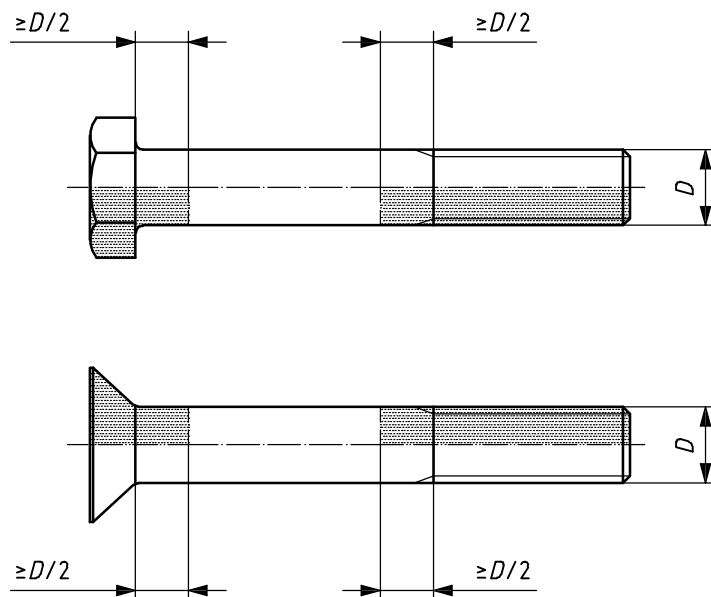

Cut here for test pieces to be subjected to micro- or macroscopic examination.

**Figure 3 — Metallurgical test pieces** (see 5.5.1 to 5.5.4)

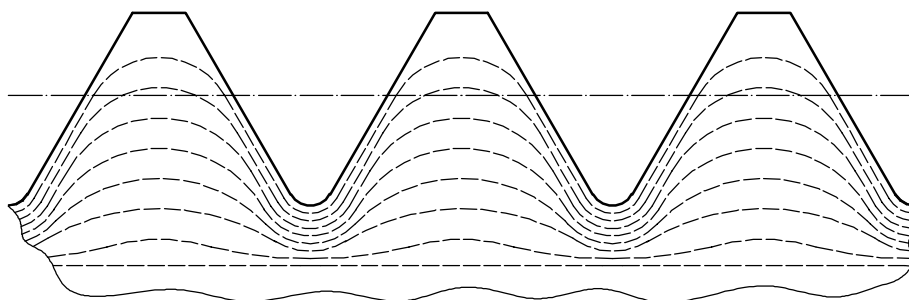

**Figure 4 — Grain flow in threads** (see 5.5.2)

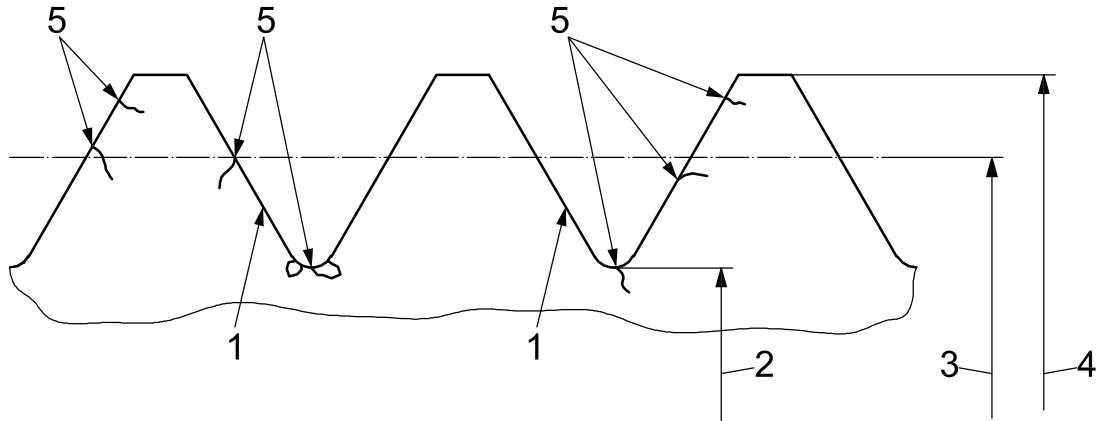

**Key**

- 1 non-loaded flanks
- 2 minor diameter
- 3 pitch diameter
- 4 major diameter
- 5 non-permissible laps and seams

**Figure 5 — Non-permissible laps, seams and surface irregularities in threads**

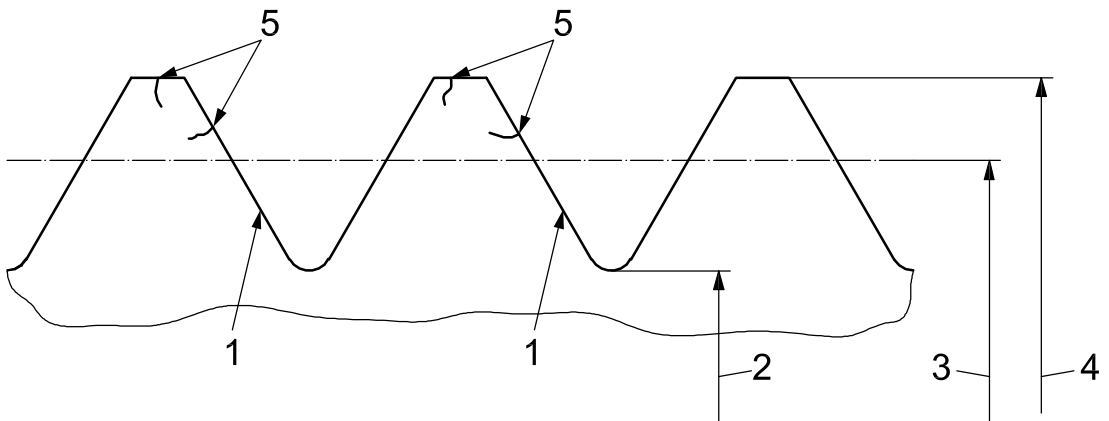

**Key**

- 1 non-loaded flanks
- 2 minor diameter
- 3 pitch diameter
- 4 major diameter
- 5 permissible laps and seams

**Figure 6 — Permissible laps and seams in threads**

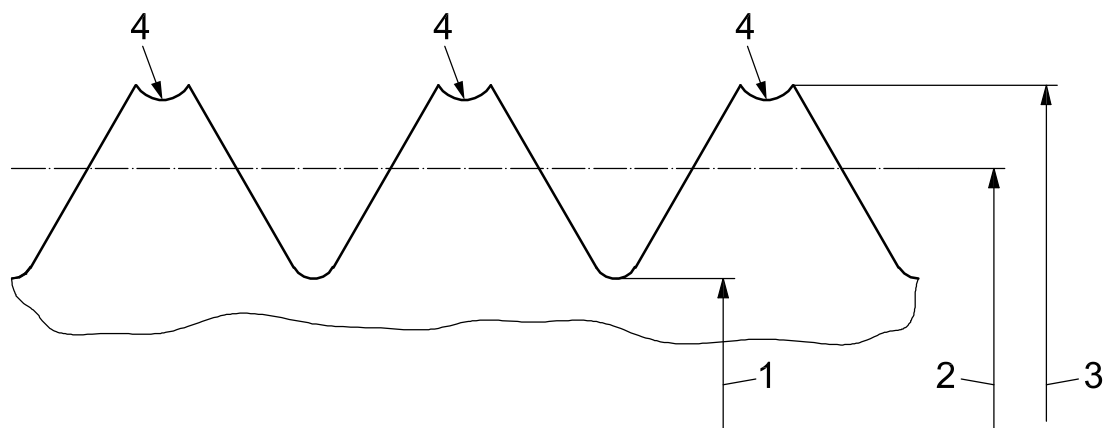

**Key**

- 1 minor diameter
- 2 pitch diameter
- 3 major diameter
- 4 permissible surface irregularities (see Table 9)

**Figure 7 — Permissible surface irregularities in threads**

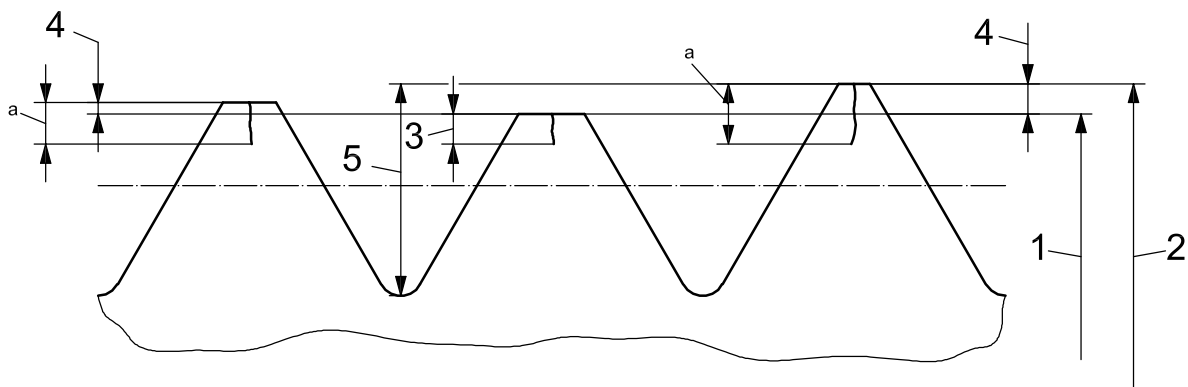

**Key**

- 1 minimum major diameter
- 2 maximum major diameter
- 3 maximum permissible discontinuity: 20 % of basic thread depth (see Table 10)
- 4 difference between actual major diameter and minimum major diameter
- 5 basic thread depth
- a See Tables 9 and 10.

**Figure 8 — Thread discontinuities**



## Annex A (informative)

### Cross-sectional areas and formulae for tensile, tension fatigue and stress durability loads

#### A.1 Cross-sectional area values

See Table A.1.

Table A.1

Thread		Cross-sectional area mm <sup>2</sup>
Diameter mm	Pitch mm	
4	0,7	9,517
5	0,8	15,296
6	1	21,753
7		30,93
8		41,682
10	1,25	65,136
12		97,128
14	1,5	131,562
16		175,613
18		225,949
20		282,571
22		345,478
24	2	401,68

#### A.2 Formulae

##### A.2.1 Cross-sectional area, $A_t$

$$A_t = \frac{\pi}{4} (d_3)^2 \left[ 2 - \left( \frac{d_3}{d_2} \right)^2 \right] \quad (\text{A.1})$$

where

$d_2$  is the maximum pitch diameter (according to ISO 5855-2), in millimetres;

$d_3$  is the maximum root diameter (according to ISO 5855-2), in millimetres.

### A.2.2 Tensile test load, $L_t$

$$L_t = \frac{A_t \times k \times R_m}{1\,000} \text{ kN} \quad (\text{A.2})$$

where

$k$	for protruding head bolts	= 1
$k$	for normal countersunk head bolts	= 0,8
$k$	for reduced countersunk head bolts without drive recess in head	= 0,5
$k$	for reduced countersunk head bolts with drive recess in head:	
—	for diameters $\leq 6$ mm	= 0,45
—	for diameters $7 \text{ mm} \leq D \leq 14$ mm	= 0,4
—	for diameters $\geq 16$ mm	= 0,32

$$R_m = 1\,250 \text{ MPa}$$

### A.2.3 Tension fatigue test load

- a) High load =  $0,46 \times$  minimum tensile strength test load, except for normal countersunk head bolts with diameters 5 mm and 6 mm where high load =  $0,38 \times$  minimum tensile strength test load.

In addition, for countersunk head bolts, apply the parameter  $k$  values in A.2.2.

- b) Low load =  $0,1 \times$  high load.

### A.2.4 Stress durability test load

Loads =  $0,75 \times$  minimum tensile strength test load.

## Annex B (informative)

### Cross-sectional areas and formulae for double shear loads

#### B.1 Cross-sectional area values (single section)

See Table B.1.

Table B.1

Nominal shank diameter mm	Cross-sectional area mm <sup>2</sup>
4	12,566
5	19,635
6	28,274
7	38,485
8	50,265
10	78,54
12	113,1
14	153,9
16	201,1
18	254,5
20	314,2
22	380,1
24	452,4

#### B.2 Formulae

##### B.2.1 Shear strength cross-sectional area, $A_s$ (single section)

$$A_s = \frac{\pi}{4} d^2 \quad (\text{B.1})$$

where  $d$  is the nominal shank diameter.

##### B.2.2 Double shear strength test load, $L_s$

$$L_s = \frac{2 A_s R_c}{1\,000} \text{ kN} \quad (\text{B.2})$$

where

$$R_c = 750 \text{ MPa}$$

---

---

**ICS 49.030.20**

Price based on 23 pages