Resistance welding — Spot welding electrode caps

*Soudage par résistance — Embouts amovibles de pointes d'électrodes
pour soudage par points*



Reference number
ISO 5821:2009(E)

© ISO 2009

PDF disclaimer

This PDF file may contain embedded typefaces. In accordance with Adobe's licensing policy, this file may be printed or viewed but shall not be edited unless the typefaces which are embedded are licensed to and installed on the computer performing the editing. In downloading this file, parties accept therein the responsibility of not infringing Adobe's licensing policy. The ISO Central Secretariat accepts no liability in this area.

Adobe is a trademark of Adobe Systems Incorporated.

Details of the software products used to create this PDF file can be found in the General Info relative to the file; the PDF-creation parameters were optimized for printing. Every care has been taken to ensure that the file is suitable for use by ISO member bodies. In the unlikely event that a problem relating to it is found, please inform the Central Secretariat at the address given below.



COPYRIGHT PROTECTED DOCUMENT

© ISO 2009

All rights reserved. Unless otherwise specified, no part of this publication may be reproduced or utilized in any form or by any means, electronic or mechanical, including photocopying and microfilm, without permission in writing from either ISO at the address below or ISO's member body in the country of the requester.

ISO copyright office
Case postale 56 • CH-1211 Geneva 20
Tel. + 41 22 749 01 11
Fax + 41 22 749 09 47
E-mail copyright@iso.org
Web www.iso.org

Published in Switzerland

Foreword

ISO (the International Organization for Standardization) is a worldwide federation of national standards bodies (ISO member bodies). The work of preparing International Standards is normally carried out through ISO technical committees. Each member body interested in a subject for which a technical committee has been established has the right to be represented on that committee. International organizations, governmental and non-governmental, in liaison with ISO, also take part in the work. ISO collaborates closely with the International Electrotechnical Commission (IEC) on all matters of electrotechnical standardization.

International Standards are drafted in accordance with the rules given in the ISO/IEC Directives, Part 2.

The main task of technical committees is to prepare International Standards. Draft International Standards adopted by the technical committees are circulated to the member bodies for voting. Publication as an International Standard requires approval by at least 75 % of the member bodies casting a vote.

Attention is drawn to the possibility that some of the elements of this document may be the subject of patent rights. ISO shall not be held responsible for identifying any or all such patent rights.

ISO 5821 was prepared by Technical Committee ISO/TC 44, *Welding and allied processes*, Subcommittee SC 6, *Resistance welding and allied mechanical joining*.

This second edition cancels and replaces the first edition (ISO 5821:1979) which has been technically revised.

Requests for official interpretations of any aspect of this International Standard should be directed to the Secretariat of ISO/TC 44/SC 6 via your national standards body, a complete listing of which can be found at www.iso.org.

Vertical line of text on the right side of the page.

Resistance welding — Spot welding electrode caps

1 Scope

This International Standard specifies the dimensions and tolerances of resistance spot welding electrode caps, where a female taper (see ISO 1089) is used to fix the cap to an electrode adaptor (see ISO 5183-1 and ISO 5183-2).

It applies only to electrode caps for which the electrode force, F_E , given for diameter d_1 in Table 2 and Table A.2 is not exceeded.

2 Normative references

The following referenced documents are indispensable for the application of this document. For dated references, only the edition cited applies. For undated references, the latest edition of the referenced document (including any amendments) applies.

ISO 1089, *Electrode taper fits for spot welding equipment — Dimensions*

ISO 5182, *Resistance welding — Materials for electrodes and ancillary equipment*

ISO 5183-1, *Resistance welding equipment — Electrode adaptors, male taper 1:10 — Part 1: Conical fixing, taper 1:10*

ISO 5183-2, *Resistance welding equipment — Electrode adaptors, male taper 1:10 — Part 2: Parallel shank fixing for end-thrust electrodes*

ISO 17677-1, *Resistance welding — Vocabulary — Part 1: Spot, projection and seam welding*

3 Terms and definitions

For the purposes of this document, the terms and definitions given in ISO 17677-1 apply.

4 Dimensions and tolerances

The dimensions shall be as given in Table 1 and Figure 1 for taper 1:10 and as given in Annex A for taper 1:9,6. ISO 1089 shall be used to provide the taper dimensions. Tolerances shall be as given in Table 3.

To enlarge the application potential of this International Standard, common variations of the base types are specified in Table 1. Preferred values are printed in bold-face.

Depending on the working stroke of the guns, two additional lengths, l_1 , are offered to allow optimized lifetimes of the caps using tip dressers.

D_2 and R_1 allow options to adapt the contact areas to different electrode indentations and nugget sizes.

The electrode force, F_E , given for diameter d_1 in Table 2 and Table A.2 should not be exceeded.

Table 1 — Dimensions for taper 1:10 (preferred values are printed in bold-face)

Linear dimensions in millimetres

Type	d_1	d_2			d_3	l_1			l_2	l_3	e	R_1			R_2	α °		
A0	13	—	—	—	10,0	18,0	21,0	24,0	8,5	—	—	30	65	100	—	—	—	—
	16	—	—	—	12,0	20,0	23,0	25,0	10,5	—	—	40	70	100	—	—	—	—
	20	—	—	—	15,0	22,0	25,0	28,0	12,0	—	—	50	75	100	—	—	—	—
B0	13	5,0	6,0	7,0	10,0	18,0	21,0	24,0	8,5	—	—	30	flat	—	—	30	45	—
	16	6,0	7,0	8,0	12,0	20,0	23,0	25,0	10,5	—	—	40	flat	50	—	30	45	—
	20	8,0	9,0	10,0	15,0	22,0	25,0	28,0	12,0	—	—	50	flat	75	—	30	45	—
C0	13	—	—	—	10,0	18,0	21,0	24,0	8,5	—	—	—	—	—	—	—	—	—
	16	—	—	—	12,0	20,0	23,0	25,0	10,5	—	—	—	—	—	—	—	—	—
	20	—	—	—	15,0	22,0	25,0	28,0	12,0	—	—	—	—	—	—	—	—	—
D0	13	5,0	—	—	10,0	18,0	21,0	24,0	8,5	—	3,0	32	flat	—	—	30	45	60
	16	6,0	—	—	12,0	20,0	23,0	25,0	10,5	—	4,0	40	flat	—	—	30	45	60
	20	8,0	—	—	15,0	22,0	25,0	28,0	12,0	—	5,0	50	flat	—	—	30	45	60
E0	13	—	—	—	10,0	18,0	21,0	24,0	8,5	8,0	—	5	—	—	—	20	—	—
	16	—	—	—	12,0	20,0	23,0	25,0	10,5	10,5	—	6	—	—	—	20	—	—
	20	—	—	—	15,0	22,0	25,0	28,0	12,0	12,0	—	8	—	—	—	20	—	—
F0	13	—	—	—	10,0	18,0	21,0	24,0	8,5	—	—	6,5	—	—	—	—	—	—
	16	—	—	—	12,0	20,0	23,0	25,0	10,5	—	—	8	—	—	—	—	—	—
	20	—	—	—	15,0	22,0	25,0	28,0	12,0	—	—	10	—	—	—	—	—	—
F1	13	5,0	5,5	6,0	10,0	18,0	21,0	24,0	8,5	6,0	—	50	63	flat	6,5	—	—	—
	16	5,5	6,5	8,0	12,0	20,0	23,0	25,0	10,5	7,5	—	50	80	flat	8,0	—	—	—
	20	6,0	7,0	8,0	15,0	22,0	25,0	28,0	12,0	9,5	—	50	100	flat	10,0	—	—	—
G0	13	5,0	—	—	10,0	18,0	21,0	24,0	8,5	10,5	—	32	—	flat	5,0	—	15°20'	—
	16	6,0	—	—	12,0	20,0	23,0	25,0	10,5	12,0	—	40	—	flat	6,0	15	17	—
	20	8,0	—	—	15,0	22,0	25,0	28,0	12,0	10,0	—	50	—	flat	8,0	22,5	20	—

NOTE For tolerances on dimensions, see Table 3.

Table 2 — Recommended maximum electrode force, F_E , depending on the hardness of the caps, given for diameter d_1 , taper 1:10

d_1 mm	Electrode force F_E Hardness \leq 150 HB	Electrode force F_E Hardness $>$ 150 HB
	kN	kN
13	2,5	3,5
16	4,0	5,5
20	6,3	7,5

Table 3 — Tolerances on dimensions

Dimension	Tolerance
d_1	$\pm 0,15$ mm
d_2	$\pm 0,2$ mm
d_3	$\begin{matrix} 0 \\ -0,1 \end{matrix}$ mm
l_1	$\pm 0,5$ mm
l_2	$\pm 0,5$ mm
l_3	$\pm 0,5$ mm
$l_1 - l_2$	—
$R_1 \leq 30$ mm	$\pm 0,5$ mm
$R_1 > 30$ mm	$\pm 2,0$ mm
R_2	$\pm 0,5$ mm
α	$\pm 1^\circ$
α_T	$\begin{matrix} 0 \\ -6' \end{matrix}$
c	$\pm 0,02$ mm
α_T	angle of taper
c	circularity

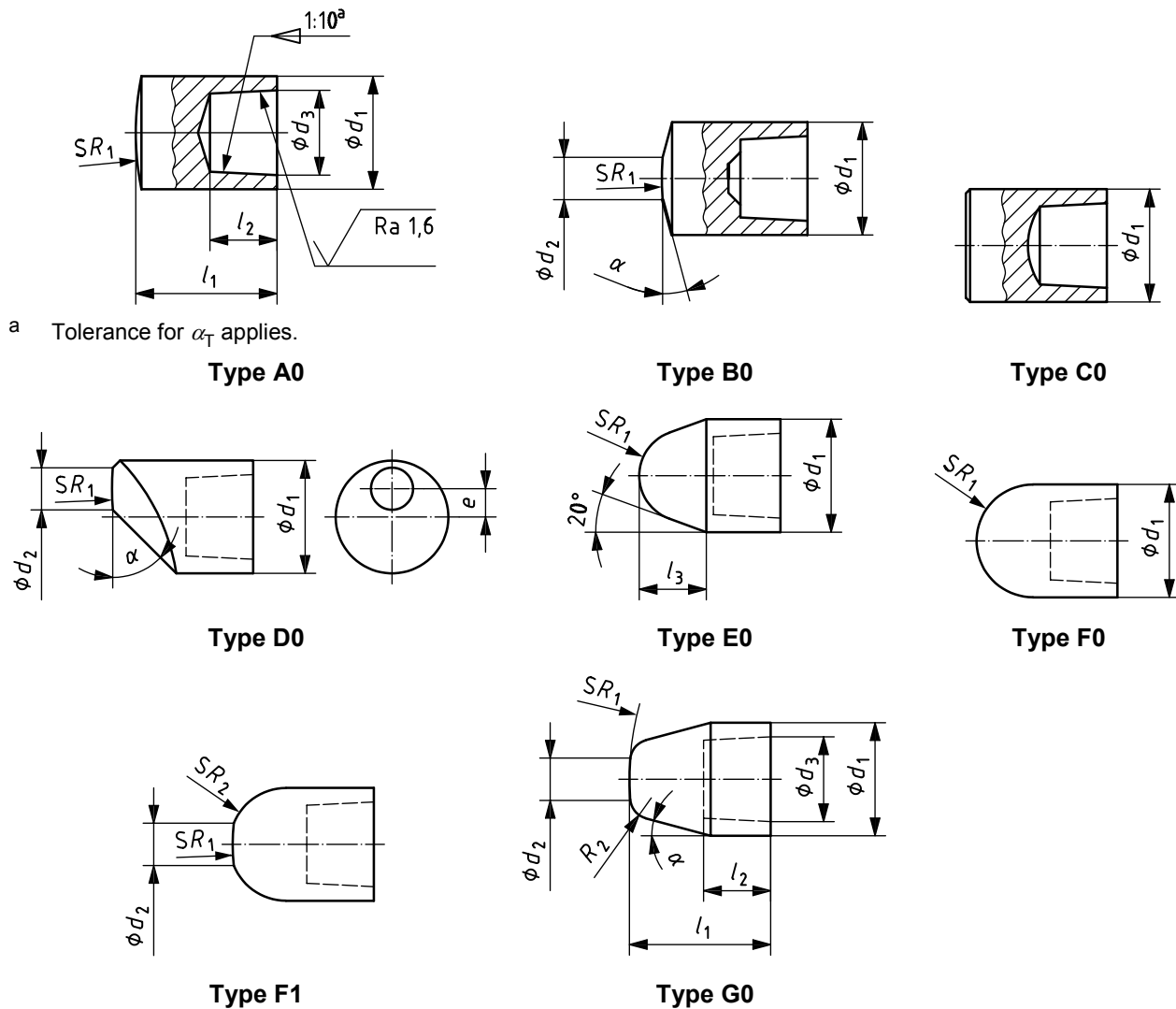

NOTE Types A0, B0, C0 and D0 denote representative forms of water hole configuration. “S” denotes spherical radiuses.

Figure 1 — Female electrode caps

5 Designation

EXAMPLES

A spot welding electrode cap type B0 (i.e. taper 1:10), width $d_1 = 16$ mm, length $l_1 = 20$ mm, $R_1 = 30$ mm, $d_2 = 8$ mm and $\alpha = 45^\circ$, is designated as follows:

Spot welding electrode cap ISO 5821 – B0 – 16 – 20 – 30 – 8 – 45

A spot welding electrode cap type A0 (i.e. taper 1:10), width $d_1 = 20$ mm, length $l_1 = 22$ mm, $R_1 = 50$ mm (d_2 and α are not applicable), is designated as follows:

Spot welding electrode cap ISO 5821 – A0 – 20 – 22 – 50

A spot welding electrode cap type C0 (i.e. taper 1:10), width $d_1 = 13$ mm, length $l_1 = 18$ mm (R_1 , d_2 and α are not applicable), is designated as follows:

Spot welding electrode cap ISO 5821 – C0 – 13 – 18

6 Material

Materials in accordance with ISO 5182 shall be used.

7 Marking

The package shall be marked with the full designation and material used, for example in accordance with the first example in Clause 5.

ISO 5821 – B0 – 16 – 20 – 30 – 8 – 45 – A2/2

Annex A (normative)

Alternative types and dimensions of female electrode caps

A.1 General

The classification according to Table 1 is mainly based on the previous edition of this International Standard. The classification according to Annex A is mainly based on standards specifying taper 1:9,6. Application of either type of classification designation identifies a product as classified according to this International Standard. Annex A has been incorporated to improve the market relevance of this International Standard, especially in countries where taper 1:9,6 is still used. Although it is recognised that the 1:10 taper is not universally used currently, it is felt that a move to a 1:10 taper would be in the interest of global relevance and therefore it is intended to delete this annex in a future revision.

A.2 Types and dimensions

Table A.1 and Figure A.1 show alternative types of female electrode caps; the corresponding symbols between Table 1 and Figure 1 and this annex are in parentheses. Tolerances shall be as given in Table 3.

Table A.1 — Alternative dimensions with taper 1:9,6

Linear dimensions in millimetres

d_1 (M)	Type	Table 1 functional equivalent	$l_1 - l_2$ (G)	d_2 (D)	(N)	R_1 (R)	α (S)	l_1 (L)	d_3 (J)	l_2 (P)
12,7	FA	G0	11,7	4,8	9,5	4,1	15°20'	21,3	10,01	9,1
	FB	F1		4,8	6,4	4,1	—			
	FC	C0		—	—	—	—			
	FD	D0		4,8	—	—	50°			
	FE	B0		4,8	—	—	45°			
	FF	A0		—	—	50,1	—			
13	FB	F1	9,5	6	—	8	—	20	10	9
15,8	FA	G0	9,4	6,4	12,7	5,6	17°	22,35	12,56	9,9
	FB	F1		6,4	9,5	5,6	—			
	FC	C0		—	—	—	—			
	FD	D0		6,4	—	—	45°			
	FE	B0		6,4	—	—	45°			
	FF	A0		—	—	50,1	—			
16	FA	G0	12,1	6	—	8	—	23	12,6	10,9
	FB	F1	11,5	6	—	8	—	23	12,6	10
19	FB	F1	8,5	8	—	8	—	25	14	15
19,1	FA	G0	9,4	7,1	19,1	7,1	20°	25,4	15,88	11,0
	FB	F1		7,1	9,5	7,1	—			
	FC	C0		—	—	—	—			
	FD	D0		7,1	—	—	45°			
	FE	B0		7,1	—	—	45°			
	FF	A0		—	—	101,6	—			
NOTE 12,7 mm = 1/2 inch; 15,8 mm = 5/8 inch; 19,1 mm = 3/4 inch.										

Table A.2 — Recommended maximum electrode force, F_E , given for diameter d_1 , taper 1:9,6

d_1 mm	Electrode force F_E Hardness \leq 150 HB	Electrode force F_E Hardness $>$ 150 HB
	kN	kN
12,7	2,6	3,6
15,8	4,9	6,8
19,1	7,6	9,1

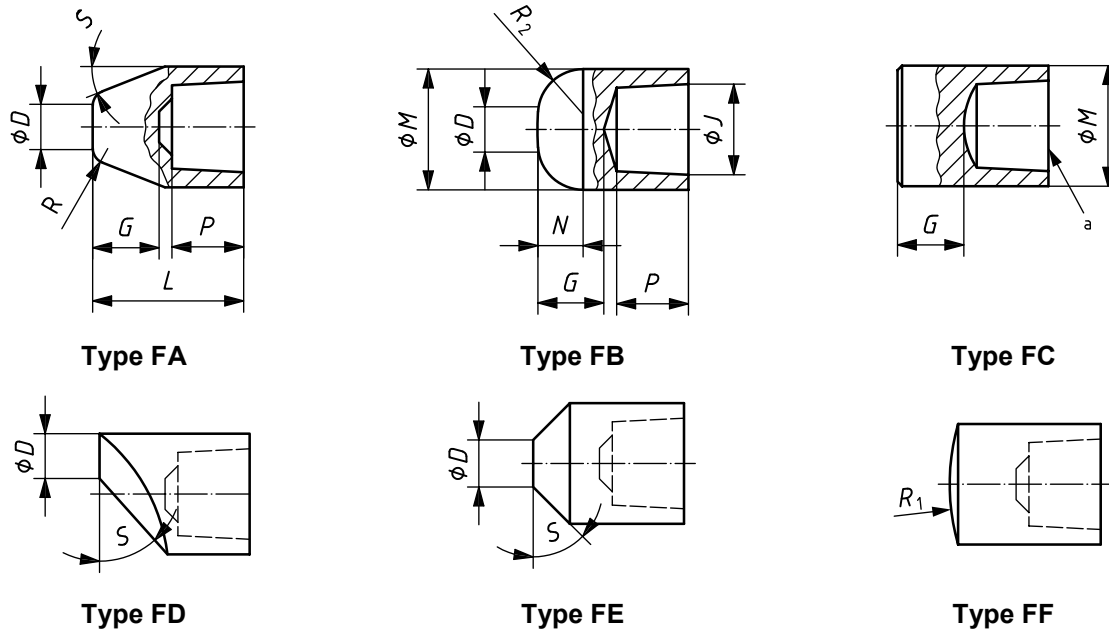

^a Taper 1:9,6.

Figure A.1 — Alternative female electrode caps

A.3 Designation

EXAMPLE

A spot welding electrode cap type FA (i.e. taper 1:9,6) in accordance with Table A.1, width $d_1 = 12,7$ mm, is designated as follows:

Spot welding electrode cap ISO 5821 – FA – 12,7

Bibliography

- [1] ISO 286-2, *ISO system of limits and fits — Part 2: Tables of standard tolerance grades and limit deviations for holes and shafts*
- [2] ISO 1119, *Geometrical Product Specifications (GPS) — Series of conical tapers and taper angles*
- [3] ISO 5822, *Spot welding equipment — Taper plug gauges and taper ring gauges*

ICS 25.160.30

Price based on 9 pages