International Standard



5807

INTERNATIONAL ORGANIZATION FOR STANDARDIZATION • МЕЖДУНАРОДНАЯ ОРГАНИЗАЦИЯ ПО СТАНДАРТИЗАЦИИ • ORGANISATION INTERNATIONALE DE NORMALISATION

Information processing — Documentation symbols and conventions for data, program and system flowcharts, program network charts and system resources charts

Traitement de l'information — Symboles de documentation et conventions applicables aux données, aux organigrammes de programmation et d'analyse, aux schémas des réseaux de programmes et des ressources de système

First edition — 1985-02-15

UDC 681.3 : 003.62/.63

Ref. No. ISO 5807-1985 (E)

Descriptors : data processing, information interchange, computer programs, symbols, graphic methods, charts, flowcharts.

Price based on 25 pages

Foreword

ISO (the International Organization for Standardization) is a worldwide federation of national standards bodies (ISO member bodies). The work of preparing International Standards is normally carried out through ISO technical committees. Each member body interested in a subject for which a technical committee has been established has the right to be represented on that committee. International organizations, governmental and non-governmental, in liaison with ISO, also take part in the work.

Draft International Standards adopted by the technical committees are circulated to the member bodies for approval before their acceptance as International Standards by the ISO Council. They are approved in accordance with ISO procedures requiring at least 75 % approval by the member bodies voting.

International Standard ISO 5807 was prepared by Technical Committee ISO/TC 97, *Information processing systems*.

Contents

	Page
0 Introduction	1
1 Scope and field of application	1
2 Reference	1
3 Definitions	1
4 Data flowchart	1
5 Program flowchart	2
6 System flowchart	2
7 Program network chart	2
8 System resources chart	2
9 Symbols	2
10 Conventions	11
11 Consolidated table of symbols	17
Annexes	
A Example of data flowchart	21
B Examples of program flowchart	22
C Example of system flowchart	24
D Example of program network chart	25
E Example of system resources chart	26

Information processing — Documentation symbols and conventions for data, program and system flowcharts, program network charts and system resources charts

0 Introduction

This International Standard consolidates the information given in ISO 1028 and ISO 2636, and in so doing, supersedes them.

Charts are widely used to depict various types of information processing problems and their means of solution. This International Standard does not restrict their use to the particular applications exemplified herein.

In-house rules may have to be devised to suit the process or data specification being considered. However, there are guiding principles which, if followed, will enhance readability and expedite cross-reference to the text.

Charts consist of symbols having a given signification, brief explanatory text, and connecting lines. This International Standard does not deal with the wording of the text. Nevertheless, each symbol relates to an unambiguous and meaningful name (unabbreviated if possible) which is consistent throughout the documentation.

Charts may be used at various levels of detail; the number of levels depending on the size and complexity of the information processing problem. The level of detail should be such that the various parts and the interrelationship between the parts are comprehensible as a whole.

Typically there will be a chart of the whole system showing the main constituent parts and this will form the top of a hierarchy of charts; each lower level providing a more detailed description of one or more parts shown on the next higher level chart.

1 Scope and field of application

This International Standard specifies symbols to be used in information processing documentation and gives guidance on the conventions for their use in

- a) data flowcharts;
- b) program flowcharts;
- c) system flowcharts;
- d) program network charts;
- e) system resources charts.

2 Reference

ISO 2382/1, *Data processing — Vocabulary — Part 01: Fundamental terms.*¹⁾

3 Definitions

For the purpose of this International Standard the definitions in ISO 2382/1 and the following apply.

3.1 basic symbol: Symbol used when the precise nature or form of, for example, the process or data media is not known or when it is not necessary to depict the actual medium.

3.2 specific symbol: Symbol used when the precise nature or form of, for example, the process or data media is known and when it is necessary to depict the actual medium.

3.3 flowchart: Graphical representation of the definition, analysis, or method of solution of a problem in which symbols are used to represent operations, data, flow, equipment, etc.

4 Data flowchart

Data flowcharts represent the path of data in the solving of a problem and define processing steps as well as the various data media used.

A data flowchart consists of

- a) data symbols to indicate the existence of data; they may also indicate the medium used for this data;
- b) process symbols to indicate the process to be executed on data; they may also indicate the machine function which is used for this process;
- c) line symbols to indicate the data flow between processes and/or data media;
- d) special symbols to facilitate the reading and the writing of the flowchart.

1) At present at the stage of draft. (Revision of ISO 2382/1-1974.)

By definition, process symbols should be preceded and followed by data symbols. A data flowchart begins and ends with data symbols (except special symbols as specified in 9.4).

5 Program flowchart

Program flowcharts represent the sequence of operations in a program.

A program flowchart consists of

- a) process symbols for the actual processing operations including symbols that define the path to be followed taking into account the logical conditions;
- b) line symbols to indicate the flow of control;
- c) special symbols to facilitate the reading and the writing of the flowchart.

6 System flowchart

System flowcharts represent the control of operations and the data flow of a system.

A system flowchart consists of

- a) data symbols to indicate the existence of data; they may also indicate the medium used for this data;
- b) process symbols to indicate the operations to be executed on data, as well as to define the logical path to be followed;
- c) line symbols to indicate data flow between processes and/or data media as well as the control flow between processes;
- d) special symbols to facilitate the reading and writing of the flowchart.

7 Program network chart

Program network charts represent the path of program activations and the interactions to related data. Each program in a program network chart is shown only once, whereas in a system flowchart it may appear in more than one control flow.

A program network chart consists of

- a) data symbols to indicate the existence of data;
- b) process symbols to indicate the operations to be executed on data;

c) line symbols to show the flow between processes and data as well as the activations of processes;

d) special symbols to facilitate the reading and writing of the network charts.

8 System resources chart

System resources charts represent the configuration of data units and process units suitable for the solving of a problem or of a set of problems.

A system resources chart consists of

- a) data symbols to show input, output or storage devices;
- b) process symbols to represent processors, for example, central processing units, channels, etc.;
- c) line symbols to represent the data transfer between data devices and processors and control transfer between processors;
- d) special symbols to facilitate the reading and the writing of the system resources chart.

9 Symbols

9.1 Data symbols

9.1.1 Basic data symbols

9.1.1.1 Data

This symbol represents data, the medium being unspecified.

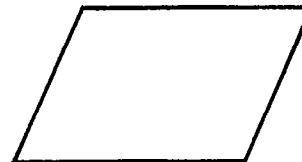

9.1.1.2 Stored data

This symbol represents stored data in a form suitable for processing, the medium being unspecified.

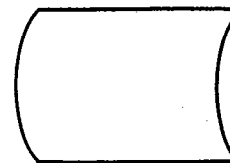

9.1.2 Specific data symbols

9.1.2.1 Internal storage

This symbol represents data, the medium being internal storage.

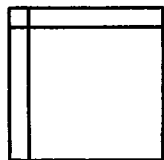

9.1.2.2 Sequential access storage

This symbol represents data that is only sequentially accessible, the medium being, for example, magnetic tape, tape cartridge, tape cassette.

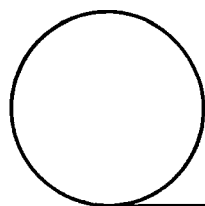

9.1.2.3 Direct access storage

This symbol represents data directly accessible, the medium being, for example, magnetic disk, drum, flexible disk.

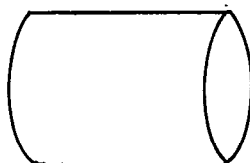

9.1.2.4 Document

This symbol represents human readable data, the medium being, for example, printed output, an OCR or MICR document, microfilm, tally roll, data entry forms.

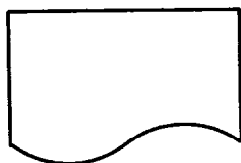

9.1.2.5 Manual input

This symbol represents data, the medium being of any type where the information is entered manually at the time of processing, for example, on-line keyboard, switch settings, push buttons, light pen, bar-code wand.



9.1.2.6 Card

This symbol represents data, the medium being cards, for example, punched cards, magnetic cards, mark sense cards, stub cards, mark scan cards.

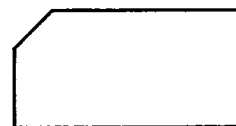

9.1.2.7 Punched tape

This symbol represents data, the medium being paper tape.



9.1.2.8 Display

This symbol represents data, the medium being of any type where the information is displayed for human use, for example, video screens, on-line indicators.

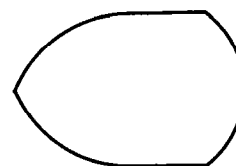

9.2 Process symbols

9.2.1 Basic process symbol

Process

This symbol represents any kind of processing function, for example, executing a defined operation or group of operations resulting in a change in value, form or location of information, or in the determination of which one of several flow directions is to be followed.



9.2.2 Specific process symbols

9.2.2.1 Predefined process

This symbol represents a named process consisting of one or more operations or program steps that are specified elsewhere, for example, a subroutine, a module.

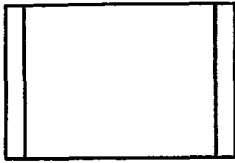

9.2.2.2 Manual operation

This symbol represents any process performed by a human being.

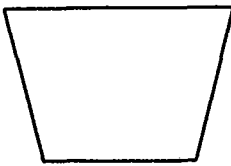

9.2.2.3 Preparation

This symbol represents modification of an instruction or group of instructions in order to affect some subsequent activity, for example, setting a switch, modifying an index register or initializing a routine.

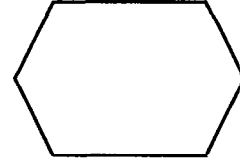

9.2.2.4 Decision

This symbol represents a decision or switching type function having a single entry but where there may be a number of alternative exits, one and only one of which may be activated following the evaluation of conditions defined within the symbol. The appropriate results of the evaluation may be written adjacent to the lines representing the paths (see 10.3.1.2).

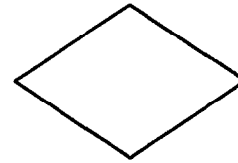

9.2.2.5 Parallel mode

This symbol represents the synchronization of two or more parallel operations.



Example:

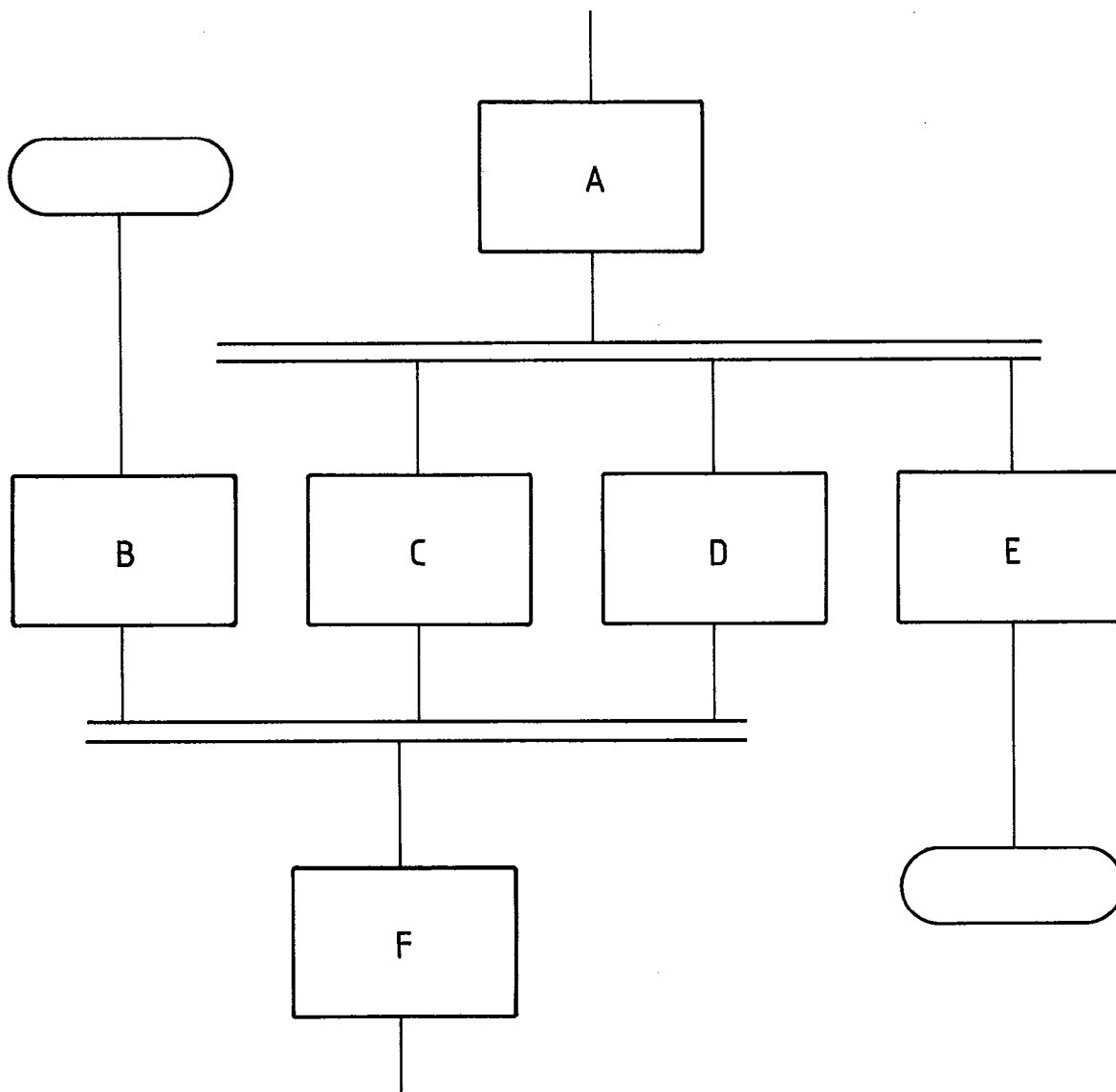

NOTE — Processes C, D and E cannot commence until process A has been completed ; similarly process F should await completion of B, C and D ; but process C may start and/or end before process D has started and/or ended respectively.

9.2.2.6 Loop limit

This symbol, in two parts, represents the beginning and end of a loop. The two parts of the symbol have the same identifier. The conditions for initialization, increment, termination, etc., appear inside the symbol at the beginning or at the end according to the location of the test operation.

Example:

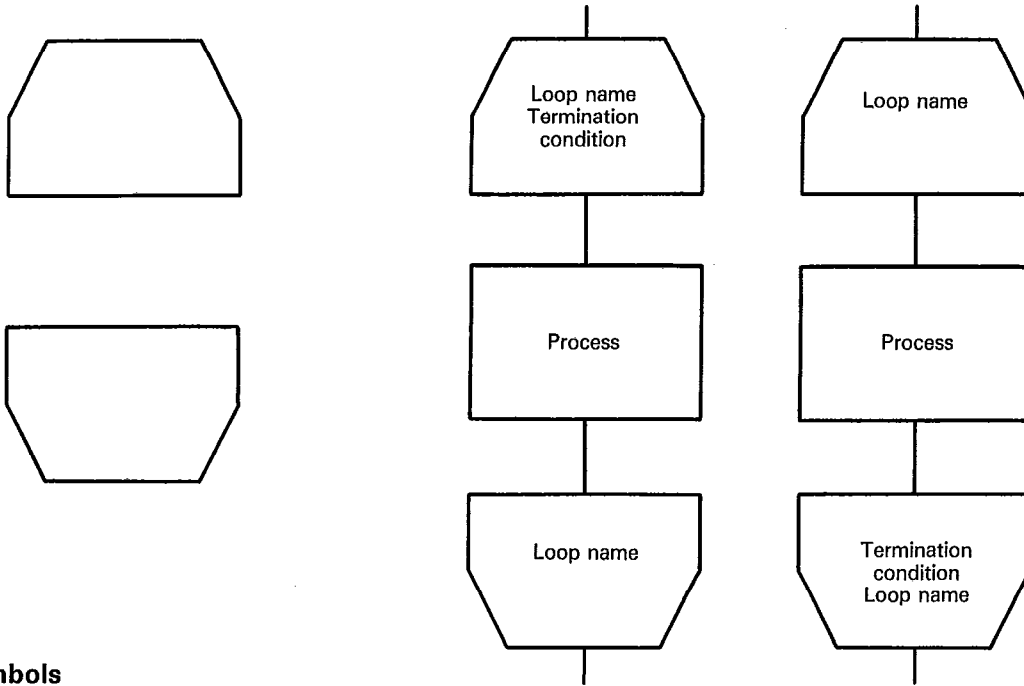

9.3 Line symbols

9.3.1 Basic line symbol

Line

This symbol represents the flow of data or control.



Solid or open arrowheads shall be added to indicate direction of flow where necessary (see 10.2.1.2) or may be added to enhance the readability.

9.3.2 Specific line symbols

9.3.2.1 Control transfer

This symbol represents immediate transfer of control from one process to another, sometimes with a chance of the direct return to the activating process after the activated process completes its actions. The type of control transfer should be named inside the symbol, for example, call, fetch, event.

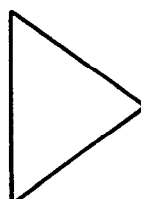

9.3.2.2 Communication link

This symbol represents data transfer by a telecommunication link.

**9.3.2.3** Dashed line

This symbol represents an alternative relationship between two or more symbols. The symbol is also used to surround an annotated area (see 9.4.3).



Examples:

a) in cases where one of a number of alternative outputs is used as an input to a process, or an output is used as an input for alternative processes, these symbols are connected by dashed lines.

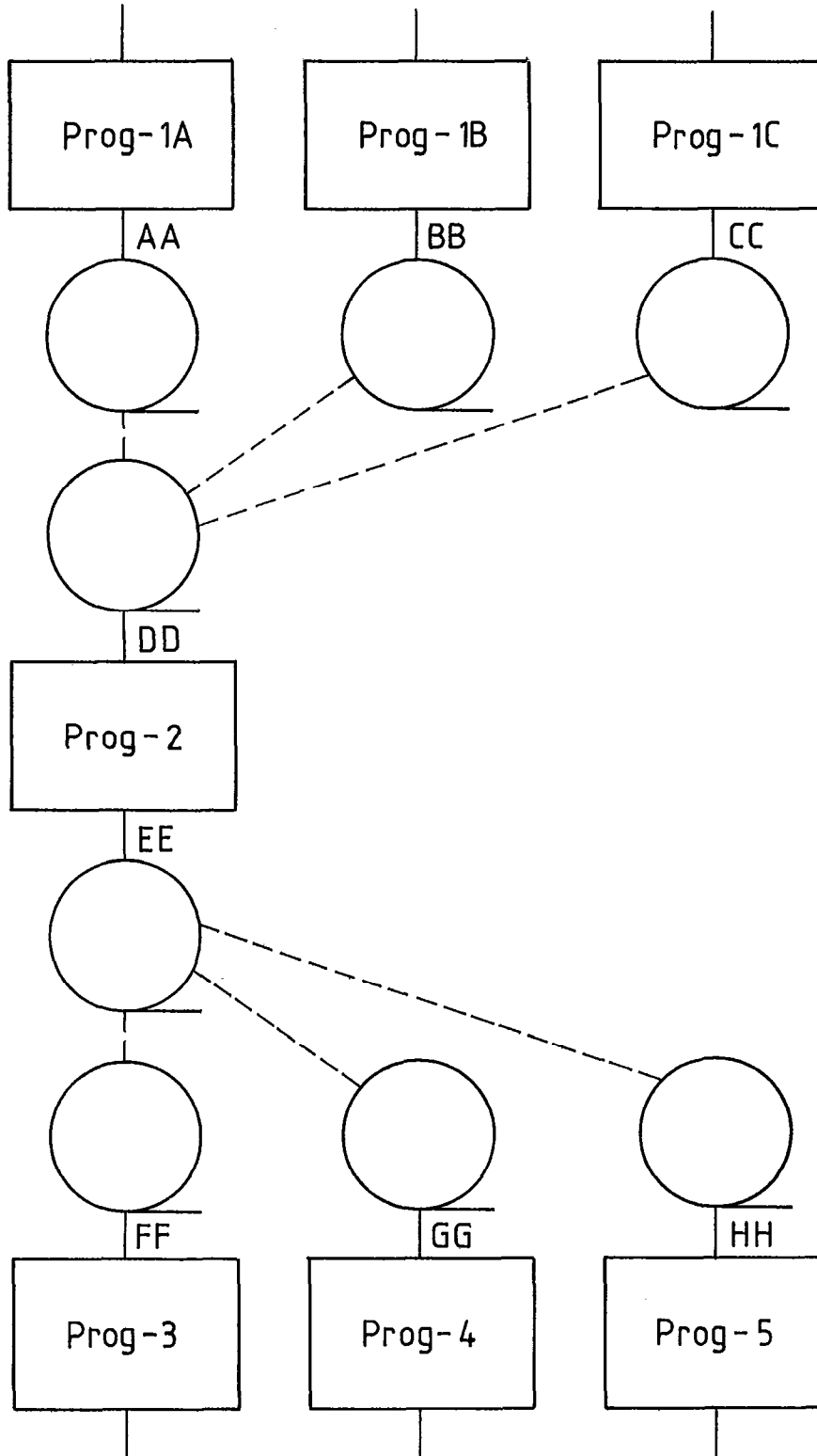

b) an output which is used as an input in a succeeding process will be connected to the input by a dashed line.

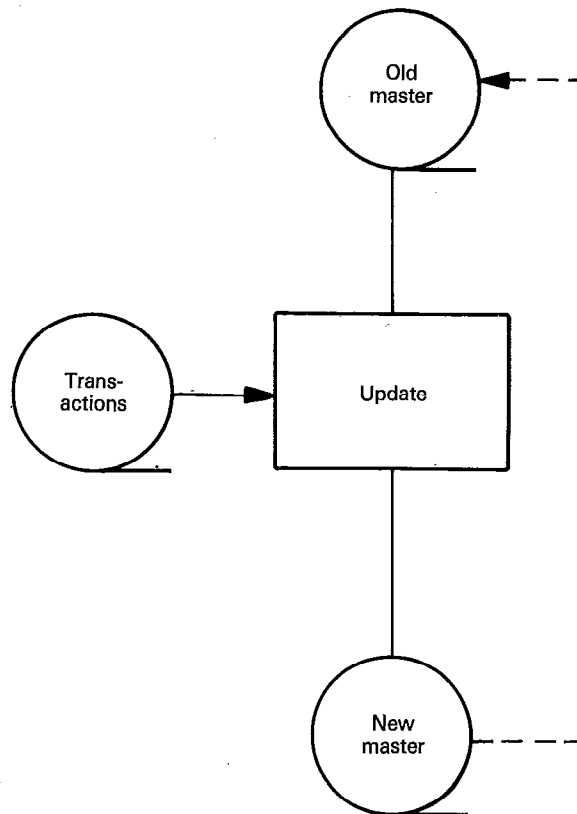

9.4 Special symbols

9.4.1 Connector

This symbol represents an exit to, or an entry from, another part of the same flowchart (see 10.2.2), and is used to break a line, and to continue it elsewhere. The corresponding connector symbols shall contain the same unique identification.



9.4.2 Terminator

This symbol represents an exit to, or an entry from, the outside environment, for example, start or end of a program flow, external use and origin or destination of data.



9.4.3 Annotation

This symbol is used to add, for clarification, descriptive comments or explanatory notes. The dashed lines on the annotation symbol are connected to the relevant symbol or may surround a group of symbols. The text of the comments and notes should be placed close to the bordering shape.



Example:

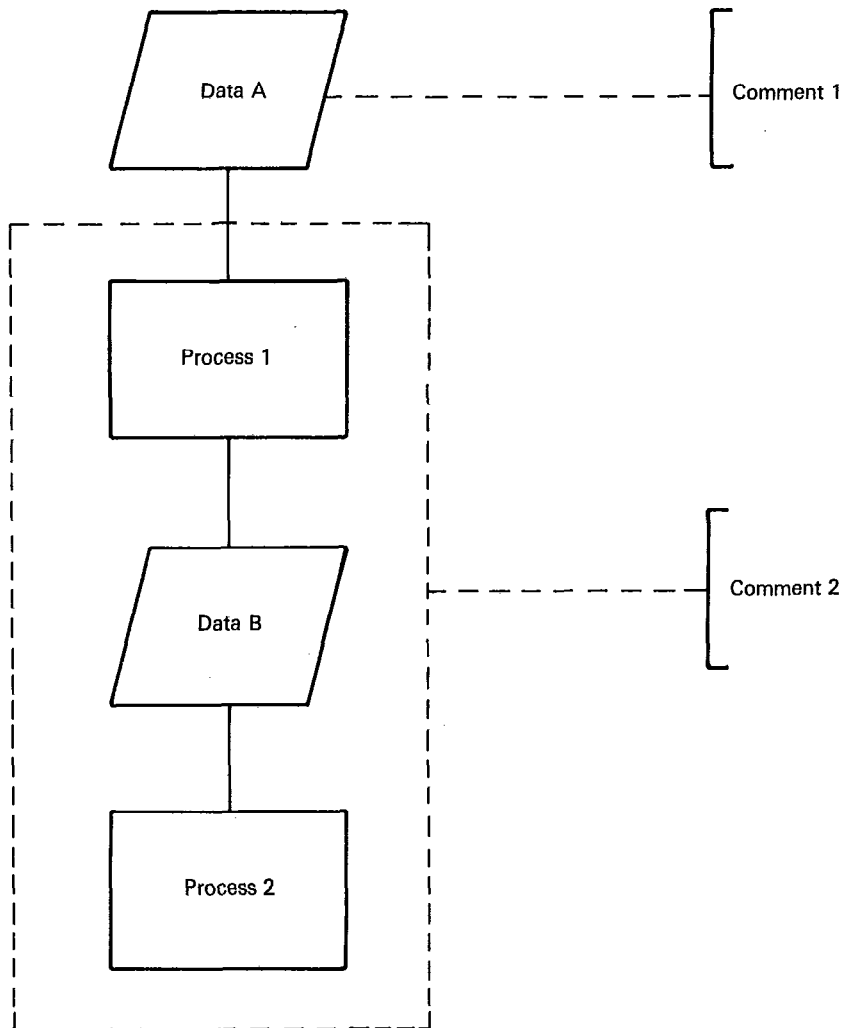

9.4.4 Ellipsis

This symbol (three dots) is used in charts to represent the omission of a symbol or a set of symbols where neither the type nor the number of symbols has to be defined. This symbol is used only in and between line symbols. This applies especially to charts showing general solutions with an open number of repetitions.

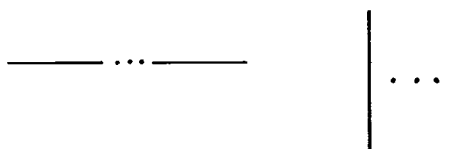

Example:

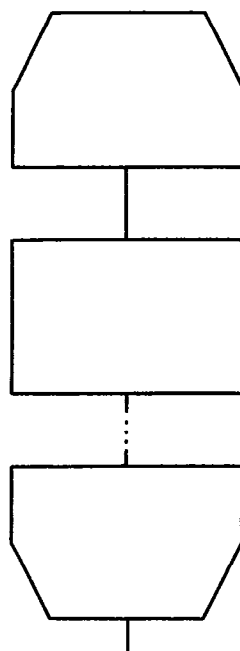

10 Conventions

10.1 Symbols

The purpose of a symbol is to identify graphically the function which it represents, irrespective of any text within the symbol.

10.1.1 Lay-out of charts

Symbols should be evenly spaced and connections should be kept to a reasonable length with a minimum number of long lines.

10.1.2 Shapes of symbols

The majority of symbols have been designed to allow the inclusion of text within the symbol.

The shapes depicted in this International Standard shall serve as a guide to the symbols actually used. In particular, the angles and other factors affecting the relative shape shall not be changed. Symbols should be constructed to uniform size as far as possible.

Symbols may be drawn in any orientation, but the horizontal orientation should be preferred where possible. The mirror image of a shape implies the same function, but is not preferred.

10.1.3 Symbol text

The minimum amount of text necessary for understanding the function of the symbol should be inserted within the symbol. The text should be written to read from left-to-right and top-to-bottom regardless of the flow direction.

Example:

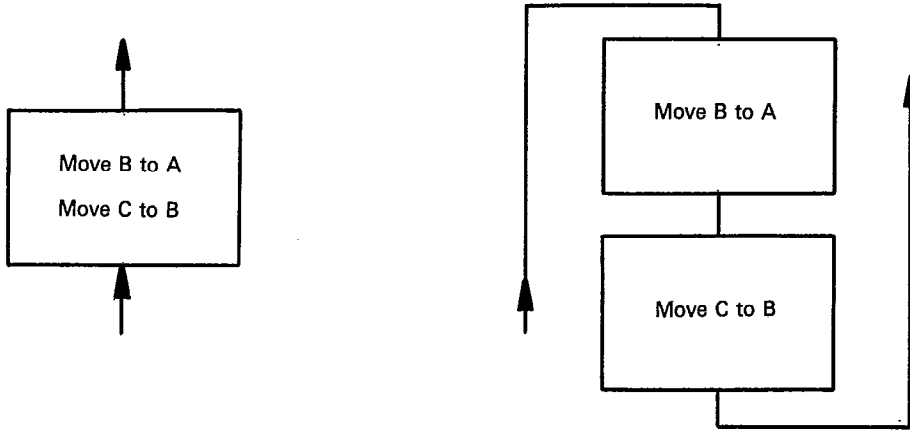

When the amount of text is so large that it cannot be conveniently fitted into the symbol, an annotation symbol may be used.

Where the use of annotation symbols would confuse or disrupt the flow of the chart, the text should be on a separate sheet and cross-referenced to the symbol.

10.1.4 Symbol identifier

This is an identifier associated with a symbol to identify the symbol for reference purposes in other elements of documentation (for example, in a program listing). A symbol identifier shall be placed above and to the left of the symbol, as shown below.

Example:



10.1.5 Symbol descriptor

This is a descriptor (for example, a descriptor for cross-referencing, representing specific use of a symbol, or to improve understanding of a function as part of a chart). A symbol description shall be placed above and to the right of the symbol as shown below.

Example:

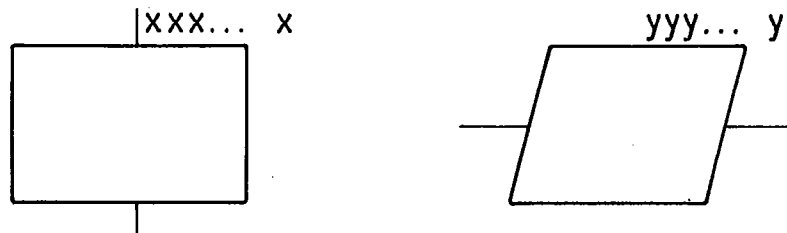

In system flowcharts a symbol depicting data media may, in many cases, represent output media as well as input media. For use as a reference to documentation the flowchart text for symbols representing output media shall be placed above and to the right of the symbol and flowchart text for symbols representing input media shall be placed at the bottom and to the right of the symbol.

Example:

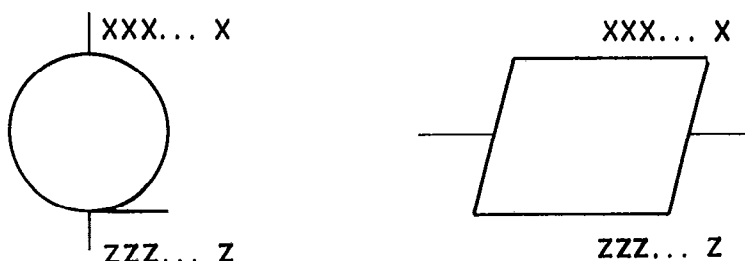

10.1.6 Detailed representation

Detailed representation is indicated by means of a striped symbol for process or data. A striped symbol indicates that a more detailed representation occurs elsewhere in the same set of documentation.

A striped symbol is any symbol in which a horizontal line is drawn within, and near the top, of the symbol and an identifier referring to the detailed representation of the symbol is placed between that line and the top line of the symbol.

The terminator symbol (see 9.4.2) should be used as the first and last symbol of the detailed representation. The first terminator symbol should contain a reference which also appears in the striped symbol, as indicated in the example.

Example:

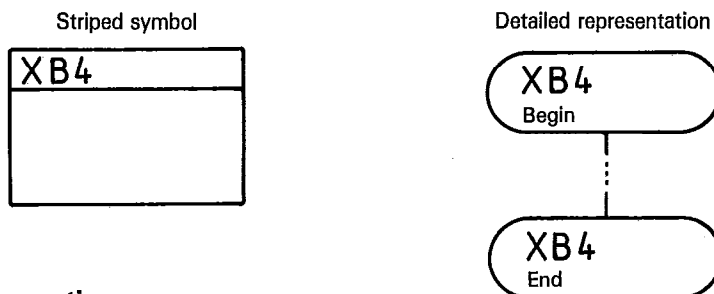

10.2 Conventions for connecting

10.2.1 Line symbols

Lines may indicate data flow or control flow.

10.2.1.1 Standard direction of flow

The standard direction of flow should be interpreted as left-to-right and top-to-bottom.

10.2.1.2 Use of arrows

Arrows should be used on lines whenever increased clarity will result (for example, at junctions). When the flow is not in the direction specified in 10.2.1.1, arrows should be used to indicate the direction.

10.2.1.3 Crossing of lines

Crossing of lines should be avoided. When lines cross, no logical interrelationship should be inferred and no changes in flow direction should be made. Lines which do cross have no logical interrelation. Therefore direction changes at crossing points are not possible.

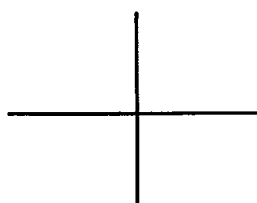

10.2.1.4 Joining of lines

Two or more incoming lines may join one outgoing line. When two or more lines join a line, the junction should be offset to increase clarity and solid or open arrowheads used to show flow direction.

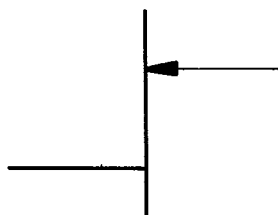

10.2.1.5 Interconnection

Lines should normally enter symbols either on the left or at the top and leave either on the right or at the bottom. They should be directed towards the centre of the symbols.

10.2.2 Connectors

10.2.2.1 Lines should be broken to avoid crossing of lines and long lines or when a chart is continued on other pages. The connector at the start of the break is called an out-connector and the one at the end of the break is called an in-connector.

10.2.2.2 Page references may be given with an annotation symbol to their connectors (see 9.4.3).

Example:

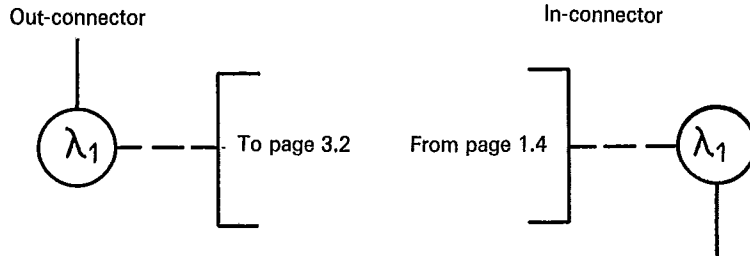

10.3 Special conventions

10.3.1 Multiple exits

10.3.1.1 Multiple exits from a symbol should be shown either:

- a) by several lines from the symbol to other symbols; or
- b) by a single line from the symbol which then branches into the appropriate number of lines.

Examples:

a)

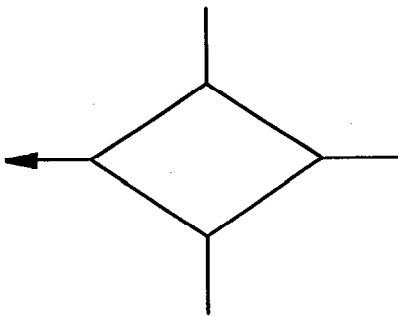

b)

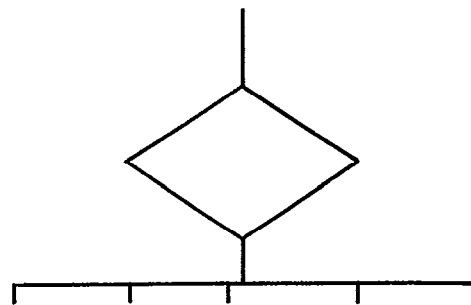

10.3.1.2 Each exit from a symbol should be accompanied by the appropriate condition values to show the logic path which it represents, so that the conditions and the associated references are identified.

Examples:

a)

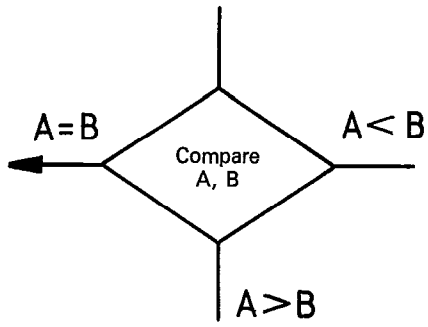

b)

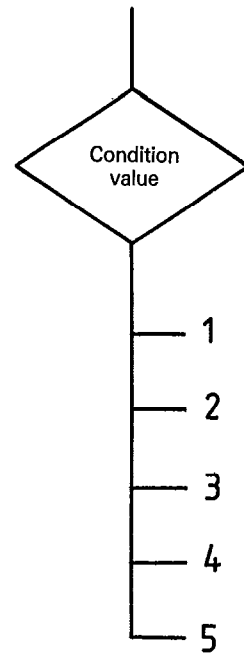

10.3.2 Repetitive representation

As an alternative to a single symbol with appropriate text, several symbols may be used in an overlay-pattern, each with descriptive text, as an alternative to using a single symbol with descriptive text. For example, the use or creation of multiple media or files, the production of multiple copies of printed reports, and different types of printed reports or punched card formats.

When the multiple symbols represent an ordered set, the ordering should be from front (first) to back (last).





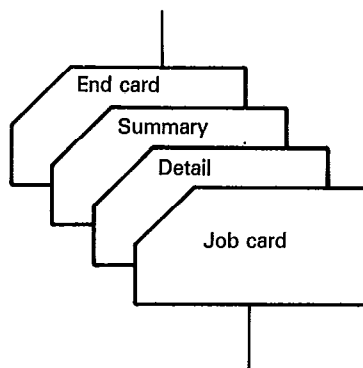
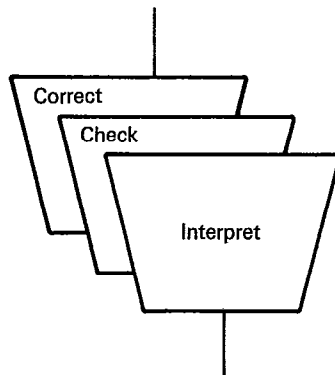
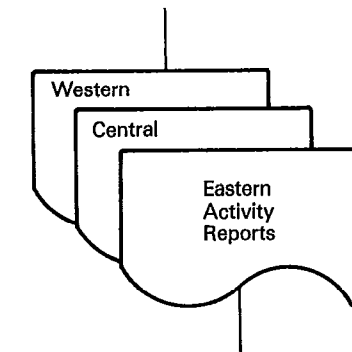

Lines may enter or leave from any point on the overlay symbols; however, the requirements of 10.2.1.5 still apply. The priority or sequential order of the multiple symbols is not altered by the point at which the lines enter or leave.



Example:

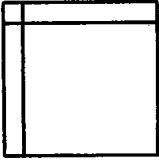
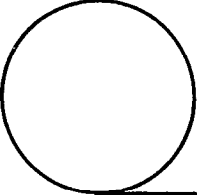





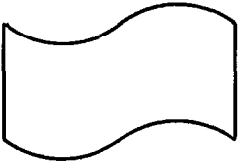
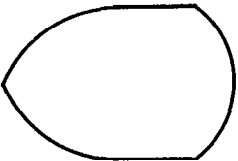

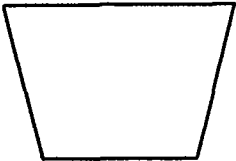
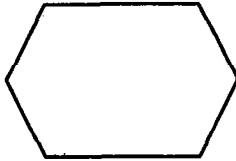
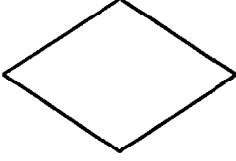
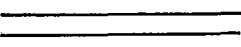

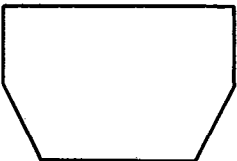
11 Consolidated table of symbols

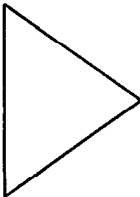
NOTE — Asterisk * indicates that symbol is used in the chart.

Symbol	Symbol name	Data flowchart	Program flowchart	System flowchart	Program network chart	System resources chart
DATA SYMBOLS						
Basic						
	Data (see 9.1.1.1)	*	*	*	*	*
	Stored data (see 9.1.1.2)	*		*	*	*
Specific						
	Internal storage (see 9.1.2.1)	*		*	*	*
	Sequential access storage (see 9.1.2.2)	*		*	*	*
	Direct access storage (see 9.1.2.3)	*		*	*	*
	Document (see 9.1.2.4)	*		*	*	*
	Manual input (see 9.1.2.5)	*		*	*	*
	Card (see 9.1.2.6)	*		*	*	*

Symbol	Symbol name	Data flowchart	Program flowchart	System flowchart	Program network chart	System resources chart
	Paper tape (see 9.1.2.7)	*		*	*	*
	Display (see 9.1.2.8)	*		*	*	*
PROCESS SYMBOLS						
Basic						
	Process (see 9.2.1)	*	*	*	*	*
Specific						
	Predefined process (see 9.2.2.1)		*	*	*	
	Manual operation (see 9.2.2.2)	*		*	*	
	Preparation (see 9.2.2.3)	*	*	*	*	
	Decision (see 9.2.2.4)		*	*		
	Parallel mode (see 9.2.2.5)		*	*	*	

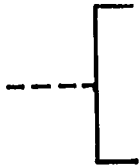
Symbol	Symbol name	Data flowchart	Program flowchart	System flowchart	Program network chart	System resources chart
	Loop limit (see 9.2.2.6)		*	*		
						
LINE SYMBOLS						
Basic						
	Line (see 9.3.1.1)	*	*	*	*	*
Specific						
	Control transfer (see 9.3.2.1)				*	
	Communication link (see 9.3.2.2)	*		*	*	*
	Dashed line (see 9.3.2.3)	*	*	*	*	*
SPECIAL SYMBOLS						
	Connector (see 9.4.1)	*	*	*	*	*
	Terminator (see 9.4.2)	*	*	*		

Symbol	Symbol name	Data flowchart	Program flowchart	System flowchart	Program network chart	System resources chart
	Annotation (see 9.4.3)	*	*	*	*	*
	Ellipsis (see 9.4.4)	*	*	*	*	*

Annex A

Example of data flowchart

(This annex does not form part of the standard.)

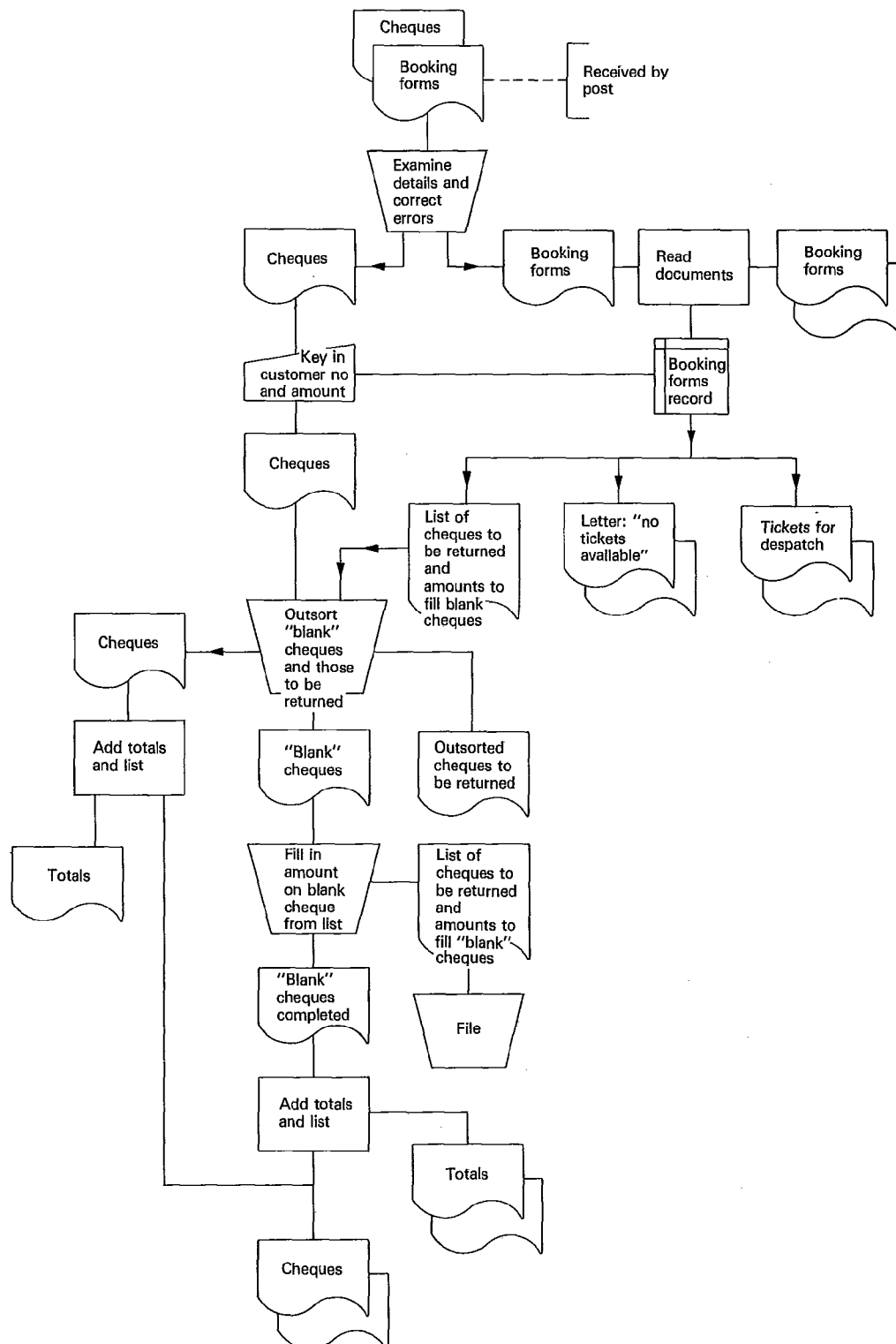

Annex B

Examples of program flowchart

(This annex does not form part of the standard.)

a)

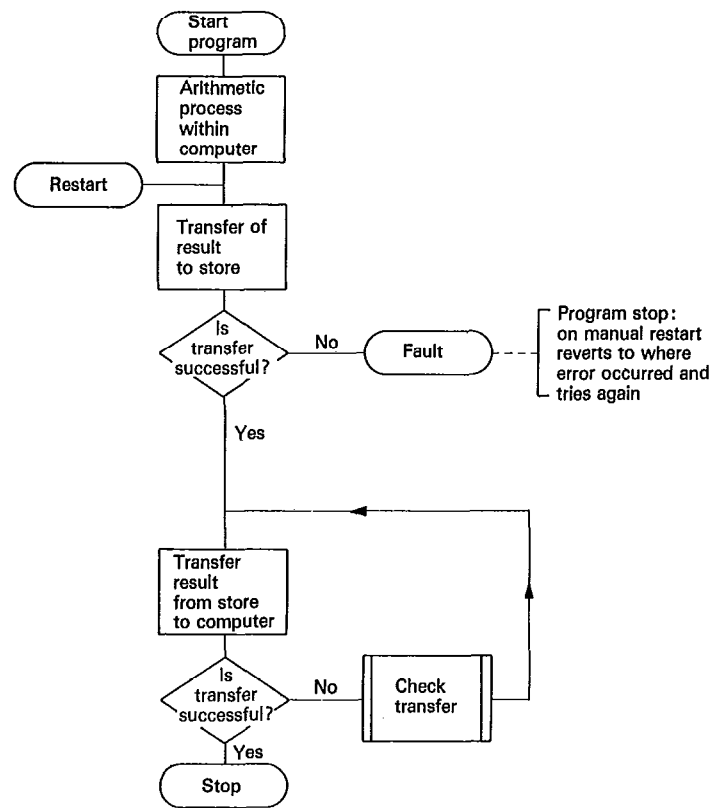

b)

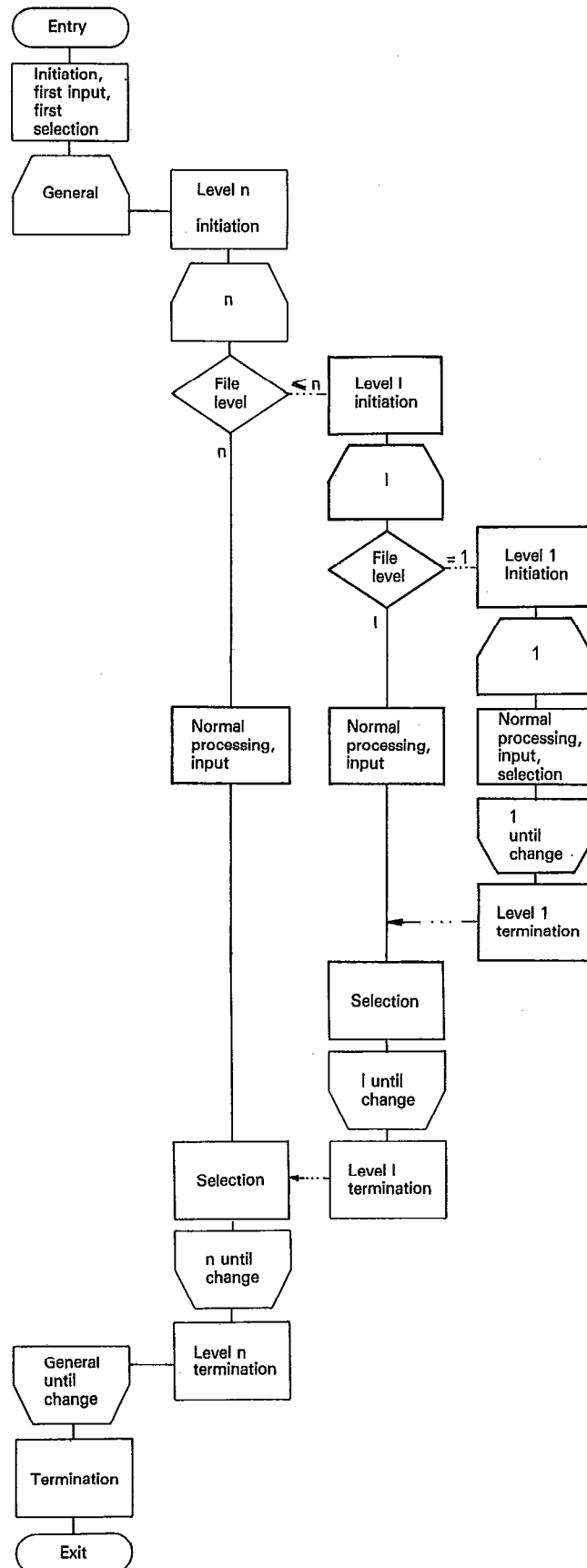

Annex C

Example of system flowchart

(This annex does not form part of the standard.)

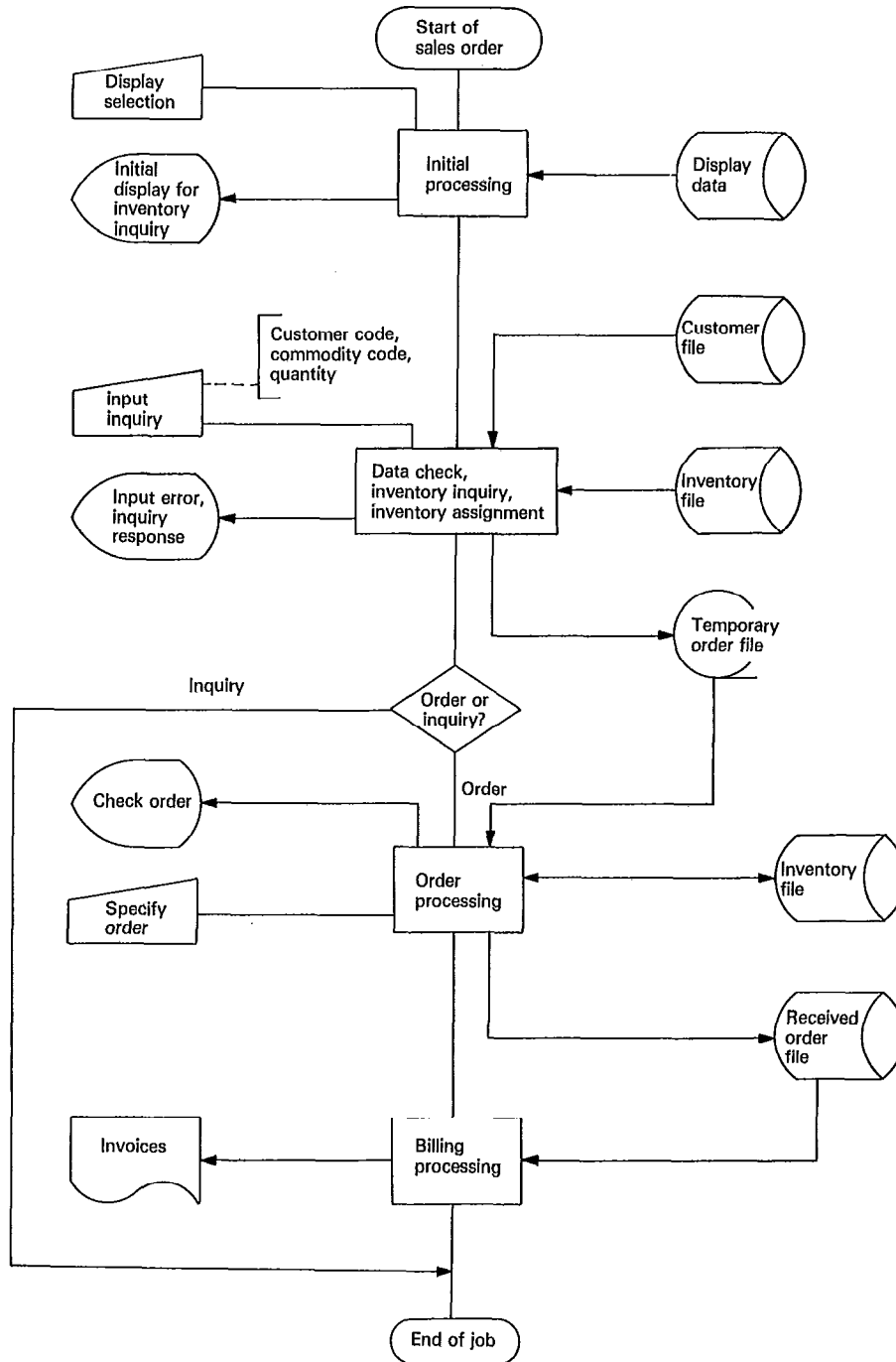

Annex D

Example of program network chart

(This annex does not form part of the standard.)

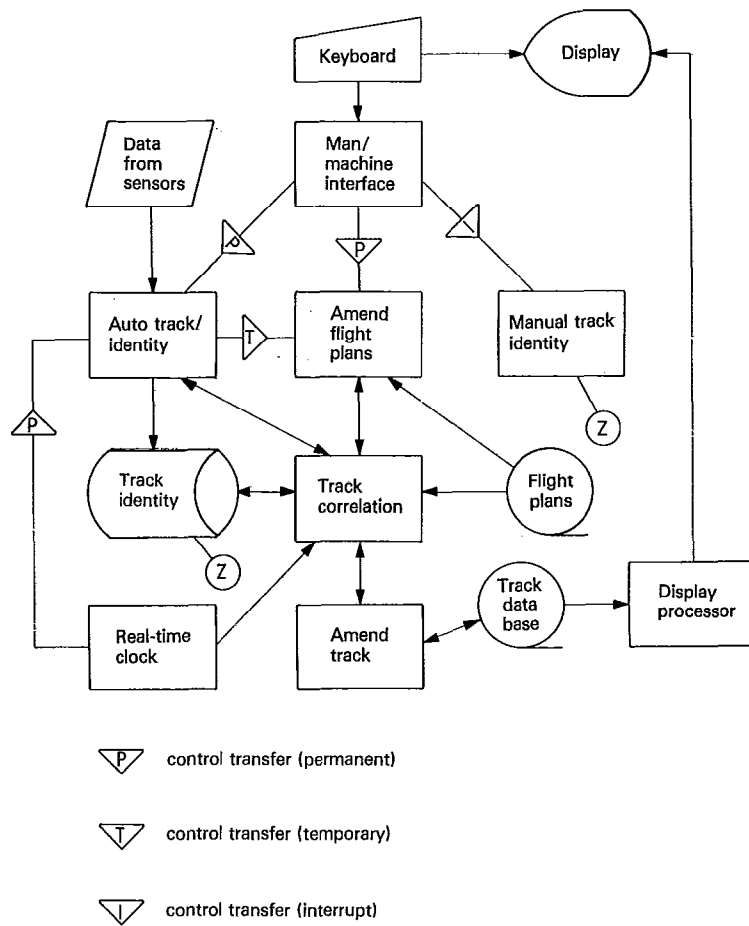

Annex E

Example of system resources chart

(This annex does not form part of the standard.)

