

---

---

**Milk — Determination of freezing point —  
Thermistor cryoscope method (Reference  
method)**

*Lait — Détermination du point de congélation — Méthode au cryoscope  
à thermistance (Méthode de référence)*



Reference numbers  
ISO 5764:2009(E)  
IDF 108:2009(E)

© ISO and IDF 2009

**PDF disclaimer**

This PDF file may contain embedded typefaces. In accordance with Adobe's licensing policy, this file may be printed or viewed but shall not be edited unless the typefaces which are embedded are licensed to and installed on the computer performing the editing. In downloading this file, parties accept therein the responsibility of not infringing Adobe's licensing policy. Neither the ISO Central Secretariat nor the IDF accepts any liability in this area.

Adobe is a trademark of Adobe Systems Incorporated.

Details of the software products used to create this PDF file can be found in the General Info relative to the file; the PDF-creation parameters were optimized for printing. Every care has been taken to ensure that the file is suitable for use by ISO member bodies and IDF national committees. In the unlikely event that a problem relating to it is found, please inform the ISO Central Secretariat at the address given below.



**COPYRIGHT PROTECTED DOCUMENT**

© ISO and IDF 2009

All rights reserved. Unless otherwise specified, no part of this publication may be reproduced or utilized in any form or by any means, electronic or mechanical, including photocopying and microfilm, without permission in writing from either ISO or IDF at the respective address below.

ISO copyright office  
Case postale 56 • CH-1211 Geneva 20  
Tel. + 41 22 749 01 11  
Fax + 41 22 749 09 47  
E-mail [copyright@iso.org](mailto:copyright@iso.org)  
Web [www.iso.org](http://www.iso.org)

International Dairy Federation  
Diamant Building • Boulevard Auguste Reyers 80 • B-1030 Brussels  
Tel. + 32 2 733 98 88  
Fax + 32 2 733 04 13  
E-mail [info@fil-idf.org](mailto:info@fil-idf.org)  
Web [www.fil-idf.org](http://www.fil-idf.org)

Published in Switzerland

## Contents

Page

Foreword.....	iv
Foreword.....	v
1 Scope .....	1
2 Normative references .....	1
3 Terms and definitions .....	1
4 Principle.....	2
5 Reagents .....	2
6 Apparatus .....	3
7 Sampling.....	4
8 Calibration of the thermistor cryoscope .....	4
9 Preparation of test sample.....	5
9.1 Preparation .....	5
9.2 Sample condition .....	6
10 Procedure .....	6
10.1 Preliminary checks .....	6
10.2 Routine calibration check .....	6
10.3 Determination.....	6
11 Calculation and expression of results.....	7
11.1 Calculation.....	7
11.2 Expression of results .....	7
12 Precision.....	7
12.1 Interlaboratory test .....	7
12.2 Repeatability.....	7
12.3 Reproducibility.....	7
13 Test report .....	8
Annex A (informative) Interlaboratory trial on bovine milk.....	9
Annex B (informative) Interlaboratory trial on raw ovine and caprine milk .....	11
Annex C (informative) Guidelines for the application of routine thermistor cryoscope methods .....	13
Annex D (informative) Adjustment of the freezing point value used as the reference for genuine milk .....	16
Bibliography .....	17

## Foreword

**ISO (the International Organization for Standardization)** is a worldwide federation of national standards bodies (ISO member bodies). The work of preparing International Standards is normally carried out through ISO technical committees. Each member body interested in a subject for which a technical committee has been established has the right to be represented on that committee. International organizations, governmental and non-governmental, in liaison with ISO, also take part in the work. ISO collaborates closely with the International Electrotechnical Commission (IEC) on all matters of electrotechnical standardization.

International Standards are drafted in accordance with the rules given in the ISO/IEC Directives, Part 2.

The main task of technical committees is to prepare International Standards. Draft International Standards adopted by the technical committees are circulated to the member bodies for voting. Publication as an International Standard requires approval by at least 75 % of the member bodies casting a vote.

Attention is drawn to the possibility that some of the elements of this document may be the subject of patent rights. ISO shall not be held responsible for identifying any or all such patent rights.

International Standard ISO 5764|IDF 108 was prepared by Technical Committee ISO/TC 34, *Food products*, Subcommittee SC 5, *Milk and milk products*, and the International Dairy Federation (IDF). It is being published jointly by ISO and IDF.

This third edition of ISO 5764|IDF 108 cancels and replaces the second edition (ISO 5764|IDF 108:2002), the scope of which has been technically revised.

## Foreword

**IDF (the International Dairy Federation)** is a non-profit organization representing the dairy sector worldwide. IDF membership comprises National Committees in every member country as well as regional dairy associations having signed a formal agreement on cooperation with IDF. All members of IDF have the right to be represented on the IDF Standing Committees carrying out the technical work. IDF collaborates with ISO in the development of standard methods of analysis and sampling for milk and milk products.

Draft International Standards adopted by the Action Teams and Standing Committees are circulated to the National Committees for voting. Publication as an International Standard requires approval by at least 50 % of the IDF National Committees casting a vote.

Attention is drawn to the possibility that some of the elements of this document may be the subject of patent rights. IDF shall not be held responsible for identifying any or all such patent rights.

International Standard ISO 5764|IDF 108 was prepared by Technical Committee ISO/TC 34, *Food products*, Subcommittee SC 5, *Milk and milk products*, and the International Dairy Federation (IDF). It is being published jointly by ISO and IDF.

All work was carried out by the Joint IDF-ISO Action Team on *Water*, of the Standing Committee on *Main components in milk*, under the aegis of its project leader, Mrs. S. Orlandini (IT).

This edition of ISO 5764|IDF 108 cancels and replaces ISO 5764|IDF 108:2002, the scope of which has been technically revised.

.....

# Milk — Determination of freezing point — Thermistor cryoscope method (Reference method)

## 1 Scope

This International Standard specifies a reference method for the determination of the freezing point of raw bovine milk, heat-treated whole, reduced fat and skimmed bovine milk, as well as raw ovine and caprine milk, by using a thermistor cryoscope.

The freezing point can be used to estimate the proportion of extraneous water in milk. Calculation of the amount of extraneous water is subject to daily and seasonal variations, and is not within the scope of this International Standard.

Results obtained from samples with a titratable acidity exceeding 20 ml of 0,1 mol/l sodium hydroxide solution per 10 g of non-fat solids are not representative of the original milk.

NOTE 1 Sterilization and vacuum pasteurization can affect the freezing point of milk (see Reference [5]).

NOTE 2 The method uses plateau-timed instruments. For routine measurements, other thermistor cryoscope methods, i.e. fixed time procedures, can be used. Guidelines for the application of other procedures are given in Annex C.

NOTE 3 The limit value mentioned for the titratable acidity in Clause 1 and 9.2 applies to bovine milk. It is possible that the limit values for ovine and caprine milk are higher.

## 2 Normative references

The following referenced documents are indispensable for the application of this document. For dated references, only the edition cited applies. For undated references, the latest edition of the referenced document (including any amendments) applies.

ISO 3696, *Water for analytical laboratory use — Specification and test methods*

ISO 6091, *Dried milk — Determination of titratable acidity (Reference method)*<sup>1)</sup>

## 3 Terms and definitions

For the purposes of this document, the following terms and definitions apply.

### 3.1

#### freezing point of milk

temperature value obtained using the method specified in this International Standard

NOTE The freezing point is expressed in millidegrees Celsius.

---

1) Equivalent to IDF 86.

## 4 Principle

A test sample of milk is supercooled to an appropriate temperature. Crystallization is induced by means sufficient to cause an instantaneous release of heat with an accompanying warming of the sample to a temperature plateau. The plateau is reached when the temperature rise has not exceeded 0,5 m°C over the previous 20 s. The temperature thus attained corresponds to the freezing point of the test sample.

The instrument is calibrated by adjusting it to give the correct readings for two sodium chloride standard solutions, using the same procedure as for test portions of milk.

## 5 Reagents

During the analysis, unless otherwise stated, use only reagents of recognized analytical grade.

**5.1 Water**, in accordance with ISO 3696 grade 2 or water of equivalent quality distilled from borosilicate glass apparatus.

Boil the water and cool it to 20 °C ± 2 °C shortly before use.

**5.2 Sodium chloride (NaCl)**, finely ground, dried in the electric furnace (6.7) at 300 °C ± 25 °C for 5 h or, alternatively, dried in the drying oven (6.8) at 130 °C ± 2 °C for at least 24 h, then cooled to room temperature in a desiccator (6.9).

**5.3 Sodium chloride standard solutions.**

Preferably, make up the sodium chloride standard solution on a gram per kilogram basis (see Table 1, leftmost column) by weighing the required amount of prepared dry sodium chloride (5.2) to the nearest 0,1 mg and dissolving it in 1 000 g ± 0,1 g of water (5.1). Store standard solutions at about 5 °C in well-stoppered polyethylene bottles (6.10) of capacity not greater than 250 ml.

Alternatively, weigh, to the nearest 0,1 mg, the appropriate amount (see Table 1, middle column) of prepared dry sodium chloride (5.2) in a weighing bottle (6.5). Dissolve in water (5.1) and transfer quantitatively to a 1 000 ml one-mark volumetric flask (6.6). Dilute to the 1 000 ml mark with water (5.1) at 20 °C ± 2 °C and mix.

**Table 1 — Freezing point of sodium chloride standard solutions**

NaCl solution g/kg	NaCl solution at 20 °C g/l	Freezing point m°C
6,763	6,731	-400,0
6,901	6,868	-408,0
7,625	7,587	-450,0
8,489	8,444	-500,0
8,662	8,615	-510,0
8,697	8,650	-512,0
8,835	8,787	-520,0
9,008	8,959	-530,0
9,181	9,130	-540,0
9,354	9,302	-550,0
9,475	9,422	-557,0
10,220	10,161	-600,0



Before using a standard solution, gently invert and rotate the bottle several times to mix its contents thoroughly.

Do not agitate the standard solution violently at any time, as this can lead to incorporation of air. Pour samples of standard solutions from the bottles; never use pipettes for this purpose. Do not use standard solutions from bottles less than one-quarter full, or more than 2 months old, or containing visible moulds.

Only use unpreserved sodium chloride standard solutions for this reference method. For routine methods, sodium chloride standard solutions with a fungicidal or fungistatic agent may be used. For guidance, see Annex C.

## 6 Apparatus

Usual laboratory apparatus and, in particular, the following.

**6.1 Cryoscope**, consisting of a thermostatically controlled cooling device, a thermistor probe with associated circuit, a read-out device, a sample agitator and a crystallization device (see Figure 1).

### 6.1.1 Cooling device.

Several types of thermostatically controlled cooling devices can be used, e.g.:

- a) immersion type: a cooling bath with a suitable buffer capacity;
- b) circulation type: a continuous stream of cooling liquid around the sample tube;
- c) cooling block type: a cooling block with a small amount of cooling liquid.

After the initiation of freezing, keep the temperature of the cooling liquid around the sample tube constant at  $-7,0\text{ °C} \pm 0,5\text{ °C}$ .

NOTE A suitable cooling liquid is a 33 % (volume fraction) aqueous solution of propylene glycol.

### 6.1.2 Measuring device, associated circuitry and read-out device.

The thermistor shall be of the glass probe type with diameter of  $1,60\text{ mm} \pm 0,4\text{ mm}$  and an electrical resistance of between  $3\ \Omega$  and  $30\text{ k}\Omega$  at  $0\text{ °C}$ .

The type and dimensions of the shank material (including a possible filler) shall not allow a heat transfer into the sample greater than  $2,5 \times 10^{-3}\text{ J/s}$ , under operating conditions.

When the probe is in measurement position, the thermistor bead shall lie on the axis of the sample tube and at equal distances from the inner walls and the inner bottom of the tube (see Figure 1).

The thermistor and the associated circuitry shall show a discrimination of  $1\text{ m°C}$  or better over a range of  $-400\text{ m°C}$  to  $-600\text{ m°C}$ .

The linearity of the circuit shall be such that no error greater than  $1\text{ m°C}$  is introduced at any point within the range of  $-400\text{ m°C}$  to  $-600\text{ m°C}$  when the instrument is correctly operated.

The read-out device shall provide a discrimination of  $1\text{ m°C}$  or better over a range of at least  $0\text{ m°C}$  to  $-1\ 000\text{ m°C}$ .

### 6.1.3 Stirring wire, inert to milk, used to stir the test portion during cooling.

The stirring wire shall be adjustable for amplitude and mounted vertically in accordance with the manufacturer's instructions. The wire shall vibrate laterally with an amplitude of 2 mm to 3 mm to ensure that the temperature within the test portion remains uniform during cooling. At no time during its normal stirring operation shall the wire strike the glass probe or the wall of the tube.

**6.1.4 Device for initiating freezing**, that, when operated, instantaneously initiates freezing of the test portion when reaching  $-3,0\text{ }^{\circ}\text{C}$ .

The stirring wire (6.1.3) may be used for this purpose. One method is to increase the amplitude of vibration for 1 s to 2 s such that the stirring wire strikes the wall of the sample tube (6.2).

**6.2 Sample tubes**, symmetrical, made of borosilicate glass, of length  $50,5\text{ mm} \pm 0,2\text{ mm}$ , of external diameter  $16,0\text{ mm} \pm 0,2\text{ mm}$  and of internal diameter  $13,7\text{ mm} \pm 0,3\text{ mm}$  (see Figure 1).

The wall thickness throughout the tube shall not vary by more than 0,1 mm.

The tubes shall be equally shaped so that equal freezing points are obtained for equal volumes of the same solution. Check on equality before using the tubes.

**6.3 Main power supply**, capable of operating within the manufacturer's specifications.

**6.4 Analytical balance**, capable of weighing to the nearest 0,1 mg.

**6.5 Weighing bottle**.

**6.6 One-mark volumetric flasks**, capacity 1 000 ml, ISO 1042 [2] class A.

**6.7 Electric furnace**, capable of being maintained at  $300\text{ }^{\circ}\text{C} \pm 25\text{ }^{\circ}\text{C}$ ; or

**6.8 Drying oven**, capable of being maintained at  $130\text{ }^{\circ}\text{C} \pm 2\text{ }^{\circ}\text{C}$ .

**6.9 Desiccator**, containing silica gel with hygrometer indicator.

**6.10 Polyethylene bottles**, of maximum capacity 250 ml, with a suitable stopper.

## 7 Sampling

Sampling is not part of the method specified in this International Standard. A recommended sampling method is given in ISO 707 | IDF 50 [1].

It is important that the laboratory receive a sample that is truly representative and that has not been damaged or changed during transport or storage.

Preferably, test samples immediately upon arrival at the laboratory. Provided it remains in a representative state, a test sample of raw milk may be stored at a temperature of between  $0\text{ }^{\circ}\text{C}$  and  $6\text{ }^{\circ}\text{C}$  for up to 48 h after sampling. For a test sample of processed milk, respect its shelf life.

## 8 Calibration of the thermistor cryoscope

Ensure that the cryoscope (6.1) is in working condition in accordance with the manufacturer's instructions. Check the position of the probe, the amplitude of vibration of the stirring wire, and the temperature of the cooling device (6.1.1).

Select two sodium chloride standard solutions (see Table 1) which closely bracket the expected value of the freezing point of the milk to be tested. The difference in the freezing points between the two selected sodium chloride standard solutions shall not be less than  $100\text{ m}^{\circ}\text{C}$ . Ensure that the temperatures of the selected sodium chloride standard solutions and that of the test sample are similar.

Pour  $2,5\text{ ml} \pm 0,1\text{ ml}$  of the sodium chloride standard solutions into clean, dry sample tubes (6.2) and calibrate the instrument as indicated by the manufacturer. Use sample tubes (6.2) of the same type as those being used during testing of the sample. Thereafter, the thermistor cryoscope is ready for use.

Dimensions in millimetres

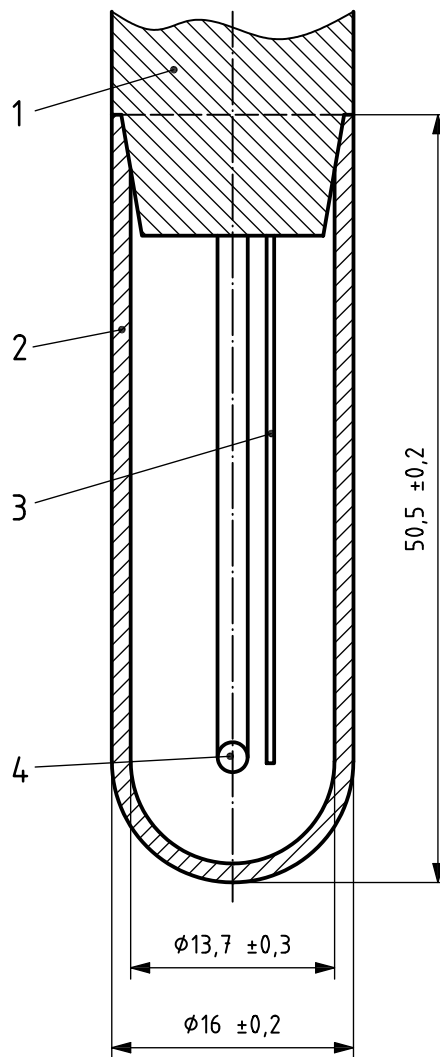

**Key**

- 1 mandrel
- 2 sample tube
- 3 stirring wire
- 4 thermistor bead

**Figure 1 — Details of sample tube, thermistor probe, and stirring wire**

**9 Preparation of test sample**

**9.1 Preparation**

If necessary, remove any visible foreign bodies or solid butterfat from the test sample by filtering into a clean, dry vessel. Mix the sample gently. Use a filter that is inert to milk and effective when used at laboratory temperature.

Test the samples at their storage temperature or after having reached the laboratory temperature before commencing the determination. The test samples and the sodium chloride standard solutions shall have similar temperatures when commencing the determination (see also Clause 8).

## 9.2 Sample condition

If doubts exist about the sample condition, determine the titratable acidity of the test sample by the method specified in ISO 6091 as far as possible at the same time as determining the freezing point.

Results obtained from test samples with a titratable acidity exceeding 20 ml of 0,1 mol/l sodium hydroxide solution per 10 g of non-fat solids are not representative of the original milk (see Clause 1, Note 3).

## 10 Procedure

### 10.1 Preliminary checks

Carry out preliminary instrument checks in accordance with the manufacturer's instructions.

### 10.2 Routine calibration check

Before each series of determinations, measure the freezing point of a sodium chloride standard solution (5.3) (e.g. a solution with a freezing point of  $-512 \text{ m}^\circ\text{C}$ ) until the values obtained in two consecutive determinations do not differ by more than  $1 \text{ m}^\circ\text{C}$ .

If the arithmetic mean of the two results differs from the freezing point of the sodium chloride standard solution used by more than  $2 \text{ m}^\circ\text{C}$ , recalibrate the cryoscope as specified in Clause 8.

If the cryoscope is in continuous use, carry out a routine calibration check at least once every hour.

### 10.3 Determination

Gently invert and rotate the sample container several times to mix its contents, thereby avoiding the incorporation of air.

Using a pipette, transfer a test portion of  $2,5 \text{ ml} \pm 0,1 \text{ ml}$  of the prepared test sample (9.1) into a clean and dry sample tube (6.2).

Ensure that the probe and the stirring wire (6.1.3) are clean and dry. If necessary, wipe them carefully with a soft, clean, and lintless tissue.

Insert the sample tube into the calibrated cryoscope (6.1) according to the manufacturer's instructions. Start the instrument to cool the test portion and initiate freezing at  $-3,0 \text{ }^\circ\text{C} \pm 0,1 \text{ }^\circ\text{C}$ .

The plateau is reached when the temperature rise over the previous 20 s has not exceeded  $0,5 \text{ m}^\circ\text{C}$ . For instruments with a resolution not better than  $1 \text{ m}^\circ\text{C}$ , the plateau is reached as soon as the temperature has remained constant for 20 s. Record this temperature.

If, for any reason, freezing is initiated before reaching a temperature of  $-3,0 \text{ }^\circ\text{C} \pm 0,1 \text{ }^\circ\text{C}$ , abandon the test. Repeat the determination with another test portion of 2,5 ml.

If this second test portion also freezes too early, warm the remaining test sample (or part of it) in a closed container at  $40 \text{ }^\circ\text{C} \pm 2 \text{ }^\circ\text{C}$  for 5 min in order to melt any crystalline fat. Cool the thus re-prepared test sample (or part of it) to the laboratory temperature (see also 9.1) and immediately repeat the test on a test portion of 2,5 ml.

**NOTE** The time between the initiation of freezing and the attainment of the plateau value, as well as the time during which the temperature remains constant, differs from sample to sample and is considerably shorter for water and sodium chloride standard solutions than for milk.

Remove the sample tube after each determination and rinse the thermistor probe and the stirring wire with water. Wipe the thermistor probe and the stirring wire with a soft, clean, and lintless tissue.

If required to carry out a second determination, use another test portion. If the two freezing points differ by more than the repeatability value (see 12.2), discard the results and carry out two consecutive determinations on fresh test portions.

## 11 Calculation and expression of results

### 11.1 Calculation

If the calibration is confirmed by the result of the routine calibration check (10.2), take as the result the value obtained or, if multiple determinations have been carried out, the mean of the values obtained. If the calibration is not confirmed, repeat the procedure (Clause 10).

### 11.2 Expression of results

Express the test result of the freezing point to three significant figures.

## 12 Precision

### 12.1 Interlaboratory test

The values for the repeatability and reproducibility were derived from the results of interlaboratory tests of the method, which are summarized in Annexes A and B.

The values derived from these interlaboratory tests may not be applicable to concentration ranges and matrices other than those given.

### 12.2 Repeatability

The absolute difference between two single test results obtained with the same method on identical test material in the same laboratory by the same operator using the same equipment within a short interval of time, shall in not more than 5 % of cases be greater than:

- a) bovine milk: 4 m°C;
- b) caprine milk: 4 m°C;
- c) ovine milk: 6 m°C.

### 12.3 Reproducibility

The absolute difference between two single test results, obtained with the same method on identical test material in different laboratories with different operators using different equipment, shall in not more than 5 % of cases be greater than:

- a) bovine milk: 6 m°C;
- b) caprine milk: 9 m°C;
- c) ovine milk: 10 m°C.

### **13 Test report**

The test report shall contain at least the following information:

- a) all the information required for the complete identification of the sample;
- b) the sampling method used, if known;
- c) the test method used, with reference to this International Standard;
- d) all operating details not specified in this International Standard, or regarded as optional, together with details of any incident which may have influenced the result(s);
- e) the titratable acidity, if determined;
- f) the test result(s) obtained, or, if the repeatability has been checked, the final quoted result(s) obtained.

## Annex A (informative)

### Interlaboratory trial on bovine milk

#### A.1 General

After a preliminary study in 1998-10, an international collaborative test involving 19 laboratories and 13 countries was carried out in 1999-09. The test included 18 test samples, divided into 36 blind duplicates:

- a) six pairs of UHT skimmed milk samples at three different levels;
- b) six pairs of UHT whole milk samples at three different levels;
- c) six pairs of raw milk samples at three different levels.

The test was organized by the Netherlands Milk Control Station, Zutphen (NL) and the Inspectorate for Health Protection, Leeuwarden (NL). The test samples were prepared and distributed by Cecalait, Poligny (FR), which also performed the statistical analysis in accordance with ISO 5725-1 [3] and ISO 5725-2 [4] to give the precision data shown in Tables A.1 to A.3.

#### A.2 Test results

**Table A.1 — Results for UHT skim milk**

Sample	1	2	3	4	5	6	Grand mean <sup>a</sup>
No. participating labs after eliminating outliers	17	16	17	18	18	17	
Mean value, m°C	-497,4	-498,8	-512,0	-518,1	-536,1	-539,4	-517,0
Repeatability standard deviation, $s_r$ , m°C	1,2	1,0	1,2	1,1	1,2	1,0	1,1
Repeatability limit, $r$ (= 2,8 $s_r$ ), m°C	3,3	2,9	3,2	3,0	3,3	2,9	3,1
Coefficient of variation of repeatability, $CV(r)$ , %	0,23	0,21	0,22	0,21	0,22	0,19	0,21
Reproducibility standard deviation, $s_R$ , m°C	1,2	1,3	1,2	1,6	1,4	2,0	1,5
Reproducibility limit, $R$ (= 2,8 $s_R$ ), m°C	3,5	3,6	3,3	4,5	4,0	5,6	4,2
Coefficient of variation of reproducibility, $CV(R)$ , %	0,25	0,26	0,23	0,31	0,26	0,37	0,29

<sup>a</sup> The grand mean values are calculated by a weighted averaging of each of the sample values obtained. All other statistical means are calculated from the square root of the average of the squared deviations.

Table A.2 — Results for UHT whole milk

Sample	1	2	3	4	5	6	Grand mean <sup>a</sup>
No. participating labs after eliminating outliers	17	17	17	17	18	18	
Mean value, m°C	-491,6	-494,7	-512,6	-512,9	-534,8	-534,9	-513,6
Repeatability standard deviation, $s_r$ , m°C	1,2	1,7	2,0	1,1	1,4	1,2	1,5
Repeatability limit, $r$ (= 2,8 $s_r$ ), m°C	3,5	4,7	5,5	3,1	3,9	3,4	4,1
Coefficient of variation of repeatability, $CV(r)$ , %	0,25	0,34	0,38	0,22	0,26	0,22	0,28
Reproducibility standard deviation, $s_R$ , m°C	2,0	2,3	2,7	1,5	2,0	2,3	2,2
Reproducibility limit, $R$ (= 2,8 $s_R$ ), m°C	5,6	6,4	7,7	4,2	5,6	6,4	6,1
Coefficient of variation of reproducibility, $CV(R)$ , %	0,41	0,46	0,53	0,29	0,38	0,43	0,42

<sup>a</sup> The grand mean values are calculated by a weighted averaging of each of the sample values obtained. All other statistical means are calculated from the square root of the average of the squared deviations.

Table A.3 — Results for raw milk

Sample	1	2	3	4	5	6	Grand mean <sup>a</sup>
No. participating labs after eliminating outliers	18	18	18	17	18	17	
Mean value, m°C	-496,2	-504,9	-518,3	-525,5	-540,0	-548,8	-522,3
Repeatability standard deviation, $s_r$ , m°C	1,4	1,3	1,3	1,4	1,3	1,1	1,3
Repeatability limit, $r$ (= 2,8 $s_r$ ), m°C	3,8	3,6	3,7	3,8	3,6	3,2	3,6
Coefficient of variation of repeatability, $CV(r)$ , %	0,28	0,25	0,26	0,26	0,24	0,21	0,25
Reproducibility standard deviation, $s_R$ , m°C	2,1	2,5	2,6	2,1	2,2	2,3	2,3
Reproducibility limit, $R$ (= 2,8 $s_R$ ), m°C	5,9	7,0	7,4	6,0	6,2	6,5	6,5
Coefficient of variation of reproducibility, $CV(R)$ , %	0,42	0,50	0,51	0,41	0,41	0,42	0,45

<sup>a</sup> The grand mean values are calculated by a weighted averaging of each of the sample values obtained. All other statistical means are calculated from the square root of the average of the squared deviations.



## Annex B (informative)

### Interlaboratory trial on raw ovine and caprine milk

#### B.1 General

After preliminary studies in 2003, two separate international collaborative tests on raw ovine and caprine milk involving 12 laboratories in 11 countries were carried out in 2004-02 and 2004-03, respectively (Reference [7]).

The test included six test samples for each species, dispatched in 12 blind duplicates, and was organized by A.I.A. Laboratorio Standard Latte, Maccarese-Rome (IT) and C.M.I.O. C.T. Laboratory, Nicosia (CY). The test samples were prepared and distributed by A.I.A. Laboratorio Standard Latte, which also performed the statistical analysis in accordance with ISO 5725-1 [3] and ISO 5725-2 [4] to give the precision data shown in Tables B.1 and B.2, respectively.

#### B.2 Test results

**Table B.1 — Results for raw ovine milk**

Sample	A	B	C	D	E	F	Grand mean <sup>a</sup>
No. participating labs after eliminating outliers	7	8	8	8	8	8	
Mean value, m°C	-533,2	-572,4	-516,5	-490,9	-584,1	-571,9	-544,8
Repeatability standard deviation, $s_r$ , m°C	1,6	2,5	0,8	1,7	1,9	3,3	2,1
Repeatability limit, $r$ (= 2,8 $s_r$ ), m°C	4,4	6,9	2,2	4,7	5,3	9,2	5,9
Coefficient of variation of repeatability, $CV(r)$ , %	0,83	1,20	0,43	0,96	0,90	1,61	1,08
Reproducibility standard deviation, $s_R$ , m°C	3,0	4,4	2,2	3,5	3,6	5,0	3,7
Reproducibility limit, $R$ (= 2,8 $s_R$ ), m°C	8,3	12,3	6,2	9,7	10,1	13,9	10,4
Coefficient of variation of reproducibility, $CV(R)$ , %	1,55	2,15	1,21	1,98	1,72	2,43	1,91
<sup>a</sup> The grand mean values are calculated by a weighted averaging of each of the sample values obtained. All other statistical means are calculated from the square root of the average of the squared deviations.							

Table B.2 — Results for raw caprine milk

Sample	A	B	C	D	E	F	Grand mean <sup>a</sup>
No. participating labs after eliminating outliers	8	8	8	8	8	8	
Mean value, m°C	-541,9	-572,5	-550,0	-553,6	-561,5	-596,5	-562,7
Repeatability standard deviation, $s_r$ , m°C	0,8	1,0	1,7	1,0	1,8	1,5	1,4
Repeatability limit, $r$ ( $= 2,8 s_r$ ), m°C	2,3	2,9	4,8	2,7	5,1	4,3	3,8
Coefficient of variation of repeatability, $CV(r)$ , %	0,43	0,50	0,88	0,49	0,91	0,72	0,68
Reproducibility standard deviation, $s_R$ , m°C	3,5	2,4	3,0	3,4	3,0	3,0	3,1
Reproducibility limit, $R$ ( $= 2,8 s_R$ ), m°C	9,7	6,7	8,5	9,6	8,5	8,3	8,6
Coefficient of variation of reproducibility, $CV(R)$ , %	1,78	1,16	1,54	1,73	1,51	1,39	1,52

<sup>a</sup> The grand mean values are calculated by a weighted averaging of each of the sample values obtained. All other statistical means are calculated from the square root of the average of the squared deviations.

## Annex C (informative)

### Guidelines for the application of routine thermistor cryoscope methods

#### C.1 Introduction

This International Standard describes the reference cryoscope method for the determination of the freezing point of milk. In practice, the application of other thermistor cryoscope methods may be attractive for reasons such as:

- a) achieving a shorter duration of test by applying an earlier moment of measurement cut-off;
- b) keeping instruments in operation for which a complete adaptation to the requirements of the reference method is not feasible.

Examples of methods and/or deviations in use are:

- 1) measurement cut-off at 30 s, 50 s, 60 s or 90 s after the onset of freezing;
- 2) measurement cut-off when the instrument read-out is constant within  $\pm 1$  m°C for 20 s (or other time limit);
- 3) working with instrument parts with deviating characteristics;
- 4) using other sample volumes;
- 5) applying other freezing temperatures.

When applying routine methods, a correction should be made on routine test results in order to obtain an average agreement with the outcome of reference thermistor cryoscope measurements. The correction value should be determined for the relevant circumstances. This annex provides guidelines for establishing correction values.

#### C.2 Prerequisites

The applied routine method should fulfil requirements such as:

- a) using the same test principle, i.e. a thermistor cryoscope method;
- b) achieving a discrimination of 1 m°C or better over the range  $-400$  m°C to  $-600$  m°C;
- c) having linearity with no error greater than 1 m°C within the range  $-400$  m°C to  $-600$  m°C;
- d) achieving a measurement cut-off not earlier than 30 s after the onset of freezing;
- e) having a repeatability not greater than that specified in 12.2.

### C.3 Determination of the correction value

#### C.3.1 General

Any correction necessary shall be determined through comparative measurements with the reference method and the routine method, using a sufficient number of representative samples of the milk under consideration.

#### C.3.2 Sample taking and treatment

For this purpose, collect test samples which are representative of the target population, i.e. covering the normal range in compositional variation and the range of freezing point values occurring for the type of sample under consideration. Take and treat the test samples according to Clauses 7 and 9.

#### C.3.3 Number of test samples

The minimum number of samples in the test,  $n$ , shall be such that a critical difference of 0,4 m°C is not exceeded. Calculate  $n$  by using the approximate equation:

$$n \approx \left( \frac{\sigma_d t_{0,95}}{CD} \right)^2$$

where

$\sigma_d$  is the standard deviation of differences between the methods for individual samples;

$t_{0,95}$  is the numerical value of the normal reduced distribution at its unilateral 95 % confidence interval level;

CD is the defined value for the critical difference.

EXAMPLE For  $\sigma_d = 3,0$  m°C,  $t_{0,95} = 1,645$  and  $CD = 0,4$  m°C,  $n \geq 152$  samples.

#### C.3.4 Calibration and calibration check

Analyse the sodium chloride standard solutions (5.3) with known freezing point values under the same conditions as for the test samples. Take care that the conditions are the same for both the reference and the routine method. Also use the same sodium chloride standard solutions in both methods.

#### C.3.5 Measurement of test samples

With routine methods, sodium chloride standard solutions (5.3) with a fungicidal or a fungistatic agent may be used. However, an addition should not have an effect larger than +1,0 m°C as compared to an unpreserved solution with the same sodium chloride concentration. If used, the agent shall be of analytical grade quality and its use shall not be subject to limitations imposed by environmental regulations. When using a preservative, lower the sodium chloride concentration slightly so as to keep exactly the same freezing point as for the unpreserved sodium chloride standard solution (see Table 1). Establish a proper expiration date based on validation studies.

Determine the freezing point of the test samples in duplicate with the reference method specified in this International Standard.

Determine the freezing point of the same set of test samples in duplicate with the routine method. Differences in environmental conditions between measurements made by the reference method and the routine method should be avoided.

### C.3.6 Calculation of the correction value

Correct each individual result by an amount corresponding to the difference between the freezing point of the control sample used (see 5.3) and the value determined in the nearest calibration check. Then calculate the mean freezing point values for the duplicate measurements obtained using the reference method. Similarly, obtain mean values for the routine method measurements.

Calculate the standard deviation,  $s$ , of the individual differences between the mean results obtained by both methods. Delete outliers, i.e. samples with a difference larger than  $3s$ . Then calculate the average difference between the results obtained by the two methods. Use that value, rounded to its second significant figure, as the correction value.

If, after the deletion of outliers,  $s$  is still greater than  $3,0\text{ m}^\circ\text{C}$ , working with a correction value is considered to be too inaccurate and therefore unacceptable.

An example with reduced sample set ( $n = 10$ ) is shown in Table C.1.

Table C.1 — Example

Sample	Results with reference method (1)					Results with routine method (2)					Diff. (2) – (1)
	Raw data		After correction			Raw data		After correction			
	1	2	1	2	Mean	1	2	1	2	Mean	
512 control sample	-512,4	-513,0	—	—	—	-511,5	-512,7	—	—	—	—
1	-517,5	-518,2	-516,8	-517,5	-517,15	-518,1	-519,2	-518,0	-519,1	-518,55	-1,40
2	-538,1	-536,9	-537,4	-536,2	-536,80	-537,3	-539,0	-537,2	-538,9	-538,05	-1,25
3	-521,8	-521,3	-521,1	-520,6	-520,85	-522,9	-521,8	-522,8	-521,7	-522,25	-1,40
4	-528,6	-529,9	-527,9	-529,2	-528,55	-530,3	-531,4	-530,2	-531,3	-530,75	-2,20
5	-522,3	-520,9	-521,6	-520,2	-520,90	-527,3	-529,2	-527,2	-529,1	-528,15	-7,25 <sup>a</sup>
6	-515,7	-518,1	-514,9	-517,3	-516,10	-517,7	-518,9	-518,1	-519,3	-518,70	-2,60
7	-523,4	-522,1	-522,6	-521,3	-521,95	-525,2	-524,7	-525,6	-525,1	-525,35	-3,40
8	-512,2	-513,8	-511,4	-513,0	-512,20	-514,1	-513,4	-514,5	-513,8	-514,15	-1,95
9	-516,1	-514,2	-515,3	-513,4	-514,35	-517,5	-518,2	-517,9	-518,6	-518,25	-3,90
10	-521,6	-522,3	-520,8	-521,5	-521,15	-521,4	-523,4	-521,8	-523,8	-522,80	-1,65
512 control sample	-513,1	-512,5	—	—	—	-511,7	-511,5	—	—	—	—
Average difference											-2,7
Standard deviation, $s$											1,73
Average difference after deleting outlier sample data											-2,2
Value of $s$ after deleting outlier sample data											0,88
<sup>a</sup> Outlier.											

The average difference between the results when measuring with the routine method and the reference method in this example is  $-2,2\text{ m}^\circ\text{C}$ . This is also the correction value needed when measuring with the routine method. In this case, it means a correction to a warmer temperature.

### C.4 Validity

The calculated correction value is valid for the specific combination of type of test sample and routine method attributes, i.e. instrument properties, moment of measurement cut-off, test portion volume and freezing temperature.

## Annex D (informative)

### Adjustment of the freezing point value used as the reference for genuine milk

This annex was first introduced into ISO 5764 | IDF 108:2002, for reasons explained hereafter.

To estimate whether or not a sample of milk contains extraneous water, it is necessary to compare the freezing point of that test sample with the freezing point of “genuine milk”, i.e. milk known to be free from extraneous water.

For many samples (e.g. processed milk made from a mixture of many different farm supplies) it is not always possible to obtain a reference value for genuine milk. In such cases, it is necessary to set an average target value for genuine milk. Some countries have arrived at a freezing point value for genuine milk after completing extensive surveys. Others have adopted a value based on many years of historic observations.

A shift in the freezing point temperature scale is likely to occur when changing from the method exercised so far to the reference method described in this International Standard. This change in the temperature scale is, in part, due to more vigorous standardization of instrument components and characteristics and in part to the redefinition of the “cut-off” point on the freezing point curve of milk (see Clause C.1).

Clearly, this change in scale gives rise to a change in freezing point readings from those recorded previously. This makes it necessary to apply a small change to historic values used for genuine milk. If an adjustment were not made, a systematic error would apply to the assessment of extraneous water in milk.

It is recommended, therefore, to adjust “once only” the value applied to genuine milk to bring it in line with the new scale in this International Standard. Such an adjustment should be made by, or established under the supervision of, each national authority.

The adjustment may be made following the procedure given in Annex C with the following additional precautions being taken:

- a) seek the guidance of a statistician in order to establish the optimum number of samples required in the comparison in order to keep any residual systematic error to an acceptably low level;
- b) use test samples in the trial representing as closely as possible the type of milk being tested routinely;
- c) test one set of samples in the trial by closely following this reference cryoscope standard method;
- d) test a duplicate set of samples by using the test method and the instrument characteristics used when the historic reference value for “genuine milk” was established;
- e) keep a record of this study for future reference.

## Bibliography

- [1] ISO 707|IDF 50, *Milk and milk products — Guidance on sampling*
- [2] ISO 1042, *Laboratory glassware — One-mark volumetric flasks*
- [3] ISO 5725-1, *Accuracy (trueness and precision) of measurement methods and results — Part 1: General principles and definitions*
- [4] ISO 5725-2, *Accuracy (trueness and precision) of measurement methods and results — Part 2: Basic method for the determination of repeatability and reproducibility of a standard measurement method*
- [5] INTERNATIONAL DAIRY FEDERATION. Measurement of extraneous water by determination of freezing point of milk. *Bull. IDF*, 1983, (154), pp. 1-43
- [6] INTERNATIONAL DAIRY FEDERATION. Reference materials and interlaboratory collaborative studies. *Bull. IDF*, 1986, (207), pp. 1-207
- [7] INTERNATIONAL DAIRY FEDERATION. Collaborative studies organized to include sheep and goat milk in the scope of joint standard ISO 5764|IDF 108:2002, *Milk — Determination of freezing point — Thermistor cryoscope method (Reference method)*. *Bull. IDF*, 2007, (419), pp. 1-15

**ISO 5764:2009(E)**  
**IDF 108:2009(E)**

---

---

**ICS 67.100.10**

Price based on 17 pages