

INTERNATIONAL STANDARD

ISO 5749

Third edition
2004-09-15

Pliers and nippers — Diagonal cutting nippers — Dimensions and test values

*Pinces et tenailles — Pinces coupantes diagonales — Dimensions et
valeurs d'essai*



Reference number
ISO 5749:2004(E)

© ISO 2004

PDF disclaimer

This PDF file may contain embedded typefaces. In accordance with Adobe's licensing policy, this file may be printed or viewed but shall not be edited unless the typefaces which are embedded are licensed to and installed on the computer performing the editing. In downloading this file, parties accept therein the responsibility of not infringing Adobe's licensing policy. The ISO Central Secretariat accepts no liability in this area.

Adobe is a trademark of Adobe Systems Incorporated.

Details of the software products used to create this PDF file can be found in the General Info relative to the file; the PDF-creation parameters were optimized for printing. Every care has been taken to ensure that the file is suitable for use by ISO member bodies. In the unlikely event that a problem relating to it is found, please inform the Central Secretariat at the address given below.

© ISO 2004

All rights reserved. Unless otherwise specified, no part of this publication may be reproduced or utilized in any form or by any means, electronic or mechanical, including photocopying and microfilm, without permission in writing from either ISO at the address below or ISO's member body in the country of the requester.

ISO copyright office
Case postale 56 • CH-1211 Geneva 20
Tel. + 41 22 749 01 11
Fax + 41 22 749 09 47
E-mail copyright@iso.org
Web www.iso.org

Published in Switzerland

Foreword

ISO (the International Organization for Standardization) is a worldwide federation of national standards bodies (ISO member bodies). The work of preparing International Standards is normally carried out through ISO technical committees. Each member body interested in a subject for which a technical committee has been established has the right to be represented on that committee. International organizations, governmental and non-governmental, in liaison with ISO, also take part in the work. ISO collaborates closely with the International Electrotechnical Commission (IEC) on all matters of electrotechnical standardization.

International Standards are drafted in accordance with the rules given in the ISO/IEC Directives, Part 2.

The main task of technical committees is to prepare International Standards. Draft International Standards adopted by the technical committees are circulated to the member bodies for voting. Publication as an International Standard requires approval by at least 75 % of the member bodies casting a vote.

Attention is drawn to the possibility that some of the elements of this document may be the subject of patent rights. ISO shall not be held responsible for identifying any or all such patent rights.

ISO 5749 was prepared by Technical Committee ISO/TC 29, *Small tools*, Subcommittee SC 10, *Assembly tools for screws and nuts, pliers and nippers*.

This third edition cancels and replaces the second edition (ISO 5749:1988) which has been technically revised.

.....

Pliers and nippers — Diagonal cutting nippers — Dimensions and test values

1 Scope

This International Standard specifies the principal dimensions of diagonal cutting nippers and the test values for the nippers in order to verify their aptitude to function in conformity with ISO 5744. General technical requirements are given in ISO 5743.

The diagonal cutting nippers illustrated in this International Standard are examples only and are not intended to affect the manufacturer's design.

2 Normative references

The following referenced documents are indispensable for the application of this document. For dated references, only the edition cited applies. For undated references, the latest edition of the referenced document (including any amendments) applies.

ISO 5743, *Pliers and nippers — General technical requirements*

ISO 5744:2004, *Pliers and nippers — Methods of test*

3 Dimensions and test values

3.1 Diagonal cutting nippers for hard wire

The main dimensions for cutting nippers for hard wire are shown in Figure 1 and given in Table 1.

The cutting nippers shall be tested in accordance with ISO 5744.

After the load test, the permanent set s shall not exceed the value given in Table 2. If distance l_1 is not suitable for the load test, the formula given in ISO 5744:2004, 4.2 shall be used.

The cutting force, F_1 , and the diameter, d , of the test wire shall not exceed the values given in Table 2.

Nippers having a lever ratio differing from the values given in Table 2 shall be checked for compliance using the formula given in ISO 5744:2004, 5.3.3.

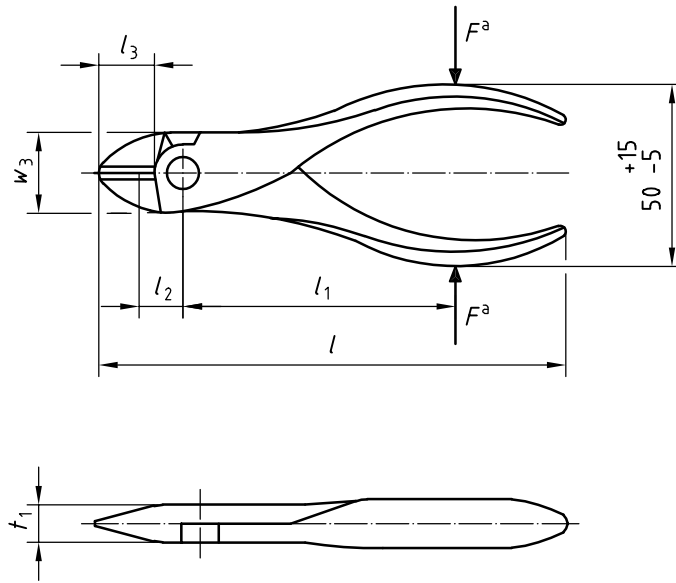

a F = Load applied in load test or F_1 force applied in cutting test.

Figure 1 — Diagonal cutting nippers for hard wire

Table 1 — Diagonal cutting nippers for hard wire, main dimensions

Dimensions in millimetres

l	l_3 max.	w_3 max.	t_1 max.
125 ± 6	18	22	10
140 ± 7	20	25	11
160 ± 8	22	28	12
180 ± 9	25	32	14
200 ± 10	28	36	16

Table 2 — Diagonal cutting nippers for hard wire, force application and test values

Nominal length l mm	l_1 mm	l_2 mm	Cutting test		Load test	
			Diameter of hard test wire d^a mm	Maximum cutting force $F_{1 \text{ max}}$ N	Load F N	Maximum permanent set s_{max}^b mm
125	80	10	1,25	500	800	0,5
140	90	11	1,4	575	900	1
160	100	12,5	1,6	700	1 000	1
180	112	14	1,8	850	1 120	1
200	125	16	2	1 020	1 250	1

a Data for hard test wire are given in ISO 5744.

b $s = w_1 - w_2$ (see ISO 5744).

3.2 Diagonal cutting nippers for medium hard wire

The main dimensions for cutting nippers for hard wire are shown in Figure 2 and given in Table 3.

The cutting nippers shall be tested in accordance with ISO 5744.

After the load test, the permanent set s shall not exceed the value given in Table 4. If distance l_1 is not suitable for the load test, the formula given in ISO 5744:2004, 4.2 shall be used.

The cutting force, F_1 , and the diameter, d , of the test wire shall not exceed the values given in Table 4.

Nippers having a lever ratio differing from the values given in Table 4 shall be checked for compliance using the formula given in ISO 5744:2004, 5.3.2.

Dimensions in millimetres

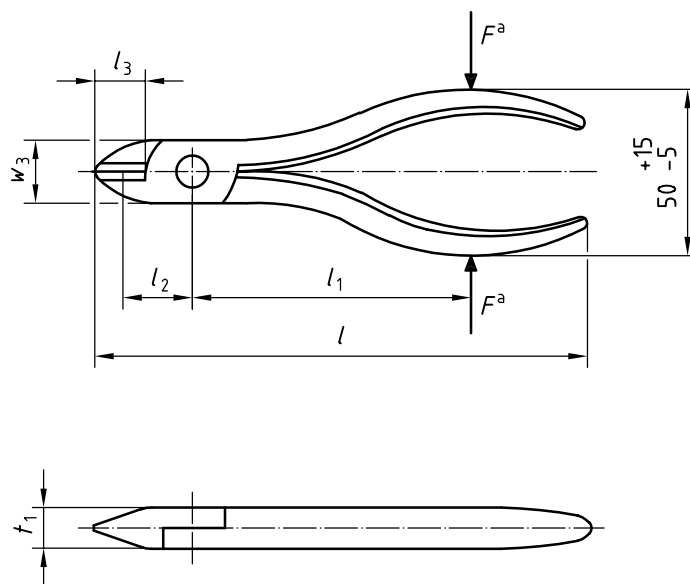

^a F = Load applied in load test or F_1 force applied in cutting test.

Figure 2 — Diagonal cutting nippers for medium hard wire

Table 3 — Diagonal cutting nippers for medium hard wire, main dimensions

Dimensions in millimetres

l	l_3 max.	w_3 max.	t_1 max.
125 ± 6	18	22	10
140 ± 7	20	25	11
160 ± 8	22	28	12
180 ± 9	25	32	14
200 ± 10	28	36	16

Table 4 — Diagonal cutting nippers for medium hard wire, force application and test values

Nominal length	l_1	l_2	Cutting test		Load test	
			Diameter of medium hard test wire	Maximum cutting force	Load	Maximum permanent set
l mm	mm	mm	d^a mm	$F_{1\max}$ N	F N	s_{\max}^b mm
125	80	12,5	1,6	450	800	0,5
140	90	14	1,6	450	900	1
160	100	16	1,6	460	1 000	1
180	112	18	1,6	460	1 120	1
200	125	20	1,6	460	1 250	1

^a Data for medium hard test wire are given in ISO 5744.

^b $s = w_1 - w_2$ (see ISO 5744).

3.3 Toggle lever assisted side cutting nippers for hard wire

The main dimensions for cutting nippers for hard wire are shown in Figure 3 and given in Table 5.

The cutting nippers shall be tested in accordance with ISO 5744.

After the load test, the permanent set s shall not exceed the value given in Table 6. If distance l_1 is not suitable for the load test, the formula given in ISO 5744:2004, 4.2 shall be used.

The cutting force, F_1 , and the diameter, d , of the test wire shall not exceed the values given in Table 6.

Nippers having a lever ratio differing from the values given in Table 6 shall be checked for compliance using the formula given in ISO 5744:2004, 5.3.4.



Dimensions in millimetres

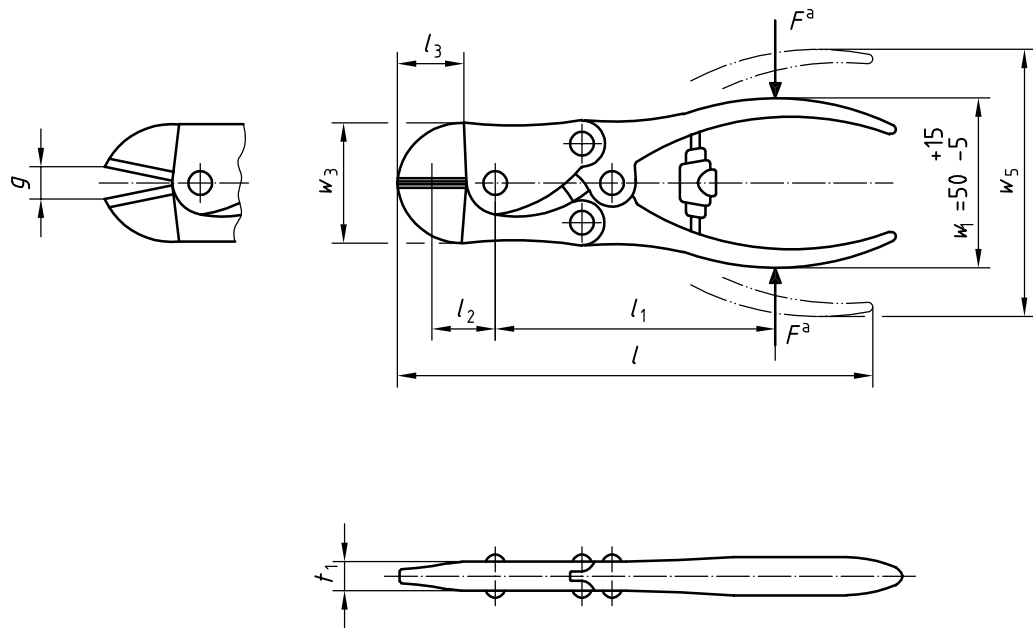

a F = Load applied in load test or F_1 force applied in cutting test.

Figure 3 — Toggle lever assisted side cutting nippers for hard wire

Table 5 — Toggle lever assisted side cutting nippers for hard wire, main dimensions

Dimensions in millimetres

l	l_3 max.	w_3 max.	g min.	l_1 max.
200 ± 10	25	45	5	18
224 ± 11	28	48	6	18

Table 6 — Toggle lever assisted side cutting nippers for hard wire, force application and test values

Nominal length	l	l_1	l_2	Cutting test		Load test		
				Lever ratio ^a	Diameter of hard test wire d^b	Maximum cutting force $F_{1 \max}$	Load F	Maximum permanent set s_{\max}^c
	mm	mm	mm		mm	N	mm	
200	140	18		14,5	2,5	690	840	1
224	160	20		16,5	2,5	790	950	1

a The lever ratio is equal to $(w_5 - w_1)/g$.

b Data for hard test wire are given in ISO 5744.

c $s = w_1 - w_2$ (see ISO 5744).

4 Designation

EXAMPLE 1 Diagonal cutting nippers, number 101 in accordance with ISO 5742, with a nominal length of 140 mm and for hard wire (H) are designated as follows:

Diagonal cutting nippers 101 - ISO 5749 - 140 - H

EXAMPLE 2 Diagonal cutting nippers, number 101 in accordance with ISO 5742, with a nominal length of 160 mm and for medium wire (M) are designated as follows:

Diagonal cutting nippers 101 - ISO 5749 - 160 - M

EXAMPLE 3 Toggle lever assisted side cutting nippers, number 105 in accordance with ISO 5742, with a nominal length of 200 mm are designated as follows:

Toggle lever assisted side cutting nippers 105 - ISO 5749 - 200

5 Marking

Marking shall be in accordance with ISO 5743.

Bibliography

- [1] ISO 5742, *Pliers and nippers — Nomenclature*

www.iso.org

ICS 25.140.30

Price based on 7 pages