

INTERNATIONAL STANDARD

ISO 5744

Third edition
2004-09-15

Pliers and nippers — Methods of test

Pinces et tenailles — Méthodes d'essai



Reference number
ISO 5744:2004(E)

© ISO 2004

PDF disclaimer

This PDF file may contain embedded typefaces. In accordance with Adobe's licensing policy, this file may be printed or viewed but shall not be edited unless the typefaces which are embedded are licensed to and installed on the computer performing the editing. In downloading this file, parties accept therein the responsibility of not infringing Adobe's licensing policy. The ISO Central Secretariat accepts no liability in this area.

Adobe is a trademark of Adobe Systems Incorporated.

Details of the software products used to create this PDF file can be found in the General Info relative to the file; the PDF-creation parameters were optimized for printing. Every care has been taken to ensure that the file is suitable for use by ISO member bodies. In the unlikely event that a problem relating to it is found, please inform the Central Secretariat at the address given below.

© ISO 2004

All rights reserved. Unless otherwise specified, no part of this publication may be reproduced or utilized in any form or by any means, electronic or mechanical, including photocopying and microfilm, without permission in writing from either ISO at the address below or ISO's member body in the country of the requester.

ISO copyright office
Case postale 56 • CH-1211 Geneva 20
Tel. + 41 22 749 01 11
Fax + 41 22 749 09 47
E-mail copyright@iso.org
Web www.iso.org

Published in Switzerland

Contents

Page

Foreword	iv
1 Scope	1
2 Normative references	1
3 General	1
4 Load test	1
4.1 General	1
4.2 Pliers and nippers	1
4.3 Lever-assisted pliers	2
4.4 Test piece	2
5 Wire cutting test	5
5.1 Verification of test wire	5
5.2 Cutting force	5
5.3 Cutting test	6
6 Torsion test	8
6.1 General	8
6.2 Test piece	8
7 Soft wire cutting test	10
8 Hardness of gripping surfaces	11
Bibliography	12

Foreword

ISO (the International Organization for Standardization) is a worldwide federation of national standards bodies (ISO member bodies). The work of preparing International Standards is normally carried out through ISO technical committees. Each member body interested in a subject for which a technical committee has been established has the right to be represented on that committee. International organizations, governmental and non-governmental, in liaison with ISO, also take part in the work. ISO collaborates closely with the International Electrotechnical Commission (IEC) on all matters of electrotechnical standardization.

International Standards are drafted in accordance with the rules given in the ISO/IEC Directives, Part 2.

The main task of technical committees is to prepare International Standards. Draft International Standards adopted by the technical committees are circulated to the member bodies for voting. Publication as an International Standard requires approval by at least 75 % of the member bodies casting a vote.

Attention is drawn to the possibility that some of the elements of this document may be the subject of patent rights. ISO shall not be held responsible for identifying any or all such patent rights.

ISO 5744 was prepared by Technical Committee ISO/TC 29, *Small tools*, Subcommittee SC 10, *Assembly tools for screws and nuts, pliers and nippers*.

This third edition cancels and replaces the second edition (ISO 5744:1988) which has been technically revised.

.....

Pliers and nippers — Methods of test

1 Scope

This International Standard specifies methods of test for checking the correct functioning of pliers and nippers.

The test parameters have been specified on the basis of the functional uses of the tools.

2 Normative references

The following referenced documents are indispensable for the application of this document. For dated references, only the edition cited applies. For undated references, the latest edition of the referenced document (including any amendments) applies.

EN 12166:1988, *Copper and copper alloys — Wire for general purposes*

IEC 60317-0-1, *Specifications for particular types of winding wires — Part 0-1: General requirements — Enamelled round copper wire*

3 General

Unless otherwise specified, values like dimensions used for positioning a test piece, test forces and locations for applying test forces have a tolerance of $\pm 2,5$ %.

4 Load test

4.1 General

The test shall be carried out using suitable equipment which can be checked by comparison with a standard.

All tests shall be executed on the same tested tool and in the sequence of tests specified in this International Standard.

4.2 Pliers and nippers

For the type and size of tool, given in the dimensional standards, define a point for the application of the load on the handles at distance l_1 from the centre of the joint rivet, and insert a suitable test piece into the jaws (see 4.4).

If a pair of pliers is fitted with a comfort grip, the test shall preferably be carried out with the comfort grip removed.

Apply a load of 50 N and measure the width, w_1 , of the handles. Increase the load to the specified value, F , as given in the tables of the applicable product standard, and then reduce it to 50 N. The load F shall be applied four times and then the width, w_2 of the handles shall again be measured at the same distance l_1 .

ISO 5744:2004(E)

The difference between the first and second readings shall not exceed the maximum value of permanent set ($s = w_1 - w_2$), see Figures 1, 2, 3 and 4, appropriate to the type and size of tool.

After the test, the tool shall show no deformation that can affect its use.

If the load test cannot conveniently be carried out at distance l_1 from the centre of the joint rivet, then a more suitable position for the load may be chosen at distance l'_1 from the centre of the joint rivet. The load F' at distance l'_1 from the centre of the joint rivet shall then be calculated from the formula

$$F' = \frac{F \times l_1}{l'_1}$$

where

F is the load at distance l_1 (see Figures 1, 2 and 3);

F' is the calculated load at distance l'_1 ;

l_1 is the distance from the centre of the joint rivet to the point of application of the load given in the applicable product standard;

l'_1 is the measured distance from the centre of the joint rivet to the point of application of the load.

After the load test, the permanent set, s , shall not exceed the value given in the applicable product standard.

4.3 Lever-assisted pliers

For the type and size of tool, given in the dimensional standards, define a point for the application of the load on the handles at distance l_1 from the centre of the joint rivet, and insert a suitable test piece into the jaws (see 4.4).

Apply a load of $0,5 \times F$; reduce it to 50 N and measure the width, w_1 , of the handles. Increase the load to the specified value F , and then reduce it to 50 N. The load F shall be applied four times and then the width, w_2 , of the handles shall again be measured at the same distance l_1 .

The difference between the first and second readings shall not exceed the maximum value of permanent set ($s = w_1 - w_2$), see Figures 1, 2 and 3, appropriate to the type and size of tool.

After the test, the tool shall show no deformation that can affect its use.

4.4 Test piece

The test piece shall have a hardness value of 30 HRC to 40 HRC and be of such a size and profile as to make contact with the jaws over a length of $8 \text{ mm} \pm 1 \text{ mm}$ from the point of the jaws.

For end cutting nippers the test piece shall make contact over the full length of the jaws. With the test piece inserted, the gap between the points of the jaws shall be $3 \text{ mm} \pm 1 \text{ mm}$.

For multiple slip joint pliers and slip joint pliers the contact between the jaws and the test piece shall extend over lengths of $6 \text{ mm} \pm 1 \text{ mm}$.

Dimensions in millimetres

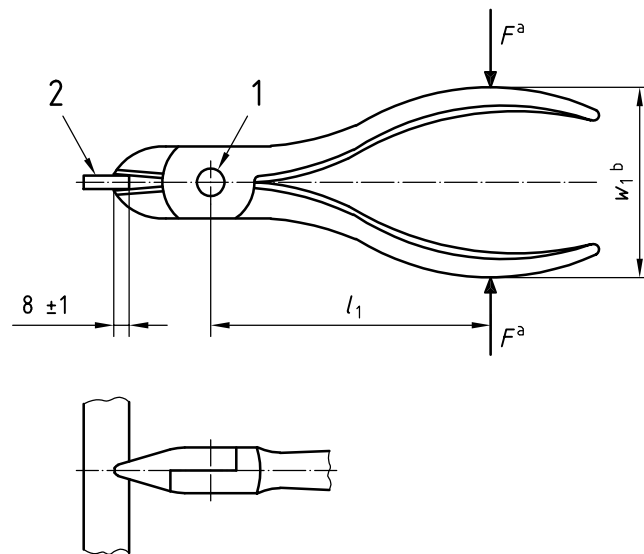

Key

- 1 joint rivet
- 2 test piece

^a F = load applied in load test or F_1 = force applied in cutting test.

^b or w_2 measured in accordance with 4.2.

Figure 1 — Diagonal cutting nippers

Dimensions in millimetres

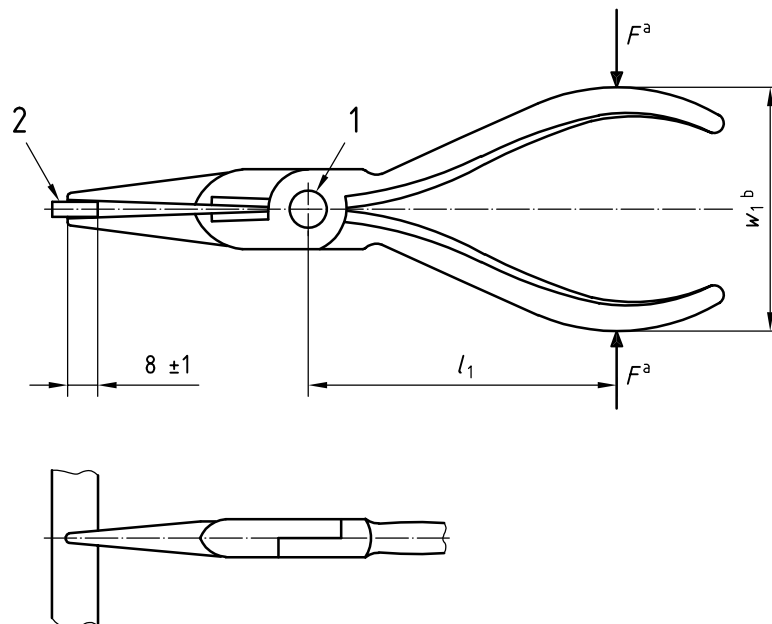

Key

- 1 joint bolt
- 2 test piece

^a F = load applied in load test or F_1 = force applied in cutting test.

^b or w_2 measured in accordance with 4.2.

Figure 2 — Snipe nose, flat nose and round nose pliers

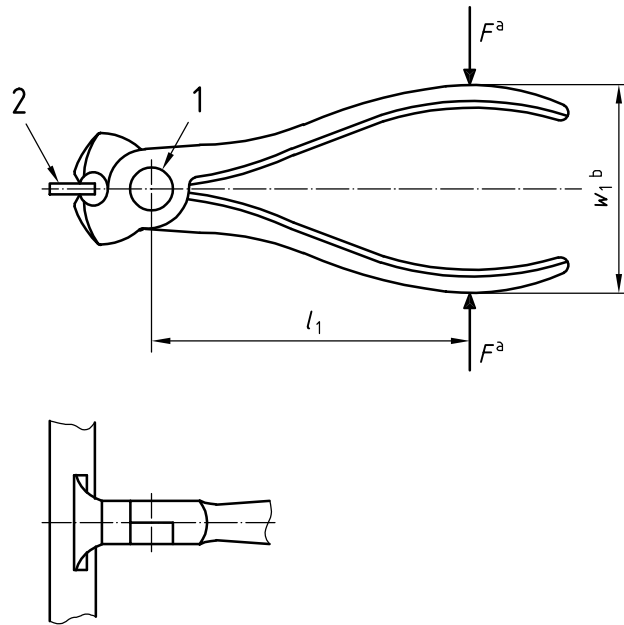

Key

- 1 joint rivet
- 2 test piece
- a $F =$ load applied in load test or $F_1 =$ force applied in cutting test.
- b or w_2 measured in accordance with 4.2.

Figure 3 — End cutting nippers

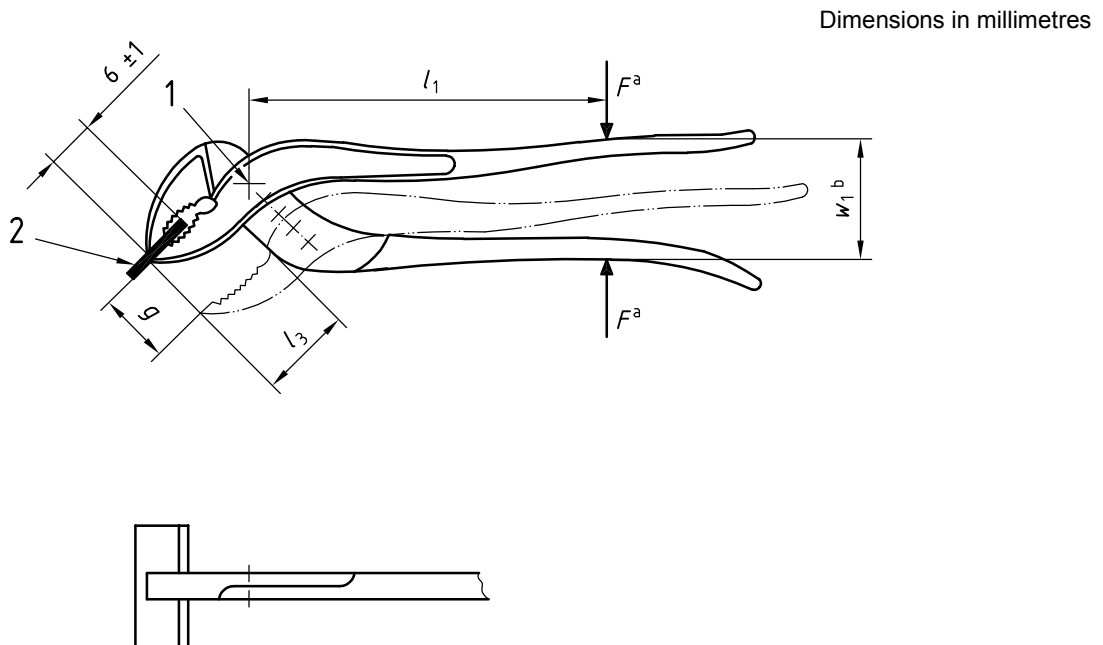

Key

- 1 joint bolt
- 2 test piece
- a $F =$ load applied in load test.
- b or w_2 measured in accordance with 4.2.

Figure 4 — Multiple slip joint pliers

5 Wire cutting test

5.1 Verification of test wire

The wire to be used for cutting tests shall first be verified using equipment that can be checked by comparison with a standard.

Assemble in the test equipment two tungsten carbide cutters, with edges ground to an inclusive angle of $60^\circ \pm 1^\circ$ having a radius of $0,3 \text{ mm} \pm 0,02 \text{ mm}$, with the cutting edges parallel to each other and at right angles to the test wire (see Figure 5).

Record the force required to cut the wire. The mean of three readings shall correspond to the values given in Tables 1 and 2.

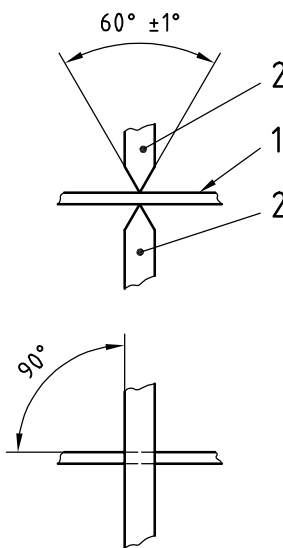

Key

- 1 test wire
- 2 carbide cutter

Figure 5 — Test equipment

5.2 Cutting force

The cutting force values are given in Tables 1 and 2.

Table 1 — Medium hard test wire

Nominal wire diameter <i>d</i> mm	Approximate tensile strength ^a MPa	Cutting force <i>F</i> ₂ N
1,6	1 600	1 800 ± 90
^a The tensile strength is given for guidance only.		

Table 2 — Hard test wire

Nominal wire diameter <i>d</i> mm	Approximate tensile strength ^a MPa	Cutting force <i>F</i> ₂ N
1,25	2 300	2 000 ± 100
1,4	2 250	2 350 ± 125
1,6	2 200	2 800 ± 150
1,8	2 150	3 400 ± 175
2	2 100	4 000 ± 200
2,5	2 000	5 700 ± 300

^a The tensile strength is given for guidance only.

5.3 Cutting test

5.3.1 General

Calibrated test wire shall be used and the tool shall be placed in test equipment that can be checked by comparison with a standard.

Insert the test wire into the jaws of the tool and apply the force F_1 to the handles at the points defined by l_1 and l_2 according to the size and type of tool. For end cutting nippers, the test shall be carried out at a distance of 3 mm from the extremity of the cutting edge.

NOTE l_2 is the distance from the centre of the rivet to the location of the centre of the wire. It is given in each product standard.

If the wire cutting test cannot conveniently be carried out at the points defined by l_1 and l_2 then more suitable positions may be chosen defined by l'_1 and l'_2 .

5.3.2 Medium hard test wire

In this case the cutting force F'_1 shall be calculated using the formula

$$F'_1 = \frac{F_2 \times 1,6 \times l'_2}{l'_1}$$

where

F'_1 is the maximum calculated cutting force not given in the applicable product standards;

F_2 is the cutting force according to Table 1;

1,6 is the correction factor for medium hard test wire;

l'_1 is the measured distance from the centre of the joint rivet to the point of application of the load;

l'_2 is the measured distance from the centre of the joint rivet to the location of the test wire.

NOTE Lever ratio is equal to l_1/l_2 .

Measure the force, F'_1 , necessary to cut the test wire, which shall not exceed the value of the maximum cutting force $F'_{1\max}$ given for the type and size of tool.

Upon completion of the test, the cutting edges shall show neither visible indentation nor distortion that would affect the cutting performance of the tool. Nor shall the tool show any damage that can affect its use.

After this test, a soft wire cutting test shall be completed in accordance with Clause 7.

5.3.3 Hard test wire

In this case the cutting force F'_1 shall be calculated using the formula

$$F'_1 = \frac{F_2 \times 2 \times l'_2}{l'_1}$$

where

F'_1 is the maximum calculated cutting force not given in the applicable product standards;

F_2 is the cutting force according to Table 2;

2 is the correction factor for hard test wire;

l'_1 is the measured distance from the centre of the joint rivet to the point of application of the load;

l'_2 is the measured distance from the centre of the joint rivet to the location of the test wire.

NOTE Lever ratio is equal to l_1/l_2 .

Measure the force F'_1 necessary to cut the test wire, which shall not exceed the value of the maximum cutting force $F'_{1\max}$ given for the type and size of tool.

Upon completion of the test, the cutting edges shall show neither visible indentation nor distortion that would affect the cutting performance of the tool. Nor shall the tool show any damage that can affect its use.

After this test, a soft wire cutting test shall be completed in accordance with Clause 7.

5.3.4 Hard test wire (toggle lever assisted nippers)

In this case the cutting force F'_1 shall be calculated using the formula

$$F'_1 = \frac{F_2 \times 2 \times g}{w_5 - w_1}$$

where

F'_1 is the maximum calculated cutting force not given in the applicable product standards;

F_2 is the cutting force according to Table 2;

2 is the correction factor for hard test wire;

g is the measured opening of the jaws;

w_1 is the measured width of the handles at the closed position;

w_5 is the measured width of the handles at the open position.

ISO 5744:2004(E)

Measure the force F'_1 necessary to cut the test wire, which shall not exceed the value of the maximum cutting force $F'_{1\max}$ given for the type and size of tool.

Upon completion of the test, the cutting edges shall show neither visible indentation nor distortion that would affect the cutting performance of the tool. Nor shall the tool show any damage that can affect its use.

After this test, a soft wire cutting test shall be completed in accordance with Clause 7.

6 Torsion test

6.1 General

The tool to be tested shall be placed in equipment that can be checked by comparison with a standard.

Depending on the type and size of tool, insert the point of the jaws into a suitable test piece in accordance with 6.2. Apply a handle load equal to 50 % of the load test specified in an applicable standard at a distance l_1 from the centre of the joint rivet then clamp the handles to resist the turning moment.

Apply the torque, T , in both clockwise and anti-clockwise directions. The angular movement, α , shall not exceed the value given for the type and size of tool.

Any loosening of the joint or permanent set of the jaws resulting from the test shall not impair the efficient functioning of the tool.

6.2 Test piece

For flat nose pliers the test piece shall be $3\text{ mm} \pm 0,1\text{ mm}$ thick, $12\text{ mm} \pm 1\text{ mm}$ wide and shall have a hardness of 45 HRC to 50 HRC. The test piece shall be inserted between the jaws of the pliers to a depth of $6\text{ mm} \pm 1\text{ mm}$ (see Figure 6).

For round nose pliers, the points of the jaws shall be supported in a test piece with two holes. The holes shall be $4\text{ mm} \pm 0,1\text{ mm}$ in diameter, $3\text{ mm} \pm 0,1\text{ mm}$ deep with flat bottoms, spaced on the centre line to give a dimension of $4\text{ mm} \pm 0,1\text{ mm}$ between the inner edges. The test piece shall have a hardness of 45 HRC to 50 HRC (see Figure 7).

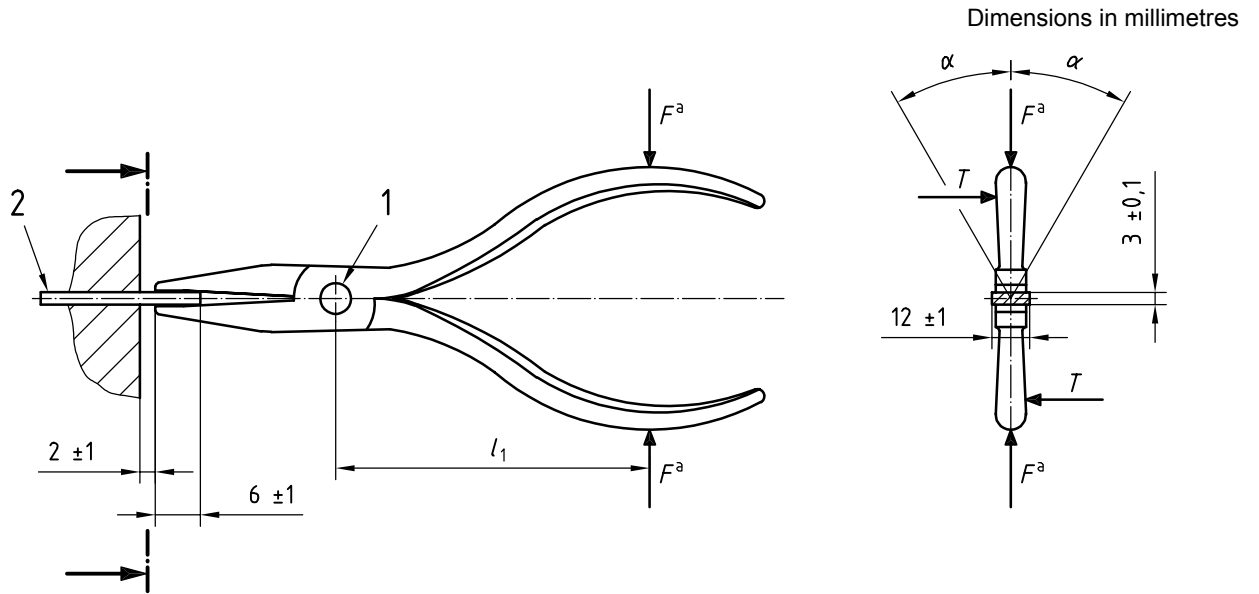

Key

- 1 joint rivet
- 2 test piece

a F = Load applied in torsion test (see 6.1).

Figure 6 — Flat nose pliers

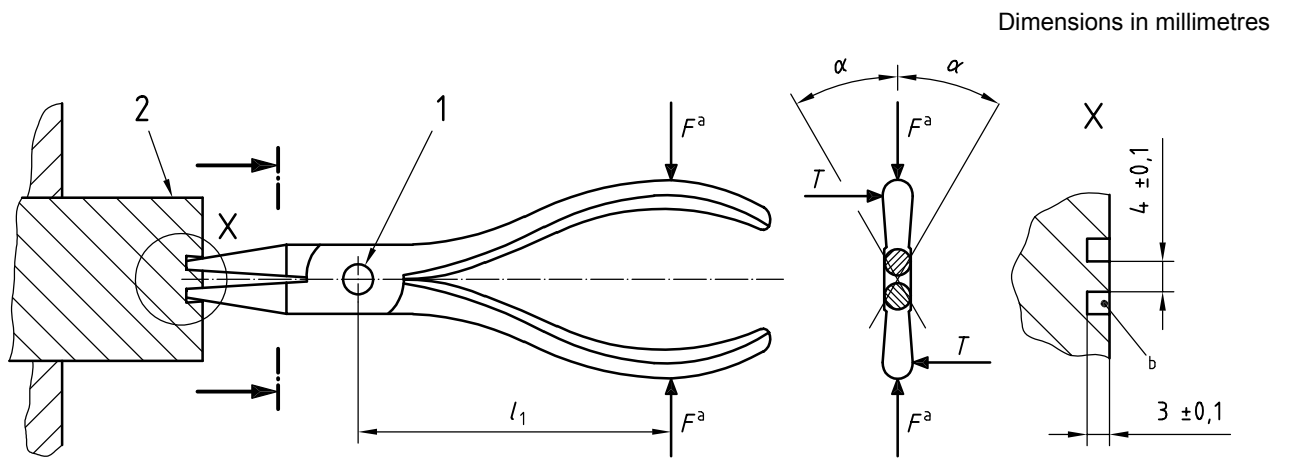

Key

- 1 joint rivet
- 2 test piece

a F = Load applied in torsion test (see 6.1).

b Two holes $\varnothing 4 \pm 0,1$.

Figure 7 — Round nose pliers

7 Soft wire cutting test

On completion of the hard wire or the medium hard wire cutting test, pliers and nippers shall be capable of cutting soft wires as follows:

- a) **Diagonal cutting nippers**
Cut the test wire over a length of at least two thirds of the total cutting edge as measured from the point of the jaw.
- b) **End cutting nippers and engineer's pliers (combined pliers)**
Cut test wire over the whole length of the cutting edge.

Position the test wire between the jaws of the pliers according to the examples shown in Figures 8, 9 and 10.

Completely cut off test wires, as specified in Table 3, without them being exposed to stress, caused by bending or pulling, which could facilitate the cutting operation.

Place a piece of the test wire of maximum length 25 mm between the cutting edges of the pliers. This piece of wire shall be supported only by the jaws of the pliers and shall be cut only by manual pressure on the handles.

Table 3 — Materials and diameters of soft test wires

Type of pliers and nippers, and corresponding International Standard	Wire material and corresponding standard	Tensile strength	Nominal wire diameter
		MPa	<i>d</i> mm
Diagonal cutting nippers for hard wire ISO 5749	Bronze ^a	560 to 670	1,5
Diagonal cutting nippers for medium hard wire ISO 5749	Copper ^b	—	0,5
End cutting nippers for hard wire ISO 5748	Bronze ^a	560 to 670	1,5
End cutting nippers for medium hard wire ISO 5748	Copper ^b	—	0,5
Snipe nose pliers with side cutter for medium hard wire ISO 5745	Bronze ^a	560 to 670	1
Engineer's or lineman's pliers ISO 5746	Bronze ^a	560 to 670	1
^a Wire according to EN 12166:1998, material designation CW452K, material condition R560. ^b Wire according to IEC 60317-0-1.			

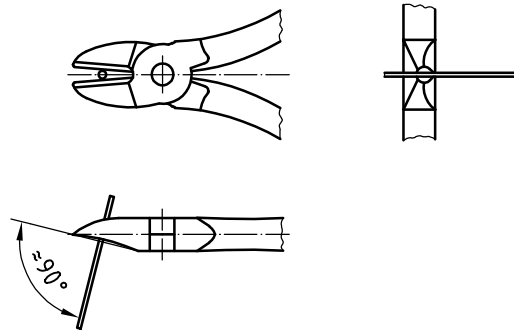

Figure 8 — Diagonal cutting nippers

Dimensions in millimetres

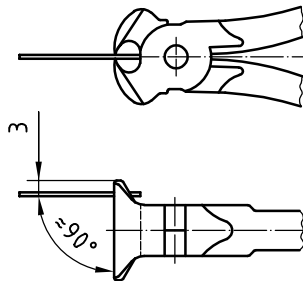

Figure 9 — End cutting nippers

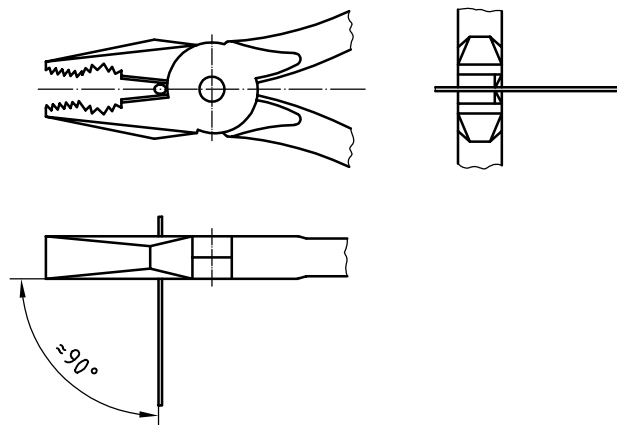

Figure 10 — Combined gripping and cutting pliers
e.g. engineer's pliers or lineman's pliers

8 Hardness of gripping surfaces

The hardness shall be measured on the gripping surface or on an adjacent face at a distance of not more than 1 mm from the gripping surface.

Bibliography

- [1] ISO 5742, *Pliers and nippers — Nomenclature*
- [2] ISO 5743, *Pliers and nippers — General technical requirements*
- [3] ISO 5745, *Pliers and nippers — Pliers for gripping and manipulating — Dimensions and test values*
- [4] ISO 5746, *Pliers and nippers — Engineer's and lineman's pliers — Dimensions and test values*
- [5] ISO 5747, *Pliers and nippers — Lever assisted side cutting pliers, end and diagonal cutting nippers — Dimensions and test values*
- [6] ISO 5748, *Pliers and nippers — End cutting nippers — Dimensions and test values*
- [7] ISO 5749, *Pliers and nippers — Diagonal cutting nippers — Dimensions and test values*
- [8] ISO 8976, *Pliers and nippers — Multiple slip joint pliers — Dimensions and test values*
- [9] ISO 9242, *Pliers and nippers — Construction worker's pincers — Dimensions and test values*
- [10] ISO 9243, *Pliers and nippers — Carpenter's pincers — Dimensions and test values*
- [11] ISO 9343, *Pliers and nippers — Slip joint pliers — Dimensions and test values*

1

ICS 25.140.30

Price based on 12 pages