**Tractors for agriculture and
forestry — Roll-over protective
structures — Static test method and
acceptance conditions**

*Tracteurs agricoles et forestiers — Structures de protection contre le
retournement — Méthode d'essai statique et conditions d'acceptation*





COPYRIGHT PROTECTED DOCUMENT

© ISO 2013

All rights reserved. Unless otherwise specified, no part of this publication may be reproduced or utilized otherwise in any form or by any means, electronic or mechanical, including photocopying, or posting on the internet or an intranet, without prior written permission. Permission can be requested from either ISO at the address below or ISO's member body in the country of the requester.

ISO copyright office
Case postale 56 • CH-1211 Geneva 20
Tel. + 41 22 749 01 11
Fax + 41 22 749 09 47
E-mail copyright@iso.org
Web www.iso.org

Published in Switzerland

Contents

| | Page |
|--|-----------|
| Foreword | iv |
| Introduction | v |
| 1 Scope | 1 |
| 2 Normative references | 1 |
| 3 Terms and definitions | 1 |
| 4 Symbols and abbreviated terms | 4 |
| 5 Apparatus | 4 |
| 5.1 Horizontal loading tests..... | 4 |
| 5.2 Crushing tests..... | 8 |
| 6 Preparation of tractor and ROPS for testing | 9 |
| 7 Test procedures | 10 |
| 7.1 Sequence of tests..... | 10 |
| 7.2 Horizontal loading from rear, front and side..... | 11 |
| 7.3 Crushing tests..... | 15 |
| 7.4 Second longitudinal loading..... | 18 |
| 8 Determination of seat index point (SIP), seat location and adjustment for test | 18 |
| 8.1 Seat index point..... | 18 |
| 8.2 Seat location and adjustment for test..... | 18 |
| 9 Clearance zone | 19 |
| 9.1 Determination of the clearance zone..... | 19 |
| 9.2 Determination of the clearance zone for tractors with a non-reversible seat..... | 20 |
| 9.3 Determination of the clearance zone for tractors with a reversible driver's position..... | 21 |
| 9.4 Optional seats..... | 22 |
| 10 Tolerances | 22 |
| 11 Acceptance conditions | 23 |
| 11.1 General..... | 23 |
| 11.2 Clearance zone..... | 23 |
| 11.3 Recording permanent deflection..... | 23 |
| 11.4 Required force..... | 23 |
| 11.5 Overload test..... | 23 |
| 11.6 Additional conditions..... | 25 |
| 11.7 Cold weather embrittlement..... | 25 |
| 12 Seatbelt anchorage performance | 26 |
| 13 Labelling | 26 |
| 14 Extension to other tractor models | 26 |
| 14.1 Administrative extension..... | 26 |
| 14.2 Technical extension..... | 26 |
| 15 Test report | 27 |
| Annex A (normative) Optional requirements for providing resistance to brittle fracture of roll-over protective structure at reduced operating temperature | 28 |
| Annex B (normative) Test report for roll-over protective structure | 30 |
| Annex C (informative) Designation of Maintenance Agency | 36 |
| Bibliography | 37 |

Foreword

ISO (the International Organization for Standardization) is a worldwide federation of national standards bodies (ISO member bodies). The work of preparing International Standards is normally carried out through ISO technical committees. Each member body interested in a subject for which a technical committee has been established has the right to be represented on that committee. International organizations, governmental and non-governmental, in liaison with ISO, also take part in the work. ISO collaborates closely with the International Electrotechnical Commission (IEC) on all matters of electrotechnical standardization.

The procedures used to develop this document and those intended for its further maintenance are described in the ISO/IEC Directives, Part 1. In particular the different approval criteria needed for the different types of ISO documents should be noted. This document was drafted in accordance with the editorial rules of the ISO/IEC Directives, Part 2. www.iso.org/directives

Attention is drawn to the possibility that some of the elements of this document may be the subject of patent rights. ISO shall not be held responsible for identifying any or all such patent rights. Details of any patent rights identified during the development of the document will be in the Introduction and/or on the ISO list of patent declarations received. www.iso.org/patents

Any trade name used in this document is information given for the convenience of users and does not constitute an endorsement.

The committee responsible for this document is ISO/TC 23, *Agriculture and forestry machinery*, Subcommittee SC 2, *Common tests*.

This fifth edition cancels and replaces the fourth edition (ISO 5700:2006), which has been technically revised for the technical harmonization with OECD Code 4: July 2012.

Introduction

Testing of roll-over protective structures (ROPS) for wheeled or tracked tractors for agriculture and forestry aims at avoiding or limiting risks to the driver resulting from accidental overturning during normal operation (e.g. field work) of the tractor. The strength of the ROPS is tested by applying static loads and a static crushing test to simulate actual loads which can be imposed on the cab or frame when the tractor overturns either to the rear or to the side without free fall. The tests allow observations to be made on the strength of the structure and the attachment brackets to the tractor and also of the tractor parts that could be affected by the load imposed on the structure.

Provision is made to cover both tractors with the conventional forward-facing driver's position only, as well as those with a reversible driver's position. For tractors with a reversible driver's position, a clearance zone is defined to be the combined clearance zones for the two driving positions. The point of application of the side loading is determined as the mid-point between the seat index points measured in the two positions.

It is recognized that there could be tractor designs — for example, lawn-mowers, narrow vineyard tractors, low profile tractors used in low buildings with limited overhead clearance, orchards, etc., stilt tractors and certain forestry machines such as forwarders — for which this International Standard is not appropriate.

This International Standard specifies technical performance requirements, associated test procedures and performance test report information. Technical harmonization with OECD is ensured by the Maintenance Agency operating as specified in [Annex C](#).

NOTE For narrow-track wheeled tractors, see ISO 12003-1^[6] and ISO 12003-2.^[7]

Tractors for agriculture and forestry — Roll-over protective structures — Static test method and acceptance conditions

1 Scope

This International Standard specifies a static test method and the acceptance conditions for roll-over protective structures (cab or frame) of wheeled or tracked tractors for agriculture and forestry.

It is applicable to tractors having at least two axles for wheels mounted with pneumatic tyres, or having tracks instead of wheels, with an unballasted tractor mass of not less than 600 kg and a minimum track width of the rear wheels greater than 1 150 mm. It is not applicable to tractors having a mass ratio (maximum permissible mass / reference mass) greater than 1,75.

2 Normative references

The following referenced documents are indispensable for the application of this document. For dated references, only the edition cited applies. For undated references, the latest edition of the referenced document (including any amendments) applies.

ISO 630-1:2011, *Structural steels — Part 1: General technical delivery conditions for hot-rolled products*

ISO 5353:1995, *Earth-moving machinery, and tractors and machinery for agriculture and forestry — Seat index point*

ASTM A370, *Standard Test Methods and Definitions for Mechanical Testing of Steel Products*

3 Terms and definitions

For the purposes of this document, the following terms and definitions apply.

3.1

roll-over protective structure

ROPS

framework (safety cab or frame) protecting drivers of tractors for agricultural and forestry that avoids or limits risk to the driver resulting from accidental overturning during normal operation

Note 1 to entry: The ROPS is characterized by the provision of space for a clearance zone, as defined in 9.1, either inside the envelope of the structure or within a space bounded by a series of straight lines from the outer edges of the structure to any part of the tractor that might come into contact with flat ground and that is capable of supporting the tractor in that position if the tractor overturns.

3.2

unballasted tractor mass

mass of the tractor in working order with tanks and radiators full, roll-over protective structure with cladding, and any track equipment or additional front-wheel drive components required for normal use

Note 1 to entry: Not included are the operator, optional ballast weights, additional wheel equipment, special equipment and loads.

3.3
reference mass

m_t
mass, not less than the unballasted mass, selected by the manufacturer for calculation of the energy inputs and crushing forces to be used in the tests

Note 1 to entry: The reference mass shall not be less than the unballasted mass and must be sufficient to ensure the mass ratio does not exceed 1,75.

3.4
maximum permissible mass
technically permissible mass

maximum allowable equipment mass and allowable payload specified by the manufacturer

Note 1 to entry: This mass corresponds to the sum of the technically maximum possible axle loads.

3.5
mass ratio

number calculated by taking the maximum permissible mass divided by reference mass

3.6
horizontal loading test

application of a horizontal load to the rear, front and side of the roll-over protective structure

3.7
crushing test

application of a vertical load through a beam placed laterally across the uppermost members of the roll-over protective structure

3.8
longitudinal median plane

longitudinal plane of symmetry

zero Y plane

vertical plane Y passing through the mid-points of AB, perpendicular to AB, A and B being such that

- for each wheel, the vertical plane passing through its axis cuts the mid-plane of the wheel following a straight line Δ which meets the supporting surface of the vehicle at one point, and
- A and B are two points thus defined which correspond to two wheels, both of which are either steering or powered wheels, situated respectively at the two ends of the same real or imaginary axle

See [Figure 1](#).

Note 1 to entry: The mid-plane of the dual wheels being equidistant from the inner edge of one wheel and the outer edge of the other, the straight line Δ is, in this particular case, the intersection of the mid-plane of the dual wheels and the vertical plane passing through the axis of the axle pin.

Note 2 to entry: Adapted from ISO 612:1978, Clause 5.

Note 3 to entry: The longitudinal median plane may also be applied to track-laying tractors.

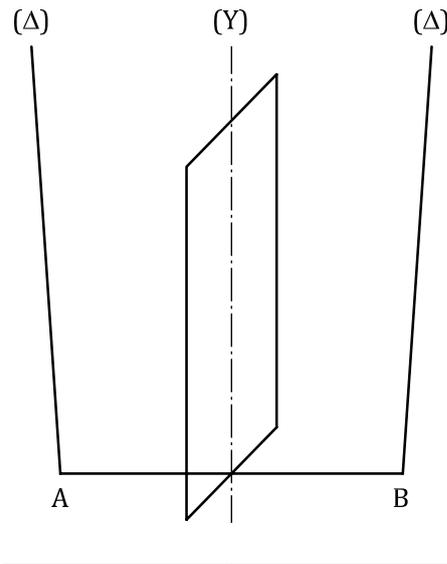

Figure 1 — Longitudinal median plane

3.9

track width

distance between the median planes of the wheels or tracks

Note 1 to entry: If A and B are the two points thus defined for the wheels on the same axle of the tractor, then the track width is the distance between points A and B. The track may be defined for both front and rear wheels.

Note 2 to entry: Where there are dual wheels, the track width is the distance between two planes, each of which is the median plane of the pairs of wheels.

Note 3 to entry: For track-laying tractors, the track width is the distance between the median planes of the tracks.

3.10

vertical reference plane

plane established before any application of loading, generally longitudinal to the tractor, passing through the seat index point (SIP) and the steering-wheel centre and which is used for establishing the resultant load point in crush loading tests

Note 1 to entry: When a steering wheel does not exist, a vertical plane passing through the SIP and parallel to the longitudinal median plane of the tractor is used. Normally, the reference plane coincides with the longitudinal median plane of the tractor.

3.11

seat reference plane

vertical plane generally longitudinal to the tractor, passing through the seat index point and to the steering wheel centre and which is used for establishing the clearance zone

Note 1 to entry: This plane is established at the beginning of the series of tests and normally coincides with the longitudinal median plane of the tractor. This plane is assumed to move horizontally with the seat and steering wheel during loading but to remain perpendicular to the tractor or the floor of the ROPS if the latter is resiliently mounted. When a steering wheel does not exist, a vertical plane passing through the SIP and parallel to the longitudinal median plane of the tractor is used.

3.12

wheelbase

distance between the vertical planes passing through the two lines AB, as defined in 3.8, one for the front wheels and one for the rear wheels

3.13

agricultural tractor

self-propelled agricultural vehicle having at least two axles, or a track-laying agricultural vehicle, and having a maximum design speed of not less than 6 km/h, particularly designed to pull, push, carry and operate implements used for agricultural work (including forestry work), which may be provided with a detachable loading platform

Note 1 to entry: It may be equipped with one or more seats.

4 Symbols and abbreviated terms

For the purposes of this document, the symbols in [Table 1](#) apply.

Table 1 — Symbols

| Symbol | Description | Unit |
|-----------|---|------|
| a_h | Half of the horizontal seat adjustment | mm |
| a_v | Half of the vertical seat adjustment | mm |
| D | Deflection of the ROPS for the calculated basic energy required at the point of, and in line with, the load application | mm |
| D' | Deflection of the protective structure for the calculated energy required | mm |
| E_{il1} | Energy input to be absorbed during first longitudinal loading | J |
| E_{il2} | Energy input to be absorbed during second longitudinal loading | J |
| E_{is} | Energy input to be absorbed during side loading | J |
| F | Static load force for the basic energy required | N |
| F_{max} | Maximum static load force occurring during loading (excluding overload) | N |
| F' | Force for the calculated energy required | N |
| F_f | Applied force at front in the crushing test | N |
| F_r | Applied force at rear in the crushing test | N |
| m_t | Reference mass | kg |
| W | Width of the ROPS | mm |

5 Apparatus

5.1 Horizontal loading tests

5.1.1 Material, equipment and attachment means for ensuring that the tractor chassis is firmly fixed to the ground and supported independently of the tyres.

5.1.2 Means of applying a horizontal force to the roll-over protective structure, such as are shown in [Figures 2, 3 and 4](#), complying with the requirements of [5.1.2.1](#) to [5.1.2.4](#).

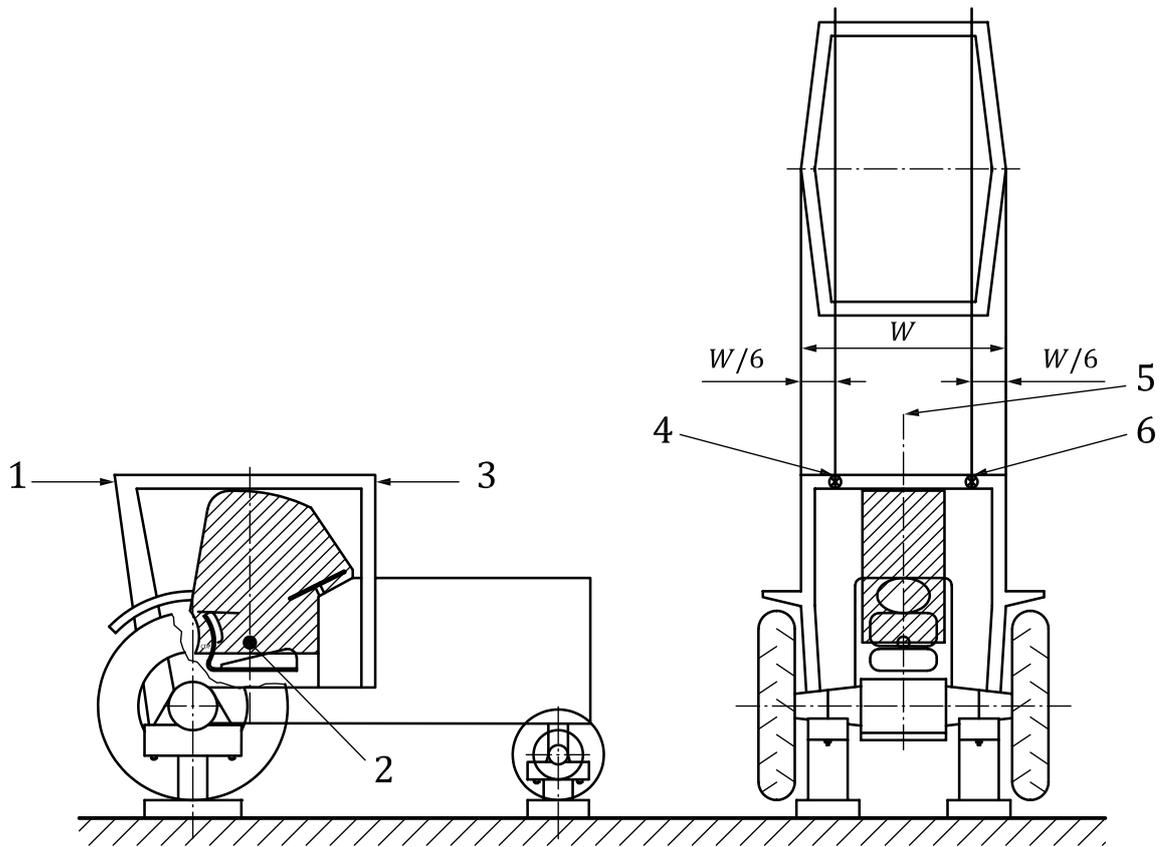

Key

- 1 rear load
- 2 seat index point
- 3 front load
- 4 second longitudinal load, front or rear
- 5 seat reference plane, longitudinal median plane
- 6 longitudinal load, rear or front

Figure 2 — Front and rear load application

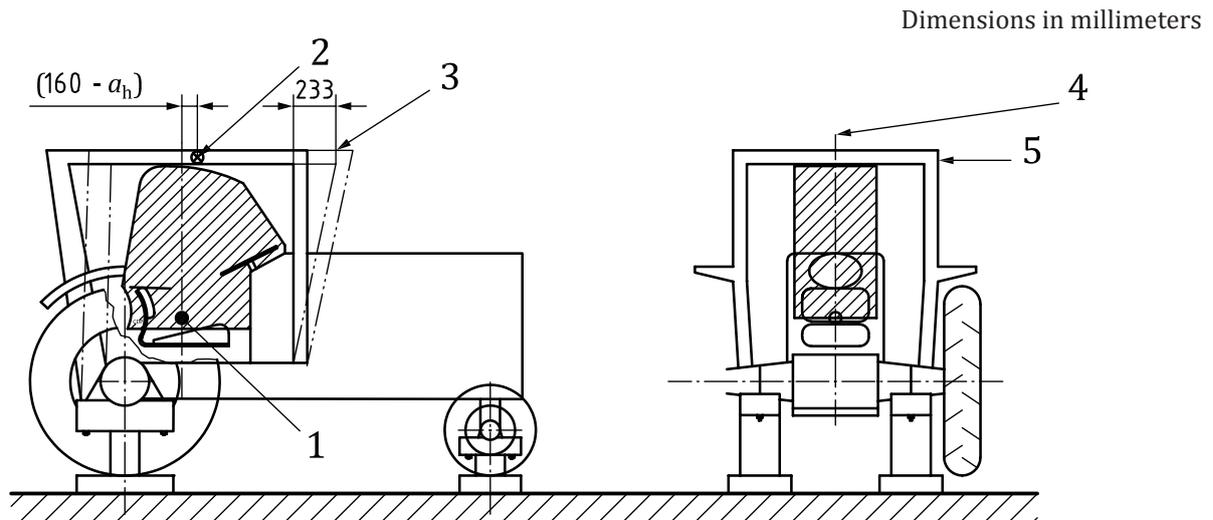

Key

- 1 seat index point
- 2 point of side load application (see 7.2.3)
- 3 deflection due to rear longitudinal loading
- 4 seat reference plane, longitudinal median plane
- 5 load

Figure 3 — Side load application: Protective cab

Dimensions in millimeters

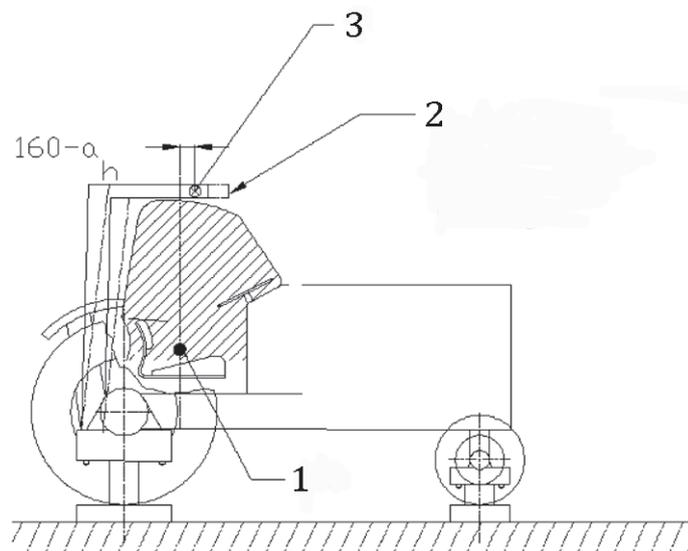

Key

- 1 seat index point
- 2 deflection due to rear longitudinal loading
- 3 point of side load application (see 7.2.3)

Figure 4 — Side load application: Rear roll bar frame

5.1.2.1 It shall be ensured that the load can be uniformly distributed normal to the direction of loading and along a beam of length between 250 mm and 700 mm, in an exact multiple of 50 mm.

5.1.2.2 The edges of the beam in contact with the roll-over protective structure shall be curved with a maximum radius of 50 mm.

5.1.2.3 Universal joints, or the equivalent, shall be incorporated to ensure that the loading device does not constrain the structure in rotation or translation in any direction other than the loading direction.

5.1.2.4 Where the roll-over protective structure's length, covered by the appropriate load-applying beam, does not constitute a straight line normal to the load application direction, the space shall be packed so as to distribute the load over this length.

5.1.3 Equipment for measuring force and deflection along the direction of application of the force and relative to the tractor chassis. To ensure accuracy, measurements shall be taken as continuous recordings. The measuring devices shall be located so as to record the force and deflection at the point of, and along the line of, loading.

5.1.4 Means of proving that the clearance zone has not been entered during the test. A measuring rig based on the clearance zone as shown in [Figure 5](#) may be used. The dimensions are given in [Table 2](#).

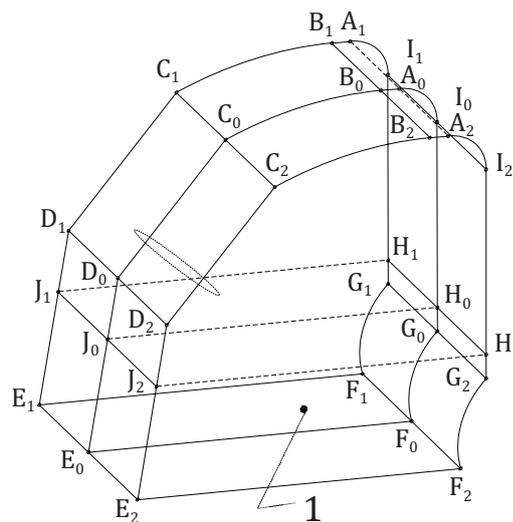

Key

1 seat index point

Figure 5 — Clearance zone measuring rig

Table 2 — Dimensions for the Clearance zone measuring rig shown in [Figure 5](#)

| Dimensions | | Remarks |
|--|-----|---|
| | mm | |
| $\left. \begin{matrix} A_1A_0 \\ B_1B_0 \end{matrix} \right\}$ | 100 | Minimum |
| $\left. \begin{matrix} A_1A_2 \\ B_1B_2 \\ C_1C_2 \end{matrix} \right\}$ | 500 | |
| $\left. \begin{matrix} D_1D_2 \\ E_1E_2 \end{matrix} \right\}$ | 500 | $\left\{ \begin{matrix} \text{Minimum or equal to the} \\ \text{steering-wheel radius plus 40 mm,} \\ \text{whichever is greater} \end{matrix} \right.$ |
| $\left. \begin{matrix} F_1F_2 \\ G_1G_2 \\ H_1H_2 \\ I_1I_2 \\ J_1J_2 \end{matrix} \right\}$ | 500 | |
| $\left. \begin{matrix} E_1E_0 \\ E_1E_2 \end{matrix} \right\}$ | 250 | $\left\{ \begin{matrix} \text{Minimum or equal to the} \\ \text{steering-wheel radius plus 40 mm,} \\ \text{whichever is greater} \end{matrix} \right.$ |
| J_0E_0 | 300 | |
| F_0G_0 | — | $\left. \begin{matrix} \\ \\ \\ \end{matrix} \right\}$ Depending on the tractor |
| I_0G_0 | — | |
| C_0D_0 | — | |
| E_0F_0 | — | |
| Note For other dimensions, see Figure 13 . | | |

5.2 Crushing tests

5.2.1 Material, equipment and attachment means for ensuring that the tractor chassis is firmly fixed to the ground (and supported) independently of the tyres.

5.2.2 Means of applying a downwards force on the roll-over protective structure, such as that shown in [Figure 6](#), including a stiff beam with a width of 250 mm.

5.2.3 Means of proving that the clearance zone has not been entered during the test. A measuring rig based on the clearance zone as shown in [Figure 5](#) may be used.

5.2.4 Equipment for measuring the total vertical force applied.

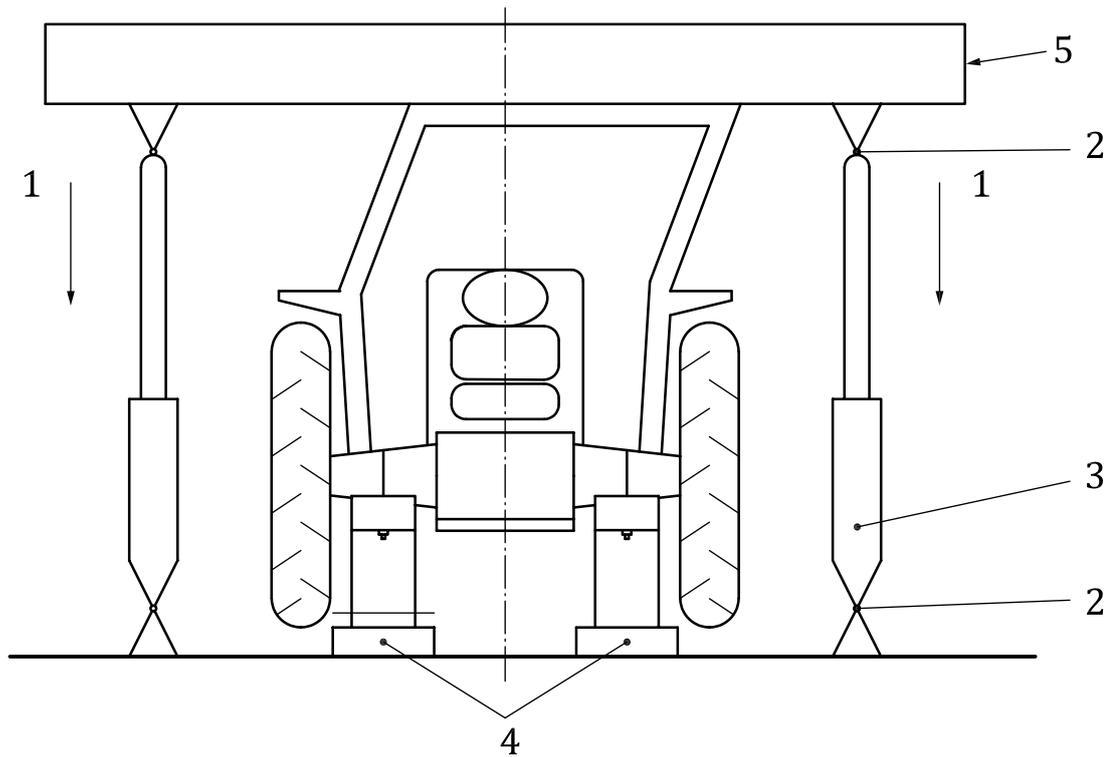

Key

- 1 force
- 2 universal pin joints
- 3 hydraulic cylinder
- 4 supports under front and rear axles
- 5 crushing beam

Figure 6 — Example of arrangement for crushing test

6 Preparation of tractor and ROPS for testing

6.1 The protective structure may be manufactured either by the tractor manufacturer or by an independent firm. In either case, a test is only valid for the model of tractor on which it is carried out.

6.2 The protective structure shall be retested for each model of tractor to which it is to be fitted. However, testing stations may certify that the strength tests are also valid for tractor models derived from the original model by modifications to the engine, transmission and steering and front suspension. On the other hand, more than one protective structure may be tested for any one model of tractor.

NOTE See [Clause 14](#) for extension to other tractor models.

6.3 The roll-over protective structure shall be manufactured to production specifications and shall be fitted to the appropriate tractor model chassis in accordance with the manufacturer's declared attachment method to form the assembly.

6.4 This assembly shall be secured to the bedplate so that the members connecting the assembly and the bedplate do not deflect significantly in relation to the ROPS under loading. The assembly shall not receive any support under loading other than that due to the initial attachment.

6.5 A track width setting for the rear wheels, if present, shall be chosen such that there is no interference with the ROPS during testing.

6.6 The assembly shall be supported and secured or modified so that all the test energy is absorbed by the roll-over protective structure and its attachment to the tractor rigid components.

6.7 Deflection of the chassis integral components is permissible during the ROPS test. Any members that absorb energy during the ROPS test should be noted in the test report.

6.8 All windows, panels and removable non-structural fittings shall be removed so that they do not contribute to the strength of the ROPS.

In cases where it is possible to fix doors and windows open or remove them during work, they shall be either removed or fixed open for the test, so that they do not add to the strength of the ROPS. It shall be noted whether, in this position, they would create a hazard for the driver in the event of overturning.

6.9 Any component of the tractor contributing to the strength of the protective structure, such as mudguards, which has been reinforced by the manufacturer, should be described and its measurements given in the test report.

6.10 Where a “tandem” tractor (e.g. articulated tractor) is concerned, the mass of the standard version of that part to which the ROPS is fitted shall be used.

6.11 The ROPS shall be instrumented with the necessary equipment to obtain the required force-deflection data.

7 Test procedures

CAUTION — Take adequate protection to protect personnel during tests. Some of the tests specified in this international standard involve the use of processes which could lead to a hazardous situation.

7.1 Sequence of tests

7.1.1 The test shall be carried out in accordance with the procedures given in [7.1.1.1](#) to [7.1.1.5](#) in the sequence as given.

7.1.1.1 First longitudinal loading

For a tractor with at least 50 % of its tractor mass on the rear wheels and for track-laying tractors, the longitudinal loading shall be applied from the rear. For other tractors the longitudinal loading shall be applied from the front.

7.1.1.2 First crushing test

The first crushing test shall be applied at the same end of the ROPS as the longitudinal loading.

7.1.1.3 Loading from the side

In the case of an offset seat and/or non-symmetrical strength of the ROPS, the side loading shall be on the side most likely to lead to entering of the clearance zone.

7.1.1.4 Second crushing test

The second crushing test shall be applied at the opposite end of the ROPS to the longitudinal loading. In the case of two-post designs, it may be at the same point as in [7.1.1.2](#).

7.1.1.5 Second longitudinal loading

A second longitudinal loading shall be applied to tractors fitted with a ROPS designed to be folded/tilted when the longitudinal loading in [7.1.1.1](#) has not been applied in the direction in which the ROPS is designed to fold/tilt. The second longitudinal loading does not apply to tiltable ROPS where the tilt mechanism is independent from the structural integrity of the ROPS.

NOTE A folding ROPS (Example: two posts) is designed to be folded temporarily for special operating conditions. A tiltable ROPS (Example: non-two posts) is designed to tilt for service.

7.1.2 All tests shall be performed on the same ROPS. No repairs or straightening of any member shall be carried out between any parts of the tests.

7.1.3 On completion of all tests, permanent deflections of the ROPS shall be measured and recorded.

As loading continues, the cab/frame deformation may cause the direction of loading to change. This is permissible.

7.2 Horizontal loading from rear, front and side

7.2.1 General requirements for horizontal loading tests

7.2.1.1 The loads applied to the ROPS shall be distributed by means of a stiff beam, complying with the requirements of [5.1.2](#), located normal to the direction of load application; the stiff beam may have a means of preventing its being displaced sideways. The rate of load application shall be such that the rate of deflection does not exceed 5 mm/s. As the load is applied, *F* and *D* shall be recorded simultaneously as continuous recordings to ensure accuracy. Once the initial application has commenced, the load shall not be reduced until the test has been completed; but it is permissible to cease increasing the load if desired, for example, to record measurements.

7.2.1.2 The direction of the applied force shall be within the following limits:

- at start of test (no load), $\pm 2^\circ$;
- during test (under load), 10° above and 20° below the horizontal.

7.2.1.3 If no structural cross-member exists at the application point, a substitute test beam which does not add strength to the structure may be used to complete the test procedure.

7.2.2 First longitudinal loading

7.2.2.1 The load shall be applied horizontally and parallel to the longitudinal median plane of the tractor from the rear or the front as required by [7.1.1.1](#). If from the rear, it shall be applied to the opposite side to that to which the side load is applied. If from the front, it shall be to the same side as the side load.

7.2.2.2 The load shall be applied to the uppermost transverse structural member of the ROPS (i.e. that part which would be likely to strike the ground first in an overturning accident).

7.2.2.3 The load application point shall be at one-sixth of the width of the roll-over protective structure's top, inwards from the outside corner. The width of the ROPS shall be taken as the distance between two

lines parallel to the longitudinal median plane of the tractor and touching the outside extremities of the ROPS in the horizontal plane touching the top of the uppermost transverse structural members.

7.2.2.4 In the event that the ROPS is formed of curved members and no appropriate corners exist, the following general procedure shall apply for determining W . The test engineer shall identify the curved member most likely to first strike ground in the event of an asymmetrical rear or front overturn (e.g. an overturn to the front or rear where one side of the ROPS is likely to bear the initial loading). The end points of W shall be the mid-points of the external radii created between other straight or curved members which form the uppermost ROPS structure. In the event that multiple curved members could be selected, the test engineer shall establish ground lines for each possible member to determine which surface is most likely to strike ground first. See [Figures 7](#) and [8](#) for examples.

NOTE In the event of curved members, only the width at the end of the structure to which the longitudinal load is to be applied need be considered.

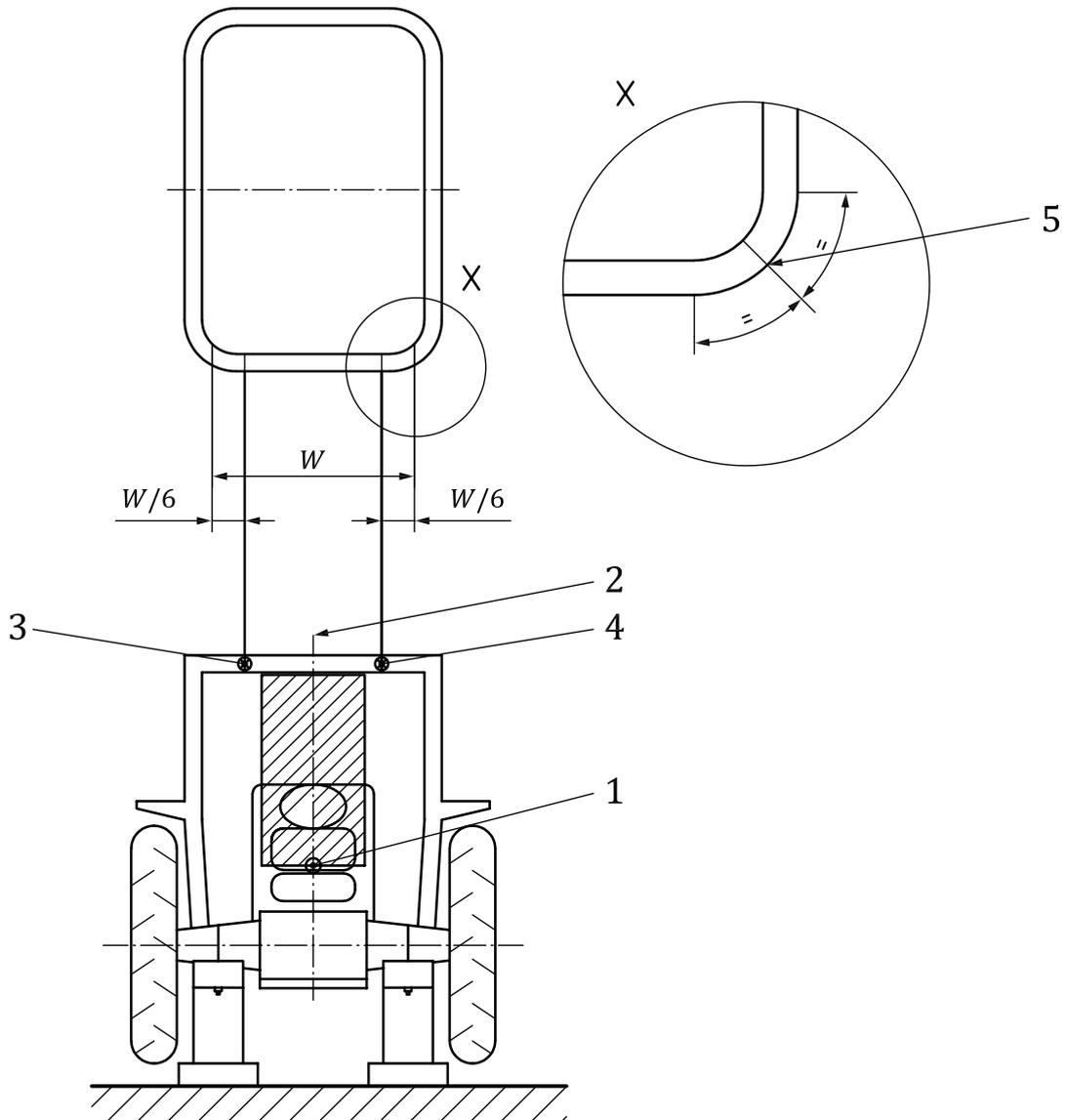

Key

- 1 seat index point (SIP)
- 2 seat reference plane, longitudinal median plane
- 3 point of second longitudinal load application, front or rear
- 4 point of longitudinal load application, rear or front
- 5 end point of W

Figure 7 — Example of ‘ W ’ for ROPS with curved members: 4-post ROPS

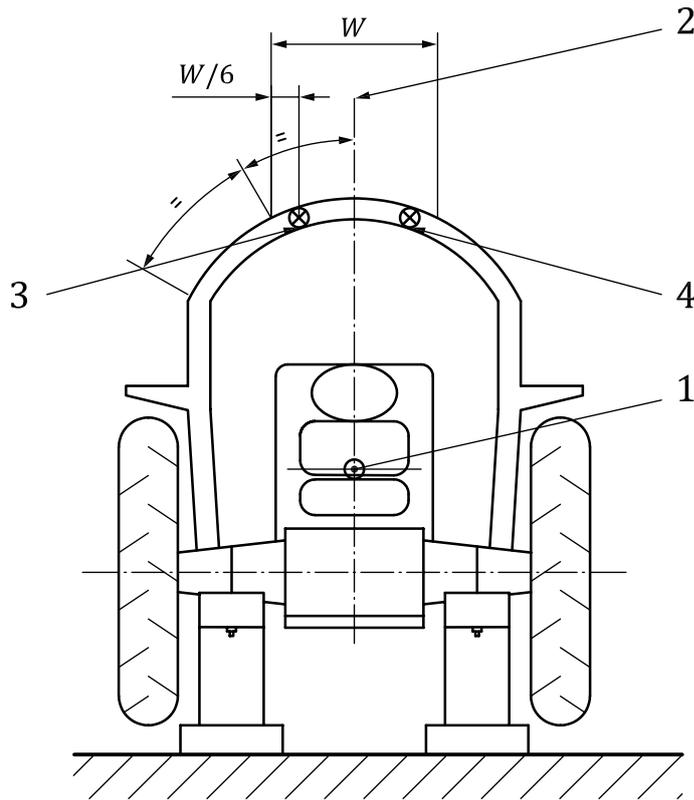

Key

- 1 seat index point (SIP)
- 2 seat reference plane, longitudinal median plane
- 3 point of second longitudinal load application, front or rear
- 4 point of longitudinal load application, rear or front

Figure 8 — Examples of ‘W’ for ROPS with curved members: 2-post ROPS

7.2.2.5 The beam length shall be not less than one-third of the roll-over protective structure’s width (as described above) and not more than 49 mm over this minimum.

7.2.2.6 The test shall be stopped when

- a) the strain energy absorbed by the ROPS is greater than or equal to the required input energy, E_{il1} , in joules, where

$$E_{il1} = 1,4 \cdot m_t$$

or

- b) the ROPS enters the clearance zone (see [Clause 9](#)) or leaves it unprotected.

7.2.3 Loading from side

7.2.3.1 The load shall be applied from the side horizontally normal to the longitudinal median plane. It shall be applied to the roll-over protective structure’s upper extremity at a point $(160 - a_h)$ mm (see [Figures 3](#) and [4](#)) forward of the SIP (see [Figures 3](#) and [4](#), and [Clause 8](#)), or, for a tractor with reversible driver’s position, midway between the SIPs measured in the two driving directions.

7.2.3.2 If it is certain that any particular part of the cab side will touch the ground first when the tractor overturns sideways, the loading shall be applied at that point, provided that this permits uniform load distribution as specified in 7.2.1. In the case of a two-post structure, side loading shall be applied at the structural member uppermost on the side, regardless of the SIP.

7.2.3.3 The beam length shall be as long as practicable, subject to a maximum of 700 mm.

7.2.3.4 The test shall be stopped when

- a) the strain energy absorbed by the ROPS is greater than or equal to the required input energy, E_{is} , in joules, where

$$E_{is} = 1,75 \cdot m_t$$

or

- b) the ROPS enters the clearance zone (see [Clause 9](#)) or leaves it unprotected.

7.3 Crushing tests

7.3.1 Crushing at rear

7.3.1.1 The beam shall be positioned across the rear uppermost structural members ([Figures 9](#) and [10](#)) and the resultant crushing forces shall be located in the vertical reference plane (3.10). The force, F_r , shall be applied, where $F_r = 20m_t$, in newtons. This force shall be maintained for at least 5 s after the cessation of any visually detectable movement of the ROPS.

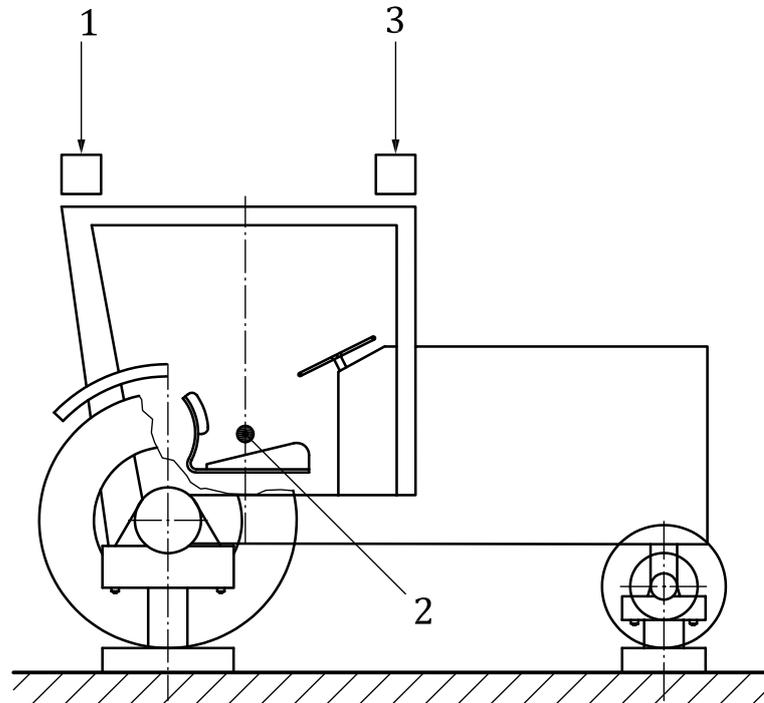

Key

- 1 position of beam for rear crushing test
- 2 seat index point
- 3 position of beam for front crushing test

Figure 9 — Position of beam for front and rear crushing tests on 4-post ROPS

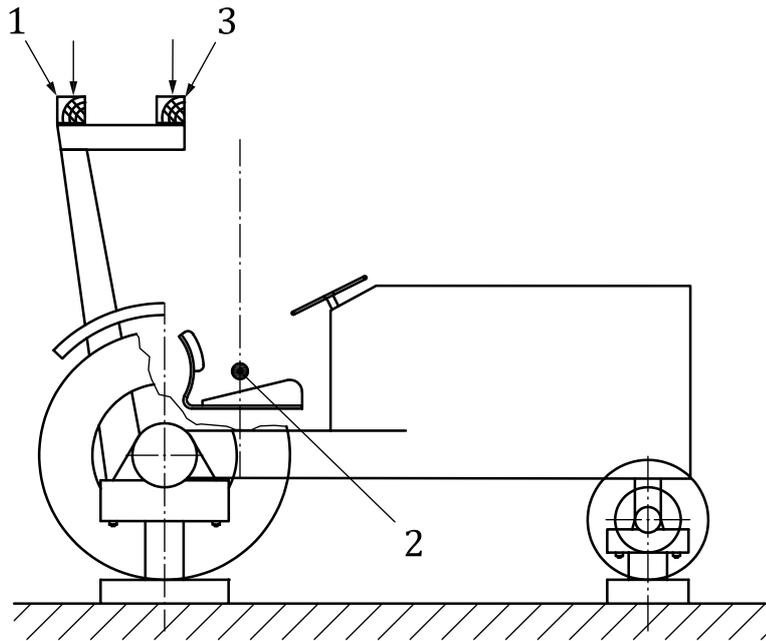

Key

- 1 position of beam for rear crushing test
- 2 seat index point
- 3 position of beam for front crushing test

Figure 10 — Position of beam for front and rear crushing tests on 2-post ROPS

7.3.1.2 Where the rear part of the roll-over protective structure's roof will not sustain the full crushing force, the force shall be applied until the roof is deflected to coincide with the plane joining the upper part of the ROPS to that part of the tractor rear capable of supporting the vehicle mass when overturned. See [Figures 11](#) and [12](#). The force shall then be removed and the tractor or loading force repositioned so that the beam is over that point of the ROPS which would then support the tractor front when completely overturned and the full force applied.

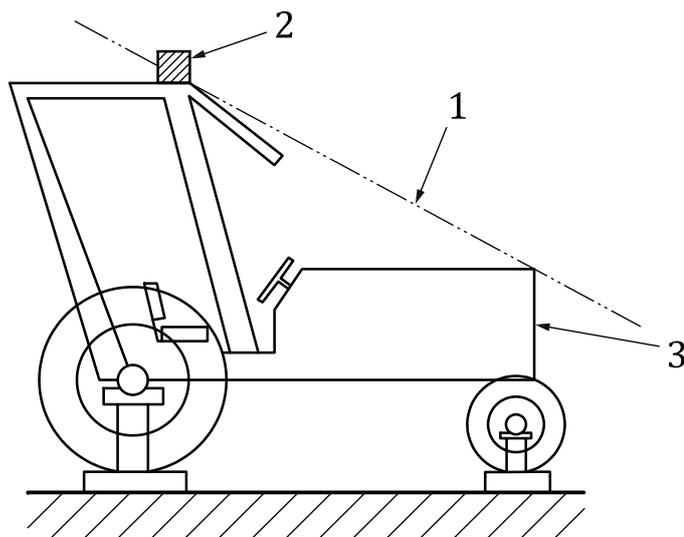

Key

- 1 imaginary ground plane
- 2 second position of the beam for front crushing test where the front part of the roof will not sustain the full crushing force
- 3 part of the tractor capable of supporting the mass of the tractor when overturned

Figure 11 — Application of imaginary ground plane for front and rear crushing tests on 4-post ROPS

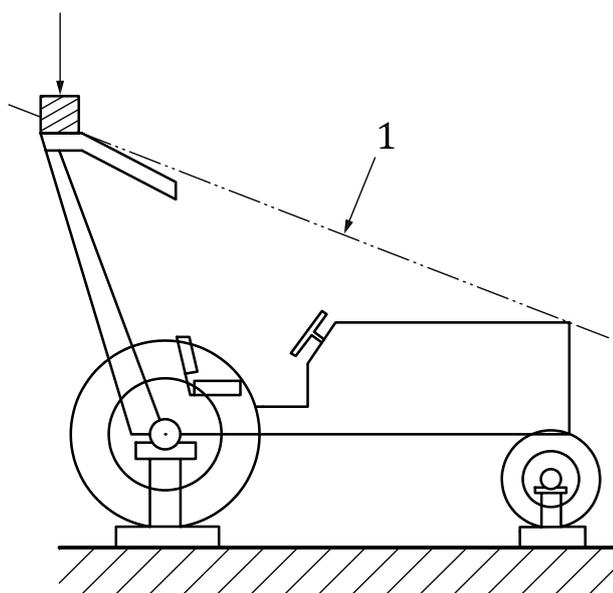

Key

- 1 imaginary ground plane

Figure 12 — Application of imaginary ground plane for front and rear crushing tests on 2-post ROPS

7.3.2 Crushing at front

7.3.2.1 The beam shall be positioned across the front uppermost structural members ([Figures 9 and 10](#)) and the resultant crushing forces shall be located in the vertical reference plane (3.10). The force, F_f , shall be applied, where $F_f = 20 m_t$, in newtons. This force shall be maintained for at least 5 s after the cessation of any visually detectable movement of the ROPS.

7.3.2.2 Where the front part of the roll-over protective structure's roof will not sustain the full crushing force, the force shall be applied until the roof is deflected to coincide with the plane joining the upper part of the ROPS to that part of the tractor front capable of supporting the vehicle mass when overturned. See [Figures 11 and 12](#). The force shall then be removed and the tractor or loading force repositioned so that the beam is over that part of the ROPS which would then support the tractor rear when completely overturned and the full force applied.

7.4 Second longitudinal loading

7.4.1 The second longitudinal loading shall be applied in the opposite direction to, and at the corner furthest from, the longitudinal loading according to [7.2.2](#), but otherwise in accordance with [7.2.1](#).

7.4.2 The test shall be stopped when

- a) the strain energy absorbed by the protective structure is greater than or equal to the required input energy, E_{i12} , in joules, where

$$E_{i12} = 0,35 \cdot m_t$$

or

- b) the ROPS enters the clearance zone (see [Clause 9](#)) or leaves it unprotected.

8 Determination of seat index point (SIP), seat location and adjustment for test

8.1 Seat index point

The seat index point shall be determined in accordance with ISO 5353.

8.2 Seat location and adjustment for test

8.2.1 Where the seat position is adjustable, the seat must be adjusted to its rear uppermost position.

8.2.2 Where the inclination of the backrest is adjustable it must be adjusted to the mid position.

8.2.3 Where the seat is equipped with suspension, the latter must be blocked at mid-travel, unless this is contrary to the instructions clearly laid down by the seat manufacturer.

8.2.4 Where the position of the seat is adjustable only lengthwise and vertically, the longitudinal axis passing through the seat index point shall be parallel with the vertical longitudinal plane of the tractor passing through the centre of the steering wheel and not more than 100 mm from that plane.

8.2.5 For a suspended seat, the manufacturer's directions for setting the suspension shall be followed if provided. Otherwise, the seat suspension shall be set to the suspension mid-travel point. After the installation of the seat on the tractor, SIP becomes a fixed point with respect to the tractor and does not move with the seat through its horizontal and vertical adjustment range.

8.2.6 For extension tests for testing reports that originally used seat reference point (SRP), the required measurements shall be made with reference to SRP instead of SIP and the use of SRP shall be clearly indicated.

9 Clearance zone

9.1 Determination of the clearance zone

The clearance zone is illustrated in [Figures 5](#) and [13](#). The zone is defined in relation to the seat reference plane and the SIP. The seat reference plane is primarily a vertical plane, generally longitudinal to the tractor and passing through the SIP and the centre of the steering wheel. The SIP is determined according to ISO 5353 and is a fixed point with respect to the tractor that does not move as the seat is adjusted away from the mid-position. Normally, the seat reference plane coincides with the longitudinal median plane of the tractor. This seat reference plane shall be assumed to move horizontally with the seat and steering wheel during loading but remain perpendicular to the tractor or the floor of the roll-over protective structure if the latter is resiliently mounted. The clearance zone shall be defined on the basis of [9.2](#) and [9.3](#).

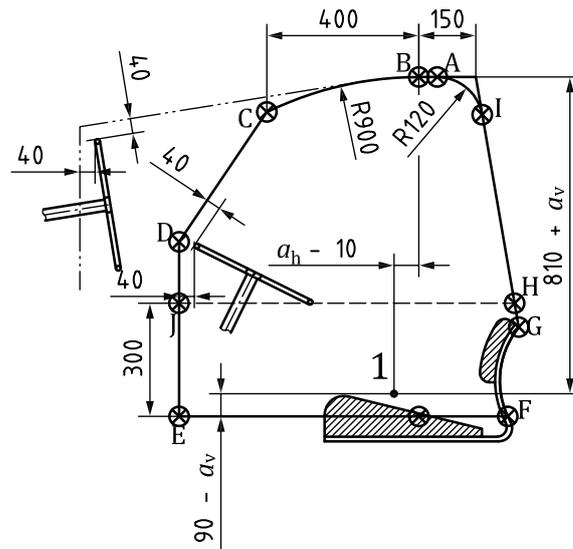

a) Side view

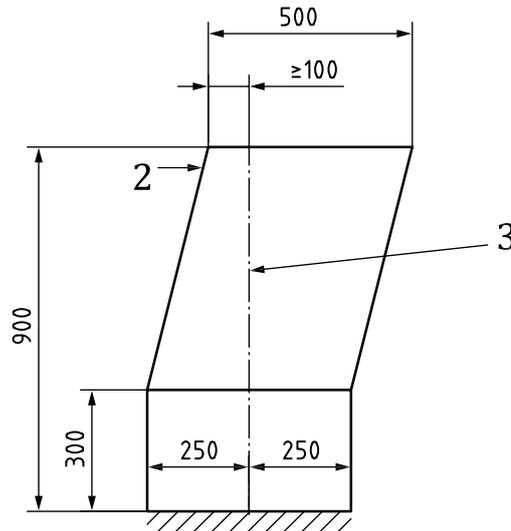

b) Front or rear view

Key

- 1 seat index point
- 2 force
- 3 seat reference plane

Figure 13 — Clearance zone

9.2 Determination of the clearance zone for tractors with a non-reversible seat

The clearance zone for tractors with a non-reversible seat is defined and shall be bounded by the planes listed in 9.2.1 to 9.2.10, the tractor being on a horizontal surface, the seat, where adjustable, adjusted and located as specified in 8.2.1 and 8.2.2, and the steering wheel, where adjustable, adjusted to the mid-position or seated driving.

9.2.1 A horizontal plane, $A_1 B_1 B_2 A_2$, $(810 + a_v)$ mm above the seat index point (SIP) with line $B_1 B_2$ located $(a_h - 10)$ mm behind the SIP.

9.2.2 An inclined plane, $G_1 G_2 I_2 I_1$, perpendicular to the seat reference plane, including both a point 150 mm behind line $B_1 B_2$ and the rearmost point of the seat backrest.

9.2.3 A cylindrical surface, $A_1 A_2 I_2 I_1$, perpendicular to the seat reference plane, having a radius of 120 mm, tangential to the planes defined in [9.2.1](#) and [9.2.2](#).

9.2.4 A cylindrical surface, $B_1 C_1 C_2 B_2$, perpendicular to the seat reference plane, having a radius of 900 mm extending forward for 400 mm and tangential to the plane defined in [9.2.1](#) along line $B_1 B_2$.

9.2.5 An inclined plane, $C_1 D_1 D_2 C_2$, perpendicular to the seat reference plane, joining the surface defined in [9.2.4](#) and passing 40 mm from the forward external edge of the steering wheel, or, in the case of a high steering wheel position, extending forward from line $B_1 B_2$ tangentially to the surface defined in [9.2.4](#).

9.2.6 A vertical plane, $D_1 E_1 E_2 D_2$, perpendicular to the seat reference plane 40 mm forward of the external edge of the steering wheel.

9.2.7 A horizontal plane, $E_1 F_1 F_2 E_2$, passing through a point $(90 - a_v)$ mm below the SIP.

9.2.8 A surface, $G_1 F_1 F_2 G_2$, if necessary curved from the bottom limit of the plane defined in [9.2.2](#) to the horizontal plane defined in [9.2.7](#), perpendicular to the seat reference plane, and in contact with the seat backrest throughout its length.

9.2.9 Vertical planes, $J_1 E_1 F_1 G_1 H_1$ and $J_2 E_2 F_2 G_2 H_2$, which extend upwards from plane $E_1 F_1 F_2 E_2$ for 300 mm, and where the distances $E_1 E_0$ and $E_2 E_0$ are 250 mm.

9.2.10 Parallel planes, $A_1 B_1 C_1 D_1 J_1 H_1 I_1$ and $A_2 B_2 C_2 D_2 J_2 H_2 I_2$, inclined so that the plane upper edge of the plane on the side on which the force is applied is at least 100 mm from the seat reference plane.

9.3 Determination of the clearance zone for tractors with a reversible driver's position

For tractors with a reversible driver's position (reversible seat and steering wheel), the zone of clearance is the envelope of the two clearance zones defined by the two different positions of the steering wheel and the seat. See [Figures 14 a\)](#) and [14 b\)](#).

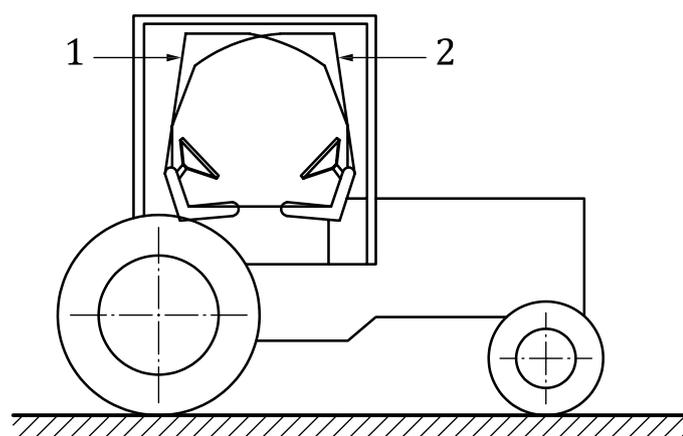

a) Protective cab

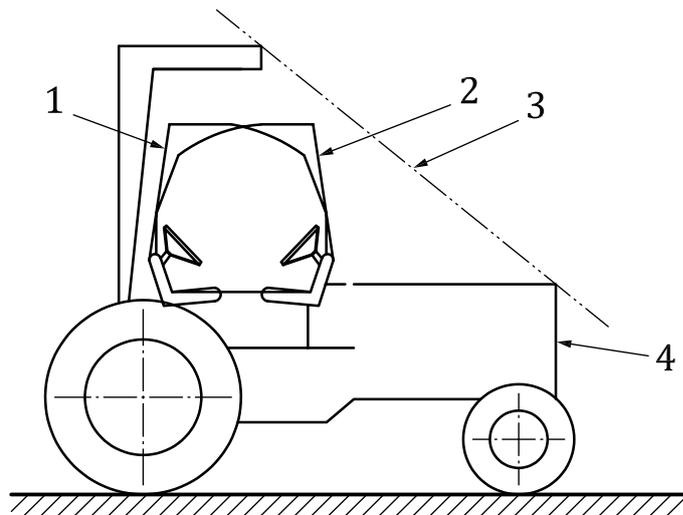

b) Rear roll bar frame

Key

- 1 clearance zone for the forward facing seat position
- 2 clearance zone for the rearward facing seat position
- 3 imaginary ground plane
- 4 part of the tractor capable of supporting the mass of the tractor when overturned

Figure 14 — Clearance zone for tractor with reversible seat and steering wheel

9.4 Optional seats

9.4.1 In the case of tractors that can be fitted with optional seats, the envelope comprising the SIPs of all options offered shall be used during the tests. The protective structure shall not enter the larger clearance zone which takes account of these different seat index points.

9.4.2 In the case where a new seat option is offered after the test has been performed, it shall be determined whether the clearance zone around the new SIP falls within the envelope previously established. If not, a new test shall be performed.

10 Tolerances

Measurements during the tests shall be made to the following tolerances:

- a) time $\pm 0,2$ s;
- b) distance $\pm 0,5$ %;
- c) force $\pm 1,0$ %;
- d) mass $\pm 0,5$ %.

11 Acceptance conditions

11.1 General

For the ROPS to be accepted, it shall fulfill the conditions in [11.2](#) to [11.7](#) during and after the tests. On articulated tractors, the clearance zone shall remain protected at any angle of articulation of the tractor when overturned.

11.2 Clearance zone

No part shall enter the clearance zone as defined in [Clause 9](#). No part shall strike the seat during the tests. Furthermore, the clearance zone shall not be outside the protection given by the ROPS (see the Note to 3.1). For this purpose, it shall be considered to be outside if any part of it would have come into contact with flat ground if the tractor had overturned in the direction from which the blow was struck. To estimate this, the tyres or tracks and track width setting shall be the smallest standard fitting specified by the manufacturer.

NOTE It is the responsibility of the tractor manufacturer to ensure that other components not present during the ROPS test do not present a hazard to the operator in the event of an overturn by entering into the clearance zone.

11.3 Recording permanent deflection

After the final crushing test, the permanent deflection of the protective structure shall be recorded. For this purpose, before the start of the test, the position of the main protective structure members in relation to the SIP shall be recorded. Any displacement of the members resulting from the loading tests and any change of the height of the front and back members of the roof of the protective structure shall be recorded.

11.4 Required force

At the point where the required energy is met in each of the specified horizontal loading tests, the force shall exceed $0,8F_{\max}$.

11.5 Overload test

11.5.1 An overload test shall be required if the force drops by more than 3 % over the last 5 % of the deflection attained while absorbing the required energy (see [Figures 15](#) and [16](#)).

11.5.2 The overload test shall consist of a continuation of the horizontal loading in increments of 5 % of the original required energy up to a total of 20 % additional energy (see [Figure 17](#)).

11.5.2.1 The overload test shall be successfully completed if,

- after the absorption of 5 %, 10 % or 15 % additional energy, the force drops by less than 3 % for each 5 % increment and is greater than $0,8F_{\max}$, and
- after the absorption of 20 % additional energy, the force is greater than $0,8F_{\max}$.

11.5.2.2 Additional cracks or tears, entry into the clearance zone, or lack of protection of the clearance zone is permitted during this overload test. After removing the load, the structure shall not be in the clearance zone and shall protect the clearance zone.

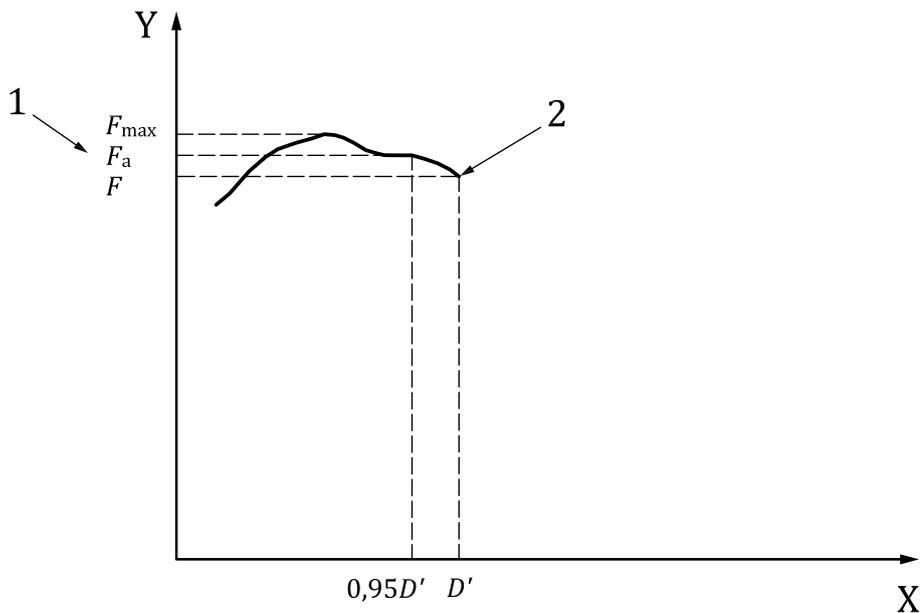

Key

- 1 Locate F_a in relation to $0,95D'$
- 2 Overload test not necessary as $F_a \leq 1,03 F$

Figure 15 — Static load force load relative to deflection: Overload test not necessary

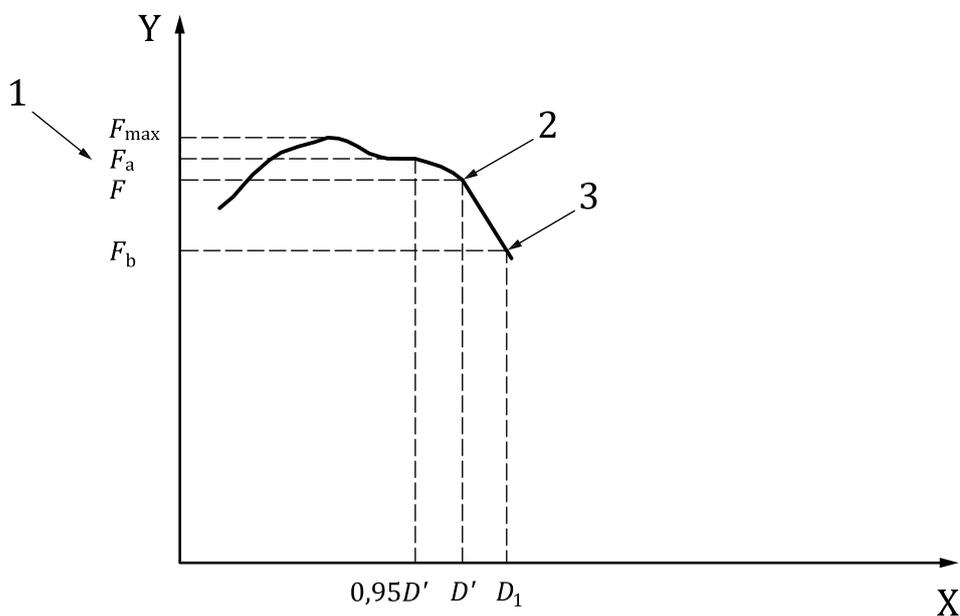

Key

- 1 Locate F_a in relation to $0,95D'$
- 2 Overload test necessary as $F_a > 1,03 F$
- 3 Overload test performance satisfactory as $F_b > 0,97F$ and $F_b > 0,8F_{max}$

Figure 16 — Static load force load relative to deflection: Overload test necessary

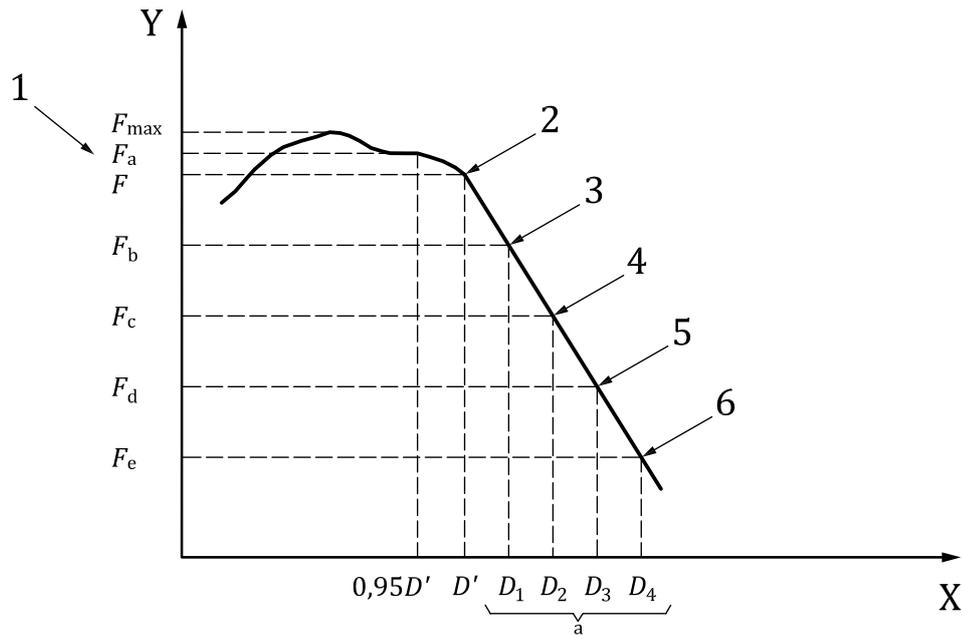
**Key**

- 1 Locate F_a in relation to $0,95D'$
- 2 Overload test necessary as $F_a > 1,03 F$
- 2 $F_b < 0,97 F$ therefore further overload necessary
- 3 $F_c < 0,97 F_b$ therefore further overload necessary
- 4 $F_d < 0,97 F_c$ therefore further overload necessary
- 5 Overload test performance satisfactory, if $F_e > 0,8 F_{max}$
- 6 Failure at any stage when load drops below $0,8 F_{max}$
- 7 Locate F_a in relation to $0,95D'$

Figure 17 — Static load force load relative to deflection: Continuing overload test

11.6 Additional conditions

11.6.1 The required force shall be sustained in both crushing tests.

11.6.2 There shall be no protruding member or component which would be likely to cause serious injury during an overturning accident or which, through the deformation occurring, might trap the operator, for example by the leg or foot.

11.6.3 There shall be no other components presenting a serious hazard to the operator.

11.7 Cold weather embrittlement

11.7.1 When applicable, cold weather embrittlement properties shall be verified either by performing the tests given in [Clause 7](#) at -18°C or colder, or in accordance with [Annex A](#).

11.7.2 If any ROPS structural members or mounts are fabricated from material not specified in [Annex A](#), the dynamic ROPS test, based on ISO 3463[4] or OECD Code 3,[8] shall be conducted with the structural members material and mounts temperature at -18°C or colder.

NOTE In some countries, ROPS are required to meet the cold weather embrittlement requirements of [Annex A](#), where partial list of those countries is given.

12 Seatbelt anchorage performance

12.1 Optional seatbelt anchorage performance tests, if conducted, shall be in accordance with ISO 3776-2[5].

NOTE In some countries, seat belts are required with the ROPS protective structure providing a safety system to the operator from accidental overturning during normal operation.

13 Labelling

13.1 If a label is required, it shall be durable and permanently attached to the main structure such that it can be easily read. It shall be protected from damage and shall contain at least the following information:

- a) name and address of the manufacturer or constructor of the ROPS;
- b) ROPS identification number (design or serial number);
- c) tractor make, model(s) or series number(s) the ROPS is designed to fit;
- d) reference to this International Standard.

14 Extension to other tractor models

14.1 Administrative extension

If there are changes in the make, denomination or marketing features of the tractor or protective structure tested or listed in the original test report, the testing station that has carried out the original test may issue an “administrative extension report”. This extension report shall contain a reference to the original test report.

14.2 Technical extension

When technical modifications occur on the tractor or the protective structure, or in the means of attaching the protective structure to the tractor, the testing station that has carried out the original test may issue a “technical extension report” as follows.

14.2.1 Extension of the structural test results to other models of tractors

The loading and crushing tests need not be carried out on each model of tractor, provided that the protective structure and tractor comply with the conditions listed in [14.2.1.1](#) to [14.2.1.5](#).

14.2.1.1 The structure shall be identical to the one tested.

14.2.1.2 The required energy shall not exceed the energy calculated for the original test by more than 5 %. This 5 % limit shall also apply to extensions in the case of substituting tracks for wheels on the same tractor.

14.2.1.3 The means of attachment and the tractor components to which the attachment is made shall be identical.

14.2.1.4 Any components such as mudguards and bonnet that may provide support for the protective structure shall be identical.

14.2.1.5 The position and critical dimensions of the seat in the protective structure and the relative position of the protective structure on the tractor shall be such that the clearance zone will have remained within the protection of the deflected structure throughout all tests. [This shall be checked by using the

same reference of clearance zone as in the original test report, respectively Seat Reference Point (SRP) or Seat Index Point (SIP).]

14.2.2 Extension of the structural test results to modified models of the protective structure

This applies when the provisions of [14.2.1](#) are not fulfilled, but shall not be used when the means of attaching the protective structure to the tractor do not follow the same principle (e.g. rubber supports replaced by a suspension device):

14.2.2.1 Modifications having no loading on the results of the initial test (e.g. weld attachment of the mounting plate of an accessory in a non-critical location on the structure), addition of seats with different SIP location in the protective structure [subject to checking that the new clearance zone(s) remain(s) within the protection of the deflected structure throughout all tests].

14.2.2.2 Modifications having a possible loading on the results of the original test without calling into question the acceptability of the protective structure (e.g. modification of a structural component, modification of the method of attachment of the protective structure to the tractor), in which case a validation test may be carried out and the test results drafted in the extension report.

14.2.3 Type extension limits

14.2.3.1 Limits for this type extension are fixed and are listed in [14.2.3.1.1](#) to [14.2.3.1.3](#).

14.2.3.1.1 No more than five extensions may be accepted without a validation test.

14.2.3.1.2 The results of the validation test will be accepted for extension if all the acceptance conditions of the Code are fulfilled and if the force measured when the required energy level has been reached in the various horizontal load tests does not deviate from the force measured when the required energy has been reached in the original test by more than $\pm 7\%$ and the deflection measured when the required energy level has been reached in the various horizontal load tests does not deviate from the deflection measured when the required energy has been reached in the original test report by more than $\pm 7\%$;

14.2.3.1.3 More than one protective structure modification may be included in a single extension report if they represent different options of the same protective structure, but only one validation test shall be accepted in a single extension report and the options not tested shall be described in a specific section of the extension report.

14.2.4 Increase of the declared reference mass

An increase of the reference mass may be declared by the manufacturer for a protective structure that has already been tested. If the manufacturer wishes to keep the same approval number, it is possible to issue an extension report after having carried out a validation test (the limits of $\pm 7\%$ specified in [14.2.3.1.2](#) are not then applicable).

15 Test report

15.1 The test report shall contain at least the information according to [Annex B](#).

If the ROPS is claimed to have properties resistant to cold weather embrittlement, the manufacturer shall give details which shall be included in the test report (see [Annex B](#)).

Annex A (normative)

Optional requirements for providing resistance to brittle fracture of roll-over protective structure at reduced operating temperature

The following requirements and procedure are intended to provide strength and resistance to brittle fracture at reduced temperature. The following minimum material requirements shall be met in judging the roll-over protective structure's suitability at a reduced operating temperature in regions where this additional operating protection is required.

In certain countries, testing for cold weather embrittlement according to this annex is mandatory. See [Table A.1](#).

Table A.1 — Some countries where cold weather embrittlement testing according to this annex is mandatory

| Country | Country code |
|---------------|--------------|
| Canada | CA |
| United States | US |

NOTE The requirements and procedure specified in A.3 and A.4 are provided until suitable International Standards can be developed.

A.1 Bolts and nuts used to attach the ROPS to the machine frame and to connect structural parts of the ROPS shall be property class 8.8, 9.8 or 10.9 in accordance with ISO 898-1^[2] for bolts and property class 8, 9 or 10 in accordance with ISO 898-2^[3] for nuts.

A.2 All welding electrodes used in the fabrication of structural members and mounts shall be compatible with the ROPS material specified in A.3.

A.3 Steel materials for the tractor structural members that are expected to absorb energy during ROPS testing shall be of controlled toughness material exhibiting minimum Charpy V-notch impact energy requirements according to [Table A.2](#).

NOTE Steel with an as-rolled thickness less than 2,5 mm and with a carbon content less than 0,2 % is considered to meet this requirement.

Structural members of the roll-over protective structure made from materials other than steel shall have equivalent low temperature impact resistance. Specimens shall be "longitudinal" and taken from flat stock, tubular or structural sections before forming or welding for use in the roll-over protective structure. Specimens from tubular or structural sections shall be taken from the middle of the biggest side and shall not include welds.

A.4 The Charpy V-notch tests shall be made in accordance with the procedure given in ASTM A370¹⁾, except that specimen sizes shall be in accordance with the dimensions given in [Table A.2](#).

A.5 An alternative to this procedure is to use killed or semi-killed steel, for which a specification shall be provided.

1) Reference to ASTM A370 is to be replaced as soon as a corresponding International Standard becomes available.

Table A.2 — Minimum Charpy V-notch energy requirements for ROPS material at specimen temperatures of -20°C and -30°C

| Specimen size mm | Absorbed energy | |
|-----------------------|-----------------|--------------------------|
| | -30 °C J | -20 °C J ^b |
| 10 x 10 ^a | 11 | 27,5 |
| 10 x 9 | 10 | 25 |
| 10 x 8 | 9,5 | 24 |
| 10 x 7,5 ^a | 9,5 | 24 |
| 10 x 7 | 9 | 22,5 |
| 10 x 6,7 | 8,5 | 21 |
| 10 x 6 | 8 | 20 |
| 10 x 5 ^a | 7,5 | 19 |
| 10 x 4 | 7 | 17,5 |
| 10 x 3,3 | 6 | 15 |
| 10 x 3 | 6 | 15 |
| 10 x 2,5 ^a | 5,5 | 14 |

^a Indicates preferred size. Specimen size shall be no less than largest preferred size that the material permits.

^b The energy requirement at -20 °C is 2,5 times the value specified for -30 °C. Other factors affect impact energy strength, i.e. direction of rolling, yield strength, grain orientation and welding. These factors shall be considered when selecting and using steel.

Annex B (normative)

Test report for roll-over protective structure

B.1 General

Use SI units in the test report, followed by other units (e.g. Imperial and U.S. customary), if necessary.

- Protective structure manufacturer's name and address:
- Submitted for test by:
- Make of protective structure:
- Model of the protective structure:
- Type of protective structure: cab, frame, rear roll bar, cab with integrated frame, etc.
- Date and location of test:

B.2 Specification of test tractor

B.2.1 Identification of tractor to which protective structure is fitted for the test

B.2.1.1 General

- Make of tractor:²⁾
- Model (trade name):
- Type: 2WD or 4WD; rubber or steel tracks (if applicable); articulated 4 WD or articulated 4 WD with twin (dual) wheels (if applicable):
- 1st Serial No. or prototype No.:
- Serial No.:

B.2.2 Tractor mass

| | |
|---|-------|
| Front | kg |
| Rear | kg |
| Total | kg |
| — Maximum permissible mass of tractor: | kg |
| — Reference mass used for calculating loading energies and crushing forces: | kg |
| — Mass ratio value - (Maximum Permissible Mass / Reference Mass): | |

2) Possibly different from tractor manufacturer's name.

B.2.3 Minimum track and tyre sizes

| | Minimum track | Tyre sizes |
|-------|---------------|------------|
| Front | mm | |
| Rear | mm | |

B.2.4 Tractor seat

- Tractor with a reversible driver's position (reversible seat and steering wheel): Yes / No
- Make/ type/ model of seat:
- Make/ type/ model of optional seat(s) and position(s) of the seat index point (SIP):
 - (description of seat 1 and SIP position)
 - (description of seat 2 and SIP position)
 - (description of seat _ and SIP position)

B.3 Specification of protective structure**B.3.1** Photographs from side and rear showing mounting details including mudguards

B.3.2 General arrangement drawing of the side and the rear of the structure including position of the seat index points (SIP), details of mountings and position of the front part of the tractor capable of supporting the tractor when overturned (if necessary). The main dimensions must figure on the drawings, including external dimensions of tractor with protective structure fitted and main interior dimensions.

B.3.3 Brief description of the protective structure comprising:

- type of construction;
- details of mountings;
- details of the front part of the tractor capable of supporting the tractor when overturned (if necessary)
- means of access and escape;
- additional frame: Yes/No

B.3.4 Tiltable or not tiltable/ folding or not folding structure

- Tiltable / not tiltable³⁾

If it is necessary to tilt with any tools, this should be stated as follows:

- Tiltable with tools/ tiltable without tools³⁾
- Folding/ not folding³⁾

If it is necessary to fold with any tools, this should be stated as follows:

- Folding with tools/ folding without tools³⁾

3) Delete as appropriate.

B.3.5 Dimensions

Dimensions shall be measured with the seat loaded as required by ISO 5353 to determine the seat index point and then located as required by [Clause 9](#) for determination of the clearance zone.

When the tractor is fitted with different optional seats or has a reversible driver's position (reversible seat and steering wheel), the dimensions in relation to the seat index points shall be measured in each case (SIP 1, SIP 2, etc.).

- Height of roof members above the seat index point: mm
- Height of roof members above the tractor footplate: mm
- Interior width of the protective structure (810 +av) mm above the seat index point: mm
- Interior width of the protective structure vertically above the seat index point at the level of centre of the steering wheel: mm
- Distance from the centre of the steering wheel to the right-hand side of the protective structure: mm
- Distance from the centre of the steering wheel to the left-hand side of the protective structure: mm
- Minimum distance from the steering wheel rim to the protective structure: mm
- Horizontal distance from the seat index point to the rear of the protective structure at a height of (810 + av) mm above the seat index point: mm
- Position (with reference to the rear axle) of the front part of the tractor capable of supporting the tractor when overturned (if necessary):
 - Horizontal distance mm
 - Vertical distance mm

B.3.6 Details of materials used in the construction of the protective structure and specifications of steels used

Steel specifications shall be in conformity with ISO 630-1:2011.

- Main frame: (parts – materials –sizes)
 - Steel standard and reference:
- Mountings: (parts – materials –sizes)
 - Steel standard and reference:
- Assembly and mounting bolts: (parts – sizes)
- Roof (if equipped): (parts – materials –sizes)
- Cladding (if equipped): (parts – materials –sizes)
- Glass (if equipped): (type – grade – sizes)
- Front part of the tractor capable of supporting the tractor when overturned (if necessary) (parts – materials –sizes)

B.3.7 Details of tractor manufacturer's reinforcements on original parts

B.4 Test results

B.4.1 Static loading and crushing tests

B.4.1.1 Condition of tests

- Loading was applied:
 - to the rear left/right
 - to the front right/left
 - to the side right/left
- Mass used for calculating loading energies and crushing forces: kg
- Energies and forces applied:
 - rear: kJ
 - front: kJ
 - side: kJ
 - crushing force: kN

B.4.1.2 Permanent deflections measured after the tests

Permanent deflections of the extremities of the protective structure measured after the series of tests:

- Back (forwards / backwards):
 - left-hand: mm
 - right-hand: mm
- Front (forwards / backwards):
 - left-hand: mm
 - right-hand: mm
- Sideways (to the left / to the right):
 - front: mm
 - rear: mm
- Top (downwards / upwards):
 - rear:
 - left-hand: mm
 - right-hand: mm
 - front:
 - left-hand: mm
 - right-hand: mm

Difference between total instantaneous deflection and residual deflection during side loading test (elastic deflection): mm

Statement:

The acceptance conditions of these tests relative to the protection of the zone of clearance are fulfilled. The structure is a roll-over protective structure in accordance with this International Standard.

B.4.1.3 Curves

A copy of the force/deflection curves derived during the tests shall be included.

If a horizontal overload test was required, the reason for the overload shall be described and the copy of additional force/deflection curves obtained during overload shall be included.

B.4.2 Cold weather performance (resistance to brittle fracture)

Method used to identify resistance to brittle fracture at reduced temperature:

Steel specifications shall be in conformity with ISO 630-1:2011.

Steel specification: (reference and relevant standard).

B.4.3 Tractor(s) to which the protective structure is fitted

See [Table B.1](#).

Table B.1 — Tractors to which the protective structure is fitted

| Test reference number: | | | | | | | | | | |
|------------------------|-------|-----------------------|----------------------|-------|------|-------|----------|------------|---------------|------|
| Make | Model | Type | Other specifications | Mass | | | Tiltable | Wheel-base | Minimum track | |
| | | 2/4 Wheel Drive, etc. | where applicable | Front | Rear | Total | | | Front | Rear |
| | | | | kg | kg | kg | Yes/No | mm | mm | |
| | | | | | | | | | | |
| | | | | | | | | | | |

B.5 Minor modification certificate

- Test reference number according to ISO 5700:
- Copy of the referenced original test report:
- Date and location of test:
- Date of approval:
- Modification reference number: MOD

Previous modification certificate (MOD.....) remains/does not remain valid.

B.5.1 Specification of protective structure

- Frame or cab:
- Manufacturer:
- Submitted for test by:
- Make:
- Model:
- Type:
- Serial number from which modification applies:

B.5.2 Denomination of tractors to which protective structure is fitted

| Make and model | Number of driving wheels | Reference number |
|----------------|--------------------------|------------------|
| | | |
| | | |
| | | |
| | | |

B.5.3 Details of modifications

Since the original test report the following modifications have been made:

.....

B.5.4 Statement

The effect of these modifications on the strength of the protective structure has been examined.

The modifications are considered not to affect the results of the original test.

The original test report therefore applies to the protective structure of the modified tractor.

Drafted on the responsibility of _____, which carried out the original test, this certificate is circulated as an annex to the original test report and subject to the same circulation.

Signature:

Date:

Location:

Annex C **(informative)**

Designation of Maintenance Agency

A Maintenance Agency has been established by the ISO Technical Management Board (TMB) to ensure that technical harmonization can be maintained between ISO/TC 23/SC 2 Standards and OECD Tractor Test Codes. It operates through guidelines approved by the TMB, accessible at <http://standards.iso.org/iso/5700>, that entrust it to the following functions:

- a) to receive the requests for changes from recognized ISO/TC23/SC 2 P-members;
- b) to evaluate and resolve the requests for changes;
- c) to publish the approved changes.

Changes to this International Standard will be announced by the MA Secretariat to ISO/TC 23/SC 2 and will be made publicly available at <http://standards.iso.org/iso/5700>. They constitute authoritative amendments to [Clauses 1](#) to [15](#) and to the annexes of this International Standard.

Bibliography

- [1] ISO 612:1978, *Road vehicles — Dimensions of motor vehicles and towed vehicles — Terms and definitions*
- [2] ISO 898-1, *Mechanical properties of fasteners made of carbon steel and alloy steel — Part 1: Bolts, screws and studs with specified property classes — Coarse thread and fine pitch thread*
- [3] ISO 898-2, *Mechanical properties of fasteners made of carbon steel and alloy steel — Part 2: Nuts with specified property classes — Coarse thread and fine pitch thread*
- [4] ISO 3463, *Tractors for agriculture and forestry — Roll-over protective structures (ROPS) — Dynamic test method and acceptance conditions*
- [5] ISO 3776-2, *Tractors and machinery for agriculture — Seat belts — Part 2: Anchorage strength requirements*
- [6] ISO 12003-1, *Agricultural and forestry tractors — Roll-over protective structures on narrow-track wheeled tractors — Part 1: Front-mounted ROPS*
- [7] ISO 12003-2, *Agricultural and forestry tractors — Roll-over protective structures on narrow-track wheeled tractors — Part 2: Rear-mounted ROPS*
- [8] OECD Test Code 3: July 2012, *OECD standard code for the official testing of protective structures on agricultural and forestry tractors (Dynamic test)*
- [9] OECD Test Code 4: July 2012, *OECD standard code for the official testing of protective structures on agricultural and forestry tractors (Static test)*

