**Agricultural tractors and machinery —
Power take-off drive shafts and power-
input connection —**

Part 1:
**General manufacturing and safety
requirements**

*Tracteurs et matériels agricoles — Arbres de transmission à cardans de
prise de force et arbre récepteur de la machine —*

Partie 1: Exigences générales de fabrication et de sécurité



PDF disclaimer

This PDF file may contain embedded typefaces. In accordance with Adobe's licensing policy, this file may be printed or viewed but shall not be edited unless the typefaces which are embedded are licensed to and installed on the computer performing the editing. In downloading this file, parties accept therein the responsibility of not infringing Adobe's licensing policy. The ISO Central Secretariat accepts no liability in this area.

Adobe is a trademark of Adobe Systems Incorporated.

Details of the software products used to create this PDF file can be found in the General Info relative to the file; the PDF-creation parameters were optimized for printing. Every care has been taken to ensure that the file is suitable for use by ISO member bodies. In the unlikely event that a problem relating to it is found, please inform the Central Secretariat at the address given below.

© ISO 2005

All rights reserved. Unless otherwise specified, no part of this publication may be reproduced or utilized in any form or by any means, electronic or mechanical, including photocopying and microfilm, without permission in writing from either ISO at the address below or ISO's member body in the country of the requester.

ISO copyright office
Case postale 56 • CH-1211 Geneva 20
Tel. + 41 22 749 01 11
Fax + 41 22 749 09 47
E-mail copyright@iso.org
Web www.iso.org

Published in Switzerland

Contents

Page

Foreword.....	iv
1 Scope	1
2 Normative references	1
3 Terms and definitions	1
4 Manufacturing requirements	7
5 Safety requirements	9
6 Information for use	16
Bibliography	19

Foreword

ISO (the International Organization for Standardization) is a worldwide federation of national standards bodies (ISO member bodies). The work of preparing International Standards is normally carried out through ISO technical committees. Each member body interested in a subject for which a technical committee has been established has the right to be represented on that committee. International organizations, governmental and non-governmental, in liaison with ISO, also take part in the work. ISO collaborates closely with the International Electrotechnical Commission (IEC) on all matters of electrotechnical standardization.

International Standards are drafted in accordance with the rules given in the ISO/IEC Directives, Part 2.

The main task of technical committees is to prepare International Standards. Draft International Standards adopted by the technical committees are circulated to the member bodies for voting. Publication as an International Standard requires approval by at least 75 % of the member bodies casting a vote.

Attention is drawn to the possibility that some of the elements of this document may be the subject of patent rights. ISO shall not be held responsible for identifying any or all such patent rights.

ISO 5673-1 was prepared by Technical Committee ISO/TC 23, *Tractors and machinery for agriculture and forestry*, Subcommittee SC 4, *Tractors*.

This first edition of ISO 5673-1, together with ISO 5673-2, cancels and replaces ISO 5673:1993, of which it constitutes a technical revision.

ISO 5673 consists of the following parts, under the general title *Agricultural tractors and machinery — Power take-off drive shafts and power-input connection*:

- *Part 1: General manufacturing and safety requirements*
- *Part 2: Specification for use of PTO drive shafts, and position and clearance of PTO drive line and PIC for various attachments*

Agricultural tractors and machinery — Power take-off drive shafts and power-input connection —

Part 1: General manufacturing and safety requirements

1 Scope

This part of ISO 5673 specifies the power take-off (PTO) drive shafts of a tractor or self-propelled machine used in agriculture and the power-input connection (PIC) of its implement, establishing a method for determining PTO static and dynamic torsional strength while giving manufacturing and safety requirements. It is applicable only to those PTO drive shafts and guards mechanically linked to the shaft by at least two bearings. It is not applicable to PTO drive shafts guarded by location or to the mechanical characteristics of overrun devices and torque limiters, nor are environmental aspects considered; neither is it applicable to PTO drive shafts and their guards manufactured before the date of its publication.

2 Normative references

The following referenced documents are indispensable for the application of this document. For dated references, only the edition cited applies. For undated references, the latest edition of the referenced document (including any amendments) applies.

ISO 500-3:2004, *Agricultural tractors — Rear mounted power take-off types 1, 2 and 3 — Part 3: Main PTO dimensions and spline dimensions, location of PTO*

ISO 4254-1, *Agricultural machinery — Safety — Part 1: General requirements*¹⁾

ISO 5674:2004, *Tractors and machinery for agriculture and forestry — Guards for power take-off (PTO) drive-shafts — Strength and wear tests and acceptance criteria*

ISO 11684:1995, *Tractors, machinery for agriculture and forestry, powered lawn and garden equipment — Safety signs and hazard pictorials — General principles*

3 Terms and definitions

For the purposes of this document, the following terms and definitions apply.

3.1

power take-off (PTO) drive shaft

assembly consisting of two joints, telescopic members and a guard which is mechanically linked to the shaft by at least two bearings used to transmit rotational power from the PTO of a tractor or self-propelled machine to an implement and/or between parts of the implement

1) To be published. (Revision of ISO 4254-1:1989)

**3.1.1
primary PTO drive shaft**

detachable PTO drive shaft linking the PTO of the tractor or self-propelled machine to the PIC of an implement

See Figure 1.

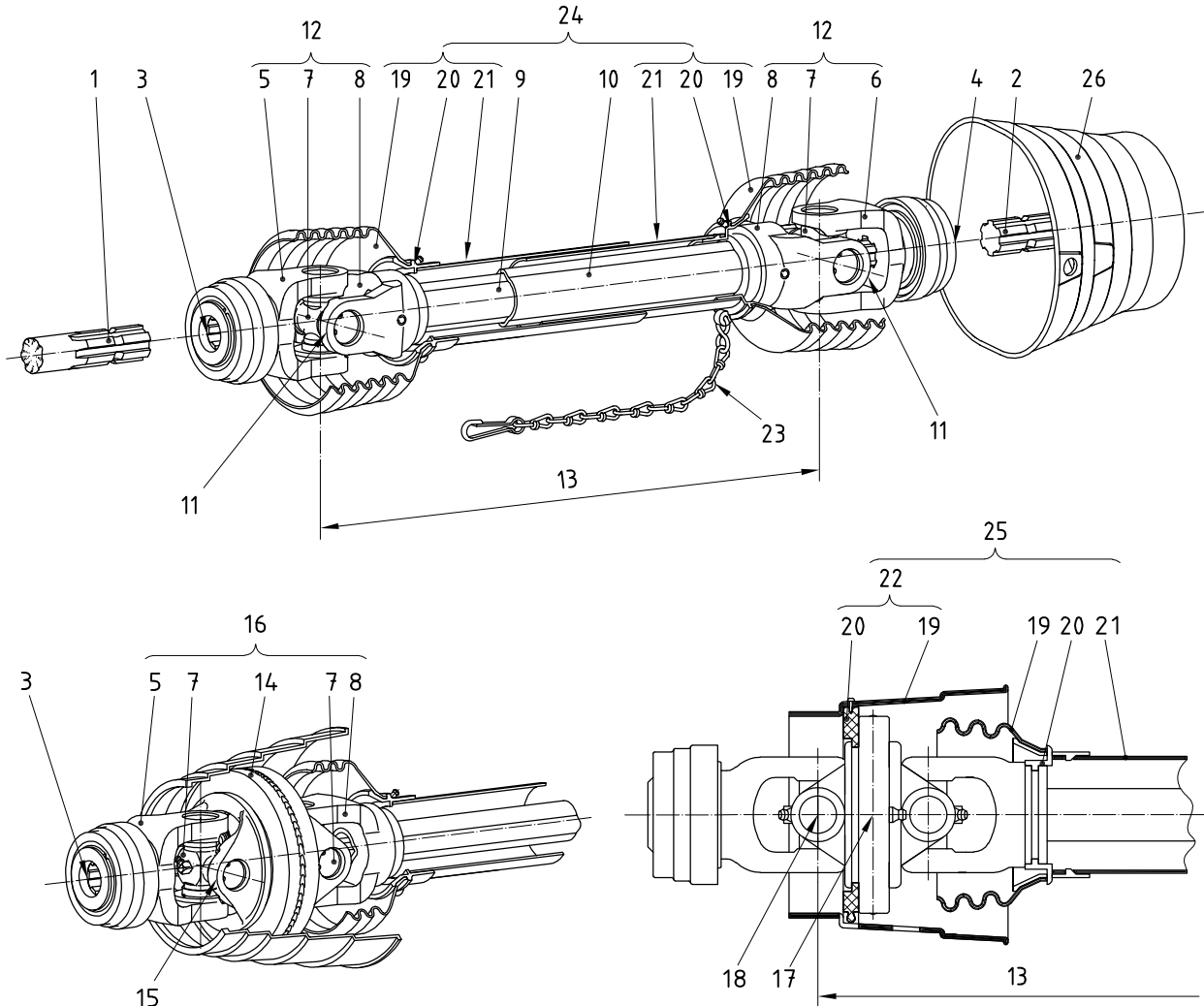

Key

- | | |
|--|---|
| 1 power take off shaft (PTO) | 14 double yoke |
| 2 power-input connection (PIC) | 15 end of double yoke of outer joint |
| 3 PTO yoke bore | 16 wide-angle universal joint |
| 4 PIC yoke bore | 17 centre of articulation of wide-angle universal joint |
| 5 PTO yoke | 18 centre of outer joint |
| 6 PIC yoke | 19 guard cone |
| 7 journal cross-assembly | 20 guard bearing |
| 8 inner yoke | 21 guard tube |
| 9 inner telescopic member | 22 separate guard of wide angle universal joint |
| 10 outer telescopic member | 23 restraining member (as an example) |
| 11 end of inner yoke of universal joint | 24 PTO drive shaft guard |
| 12 universal joint | 25 PTO wide-angle drive shaft guard |
| 13 PTO drive shaft, closed and extended length | 26 PIC guard |

Figure 1 — Primary PTO drive shaft, power-input connection and associated components

3.1.2**secondary PTO drive shaft**

PTO drive shaft, detachable or otherwise, following the PIC of an implement and having the same basic design as a primary PTO drive shaft

See Figure 2.

3.2**PTO drive shaft attachment**

shaft to which a PTO drive shaft is connected

3.2.1**power take-off shaft****PTO**

external shaft on the rear of the tractor providing rotational power to an implement by means of a primary PTO drive shaft

See Figure 2.

3.2.2**power input connection****PIC**

first power input connection, in the form of a shaft on the implement, to which a primary PTO drive shaft is connected

See Figure 2.

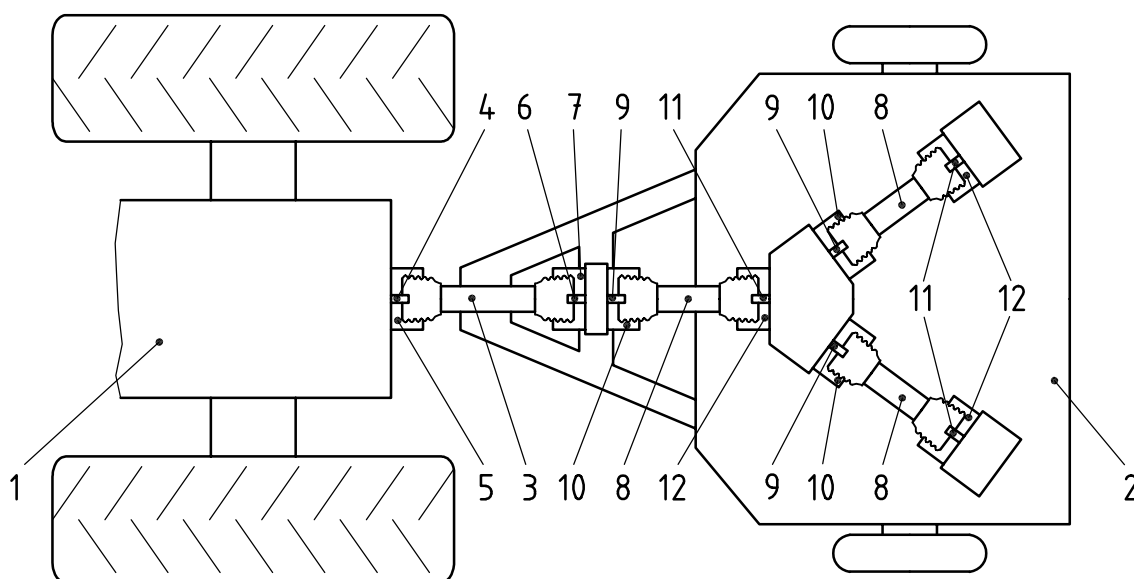
**Key**

1	tractor	7	PIC guard
2	implement	8	secondary PTO drive shaft
3	primary PTO drive shaft	9	SPTO
4	PTO	10	SPTO guard
5	PTO master shield	11	SPIC
6	PIC	12	SPIC guard

Figure 2 — Example of arrangement of PTO drive shafts

3.2.3
secondary power take-off
SPTO

external shaft on the implement drive line providing rotational power to parts of the implement by means of a secondary PTO drive shaft

See Figure 2.

3.2.4
secondary power input connection
SPIC

secondary power input connection as a shaft on the implement to which a secondary PTO drive shaft is connected

See Figure 2.

3.3
closed length

⟨PTO drive shaft⟩ distance between the centres of the outermost journal cross-assemblies of the shaft as specified by the manufacturer, when the PTO drive shaft is fully closed

3.4
extended length

⟨PTO drive shaft⟩ distance between the centres of the outermost journal cross-assemblies of the shaft when the PTO drive shaft is extended to the maximum operational length as specified by the manufacturer

3.5
universal joint

mechanical device which can transmit torque and/or rotational motion from one shaft to another at fixed or varying angles of intersection of the shaft axes

3.6
wide-angle constant velocity universal joint

constant-velocity joint allowing operation with an articulation generally higher than 50°, while motion is transmitted uniformly

3.7
overrun device

device that permits the transmission of motion in only one direction, from the tractor towards the implement

See Figure 3.

NOTE It is normally used with a recipient machine having high-value inertia.

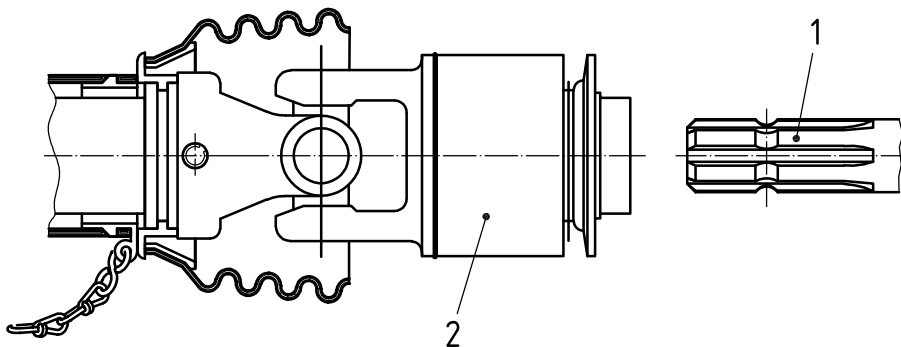

Key

- 1 PIC
- 2 overrun device

Figure 3 — Example of overrun device

3.8**torque limiter**

device that cuts or limits the transmission of motion between tractor and implement when the torque reaches a prefixed value

See Figure 4.

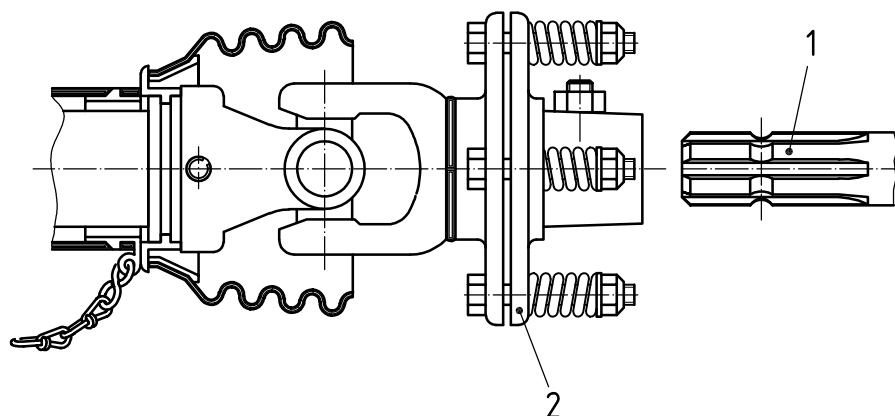
**Key**

- 1 PIC
- 2 torque limiter

Figure 4 — Example of torque limiter

3.9**non-rotating PTO drive shaft guard**

PTO drive shaft guard attached to the shaft by bearings, designed to be able to be held stationary by a restraining system while the shaft is rotating

3.10**PIC [SPTO] [SPIC] guard**

guard, fixed on the implement, which fully covers the PIC, SPTO and SPIC

3.11**restraining system**

part of the PTO drive shaft guard which prevents rotation of the guard when the PTO drive shaft rotates

See Figure 5.

3.12**rotating PTO drive shaft guard**

PTO drive shaft guard attached to the shaft by bearings, designed to be able to rotate with the shaft except when it comes into contact with some other object

3.13**maximum static torsional load**

static load limit without damage or permanent deformation of components

3.14**maximum dynamic torsional load**

dynamic load limit without damage or permanent deformation of components

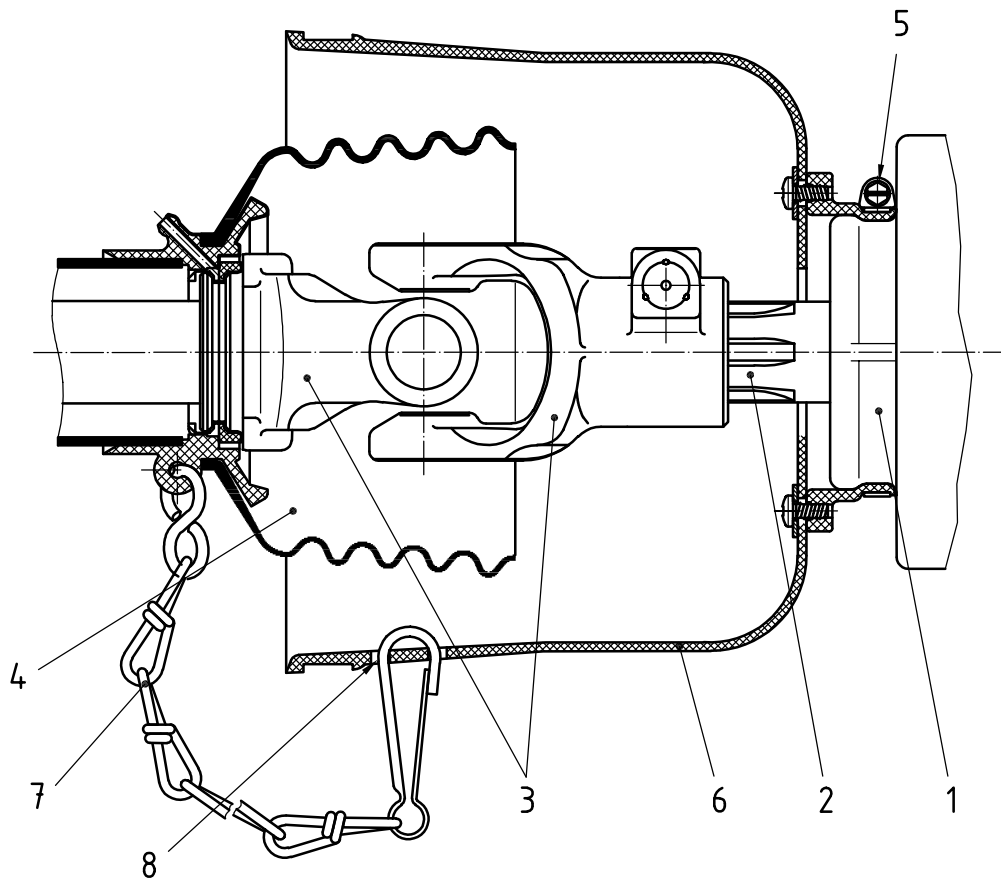

a) Restraining member between primary PTO drive shaft guard and PIC guard

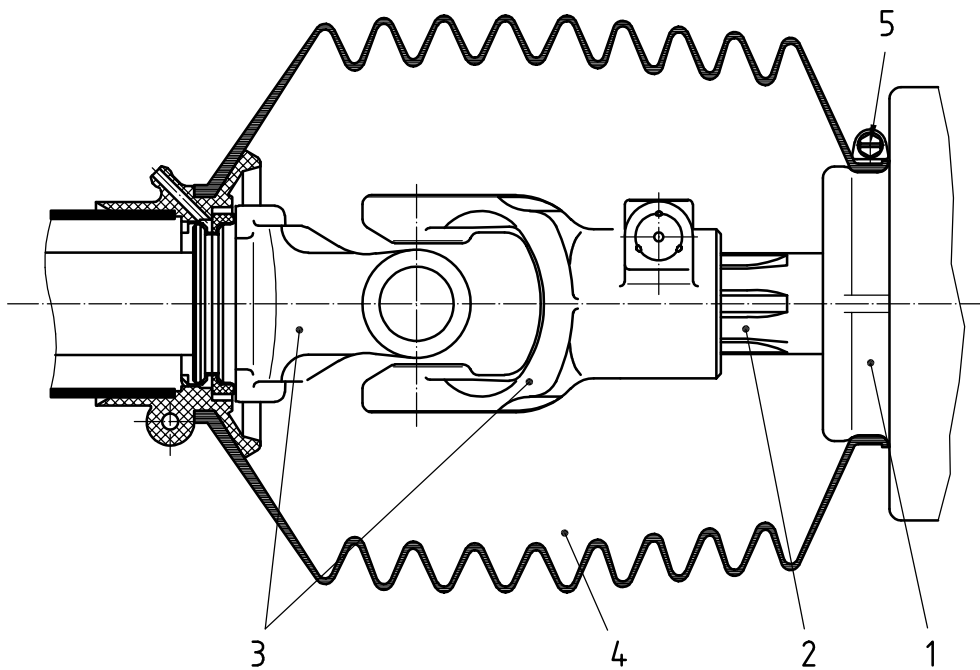

b) Clamped guard cone of primary PTO drive shaft guard on implement

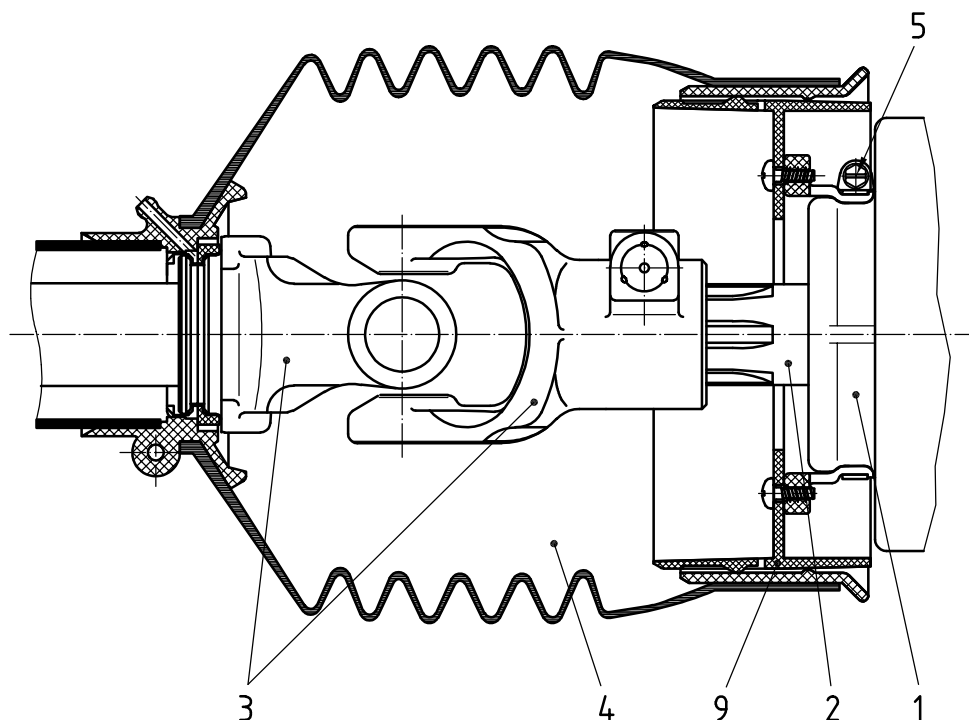

c) Clamped guard adapter between primary PTO drive shaft guard and implement

Key

1	implement	6	PIC guard
2	PIC	7	restraining member (see also Figure 1 [23])
3	universal joint	8	fixing point/hole for restraining member
4	guard cone of PTO drive shaft	9	guard adapter
5	clamping device on implement		

Figure 5 — Examples of restraining systems on implements

4 Manufacturing requirements

4.1 General

PTO drive shafts shall meet the rated values and test criteria defined by the manufacturer in the manufacturer's technical documentation for the maximum static and maximum dynamic torsional loads in accordance with 4.2 and 4.3.

4.2 Maximum static torsional loads for PTO drive shafts

4.2.1 Joints

With zero angularity, universal joints and wide-angle universal joints shall withstand, without failure occurring, the maximum static torque defined by the manufacturer in the manufacturer's technical documentation. Failure is defined as any break, crack or permanent deformation representing a change in the slope of the torque deflection curve greater than 50 %.

4.2.2 Telescopic members

Telescopic members between universal joints shall withstand, without failure occurring, the maximum static torque value defined by the manufacturer in the manufacturer's technical documentation. Failure is defined as any break, crack or permanent deformation exceeding 1° per 305 mm of length. This does not apply to torque limiters used between joint centres.

4.3 Maximum dynamic torsional loads for PTO drive shafts

Yokes, cross and bearing assemblies and telescopic members shall operate under a constant torque and joint angle and should reach under those conditions, without failure occurring, the minimum life defined by the manufacturer in the manufacturer's technical documentation. The failure rate of the journal cross assemblies and bearing shall be less than 10 %. It shall be verified by determining the temperature of the needle cups. A temperature exceeding + 120 °C shall be regarded as a failure. Failure is also any break, crack or permanent deformation on all components.

4.4 PTO/PIC yoke and SPTO/SPIC yokes

4.4.1 General

The PTO/SPTO and PIC/SPIC yokes/overrun devices and/or torque limiters shall have locking devices to prevent axial displacement. Any locking device shall withstand at least the thrust forces given in Table 1.

4.4.2 PTO yoke spline dimensions

The PTO yoke on the primary PTO drive shaft shall have spline dimensions in accordance with ISO 500-3.

4.4.3 PIC/SPTO/SPIC yoke spline dimensions

The PIC yoke on the primary PTO drive shaft or SPTO/SPIC yokes on secondary PTO drive shafts, which can be connected to a PIC, SPTO or SPIC, should have spline dimensions in accordance with ISO 500-3, including cases where an overrun device and/or torque limiter is used.

For future implement designs, only the spline dimensions according to ISO 500-3 should be used.

4.5 PTO drive shaft telescopic members

4.5.1 Phasing

Provisions shall be made in the telescopic members to assure correct phasing of universal joints as specified by the manufacturer.

4.5.2 Thrust force

The tractor PTO and PIC/SPTO/SPIC shall be designed to accept drive shaft telescopic thrust force values in accordance with Table 1. The bending force on the tractor PTO and PIC/SPTO/SPIC is dependent on the drive shaft thrust forces and length to which the force is applied. Values are based on greased telescopic members per the manufacturer's instructions.

NOTE A poorly maintained drive shaft can impose thrust forces a factor of over 4 times those given in Table 1.

Table 1 — Drive shaft telescopic thrust forces

Drive shaft power kW	PTO type ^a	Max. static thrust force in both directions (pull and push) kN
< 48	1 + 2	± 9
48 to 115	1 + 2	± 12
> 92	3	± 18
^a See ISO 500-1.		

4.6 Lubrication requirements

4.6.1 Lubrication access

Where lubricating applications are necessary, if the universal joints, the bearings between the shaft and guard and the telescopic members are provided with lubricating nipples, these shall be easily lubricated, e.g. by direct access to all the nipples, or by moving parts of the guard, provided that clear instructions are given by the manufacturer specifying that the guard shall be opened only by means of a tool and the resetting of the guard is possible without the use of the tool.

4.6.2 Lubrication holes

Where the lubricating operations require holes to be present in the drive shaft guard, the greatest dimension shall be ≤ 30 mm.

5 Safety requirements

5.1 General requirements

The PTO drive shaft guards shall be designed to prevent contact with the moving components of the PTO drive shaft, with the PTO drive shaft being operated in accordance with the instruction handbook.

No device (e.g. adapters) shall be installed between the tractor PTO and the primary PTO drive shaft.

If there is an accessory, e.g. a torque limiter and/or an overrun device, on the primary PTO drive shaft, it shall be positioned only on the PIC side of the primary PTO drive shaft (see Figures 3 and 4). A marking on the primary PTO drive shaft guard shall indicate the end of the primary PTO drive shaft that is to be fitted to the tractor or self-propelled machine (see Figure 12).

Where allowed by regional or national legislation, an accessory such as a torque limiter and/or an overrun device may be positioned on the tractor PTO side of the primary PTO drive shaft.

On secondary PTO drive shafts, an accessory such as a torque limiter and/or an overrun device may be positioned on both ends of the shafts. No marking is required.

Information for the use of fixing points (e.g. a 16 mm diameter hole) shall be provided in the instruction handbook for the restraining system (see Figure 5).

If regional or national legislation allows rotating PTO drive shaft guards, then a restraining system is not needed.

The implement shall be supplied with a support for the primary PTO drive shaft for keeping it in the storage position when uncoupled from the tractor PTO. This support shall not be the device used to prevent the rotation of the primary PTO drive shaft guard. Information for the use of the support shall be given in the instruction handbook.

In the instruction handbook (see 6.1), the manufacturer shall provide recommendations for proper application and any information limiting the use of the PTO drive shaft and its guards, including operating data and warnings against misuse. Information about requirements of the support (e.g. form, type, position etc.) for the PTO drive shaft and, if present, the restraining system, shall also be provided. A sign illustrating the need to read the instruction handbook shall be provided on the PTO drive shaft guard (see 6.2).

A sign shall be provided at a prominent location on the PTO-powered implement, near its PIC, specifying the nominal operating speed and the direction of rotation of the PTO drive shaft.

Information on how to modify the PTO drive shaft length shall be included in the instruction handbook.

5.2 Overlap between tractor master shield and primary PTO drive shaft guard

5.2.1 Universal joint

The primary PTO drive shaft guard cone shall cover the drive shaft at least up to the end of the inner yoke of the universal joint in order to ensure sufficient overlap between tractor master shield and primary PTO drive shaft guard (Figure 1, Item 11). See Table 2 for the value of dimension *c* as shown in Figure 6.

The dimension, *c*, shall be measured in straight line position of the primary PTO draft shaft.

Table 2 — Dimension *c* for primary PTO drive shaft

Dimensions in millimetres

PTO type	<i>c</i> max.
1	80
2	80
3	90

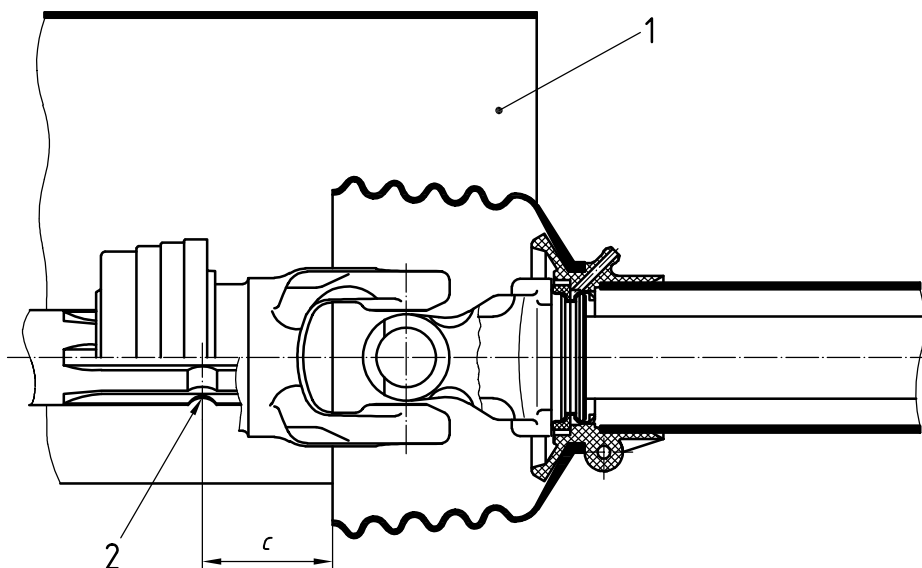

Key

- 1 master shield of tractor PTO
- 2 axis of locking device

Figure 6 — Guarding of universal joints on primary PTO drive shafts on tractor side

5.2.2 Wide-angle universal joint

The primary PTO drive shaft shall be guarded in the straight-line position at least up to the end of the outer joint of the double yoke in order to ensure sufficient overlap between tractor master shield and PTO drive shaft guard (Figure 1, Item 15). See Table 2 for dimension c as shown in Figure 7.

Dimensions in millimetres

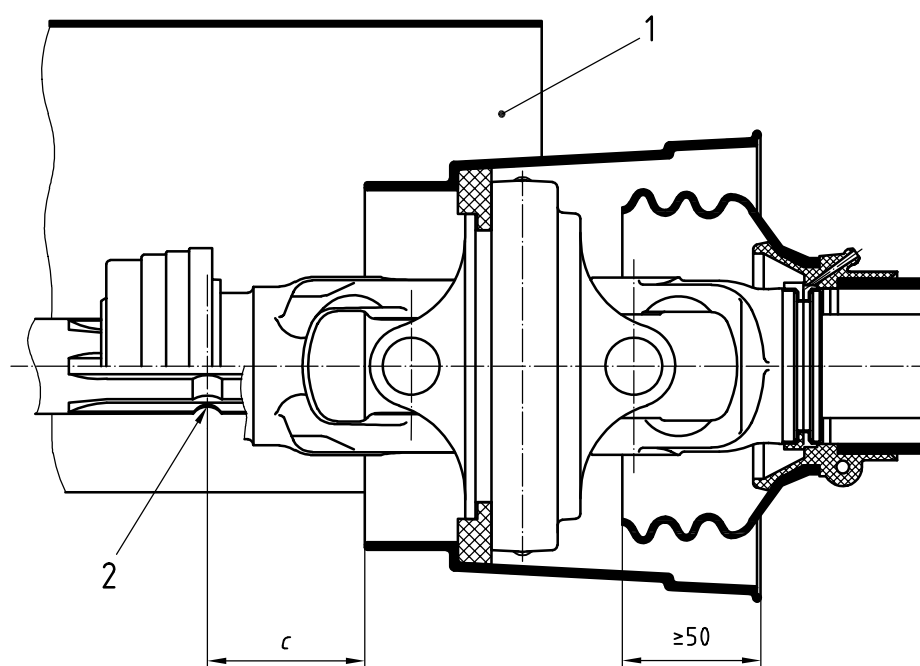

Key

- 1 master shield of tractor PTO
- 2 axis of the locking device

Figure 7 — Guarding of wide-angle universal joints on primary PTO drive shafts on tractor side

5.3 Guarding of PIC, SPTO and SPIC

5.3.1 PIC guard

The PIC guard shall be so constructed and attached to the implement such that, in conjunction with the primary PTO drive shaft guard, it encloses the primary PTO drive shaft as well as the PIC. Strength requirements shall be in accordance with ISO 4254-1.

The straight-line overlap of the primary PTO drive shaft guard cone with PIC guard shall be not less than 50 mm if a guard design is used as shown in Figures 8 and 9. This minimum overlap shall also apply when using clutches or other elements.

NOTE Owing to great joint angle requirements in combination with the use of a torque limiter and/or overrun device, it is not always possible to cover the primary PTO drive shaft guard cone at least up to the end of the inner yoke of the universal joint (see Figure 9).

If the PIC guard or portion of the guard requires movement to facilitate attachment, servicing, or storage of the primary PTO drive shaft, it shall

- be easy to open and close,
- remain attached via a hinge, slide, linkage, tether or other suitable means, and
- include a convenient and effective means to keep it closed.

The movable portion of the guard shall be resistant to unintentional movement when in the operating position.

Dimensions in millimetres

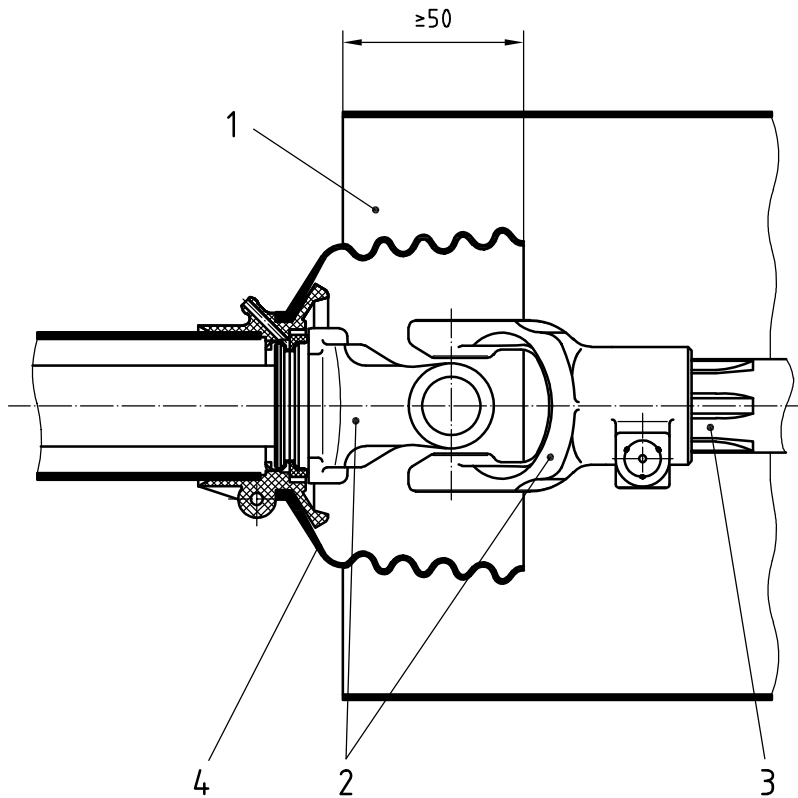

Key

- 1 PIC guard
- 2 universal joint
- 3 PIC
- 4 guard cone of primary PTO drive shaft

Figure 8 — Guarding of primary PTO drive shafts and PIC

Dimensions in millimetres

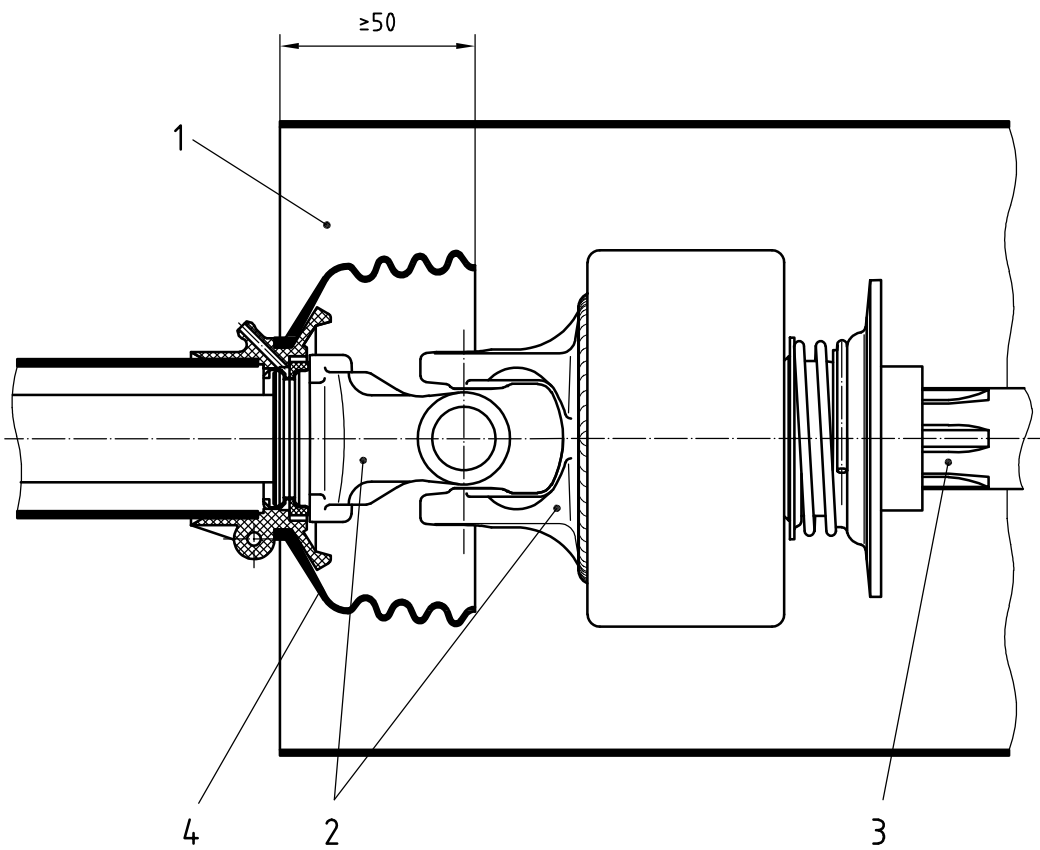

Key

- 1 PIC guard
- 2 universal joint with overrun device or torque limiter
- 3 PIC
- 4 guard cone of primary PTO drive shaft

Figure 9 — Guarding of primary PTO drive shafts equipped with torque limiter or overrun device and PIC

For mounting the primary PTO drive shaft to the PIC and for articulation requirements, an opening of 150 mm maximum between guard cone of primary PTO drive shaft and PIC guard is acceptable (see Figure 10).

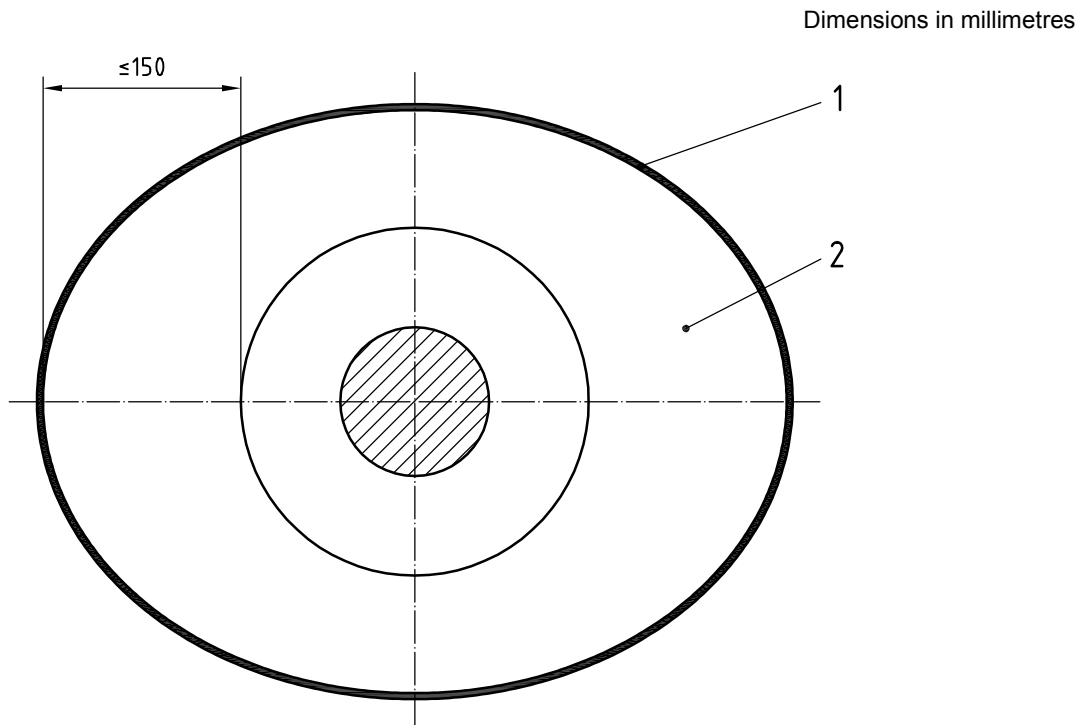

Key

- 1 PIC guard
- 2 guard cone of primary PTO drive shaft

Figure 10 — Opening allowed between guard cone of primary PTO drive shaft and PIC guard

5.3.2 SPTO guard and SPIC guard

If implements are equipped with secondary PTO drive shafts that are not guarded by location, the requirements of 5.3.1 shall be fulfilled for SPTO guards and SPIC guards in conjunction with secondary PTO drive shaft guards.

5.4 Wide-angle universal guard requirements

When a wide-angle universal joint is guarded by means of a separate guard independent of the guard of the other parts of the PTO drive shaft (Figure 1, Item 22), the guarding of this wide-angle joint shall be ensured by taking all of the following measures.

- At the maximum angular position of the rotating drive shaft, as specified by the manufacturer in the instruction handbook, the opening resulting from the angular movement shall not be more than 30 mm (see Figure 11). This requirement shall be verified by the use of a 31 mm diameter rod: if the rod can be inserted into the opening without being in contact with the guards on both sides then the opening is too large to be acceptable.
- There shall be an overlap between the separate guard and the guard cone, viewed perpendicular to the axis of the PTO drive shaft assembly when in the maximum angular position (see Figure 11).
- The overlap between the separate guard and the guard cone shall be at least 50 mm, with the PTO drive shaft in the straight-line position (see Figure 7). Where the opening between the PTO drive shaft guard and the wide angle guard does not exceed 4 mm at any angular position up to the maximum, then this 50 mm overlap may be reduced to 10 mm in the straight-line position.

Dimensions in millimetres

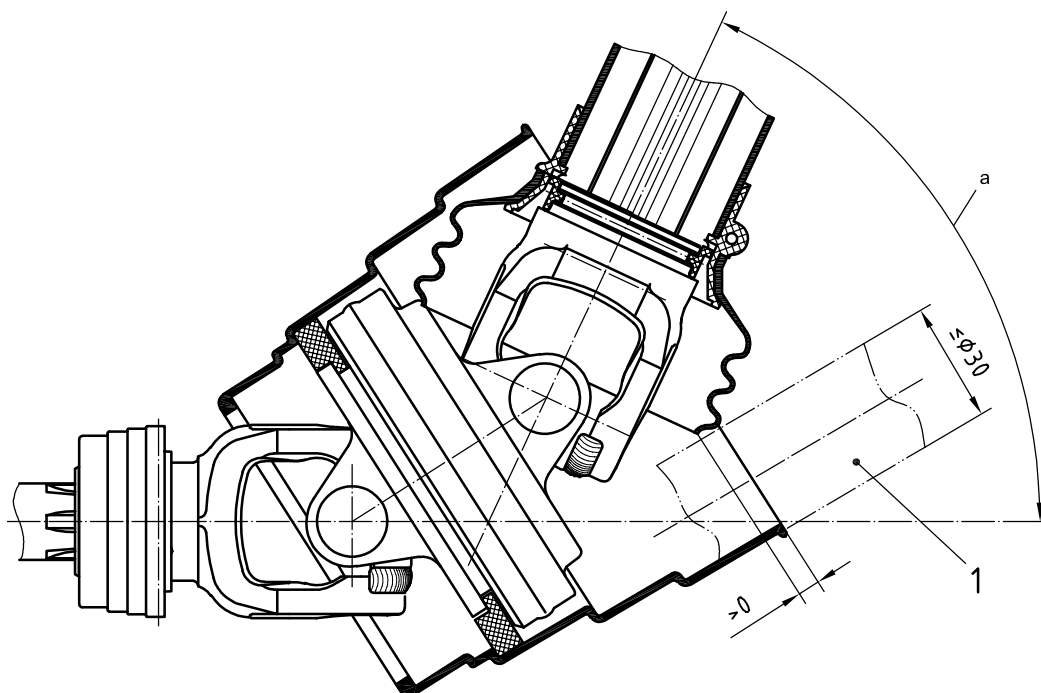
**Key**1 checking gauge $\varnothing 31$

a Maximum joint angle.

Figure 11 — Guarding of wide-angle universal joint at maximum joint angle**5.5 PTO drive shaft guard****5.5.1 General**

The PTO drive shaft guards shall comply with the acceptance criteria according to ISO 5674.

The PTO drive shafts and their guards shall be so designed that they cannot be used as a step. When necessary, a separate step shall be built to guide access on the machine.

The guard shall be designed so that it cannot be detached from the PTO drive shaft without the use of a tool.

By design, it shall be possible for the user to replace the guard by following the instructions given in the instruction handbook.

5.5.2 Restraining system

Non-rotating PTO drive shaft guards shall be provided with a restraining system (see Figure 5) to prevent the guard rotating with the shaft. The member(s) of the restraining system shall be securely attached to the guard and provided with a fitting that will enable them to be attached to a stationary part of the machine without becoming detached without an intended action.

EXAMPLE Hook with a self-closing spring or a shackle [see Figure 5, a)].

5.6 Locking device on PTO yoke

The locking system of the PTO yoke and the yoke itself shall have no feature which could cause entanglement (e.g. by collar design as shown in Figure 1).

5.7 Locking device on PIC yoke

If the implement end of the primary PTO drive shaft can be readily attached to the tractor PTO, the locking system of the PIC yoke shall meet the same requirements as the locking system for the PTO yoke, except in the case where a marking on the guard indicates the end of the primary PTO drive shaft that is to be fitted to the tractor or the self-propelled machine (see Figure 12).

5.8 Stationary PTO driven implements

Information on the use of stationary PTO driven implements shall be given in the instruction handbook.

5.9 Safety signs

A sign or pictorial on the PTO drive shaft guard should specify that operation without proper guarding is not allowed.

A safety sign shall be provided on the PTO drive shaft guard specifying the necessity to read the instruction handbook (see Figure 13 for an example).

6 Information for use

6.1 Instruction handbook

Comprehensive instructions and information on maintenance, transport and safe use, a safe system of working, extra precautions and special equipment shall be provided by the drive-line or implement manufacturer in the instruction handbook.

In particular, the following points shall be emphasized:

- a) explanation of any symbols, signs and markings used;
- b) instructions on putting into service, including, if necessary, how to cut the guard and the shaft to the correct length to ensure that the necessary overlap of telescopic members and guard tubes as specified by the manufacturer is maintained under all conditions of use;
- c) instructions on the maintenance, lubrication and repair of the guard, shaft and clutches (overrun device and/or torque limiter), if any;
- d) foreseen uses of the guard and the shaft, including the maximum allowable angles in use from the straight-line position and the relationship between the size of the PTO drive shaft and the type of master shield or PIC/SPIC guard;
- e) that the PTO drive shaft shall not be used without a guard or with a damaged guard or without using the restraining member(s) correctly;
- f) the need to use a support for the PTO drive shaft, when it is uncoupled from the tractor PTO or self-propelled machine PTO, which is different from the restraining member(s), and instruction not to use the restraining member for this purpose;
- g) the necessity to replace any worn or damaged part by an appropriate service part and a warning against use of non-compatible parts;

- h) how to replace the PTO drive shaft guard or its components;
- i) how to use and attach a restraining system;
- j) the necessity to check in the instruction handbook of the implement whether the use of devices such as a torque limiter and/or overrun device is required, and, if so, how they are to be fitted;
- k) warning against using the PTO drive shaft, its guard or the PIC guard as a step;
- l) the nominal power in kilowatts to be transmitted by the PTO drive shaft and the nominal speed of rotation;
- m) instructions for fitting the PTO drive shaft onto the PTO of the tractor or self-propelled machine and PIC of the implement;
- n) if necessary, instructions regarding securing of the tractor three-point hitch lower links in a suitable position for trailed machines, and removal of the drawbar of the tractor for mounted or semi-mounted machines if needed to avoid damage to the PTO drive shaft guard;
- o) limitation of the maximum recommended articulation angle between tractor and implement, if not controlled by design;
- p) how to use adapters;
- q) the use of implements stationary and not connected to a tractor or self-propelled machine, including either a warning not to operate the implement stationary without having it coupled to a tractor, or instruction to use it together with a special mechanical connection provided for the purpose to prevent separation of the tractor and the implement during operation.

6.2 Marking and safety signs

Safety signs, if used, shall be in accordance with ISO 11684.

Where needed, an example for marking on the primary PTO drive shaft guard shall indicate the end of the primary PTO drive shaft that is to be linked to the PTO of the tractor or the self-propelled machine (see Figure 12).

See also Figure 13.

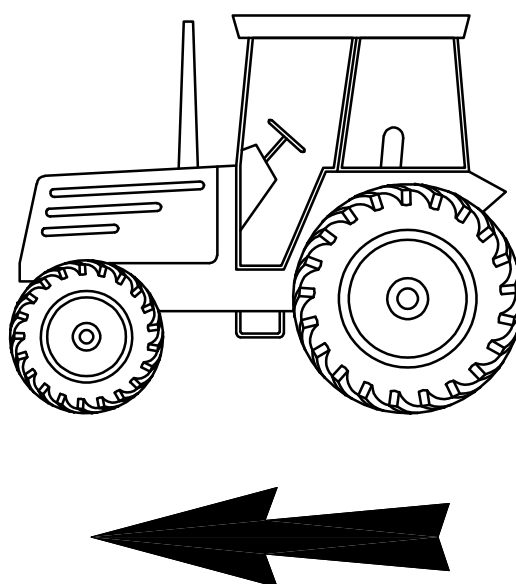

Figure 12 — Example pictogram marking end of primary PTO drive shaft to be fixed to tractor PTO

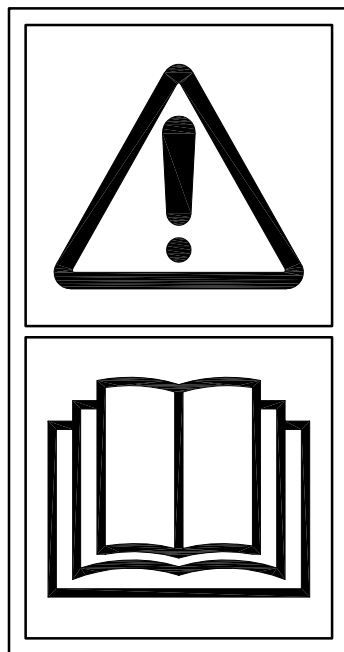

Figure 13 — Example of pictogram for “Read instruction handbook”

When possible, PTO drive shaft guards or components shall be marked such that they can be identified.

When required by regional or national legislation, the following minimum information shall be marked legibly and indelibly:

- name and address of the manufacturer;
- designation of series or type;
- year of construction.

6.3 Spare parts list

The spare parts list of the PTO drive shaft and of the guard should be in the technical documentation of the implement with which the drive shaft is used.

Bibliography

- [1] ISO 500-1:2004, *Agricultural tractors — Rear-mounted power take-off types 1, 2 and 3 — Part 1: General specifications, safety requirements, dimensions for master shield and clearance zone*

