

---

---

**Tool holders with rectangular shank for  
indexable inserts —**

**Part 1:  
General survey, correlation and  
determination of dimensions**

*Porte-plaquette à queue rectangulaire pour plaquettes amovibles —  
Partie 1: Vue d'ensemble, corrélation et détermination des dimensions*



**PDF disclaimer**

This PDF file may contain embedded typefaces. In accordance with Adobe's licensing policy, this file may be printed or viewed but shall not be edited unless the typefaces which are embedded are licensed to and installed on the computer performing the editing. In downloading this file, parties accept therein the responsibility of not infringing Adobe's licensing policy. The ISO Central Secretariat accepts no liability in this area.

Adobe is a trademark of Adobe Systems Incorporated.

Details of the software products used to create this PDF file can be found in the General Info relative to the file; the PDF-creation parameters were optimized for printing. Every care has been taken to ensure that the file is suitable for use by ISO member bodies. In the unlikely event that a problem relating to it is found, please inform the Central Secretariat at the address given below.



**COPYRIGHT PROTECTED DOCUMENT**

© ISO 2010

All rights reserved. Unless otherwise specified, no part of this publication may be reproduced or utilized in any form or by any means, electronic or mechanical, including photocopying and microfilm, without permission in writing from either ISO at the address below or ISO's member body in the country of the requester.

ISO copyright office  
Case postale 56 • CH-1211 Geneva 20  
Tel. + 41 22 749 01 11  
Fax + 41 22 749 09 47  
E-mail [copyright@iso.org](mailto:copyright@iso.org)  
Web [www.iso.org](http://www.iso.org)

Published in Switzerland

# Contents

Page

|  |           |
|--|-----------|
| Foreword .....   | iv        |
| <b>1 Scope .....</b>   | <b>1</b>  |
| <b>2 Normative references .....</b>  | <b>1</b>  |
| <b>3 Survey .....</b>  | <b>2</b>  |
| <b>4 Dimensions .....</b>  | <b>6</b>  |
| 4.1 Cross-section and length, $l_1$ .....  | 6         |
| 4.2 Head length, $l_2$ .....   | 7         |
| 4.3 Dimension, $f$ .....   | 7         |
| <b>5 Determination of dimensions .....</b>   | <b>8</b>  |
| 5.1 Cutting edge corners .....   | 8         |
| 5.2 Corner radius, $r_E$ , of the master indexable inserts .....   | 9         |
| 5.3 Length, $l_1$ .....  | 10        |
| 5.4 Dimension $f$ .....  | 10        |
| 5.5 Height, $h_1$ .....  | 11        |
| 5.6 Tolerances .....   | 11        |
| 5.7 Dimension, $a$ .....   | 11        |
| 5.8 Correction values, $x$ and $y$ .....   | 11        |
| <b>Annex A (informative) Relationship between designations in ISO 5610 (all parts)<br/>and ISO/TS 13399-2 and ISO/TS 13399-3 .....</b> | <b>15</b> |
| <b>Bibliography .....</b>  | <b>16</b> |

## Foreword

ISO (the International Organization for Standardization) is a worldwide federation of national standards bodies (ISO member bodies). The work of preparing International Standards is normally carried out through ISO technical committees. Each member body interested in a subject for which a technical committee has been established has the right to be represented on that committee. International organizations, governmental and non-governmental, in liaison with ISO, also take part in the work. ISO collaborates closely with the International Electrotechnical Commission (IEC) on all matters of electrotechnical standardization.

International Standards are drafted in accordance with the rules given in the ISO/IEC Directives, Part 2.

The main task of technical committees is to prepare International Standards. Draft International Standards adopted by the technical committees are circulated to the member bodies for voting. Publication as an International Standard requires approval by at least 75 % of the member bodies casting a vote.

Attention is drawn to the possibility that some of the elements of this document may be the subject of patent rights. ISO shall not be held responsible for identifying any or all such patent rights.

ISO 5610-1 was prepared by Technical Committee ISO/TC 29, *Small tools*, Subcommittee SC 9, *Tools with cutting edges made of hard cutting materials*.

This first edition of ISO 5610-1, together with ISO 5610-2, ISO 5610-3, ISO 5610-4, ISO 5610-5, ISO 5610-6, ISO 5610-7, ISO 5610-8, ISO 5610-9, ISO 5610-10, ISO 5610-11, ISO 5610-12, ISO 5610-13, ISO 5610-14 and ISO 5610-15, cancels and replaces ISO 5610:1998.

ISO 5610 consists of the following parts, under the general title *Tool holders with rectangular shank for indexable inserts*:

- *Part 1: General survey, correlation and determination of dimensions*
- *Part 2: Style A*
- *Part 3: Style B*
- *Part 4: Style D*
- *Part 5: Style F*
- *Part 6: Style G*
- *Part 7: Style J*
- *Part 8: Style K*
- *Part 9: Style L*
- *Part 10: Style N*
- *Part 11: Style R*
- *Part 12: Style S*
- *Part 13: Style T*
- *Part 14: Style H*
- *Part 15: Style V*

# Tool holders with rectangular shank for indexable inserts —

## Part 1:

# General survey, correlation and determination of dimensions

## 1 Scope

This part of ISO 5610 specifies tool holders with rectangular shank for indexable inserts and specifies their styles in relation to their dimensions according to ISO 5610-2, ISO 5610-3, ISO 5610-4, ISO 5610-5, ISO 5610-6, ISO 5610-7, ISO 5610-8, ISO 5610-9, ISO 5610-10, ISO 5610-11, ISO 5610-12, ISO 5610-13, ISO 5610-14 and ISO 5610-15.

These tool holders are primarily intended for indexable inserts made of hardmetal, ceramic or other cutting materials intended to be mounted by clamping and used for turning operations. This part of ISO 5610 is general and is intended to be used with ISO 5610-2, ISO 5610-3, ISO 5610-4, ISO 5610-5, ISO 5610-6, ISO 5610-7, ISO 5610-8, ISO 5610-9, ISO 5610-10, ISO 5610-11, ISO 5610-12, ISO 5610-13, ISO 5610-14 and ISO 5610-15.

## 2 Normative references

The following referenced documents are indispensable for the application of this document. For dated references, only the edition cited applies. For undated references, the latest edition of the referenced document (including any amendments) applies.

ISO 5608, *Turning and copying tool holders and cartridges for indexable inserts — Designation*

ISO 5610-2, *Tool holders with rectangular shank for indexable inserts — Part 2: Style A*

ISO 5610-3, *Tool holders with rectangular shank for indexable inserts — Part 3: Style B*

ISO 5610-4, *Tool holders with rectangular shank for indexable inserts — Part 4: Style D*

ISO 5610-5, *Tool holders with rectangular shank for indexable inserts — Part 5: Style F*

ISO 5610-6, *Tool holders with rectangular shank for indexable inserts — Part 6: Style G*

ISO 5610-7, *Tool holders with rectangular shank for indexable inserts — Part 7: Style J*

ISO 5610-8, *Tool holders with rectangular shank for indexable inserts — Part 8: Style K*

ISO 5610-9, *Tool holders with rectangular shank for indexable inserts — Part 9: Style L*

ISO 5610-10, *Tool holders with rectangular shank for indexable inserts — Part 10: Style N*

ISO 5610-11, *Tool holders with rectangular shank for indexable inserts — Part 11: Style R*

ISO 5610-12, *Tool holders with rectangular shank for indexable inserts — Part 12: Style S*

ISO 5610-13, *Tool holders with rectangular shank for indexable inserts — Part 13: Style T*

ISO 5610-14, *Tool holders with rectangular shank for indexable inserts — Part 14: Style H*

ISO 5610-15, *Tool holders with rectangular shank for indexable inserts — Part 15: Style V*

### 3 Survey

The survey of the tool holders with rectangular shank cross-section shall be as given in Table 1. The tool holders with rectangular shank cross-section and their corresponding letter symbols and shank sizes shall be in accordance with ISO 5610-2, ISO 5610-3, ISO 5610-4, ISO 5610-5, ISO 5610-6, ISO 5610-7, ISO 5610-8, ISO 5610-9, ISO 5610-10, ISO 5610-11, ISO 5610-12, ISO 5610-13, ISO 5610-14 and ISO 5610-15.

The designation code shall be as given in ISO 5608.

**Table 1 — Tool holders with rectangular shanks**

Dimensions in millimetres

| Style of tool holder | Illustration  | Symbols for the cross-section |      |      |      |      |      |      |      |      |      |      | Dimensions in |
|----------------------|---|-------------------------------|------|------|------|------|------|------|------|------|------|------|---------------|
|                      |   | $h_2 \times b$                |      |      |      |      |      |      |      |      |      |      |               |
|                      |   | 0808                          | 1010 | 1212 | 1616 | 2020 | 2525 | 3225 | 3232 | 4032 | 4040 | 5050 |               |
| A                    |    |                               | •    |      |      |      |      |      |      |      |      |      | ISO 5610-2    |
|                      |  |                               |      | •    | •    | •    | •    | •    | •    |      | •    |      |               |
| B                    |  | •                             | •    |      |      |      |      |      |      |      |      |      | ISO 5610-3    |
|                      |  |                               |      | •    | •    | •    | •    | •    | •    |      | •    | •    |               |
| D                    |  |                               | •    | •    | •    | •    | •    | •    |      |      |      |      | ISO 5610-4    |
|                      |  | •                             | •    | •    | •    | •    | •    | •    | •    |      | •    |      |               |

Table 1 (continued)

| Style of tool holder | Illustration | Symbols for the cross-section |      |      |      |      |      |      |      |      |      |             | Dimensions in |
|----------------------|--------------|-------------------------------|------|------|------|------|------|------|------|------|------|-------------|---------------|
|                      |              | $h_2 \times b$                |      |      |      |      |      |      |      |      |      |             |               |
|                      |              | 0808                          | 1010 | 1212 | 1616 | 2020 | 2525 | 3225 | 3232 | 4032 | 4040 | 5050        |               |
| F                    |              | •                             | •    |      |      |      |      |      |      |      |      |             | ISO 5610-5    |
|                      |              |                               |      | •    | •    | •    | •    | •    | •    |      |      | •           |               |
| G                    |              | •                             | •    |      |      |      |      |      |      |      |      | ISO 5610-6  |               |
|                      |              |                               |      | •    | •    | •    | •    | •    | •    |      |      |             | •             |
| H                    |              |                               | •    | •    | •    | •    | •    | •    |      |      |      | ISO 5610-14 |               |
|                      |              |                               |      | •    | •    | •    | •    | •    |      |      |      |             |               |

Table 1 (continued)

| Style of tool holder | Illustration  | Symbols for the cross-section |      |      |      |      |      |      |      |      |      |      | Dimensions in |            |
|----------------------|---|-------------------------------|------|------|------|------|------|------|------|------|------|------|---------------|------------|
|                      |   | $h_2 \times b$                |      |      |      |      |      |      |      |      |      |      |               |            |
|                      |   | 0808                          | 1010 | 1212 | 1616 | 2020 | 2525 | 3225 | 3232 | 4032 | 4040 | 5050 |               |            |
| J                    |    | •                             | •    | •    | •    | •    | •    | •    |      |      | •    |      |               | ISO 5610-7 |
|                      |    |                               |      |      |      | •    | •    | •    |      | •    |      |      |               |            |
|                      |   |                               |      |      | •    | •    | •    | •    | •    |      |      |      |               |            |
| K                    |  | •                             | •    |      |      |      |      |      |      |      |      |      | ISO 5610-8    |            |
|                      |  |                               |      |      | •    | •    | •    | •    | •    |      | •    |      |               |            |
| L                    |  | •                             | •    | •    | •    | •    | •    | •    | •    |      | •    |      | ISO 5610-9    |            |
|                      |  | •                             | •    | •    | •    | •    | •    | •    | •    |      |      |      |               |            |

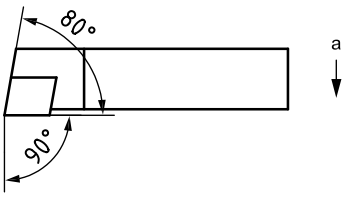
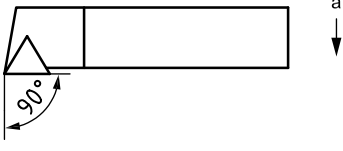
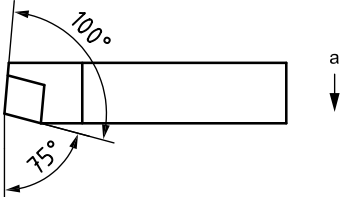
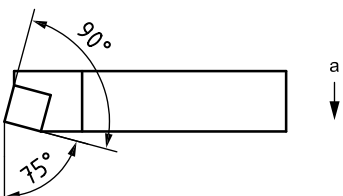
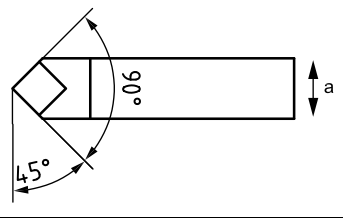
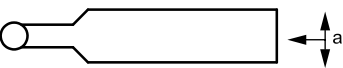

Table 1 (continued)

| Style of tool holder   | Illustration  | Symbols for the cross-section |      |      |      |      |      |      |      |      |      |      | Dimensions in |             |
|--|---|-------------------------------|------|------|------|------|------|------|------|------|------|------|---------------|-------------|
|  |   | $h_2 \times b$                |      |      |      |      |      |      |      |      |      |      |               |             |
|  |   | 0808                          | 1010 | 1212 | 1616 | 2020 | 2525 | 3225 | 3232 | 4032 | 4040 | 5050 |               |             |
| N  |    | •                             | •    | •    | •    | •    | •    | •    |      |      | •    |      | ISO 5610-10   |             |
|  |    |                               |      |      |      |      |      | •    | •    |      | •    |      |               |             |
| R  |    |                               |      |      | •    | •    | •    | •    | •    |      |      | •    | •             | ISO 5610-11 |
| S  |   | •                             | •    | •    | •    | •    | •    | •    |      |      |      |      | ISO 5610-12   |             |
|  |  |                               |      |      | •    | •    | •    | •    | •    |      |      | •    |               | •           |
|  |  | •                             | •    | •    | •    | •    | •    | •    | •    |      |      | •    |               |             |
| T  |  |                               |      |      | •    | •    | •    | •    | •    |      |      | •    | ISO 5610-13   |             |
| V  |  |                               |      |      | •    | •    | •    | •    |      |      |      |      | ISO 5610-15   |             |
| <ul style="list-style-type: none"> <li>• standardized</li> <li>blank not standardized</li> <li>a Primary direction of feed.</li> </ul> |   |                               |      |      |      |      |      |      |      |      |      |      |               |             |

© ISO 2010. All rights reserved.

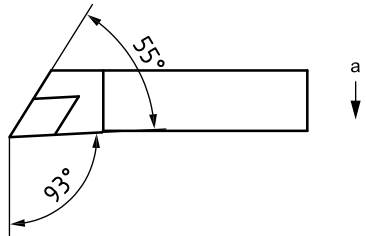
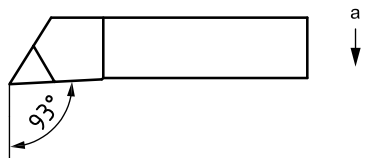
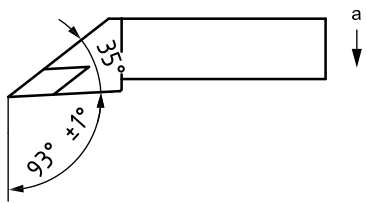
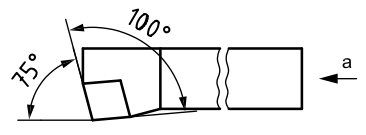
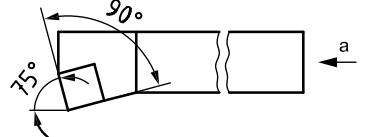
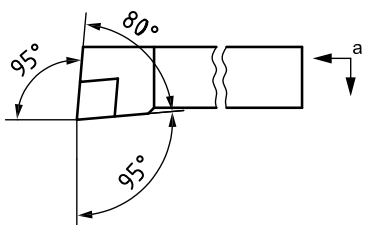
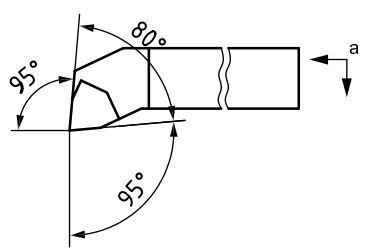
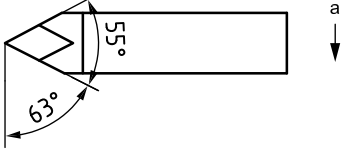
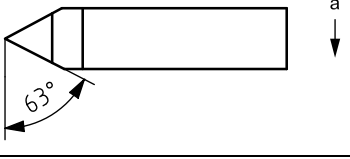
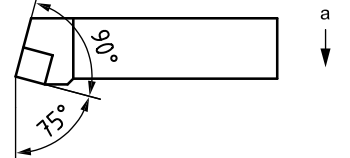
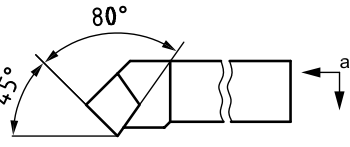
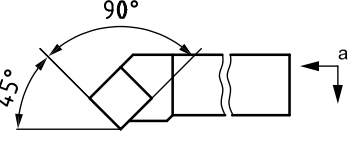
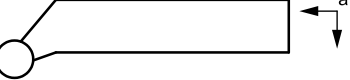
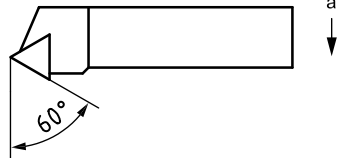
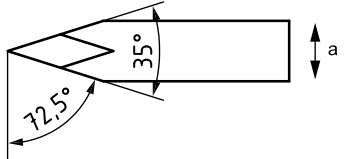
## 4 Dimensions

### 4.1 Cross-section and length, $l_1$

The dimensions of the cross-section, depending on the length,  $l_1$ , and height,  $h_1$ , of the cutting edge shall be in accordance with Figure 1 and Table 2.

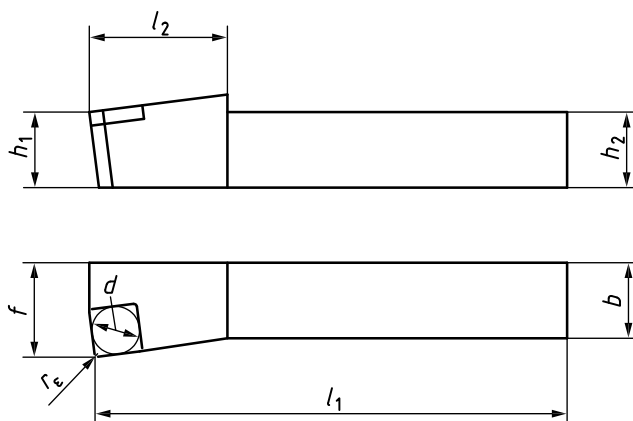

Figure 1 — Tool holder type K

Table 2 — Dimensions of the cross-section

Dimensions in millimetres

| $h_1$<br>js13 | $h_2$<br>h13 | $b^a$    |          | $l_1$ |       |
|---------------|--------------|----------|----------|-------|-------|
|               |              | h13      |          | k16   |       |
|               |              | Series 1 | Series 2 | long  | short |
| 8             | 8            | 8        | —        | 60    | 40    |
| 10            | 10           | 10       | 8        | 70    | 50    |
| 12            | 12           | 12       | 10       | 80    | 60    |
| 16            | 16           | 16       | 12       | 100   | 70    |
| 20            | 20           | 20       | 16       | 125   | 80    |
| 25            | 25           | 25       | 20       | 150   | 100   |
| 32            | 32           | 32       | 25       | 170   | 125   |
| 40            | 40           | 40       | 32       | 200   | 150   |
| 50            | 50           | 50       | 40       | 250   | —     |

<sup>a</sup> Series 1:  $b = h_2$ ; Series 2:  $b \approx 0,8 h_2$ .

#### 4.2 Head length, $l_2$

The maximum head length,  $l_2$ , depending on the diameter,  $d$ , of the inscribed circle of the indexable inserts, shall be in accordance with Figure 1 and Table 3.

The head length given in Table 3 shall not apply to tool holders with indexable inserts styles D and V.

**Table 3 — Head length**

Dimensions in millimetres

| $d$    | $l_2$<br>max. |
|--------|---------------|
| 6,35   | 25            |
| 7,94   | 28            |
| 9,525  | 32            |
| 12,7   | 36            |
| 15,875 | 40            |
| 19,05  | 45            |
| 25,4   | 50            |

#### 4.3 Dimension, $f$

The dimension,  $f$ , depending on the width,  $b$ , of the cross-section and the shape of the tool holder, shall be in accordance with Table 4.

**Table 4 — Dimension  $f$**

Dimensions in millimetres

| $b$ | $f$<br>for tool holder styles |                  |                     |                  |                  |                                       |
|-----|-------------------------------|------------------|---------------------|------------------|------------------|---------------------------------------|
|     | D, V<br>$\pm 0,25$            | N<br>$+0,5$<br>0 | B, T<br>$+0,5$<br>0 | A<br>$+0,5$<br>0 | R<br>$+0,5$<br>0 | F, G, H, J,<br>K, L, S<br>$+0,5$<br>0 |
| 8   | 4                             |                  | 7                   | 8,5              | 9                | 10                                    |
| 10  | 5                             |                  | 9                   | 10,5             | 11               | 12                                    |
| 12  | 6                             |                  | 11                  | 12,5             | 13               | 16                                    |
| 16  | 8                             |                  | 13                  | 16,5             | 17               | 20                                    |
| 20  | 10                            |                  | 17                  | 20,5             | 22               | 25                                    |
| 25  | 12,5                          |                  | 22                  | 25,5             | 27               | 32                                    |
| 32  | 16                            |                  | 27                  | 33               | 35               | 40                                    |
| 40  | 20                            |                  | 35                  | 41               | 43               | 50                                    |
| 50  | 25                            |                  | 43                  | 51               | 53               | 60                                    |

## 5 Determination of dimensions

### 5.1 Cutting edge corners

#### 5.1.1 Cutting edge corner, $K$

5.1.1.1 The specified point,  $K$ , shall be defined as follows.

Consider planes  $P_f$  (assumed working plane) and  $P_s$  (tool cutting edge plane), as defined in ISO 3002-1 for a selected point on the major cutting edge (e.g. point of tangency of major cutting edge with inscribed circle):

- a) for  $\kappa_r \leq 90^\circ$ , point  $K$  shall be defined as the intersection of plane  $P_s$ , a plane parallel to plane  $P_f$  tangent to the corner radius and a plane containing the tool face  $A_\gamma$  (see Figures 2 and 3);
- b) for  $\kappa_r > 90^\circ$ , point  $K$  shall be defined as the intersection of a plane parallel to plane  $P_f$  tangent to the corner radius, a plane perpendicular to plane  $P_f$  tangent to the corner radius and a plane containing the tool face  $A_\gamma$  (see Figures 4 and 5).

For tool holders style S, the side rake shall be equal to the back rake.

5.1.1.2 For special cases of tool holders styles D and S with round indexable inserts:

- a) for tool holders style D (see Figure 6), point  $K$  shall be defined as the intersection of
  - a plane parallel to  $P_f$  passing through the axis of the indexable insert,
  - a plane perpendicular to  $P_f$  and tangential to the cutting edge, and
  - a plane containing  $A_\gamma$ ;
- b) for tool holders style S (see Figure 7), there are two cases of point  $K$ . These shall be defined by two planes  $P_f$  in directions of two main perpendicular feeds, which are tangential to the cutting edge of the indexable insert.

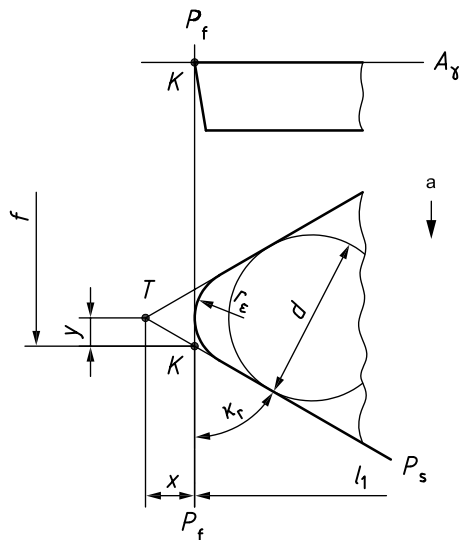

a Primary direction of feed.

**Figure 2 — Cutting edge angle  $\kappa_r \leq 90^\circ$ , with transverse feed**

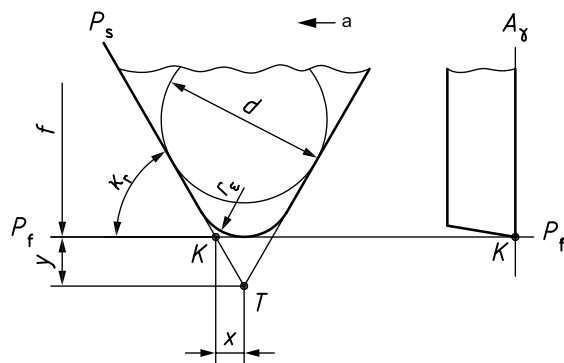

a Primary direction of feed.

**Figure 3 — Cutting edge angle  $\kappa_r \leq 90^\circ$ , with longitudinal feed**

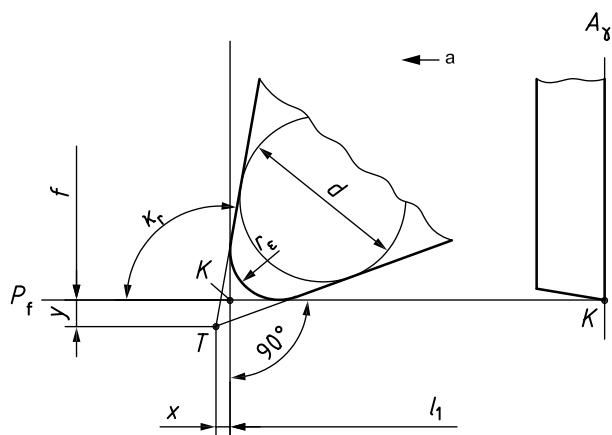

a Primary direction of feed.

**Figure 4 — Cutting edge angle  $\kappa_T > 90^\circ$ , with longitudinal feed**

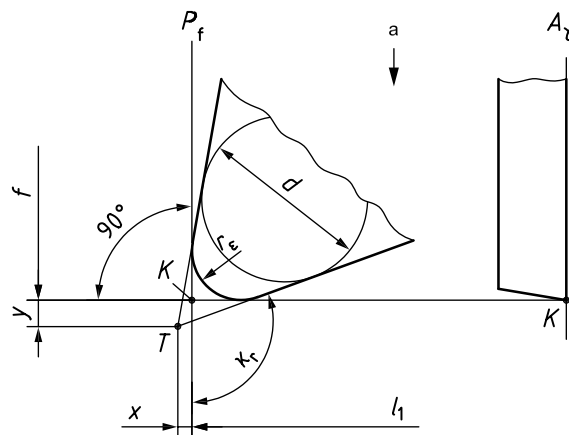

a Primary direction of feed.

**Figure 5 — Cutting edge angle  $\kappa_T > 90^\circ$ , with transverse feed**

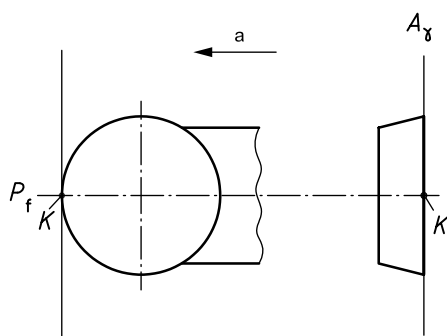

a Primary direction of feed.

**Figure 6 — Point  $K$  for tool style D with round indexable insert**

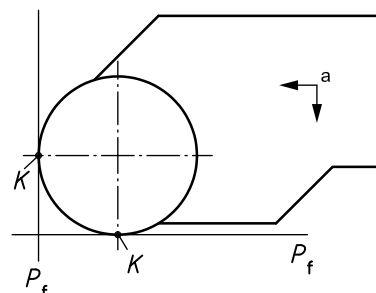

a Primary direction of feed.

**Figure 7 — Point  $K$  for tool style S with round indexable insert**

### 5.1.2 Theoretical cutting corner, $T$

The intersection of the theoretical extensions of major cutting edge and minor cutting edge shall be considered as the theoretical cutting edge corner,  $T$  (see Figures 2 to 5).

NOTE The position of the theoretical corner,  $T$ , is independent of the corner radius,  $r_e$ , of the indexable insert.

## 5.2 Corner radius, $r_e$ , of the master indexable inserts

The values of the corner radius,  $r_e$ , of the master indexable insert (master gauge) used for the definition and testing of length,  $l_1$ , dimension,  $f$ , and height,  $h_1$ , shall be in accordance with Table 5.

Table 5 — Corner radius

Dimensions in millimetres

| $d$    | $r_{\epsilon}$<br>Nominal dimension <sup>a</sup> |
|--------|--|
| 6,35   | 0,4  |
| 7,94   |  |
| 9,525  | 0,8  |
| 12,7   |  |
| 15,875 | 1,2  |
| 19,05  |  |
| 25,4   | 2,4  |

<sup>a</sup> The correction values  $x$  and  $y$  are derived from the accurate values of the corner radii  $r_{\epsilon} = 0,397$  mm, 0,794 mm, 1,191 mm and 2,381 mm, which correspond to the inch dimensions.

The corner radius,  $r_{\epsilon}$ , of the master indexable insert shall be a function of the size of the indexable insert associated to the tool holder and Table 5 it shall, therefore, be related to the diameter of the inscribed circle.

### 5.3 Length, $l_1$

The length,  $l_1$  (for values, see Table 2), shall be the distance between the specified point,  $K$ , and the shank end (see Figures 1 to 5 and the illustrations in Table 6), measured on a master indexable insert with corner radius,  $r_{\epsilon}$ , in accordance with 5.2.

For tool holders with indexable inserts with a corner radius,  $r_{\epsilon}$ , deviating from Table 5, the modified length,  $l_1$ , shall be determined with correction value  $x$  as shown in Figures 2 to 5.

The correction value  $x$  (see Table 6) corresponds to the distance, measured parallel to the shank, between the specified point,  $K$ , and the theoretical corner,  $T$ .

The modified length shall be obtained from the length,  $l_1$ , given in Table 2 and the difference between the values  $x$  for the new corner radius and the corner radius given in Table 5.

### 5.4 Dimension $f$

Dimension  $f$  (for values, see Table 4) shall be the distance between the specified point,  $K$ , and the rear backing surface of the tool holder (see Figures 1 to 5 and the illustrations in Table 6), measured on a master indexable insert with corner radius,  $r_{\epsilon}$ , in accordance with 5.2.

Exceptions to this definition are symmetrical tool holders styles D and V, for which the values given in Table 4 for dimension  $f$  shall apply to the distance measured between the theoretical cutting edge corner,  $T$ , and the rear backing surface of the tool holders (see Figures 2 and 3).

For tool holders style D, the functional dimension relating to the cutting edge corner,  $K$ , shall be either the dimension  $f+y$  or  $f-y$ , where  $y$  has to be taken from Table 6.

For tool holders with indexable inserts with a corner radius,  $r_{\epsilon}$ , deviating from Table 5, the modified dimension  $f$  shall be determined with correction value  $y$  as shown in Figures 2 to 5.

Correction value,  $y$ , corresponds to the distance between the specified point,  $K$ , and the theoretical cutting edge corner,  $T$ , measured transverse to the shank.

The modified dimension,  $f$ , shall be obtained from the value given in Table 4 and the difference between the  $y$ -values for the new corner radius and the corner radius given in Table 5.

## 5.5 Height, $h_1$

The height,  $h_1$  (for values, see Table 2), shall be the distance between the specified point,  $K$ , and the base of the tool holder (see Figure 1), measured on a master indexable insert and optional on a master shim.

## 5.6 Tolerances

The tolerances given in Tables 2 and 4 refer to length,  $l_1$ , dimension,  $f$ , and height,  $h_1$ , measured on a master indexable insert and a master shim, if applicable. Therefore, the tolerances on  $l_1$ ,  $f$  and  $h_1$  shall not include the tolerances on indexable insert and shim.

## 5.7 Dimension, $a$

### 5.7.1 General

Dimension,  $a$ , shall be related to the determination of the overall width and overall length of tool holders.

In general, the overall width corresponds to dimension  $f$  for the shank width and the overall length corresponds to dimension  $l_1$ , with the exception of tool holders of styles defined in 5.7.2 and 5.7.3.

### 5.7.2 Styles R and T

For styles R and T, the overall width of the tool holder shall be the sum of the values for  $f$  and  $a$ .

Dimension,  $a$ , is defined as the distance between the specified point,  $K$ , and the tangent to the corner radius of the indexable insert, measured parallel to the shank length (see the illustrations in Table 6).

### 5.7.3 Styles K and S

For styles K and S, the overall length of the tool holder shall be the sum of the values for  $l_1$  and  $a$ .

Dimension,  $a$ , shall be defined as the distance between the specified point,  $K$ , and the tangent on the corner radius of the indexable insert, measured perpendicular to the shank length (see the illustrations in Table 6).

### 5.7.4 Values for dimension, $a$

The values for dimension,  $a$ , shall be given in the respective dimension standards and apply to indexable inserts with corner radii in accordance with 5.2, with rake angle  $\gamma_n = 0^\circ$  and inclination angle  $\lambda_s = 0^\circ$ .

For tool holders with indexable inserts with corner radii deviating from the values given in Table 5, the modified dimension,  $a$ , shall be determined for styles R and T with correction value,  $y$ , and for styles K and S with correction value  $x$  (for values for  $x$  and  $y$ , see Table 6).

For the rake  $\gamma_n$  and cutting edge inclination  $\lambda_s$  varying between  $-6^\circ$  and  $+6^\circ$ , variations of the values for  $a$  are less than 0,1 mm and thus negligible.

## 5.8 Correction values, $x$ and $y$

The correction values,  $x$  and  $y$ , given in Table 6 shall apply to rake angle  $\gamma_n = 0^\circ$  and cutting edge inclination  $\lambda_s = 0^\circ$ . Rake angles  $\gamma_n$  and cutting edge inclinations  $\lambda_s$  varying between  $-6^\circ$  and  $+6^\circ$  result in variations from the  $x$  and  $y$ -values in the range of 0,001 mm to 0,01 mm, which are significantly smaller than the tolerances on  $l_1$ ,  $f$  and  $h_1$ . If necessary, the correction values shall be determined.

Table 6 — Correction values

Dimensions in millimetres

| Style                       | Illustration | $r_{\epsilon}$ | $x$   | $y$   |
|-----------------------------|--------------|----------------|-------|-------|
| <b>A</b><br>and<br><b>G</b> |              | 0,2            | 0,039 | —     |
|                             |              | 0,4            | 0,076 | —     |
|                             |              | 0,8            | 0,152 | —     |
|                             |              | 1,2            | 0,228 | —     |
|                             |              | 1,6            | 0,304 | —     |
|                             |              | 2,4            | 0,456 | —     |
|                             |              | 0,2            | 0,149 | —     |
|                             |              | 0,4            | 0,291 | —     |
|                             |              | 0,8            | 0,581 | —     |
|                             |              | 1,2            | 0,872 | —     |
|                             |              | 1,6            | 1,162 | —     |
|                             |              | 2,4            | 1,743 | —     |
| <b>B</b>                    |              | 0,2            | 0,014 | 0,004 |
|                             |              | 0,4            | 0,028 | 0,007 |
|                             |              | 0,8            | 0,055 | 0,015 |
|                             |              | 1,2            | 0,083 | 0,022 |
|                             |              | 1,6            | 0,110 | 0,029 |
|                             |              | 2,4            | 0,165 | 0,044 |
| <b>B</b><br>and<br><b>R</b> |              | 0,2            | 0,046 | 0,012 |
|                             |              | 0,4            | 0,089 | 0,024 |
|                             |              | 0,8            | 0,178 | 0,048 |
|                             |              | 1,2            | 0,268 | 0,072 |
|                             |              | 1,6            | 0,357 | 0,096 |
|                             |              | 2,4            | 0,535 | 0,147 |

Dimensions in millimetres

| Style    | Illustration | $r_{\epsilon}$ | $x$   | $y$   |
|----------|--------------|----------------|-------|-------|
| <b>D</b> |              | 0,2            | 0,084 | 0,084 |
|          |              | 0,4            | 0,164 | 0,164 |
|          |              | 0,8            | 0,329 | 0,329 |
|          |              | 1,2            | 0,493 | 0,493 |
|          |              | 1,6            | 0,658 | 0,658 |
|          |              | 2,4            | 0,986 | 0,986 |
| <b>F</b> |              | 0,2            | —     | 0,039 |
|          |              | 0,4            | —     | 0,076 |
|          |              | 0,8            | —     | 0,152 |
|          |              | 1,2            | —     | 0,228 |
|          |              | 1,6            | —     | 0,304 |
|          |              | 2,4            | —     | 0,456 |
|          |              | 0,2            | —     | 0,149 |
|          |              | 0,4            | —     | 0,291 |
|          |              | 0,8            | —     | 0,581 |
|          |              | 1,2            | —     | 0,872 |
|          |              | 1,6            | —     | 1,162 |
|          |              | 2,4            | —     | 1,743 |
| <b>H</b> |              | 0,2            | 0,108 | 0,108 |
|          |              | 0,4            | 0,211 | 0,211 |
|          |              | 0,8            | 0,422 | 0,422 |
|          |              | 1,2            | 0,633 | 0,633 |
|          |              | 1,6            | 0,844 | 0,844 |
|          |              | 2,4            | 1,265 | 1,265 |



Table 6 (continued)

| Dimensions in millimetres     |              |              |       |       | Dimensions in millimetres                |              |              |       |       |
|-------------------------------|--------------|--------------|-------|-------|--|--------------|--------------|-------|-------|
| Style                         | Illustration | $r_\epsilon$ | $x$   | $y$   | Style                                    | Illustration | $r_\epsilon$ | $x$   | $y$   |
| H                             |              | 0,2          | 0,342 | 0,180 | K  |              | 0,2          | 0,004 | 0,014 |
|                               |              | 0,4          | 0,684 | 0,360 |  |              | 0,4          | 0,007 | 0,028 |
|                               |              | 0,8          | 1,369 | 0,721 |  |              | 0,8          | 0,015 | 0,055 |
|                               |              | 1,2          | 2,053 | 1,081 |  |              | 1,2          | 0,022 | 0,083 |
|                               |              | 1,6          | 2,738 | 1,441 |  |              | 1,6          | 0,029 | 0,110 |
|                               |              | 2,4          | 4,107 | 2,162 |  |              | 2,4          | 0,044 | 0,165 |
| Indexable insert, rhombic (V) |              | 0,2          | 0,176 | 0,020 | Indexable insert, square                 |              | 0,2          | 0,012 | 0,046 |
|                               |              | 0,4          | 0,344 | 0,039 |  |              | 0,4          | 0,024 | 0,089 |
|                               |              | 0,8          | 0,687 | 0,079 |  |              | 0,8          | 0,048 | 0,178 |
|                               |              | 1,2          | 1,031 | 0,118 |  |              | 1,2          | 0,072 | 0,268 |
|                               |              | 1,6          | 1,375 | 0,157 |  |              | 1,6          | 0,096 | 0,357 |
|                               |              | 2,4          | 2,062 | 0,236 |  |              | 2,4          | 0,143 | 0,535 |
| Indexable insert, rhombic (D) |              | 0,2          | 0,138 | 0,018 | Indexable insert, rhombic (C)            |              | 0,2          | 0,020 | 0,020 |
|                               |              | 0,4          | 0,269 | 0,035 |  |              | 0,4          | 0,040 | 0,040 |
|                               |              | 0,8          | 0,538 | 0,071 |  |              | 0,8          | 0,079 | 0,079 |
|                               |              | 1,2          | 0,806 | 0,106 |  |              | 1,2          | 0,119 | 0,119 |
|                               |              | 1,6          | 1,075 | 0,142 |  |              | 1,6          | 0,159 | 0,159 |
|                               |              | 2,4          | 1,613 | 0,213 |  |              | 2,4          | 0,238 | 0,238 |
| Indexable insert, triangular  |              | 0,2          | 0,420 | 0,033 | Indexable insert, hexagonal, trigone (W) |              | 0,2          | 0,020 | 0,020 |
|                               |              | 0,4          | 0,840 | 0,065 |  |              | 0,4          | 0,040 | 0,040 |
|                               |              | 0,8          | 1,680 | 0,131 |  |              | 0,8          | 0,079 | 0,079 |
|                               |              | 1,2          | 2,519 | 0,196 |  |              | 1,2          | 0,119 | 0,119 |
|                               |              | 1,6          | 3,358 | 0,261 |  |              | 1,6          | 0,159 | 0,159 |
|                               |              | 2,4          | 5,038 | 0,392 |  |              | 2,4          | 0,238 | 0,238 |
| Indexable insert, rhombic (V) |              |              |       |       |  |              |              |       |       |

Table 6 (continued)

Dimensions in millimetres

| Style | Illustration                         | $r_\epsilon$ | $x$   | $y$   |
|-------|--------------------------------------|--------------|-------|-------|
| N     | <p>Indexable insert, rhombic</p>     | 0,2          | 0,237 | 0,121 |
|       |                                      | 0,4          | 0,463 | 0,236 |
|       |                                      | 0,8          | 0,925 | 0,471 |
|       |                                      | 1,2          | 1,388 | 0,707 |
|       |                                      | 1,6          | 1,850 | 0,943 |
|       |                                      | 2,4          | 2,776 | 1,414 |
| N     | <p>Indexable insert, triangular</p>  | 0,2          | 0,203 | 0,103 |
|       |                                      | 0,4          | 0,396 | 0,202 |
|       |                                      | 0,8          | 0,792 | 0,403 |
|       |                                      | 1,2          | 1,187 | 0,605 |
|       |                                      | 1,6          | 1,583 | 0,807 |
|       |                                      | 2,4          | 2,375 | 1,210 |
| S     | <p>Indexable insert, rhombic (C)</p> | 0,2          | 0,112 | 0,112 |
|       |                                      | 0,4          | 0,218 | 0,218 |
|       |                                      | 0,8          | 0,437 | 0,437 |
|       |                                      | 1,2          | 0,655 | 0,655 |
|       |                                      | 1,6          | 0,873 | 0,873 |
|       |                                      | 2,4          | 1,310 | 1,310 |

Dimensions in millimetres

| Style | Illustration                         | $r_\epsilon$ | $x$   | $y$   |
|-------|--------------------------------------|--------------|-------|-------|
| S     | <p>Indexable insert, square (S)</p>  | 0,2          | 0,084 | 0,084 |
|       |                                      | 0,4          | 0,164 | 0,164 |
|       |                                      | 0,8          | 0,329 | 0,329 |
|       |                                      | 1,2          | 0,493 | 0,493 |
|       |                                      | 1,6          | 0,658 | 0,658 |
|       |                                      | 2,4          | 0,986 | 0,986 |
| T     | <p>Indexable insert, triangular</p>  | 0,2          | 0,203 | 0,117 |
|       |                                      | 0,4          | 0,397 | 0,229 |
|       |                                      | 0,8          | 0,794 | 0,458 |
|       |                                      | 1,2          | 1,191 | 0,687 |
|       |                                      | 1,6          | 1,588 | 0,917 |
|       |                                      | 2,4          | 2,381 | 1,375 |
| V     | <p>Indexable insert, rhombic (V)</p> | 0,2          | 0,463 | 0,146 |
|       |                                      | 0,4          | 0,926 | 0,291 |
|       |                                      | 0,8          | 1,851 | 0,582 |
|       |                                      | 1,2          | 2,777 | 0,873 |
|       |                                      | 1,6          | 3,703 | 1,164 |
|       |                                      | 2,4          | 5,539 | 1,747 |

## Annex A (informative)

### Relationship between designations in ISO 5610 (all parts) and ISO/TS 13399-2 and ISO/TS 13399-3

For the relationship between designations in this part of ISO 5610 and preferred symbols according to ISO/TS 13399-2 and ISO/TS 13399-3, see Table A.1.

**Table A.1 — Relationship between designations in ISO 5610 (all parts)  
and ISO/TS 13399-2 and ISO/TS 13399-3**

| Symbol in ISO 5610  | Reference in ISO 5610   | Property name in ISO/TS 13399-2 and ISO/TS 13399-3 | Symbol in ISO/TS 13399-2 and ISO/TS 13399-3 | Reference in ISO/TS 13399-2 and ISO/TS 13399-3 |
|---|---|--|---|--|
| $a^a$   | ISO 5610-1:2010, 5.7 in direction of overall length           | A dimension on lf                                  | LFA   | ISO/TS 13399-3                                 |
| $a^b$   | ISO 5610-1:2010, 5.7 in direction of overall width            | A dimension on wf                                  | WFA   | ISO/TS 13399-3                                 |
| $b$   | ISO 5610-1:2010, Clause 3, Table 1; 4.1, Figure 1 and Table 2 | Shank width  | B   | ISO/TS 13399-3                                 |
| $d$   | ISO 5610-1:2010, 4.1, Figure 1; 5.2, Table 5                  | Inscribed circle diameter                          | IC  | ISO/TS 13399-2                                 |
| $f$   | ISO 5610-1:2010, 4.1, Figure 1; 4.3, Table 4                  | Functional width                                   | WF  | ISO/TS 13399-3                                 |
| $h_1$   | ISO 5610-1:2010, 4.1, Figure 1 and Table 2                    | Functional height                                  | HF  | ISO/TS 13399-3                                 |
| $h_2$   | ISO 5610-1:2010, Clause 3, Table 1; 4.1, Figure 1 and Table 2 | Shank height                                       | H   | ISO/TS 13399-3                                 |
| $l_1$   | ISO 5610-1:2010, 4.1, Figure 1 and Table 2                    | Functional length                                  | LF  | ISO/TS 13399-3                                 |
| $l_2$   | ISO 5610-1:2010, 4.1, Figure 1; 4.2, Table 3                  | Head length  | LH  | ISO/TS 13399-3                                 |
| $l_3$   | ISO 5610-2 to ISO 5610-15                                     | Cutting edge length                                | L   | ISO/TS 13399-2                                 |
| $r_\epsilon$  | ISO 5610-1:2010, 4.1, Figure 1; 5.2, Table 5                  | Corner radius                                      | RE  | ISO/TS 13399-2                                 |
| $\gamma_n$  | ISO 5610-2 to ISO 5610-15                                     | Rake angle normal                                  | GAMN  | ISO/TS 13399-3                                 |
| $\lambda_n$   | ISO 5610-2 to ISO 5610-15                                     | Inclination angle                                  | LAMS  | ISO/TS 13399-3                                 |
| $s$   | ISO 5610-2 to ISO 5610-15                                     | Insert thickness                                   | S   | ISO/TS 13399-2                                 |
| $\kappa_r$  | ISO 5610-2 to ISO 5610-15                                     | Tool cutting edge angle                            | KAPR  | ISO/TS 13399-3                                 |
| <p><sup>a</sup> Dimension <math>a</math> measured in the direction of <math>l_1</math>.</p> <p><sup>b</sup> Dimension <math>a</math> measured in the direction of <math>f</math>.</p> |   |  |   |  |

## Bibliography

- [1] ISO 883, *Indexable hardmetal (carbide) inserts with rounded corners, without fixing hole — Dimensions*
- [2] ISO 3002-1, *Basic quantities in cutting and grinding — Part 1: Geometry of the active part of cutting tools — General terms, reference systems, tool and working angles, chip breakers*
- [3] ISO 3364, *Indexable hardmetal (carbide) inserts with rounded corners, with cylindrical fixing hole — Dimensions*
- [4] ISO 6987, *Indexable hard material inserts with rounded corners, with partly cylindrical fixing hole — Dimensions*
- [5] ISO/TS 13399-2, *Cutting tool data representation and exchange — Part 2: Reference dictionary for the cutting items*
- [6] ISO/TS 13399-3, *Cutting tool data representation and exchange — Part 3: Reference dictionary for tool items*

ISO 9001:2015

---

---

**ICS 25.100.01**

Price based on 16 pages