

INTERNATIONAL  
STANDARD

ISO  
5402-1

IULTCS/IUP 20

Second edition  
2017-02

---

---

**Leather — Determination of flex  
resistance —**

**Part 1:  
Flexometer method**

*Cuir — Détermination de la résistance à la flexion —  
Partie 1: Méthode au flexomètre*



Reference numbers  
ISO 5402-1:2017(E)  
IULTCS/IUP 20:2017(E)

© ISO 2017



**COPYRIGHT PROTECTED DOCUMENT**

© ISO 2017, Published in Switzerland

All rights reserved. Unless otherwise specified, no part of this publication may be reproduced or utilized otherwise in any form or by any means, electronic or mechanical, including photocopying, or posting on the internet or an intranet, without prior written permission. Permission can be requested from either ISO at the address below or ISO's member body in the country of the requester.

ISO copyright office  
Ch. de Blandonnet 8 • CP 401  
CH-1214 Vernier, Geneva, Switzerland  
Tel. +41 22 749 01 11  
Fax +41 22 749 09 47  
copyright@iso.org  
www.iso.org

# Contents

	Page
Foreword .....	iv
<b>1 Scope .....</b>	<b>1</b>
<b>2 Normative references .....</b>	<b>1</b>
<b>3 Terms and definitions .....</b>	<b>1</b>
<b>4 Principle .....</b>	<b>1</b>
<b>5 Apparatus and reagents .....</b>	<b>1</b>
<b>6 Sampling and sample preparation .....</b>	<b>3</b>
<b>7 Procedure .....</b>	<b>3</b>
<b>8 Test report .....</b>	<b>5</b>
<b>Annex A (informative) Sources of apparatus .....</b>	<b>7</b>

## Foreword

ISO (the International Organization for Standardization) is a worldwide federation of national standards bodies (ISO member bodies). The work of preparing International Standards is normally carried out through ISO technical committees. Each member body interested in a subject for which a technical committee has been established has the right to be represented on that committee. International organizations, governmental and non-governmental, in liaison with ISO, also take part in the work. ISO collaborates closely with the International Electrotechnical Commission (IEC) on all matters of electrotechnical standardization.

The procedures used to develop this document and those intended for its further maintenance are described in the ISO/IEC Directives, Part 1. In particular the different approval criteria needed for the different types of ISO documents should be noted. This document was drafted in accordance with the editorial rules of the ISO/IEC Directives, Part 2 (see [www.iso.org/directives](http://www.iso.org/directives)).

Attention is drawn to the possibility that some of the elements of this document may be the subject of patent rights. ISO shall not be held responsible for identifying any or all such patent rights. Details of any patent rights identified during the development of the document will be in the Introduction and/or on the ISO list of patent declarations received (see [www.iso.org/patents](http://www.iso.org/patents)).

Any trade name used in this document is information given for the convenience of users and does not constitute an endorsement.

For an explanation on the meaning of ISO specific terms and expressions related to conformity assessment, as well as information about ISO's adherence to the World Trade Organization (WTO) principles in the Technical Barriers to Trade (TBT) see the following URL: [www.iso.org/iso/foreword.html](http://www.iso.org/iso/foreword.html).

ISO 5402-1 was prepared by the Physical Test Commission of the International Union of Leather Technologists and Chemists Societies (IUP Commission, IULTCS) in collaboration with the European Committee for Standardization (CEN) Technical Committee CEN/TC 289, *Leather*, the secretariat of which is held by UNI, in accordance with the Agreement on technical cooperation between ISO and CEN (Vienna Agreement).

IULTCS, originally formed in 1897, is a world-wide organization of professional leather societies to further the advancement of leather science and technology. IULTCS has three Commissions, which are responsible for establishing international methods for the sampling and testing of leather. ISO recognizes IULTCS as an international standardizing body for the preparation of test methods for leather.

This second edition cancels and replaces the first edition (ISO 5402-1:2011), which has been technically revised.

Subclauses [5.1](#), [5.1.1](#), [5.1.2](#), [7.2](#) to [7.6](#) have been technically revised.

A list of all parts in the ISO 5402 series can be found on the ISO website.

# Leather — Determination of flex resistance —

## Part 1: Flexometer method

### 1 Scope

This document specifies a method for determining the wet or dry flex resistance of leather and finishes applied to leather. It is applicable to all types of flexible leather below 3,0 mm in thickness.

### 2 Normative references

The following documents are referred to in the text in such a way that some or all of their content constitutes requirements of this document. For dated references, only the edition cited applies. For undated references, the latest edition of the referenced document (including any amendments) applies.

ISO 2418, *Leather — Chemical, physical and mechanical and fastness tests — Sampling location*

ISO 2419, *Leather — Physical and mechanical tests — Sample preparation and conditioning*

ISO 3696, *Water for analytical laboratory use — Specification and test methods*

### 3 Terms and definitions

No terms and definitions are listed in this document.

ISO and IEC maintain terminological databases for use in standardization at the following addresses:

- IEC Electropedia: available at <http://www.electropedia.org/>
- ISO Online browsing platform: available at <http://www.iso.org/obp>

### 4 Principle

A test piece is folded with the surface to be tested inwards and clamped in an upper movable clamp and with the surface to be tested outwards in a lower fixed clamp. Movement of the upper clamp causes a fold in the test piece to run along it. The test piece is examined periodically for damage.

### 5 Apparatus and reagents

**5.1 Test machine**, consisting of a movable upper clamp, a fixed lower clamp and a counter as described in [5.1.1](#) to [5.1.3](#) and as shown in [Figure 1](#) and [Figure 2](#).

**5.1.1 Upper clamp**, consisting of a pivoting pair of flat plates of 4 mm thickness as shown in [Figure 1](#).

The small plate (H) has the basic shape of a trapezium but with a radius of 2 mm at the acute corner. It has a ledge (G) to support the folded test piece. The larger plate (I) has a shape as shown in [Figure 1](#). The clamp tightening screw (F) tightens the plates together and also acts as a stop to prevent the test piece from being incorrectly positioned. The design of the clamp should ensure that the two faces of the clamp remain parallel when clamping the test piece. The upper clamp is reciprocated by a motor about a horizontal axle, descending through an angle (A) of  $(22,5 \pm 0,5)^\circ$  at a frequency of  $(100 \pm 5)$  cycles/min.

**5.1.2 Lower clamp**, fixed and lying directly beneath (planar to) the upper clamp and consisting of a pair of flat plates (B and C) to hold the test piece.

The position of the lower clamp is such that the vertical distance (D) between the upper side of the ledge (G) of the upper clamp and the upper edge of the fixed lower clamp, when the upper clamp is horizontal, is  $(25,0 \pm 0,5)$  mm.

**5.1.3 Counter**, to indicate the number of cycles.

Dimensions in millimetres

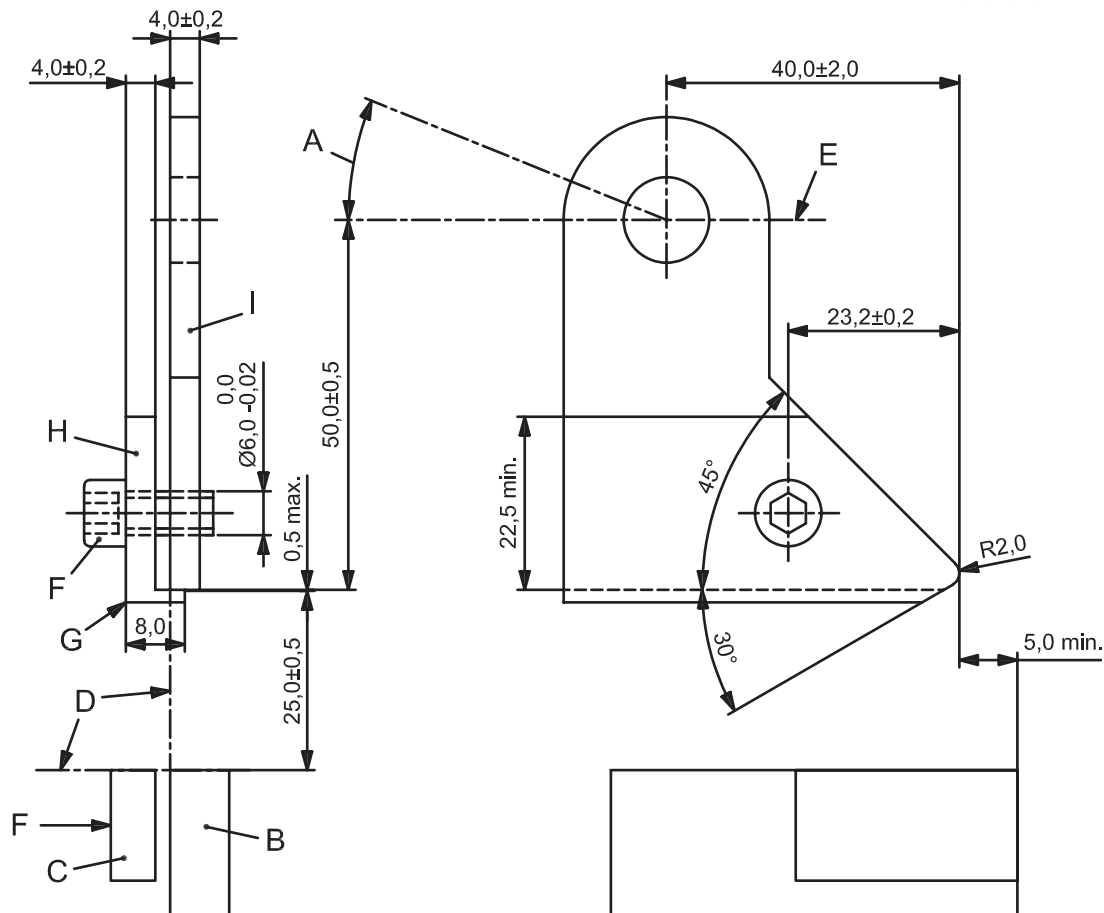

**Key**

- A flexing angle  $(22,5 \pm 0,5)^\circ$
- B fixed part of fixed lower clamp
- C movable part of fixed lower clamp
- D vertical positioning of fixed part of movable upper clamp and fixed part of fixed lower clamp
- E horizontal axle (pivot point)
- F clamp tightening screws
- G ledge (for testing of thick test pieces, the ledge can be increased to more than 8 mm)
- H small part of upper clamp with ledge (G)
- I large part of upper clamp

**Figure 1 — Upper (movable) and lower (fixed) clamp**

**5.2 Press knife**, conforming to the requirements of ISO 2419, the inner wall of which is a rectangle  $(70 \pm 1)$  mm  $\times$   $(45 \pm 1)$  mm.

- 5.3 **Magnifier**, with a magnification of four to six times.
- 5.4 **Desiccator**, or other vessel that can be evacuated.
- 5.5 **Vacuum pump**, capable of reducing the pressure in the desiccator to less than 4 kPa.
- 5.6 **Distilled or deionized water**, conforming to the requirements of grade 3 of ISO 3696.
- 5.7 **Glass dishes**, minimum diameter 100 mm and minimum depth 25 mm.
- 5.8 **Mandrel**, diameter 10 mm and minimum length 70 mm.
- 5.9 **Metal clip**, 70 mm wide, capable to fix a test piece bent around the mandrel (5.8) with slight stretch.
- 5.10 **Stereo microscope**, with a magnification of 25 times.

## 6 Sampling and sample preparation

6.1 Sample in accordance with ISO 2418. From the sample, cut a minimum of four pieces for dry test and/or four pieces for wet test by applying the press knife (5.2) to the surface to be tested. Cut a minimum of two test pieces with the long edge parallel to the backbone and two with the long edge perpendicular to the backbone.

If there is a requirement for more than two hides or skins to be tested in one batch, then only one test piece in each direction need be taken from each hide or skin, provided that the overall total is not less than three pieces in each direction.

6.2 For dry flex testing, condition the test pieces in accordance with ISO 2419 and test in the conditioned atmosphere.

6.3 For wet flex testing, place the test pieces in a glass dish (5.7), add sufficient distilled or deionized water (5.6) to give a minimum depth of 10 mm, put the dish in the desiccator and reduce the pressure to below 4 kPa for 2 min.

Restore to normal atmospheric pressure and repeat the pressure reduction/restoration twice. Remove the test piece and remove excess water using blotting paper. Carry out wet flexing without delay.

NOTE It is not possible to clamp thick leathers in the upper clamp. In such cases, the thickness of the test piece is reduced for a maximum length of 15 mm from one end only and this end inserted in the upper clamp, even so the leather is too stiff to be tested by this method.

## 7 Procedure

7.1 Open the upper and lower clamps (5.1.1 and 5.1.2) so that the gap is at least twice the thickness of the test piece.

7.2 Turn the motor until the lower edge of the upper clamp (5.1.1) is parallel to the upper edge of the fixed lower clamp (5.1.2) as shown in Figure 1 (the point at which the direction of rotation of the horizontal axle changes).

7.3 Fold the test piece in half lengthwise, such that the two long edges are brought together exactly and the grain surface meets face to face. Clamp the folded test piece as shown in Figure 2 a) with the folded edge parallel to, and positioned against, the ledge and with the end of the test piece against the stop

formed by the clamping screw. It has to be ensured that the corners of the test piece within the upper clamp are securely fixed and cannot slip during the test.

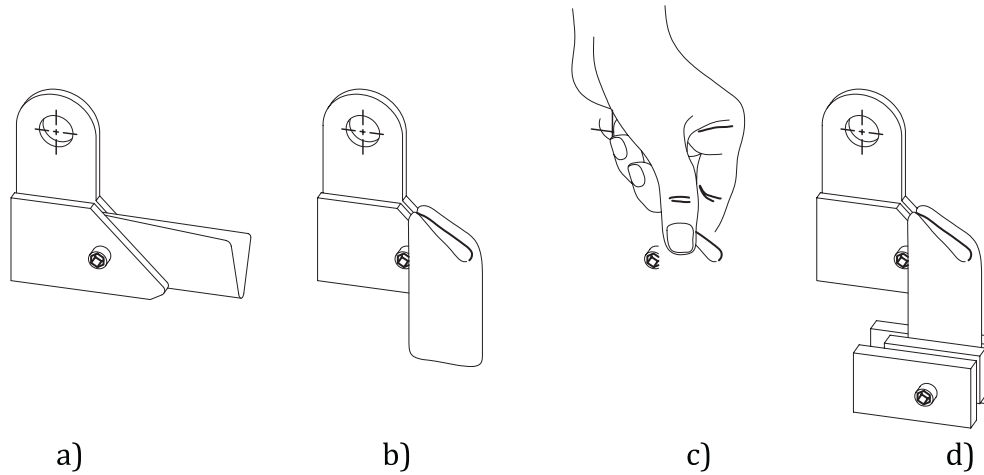

**Key**

- a sample in upper clamp
- b sample folded back
- c sample fixed with two fingers in on upper clamp
- d sample fully clamped

**Figure 2 — Loading of the test piece**

**7.4** Draw the free corners of the test piece outward and downward around the clamp as shown in [Figure 2 b](#)). Bring the inner surfaces together and place the free end in the opened lower clamp.

**7.5** Press the test piece against the outer surfaces of the upper clamp as shown in [Figure 2 c](#)). It is important to ensure that the test piece is in contact with the 45° sloping face of the clamp. This ensures that the lower part of the test piece is perpendicular to the lower clamp. Fix the test piece in this position in the lower clamp [see [Figure 2 d](#))].

**NOTE 1** The procedure ensures that no elongation is applied to the test piece by clamping.

**NOTE 2** Flexible (soft) materials will show a direct contact of their backing on the outer face of the upper clamp. For stiffer materials, ballooning of the materials in this area is unavoidable.

**7.6** Inspect the vertical orientation of the test piece (rear edge). If the rear edge is not perpendicular to the lower clamp, repeat [7.4](#) and [7.5](#).

**7.7** Run the machine for the required number of flex cycles selected from the following list:

- dry flex: 500; 1 000; 5 000; 10 000; 20 000; 25 000; 50 000; 100 000; 150 000; 200 000; 250 000 cycles;
- wet flex: 500; 1 000; 2 500; 10 000; 20 000; 25 000; 50 000 cycles.

In addition to the above inspection points, remove the wet test pieces from the machine every 25 000 cycles and examine them for spue before re-wetting ([6.3](#)) and replacing in the test machine.

**NOTE** Other inspection points are considered if required.

The test pieces should flex without excessive bulging at the sides. If they do not flex in this mode, include this in the test report.



**7.8** Stop the test machine and remove the test piece. Fold it along the longitudinal axis and examine visually in good light using the naked eye and with the magnifier (5.3). Record any damage in the flexed area, ignoring damage in the clamped area.

If required to evaluate the intensity of cracks, bend the test piece along the longitudinal axis around the mandrel (5.8). Stretch the test piece slightly with the fingers or using a clip (5.9). Use the following wording to describe the cracks:

- cracks: visible with naked eye;
- fine cracks: visible with magnifier (5.3);
- micro cracks: visible with microscope, 25 times magnification (5.10).

If required, cut through the flexed area to assist identification of loose leather structure; this will damage the test piece too severely to allow further testing and is only to be carried out after the final inspection.

The damage can include the following:

- a) change of shade (greying) of the finish film without further damage;
- b) cracking or crazing of the finish with the cracking extending through one or more finish layers; the number of cracks may be reported if it is feasible;
- c) loss of adhesion of finish to the leather;
- d) loss of adhesion between finish coats;
- e) powdering or flaking of the finish coats;
- f) colour contrasts shown by finish cracking, powdering or flaking.

**7.9** If required, replace the test piece in the clamps using the marks produced by the clamps as a guide to ensure that the test piece is returned to its original position in the clamps.

**7.10** Restart the machine and continue to the next required number of cycles. Repeat the inspection given in 7.8.

**7.11** Repeat steps 7.9 and 7.10 if required for other numbers of flex cycles.

**NOTE** The actual number of cycles chosen will depend on the specification, the end use of the leather and the expected performance.

**7.12** If only one test piece shows slight damages in final inspection, repeat the test with a new set of minimum of four test pieces. In the case that all of the additional test pieces pass the test without any damage, report as final result “no damages”, otherwise, report the evaluation of the worst test piece.

## 8 Test report

The test report shall include the following:

- a) a reference to this document, i.e. ISO 5402-1:2017;
- b) whether the leather was tested wet or dry;
- c) the number of flex cycles and damage is reported for the worst test piece;
- d) the standard atmosphere used for conditioning and testing as given in ISO 2419;
- e) any deviations from the method specified in this document;

- f) full details for identification of the sample and any deviation from ISO 2418 with respect to sampling.

## **Annex A** (informative)

### **Sources of apparatus**

Examples of sources of suitable apparatus available commercially are given below. This information is given for the convenience of users of this document and does not constitute an endorsement by ISO of these products.

The recommended apparatus is the flexometer manufactured, for example, by

- Giuliani Apparecchi Scientifici via Centrallo 68/18, I-10157 Torino, Italy;
- Muver - Francisco Muñoz Irlles, Avda Hispanoamerica 42, E-03610 Petrer (Alicante), Spain;
- PFI Test and Research Institute, Marie-Curie-Strasse 19, 66953 Pirmasens, Germany;
- SATRA Technology Centre, Wyndham Way, Kettering, Northants, NN16 8SD, England;
- SODEMAT, 29 rue Jean Moulin, ZA Coulmet, F-10450 Breviandes, France.

