

INTERNATIONAL STANDARD

ISO 5367

Fifth edition
2014-10-15

Anaesthetic and respiratory equipment — Breathing sets and connectors

*Matériel d'anesthésie et de réanimation respiratoire — Systèmes
respiratoires et raccords*



Reference number
ISO 5367:2014(E)

© ISO 2014



COPYRIGHT PROTECTED DOCUMENT

© ISO 2014

All rights reserved. Unless otherwise specified, no part of this publication may be reproduced or utilized otherwise in any form or by any means, electronic or mechanical, including photocopying, or posting on the internet or an intranet, without prior written permission. Permission can be requested from either ISO at the address below or ISO's member body in the country of the requester.

ISO copyright office
Case postale 56 • CH-1211 Geneva 20
Tel. + 41 22 749 01 11
Fax + 41 22 749 09 47
E-mail copyright@iso.org
Web www.iso.org

Published in Switzerland

Contents

Page

Foreword	iv
Introduction	v
1 Scope	1
2 Normative references	1
3 Terms and definitions	2
4 General requirements	4
4.1 Risk management.....	4
4.2 Usability.....	4
4.3 Clinical evaluation.....	5
4.4 Biophysical or modelling research.....	5
4.5 Test methods.....	5
4.6 Recommended service life.....	5
5 Specific requirements	5
5.1 Materials.....	5
5.2 Length.....	5
5.3 Means of connection.....	6
5.4 Leakage.....	7
5.5 Resistance to flow.....	7
5.6 Compliance.....	8
6 Prevention of electrostatic charges	9
7 Requirements for breathing sets and breathing tubes supplied sterile	9
7.1 Sterility assurance.....	9
7.2 Packaging of breathing sets and breathing tubes supplied sterile.....	9
8 Marking	10
8.1 General.....	10
8.2 Marking of breathing sets and breathing tubes.....	10
8.3 Marking of packages.....	10
8.4 Information to be supplied by the manufacturer.....	12
Annex A (informative) Rationale	13
Annex B (informative) Hazard identification for risk assessment	23
Annex C (normative) Test for security of attachment of plain end to conical connector	24
Annex D (normative) Test for security of attachment of adaptor to breathing tube	25
Annex E (normative) Test for leakage	26
Annex F (normative) Measurement of resistance to flow	28
Annex G (normative) Test for increase in flow resistance with bending	31
Annex H (normative) Test for compliance	33
Bibliography	35

Foreword

ISO (the International Organization for Standardization) is a worldwide federation of national standards bodies (ISO member bodies). The work of preparing International Standards is normally carried out through ISO technical committees. Each member body interested in a subject for which a technical committee has been established has the right to be represented on that committee. International organizations, governmental and non-governmental, in liaison with ISO, also take part in the work. ISO collaborates closely with the International Electrotechnical Commission (IEC) on all matters of electrotechnical standardization.

The procedures used to develop this document and those intended for its further maintenance are described in the ISO/IEC Directives, Part 1. In particular the different approval criteria needed for the different types of ISO documents should be noted. This document was drafted in accordance with the editorial rules of the ISO/IEC Directives, Part 2 (see www.iso.org/directives).

Attention is drawn to the possibility that some of the elements of this document may be the subject of patent rights. ISO shall not be held responsible for identifying any or all such patent rights. Details of any patent rights identified during the development of the document will be in the Introduction and/or on the ISO list of patent declarations received (see www.iso.org/patents).

Any trade name used in this document is information given for the convenience of users and does not constitute an endorsement.

For an explanation on the meaning of ISO specific terms and expressions related to conformity assessment, as well as information about ISO's adherence to the WTO principles in the Technical Barriers to Trade (TBT) see the following URL: [Foreword - Supplementary information](#)

The committee responsible for this document is ISO/TC 121, *Anaesthetic and respiratory equipment*, Subcommittee SC 2, *Airways and related equipment*.

This fifth edition cancels and replaces the fourth edition (ISO 5367:2000), which has been technically revised.

The following major changes were made:

- title and scope;
- additional normative references;
- additional terms and definitions;
- additional general requirements, including risk management, usability, clinical and biophysical research;
- requirements for coaxial tubing, revised leakage limits, and testing for flow resistance and compliance;
- revised limits for prevention of electrostatic charges;
- revised requirements for marking of packaging, including the use of symbols, disclosure of intended patient category, flow resistance and compliance;
- added an annex for rationale;
- added an annex for hazard identification for risk assessment;
- revised test method annexes for resistance to flow, security of attachments, leakage and compliance;
- added an annex for compliance with the EU Directives.

Introduction

This International Standard contains requirements for **breathing sets**, **breathing tubes**, and connectors that are intended to function as accessories to anaesthetic and respiratory equipment. **Breathing sets** and **breathing tubes** are characterized by certain design requirements such as a means of connection and leakage limits. Disclosure requirements for **compliance** and flow resistance values allow the user to make an informed choice when connecting these accessories to a **breathing system**. These design requirements are intended to allow operation within the limits of performance of the **anaesthetic breathing systems** and **ventilator breathing systems** with which the accessories are intended to operate.

This International Standard includes requirements for both single-use and reusable **breathing sets** and **breathing tubes**. Re-usable **breathing sets and breathing tubes** are intended to comply with the requirements of this International Standard for the recommended service life.

Certain tests are performed under constant pressure to simplify the test methodology. It is recognized that this does not reflect clinical use, where pressure is intermittent and peak pressures occur for short periods. The limits in the test methods take this into account. While such test methods do not address product variability, the limits required also take this into account.

Terms defined in this International Standard are set in **bold type**.

Throughout this International Standard, text for which a rationale is provided in [Annex A](#) is indicated by an asterisk (*).

Throughout this International Standard, all pressures are denoted in SI units of hPa with corresponding cmH₂O equivalent values rounded to the nearest whole cmH₂O.

NOTE The unit cmH₂O is not an SI notation and is not used in ISO documents; rounded cmH₂O values are given for information only to allow comparison to medical literature and related **breathing system** standards.

Anaesthetic and respiratory equipment — Breathing sets and connectors

1 Scope

*This International Standard specifies basic requirements for **breathing sets and breathing tubes** intended to be used with **anaesthetic breathing systems, ventilator breathing systems**, humidifiers or nebulizers. It applies to **breathing sets and breathing tubes** and **patient end adaptors** supplied already assembled and to those supplied as components and assembled in accordance with the manufacturer's instructions.

This International Standard is applicable to **breathing sets** which include special components (e.g. water traps) between the **patient end** and **machine end** which are supplied already assembled.

This International Standard is not applicable to **breathing sets** and **breathing tubes** for special purposes.

EXAMPLE 1 Ventilators having special **compliance**, pressure or breathing frequency requirements.

EXAMPLE 2 High Frequency Oscillatory Ventilation, (HFOV) or High Frequency Jet Ventilation (HFJV).

EXAMPLE 3 **Breathing sets** and **breathing tubes** with special connectors for neonatal ventilation.

Provision is made for coaxial and related bifurcated, double-lumen, or multiple-lumen **breathing sets** and **breathing tubes** suitable for use with **patient end adaptors**.

NOTE 1 Examples of various types of **breathing sets** with **patient end adaptors** are depicted in [Annex A](#).

Requirements for exhalation valves, exhaust valves, **adjustable pressure-limiting (APL) valves**, heat and moisture exchangers (HMEs), breathing filters, and reservoir bags, if provided, are not covered by this International Standard.

NOTE 2 ISO 80601-2-12, ISO 80601-2-13, ISO 9360-1^[3], ISO 23328-2^[4], and ISO 5362^[1] cover these.

NOTE 3 Certain aspects of heated-wire **breathing tubes** are discussed in ISO 8185^[2].

2 Normative references

*The following documents, in whole or in part, are normatively referenced in this document and are indispensable for its application. For dated references, only the edition cited applies. For undated references, the latest edition of the referenced document (including any amendments) applies.

NOTE See [Annex A](#) for information on the use of dated and undated normative references.

ISO 5356-1, *Anaesthetic and respiratory equipment — Conical connectors — Part 1: Cones and sockets*

ISO 7000, *Graphical symbols for use on equipment — Registered symbols*

ISO 10993-1, *Biological evaluation of medical devices — Part 1: Evaluation and testing within a risk management process*

ISO 11607-1, *Packaging for terminally sterilized medical devices — Part 1: Requirements for materials, sterile barrier systems and packaging systems*

ISO 14971, *Medical devices — Application of risk management to medical devices*

ISO 15223-1:2012, *Medical devices — Symbols to be used with medical device labels, labelling and information to be supplied — Part 1: General requirements*

IEC 60417, *Graphical symbols for use on equipment*

IEC 60601-1:2005, *Medical electrical equipment — Part 1: General requirements for basic safety and essential performance*

IEC 60601-1-6, *Medical electrical equipment – Part 1-6: General requirements for basic safety and essential performance – Collateral standard: Usability*

IEC 62366, *Medical devices — Application of usability engineering to medical devices*

ISO 80601-2-12:2011, *Medical electrical equipment — Part 2-12: Particular requirements for basic safety and essential performance of critical care ventilators*

ISO 80601-2-13:2011, *Medical electrical equipment — Part 2-13: Particular requirements for basic safety and essential performance of an anaesthetic workstation*

EN 556-1:2001, *Sterilization of medical devices — Requirements for medical devices to be designated “STERILE” — Part 1: Requirements for terminally sterilized medical devices*

EN 1041, *Information supplied by the manufacturer with medical devices*

3 Terms and definitions

For the purposes of this document, the terms and definitions given in ISO 4135^[5] and ISO 14971 and the following apply.

3.1 adaptor

specialized connector to establish functional continuity between otherwise disparate or incompatible components

[SOURCE: ISO 4135:2001, 4.2.3.1]

3.2 anaesthetic breathing system

inspiratory and expiratory gas pathways through which anaesthetic gas flows at respiratory pressure between the fresh-gas inlet, the **patient connection port** and an exhaust valve or exhaust port

[SOURCE: ISO 80601-2-13:2011, 201.3.203]

3.3 antistatic

property of a material or procedure that disperses or inhibits the accumulation of electrostatic charges

3.4 APL valve adjustable pressure-limiting valve pop-off valve

pressure-limiting valve which releases gas over an adjustable range of pressures

[SOURCE: ISO 4135:2001, 4.3.6, modified]

3.5 assembled end

end of a **breathing tube** incorporating an **adaptor**

3.6**breathing set**

assembly of **breathing tubes**, connectors and components that form the inspiratory and expiratory limbs of the gas pathways of an **anaesthetic** or **ventilator breathing system** between the ventilator and the patient's airway device

Note 1 to entry: The exhaust valve, heat and moisture exchanger (HME), breathing filter, and reservoir bag are not included.

Note 2 to entry: The **patient connection port** is included.

3.7**breathing tube**

non-rigid tube used to convey gases and/or vapours between components of a **breathing system**

[SOURCE: ISO 4135:2001, 4.1.2]

3.8**compliance**

volume added per unit pressure increase when gas is added to an enclosed space, expressed at the temperature and humidity of that enclosed space and at ambient atmospheric pressure

[SOURCE: ISO 4135:2001, 3.1.5]

3.9**machine end**

that end of the **breathing set** or **breathing tube** intended to be connected to the anaesthetic workstation, ventilator or other **breathing system** component furthest from the patient

[SOURCE: ISO 4135:2001, 4.2.3.2, modified]

3.10**patient connection port**

opening at the **patient end** of a **breathing system** intended for connection of an airway device such as a tracheal or tracheostomy tube connector, a face mask, a supralaryngeal airway or a test apparatus

[SOURCE: ISO 4135:2001, 4.2.1.2, modified]

3.11**patient end**

that end of the **breathing set** or **breathing tube** which is intended to be connected to the **patient end adaptor**, **Y-piece** or other appropriate component near the patient

3.12**patient end adaptor**

tubular connector with multiple ports, one of which is a **patient connection port**

Note 1 to entry: Examples of **patient end adaptors** include a **Y-piece**, a **swivel adaptor**, and other specialized **adaptors** for coaxial, multiple tubes, and bifurcated tubes. See also [Annex A](#), [Figures A.1](#) to [A.5](#).

3.13**plain end**

end of a **breathing tube** designed to fit directly over a male conical connector complying with ISO 5356-1

3.14**swivel adaptor**

specialized **adaptor** which allows variation in the position of its ports relative to each other

3.15 ventilator breathing system VBS

inspiratory or expiratory gas pathways through which gas flows at respiratory pressures and bounded by the port through which fresh gas enters, the **patient connection port** and the exhaust port

[SOURCE: ISO 80601-2-12:2011, 201.3.221]

3.16 Y-piece

patient end adaptor as a three-way connector with a **patient connection port** and two ports for connection to **breathing tubes**

[SOURCE: ISO 4135:2001, 4.2.2.2, modified]

4 General requirements

4.1 Risk management

4.1.1 This International Standard specifies requirements that are generally applicable to risks associated with **breathing sets** and **breathing tubes**. An established risk management process shall be applied to the design of the device.

NOTE An informative list of identified hazards is contained in [Annex B](#).

4.1.2 Breathing tubes shall, when transported, stored, installed, operated in normal use and maintained according to the instructions of the manufacturer, present no risks that are not reduced to an acceptable level using risk management procedures in accordance with ISO 14971 and which are connected with their intended application, in normal and in single-fault condition.

NOTE A situation in which a fault is not detected is considered a normal condition. Fault conditions/hazardous situations might remain undetected over a period of time and, as a consequence, might lead to an unacceptable risk. In that case, a subsequently detected fault condition needs to be considered as a single-fault condition. Specific risk control measures need to be determined within the risk management process to deal with such situations.

4.1.3 It is recognized that the manufacturer may not be able to follow all of the processes identified in this International Standard for each constituent component of the **breathing tube**, such as proprietary components, subsystems of non-medical origin, and legacy devices. In this case, the manufacturer should take special account of the need for additional risk control measures.

4.1.4 Where requirements of this International Standard refer to freedom from unacceptable risk, acceptability or unacceptability is determined by the manufacturer in accordance with the manufacturer's policy for determining acceptable risk.

Check compliance by inspection of the risk management file.

4.2 Usability

If required by a competent authority, the manufacturer shall address in a usability engineering process any risks resulting from poor usability (see IEC 60601-1-6 and IEC 62366).

Check compliance by inspection of the usability engineering file.

4.3 Clinical evaluation

If required by a competent authority, a clinical evaluation shall be performed and documented in the technical documentation of the device.

Check compliance by inspection of the technical documentation of the device.

4.4 Biophysical or modelling research

If required by a competent authority, and where appropriate, validated biophysical or modelling research shall be carried out.

Check compliance by inspection of the technical file.

4.5 Test methods

The manufacturer may use type tests different from those detailed within this International Standard, if an equivalent degree of safety is obtained. However, in the event of dispute, the methods specified herein shall be used as the reference methods.

4.6 Recommended service life

Re-usable **breathing sets** and **breathing tubes** shall comply with the requirements of this International Standard throughout the recommended service life as required in [8.4.4](#).

Check compliance by inspection of the manufacturer's technical file.

5 Specific requirements

5.1 Materials

5.1.1 Breathing sets and breathing tubes, in their ready-for-use condition after any preparation recommended by the manufacturer, shall satisfy appropriate biological safety testing, in accordance with ISO 10993-1.

5.1.2 Breathing sets and breathing tubes shall be made of materials suitable for their intended use and, if applicable, shall function in the presence of commonly used concentrations of anaesthetic agents and gases in accordance with their intended use.

5.1.3 If required by a competent authority and if phthalates are incorporated in parts of the medical devices coming directly or indirectly into contact with the patient, the medical device shall be labelled accordingly.

NOTE Attention is drawn to substances which are carcinogenic, mutagenic or toxic to reproduction.

5.1.4 If materials that contain natural rubber (latex) are incorporated in parts of the medical devices coming directly or indirectly into contact with the patient, the medical device shall be labelled accordingly.

5.2 Length

5.2.1 The length of a **breathing tube** shall be designated by its nominal overall length, expressed in metres, when measured in the resting condition (without extension), lying on a horizontal surface. **Breathing tubes** intended to be extended when used shall be designated by both the unextended and extended lengths.

5.2.2 The designated length of a **breathing tube** provided attached to a **Y-piece** or **patient end adaptor** shall include the length of the **Y-piece** or **patient end adaptor** and any **assembled ends**.

5.2.3 The actual length shall be within $\pm 10\%$ of the designated length.

5.3 Means of connection

5.3.1 General

5.3.1.1 Breathing tubes shall have **plain ends** complying with [5.3.2](#) and/or **assembled ends** with **adaptors** incorporating 22 mm or 15 mm conical connectors complying with ISO 5356-1.

5.3.2 Plain ends of breathing tubes

5.3.2.1 The axial length [l_1 in [Figure 1 a\)](#)] of the **plain ends** of **breathing tubes**, excluding those specified in [5.3.2.2](#), shall be not less than 21 mm for **breathing tubes** intended to engage with 22 mm male conical connectors or not less than 14 mm for **breathing tubes** intended to engage with 15 mm male conical connectors.

5.3.2.2 The axial length [l_2 in [Figure 1 a\)](#)] of the **plain ends** of **breathing tubes** that incorporate an internal ridge [see [Figure 1 b\)](#)], intended to engage with the recess at the base of a 22 mm male conical connector as specified in ISO 5356-1, shall be not less than 26,5 mm.

5.3.2.3 When tested as described in [Annex C](#), the **plain ends** of **breathing tubes** shall not become detached from the appropriate male conical connector at a force of less than 40 N.

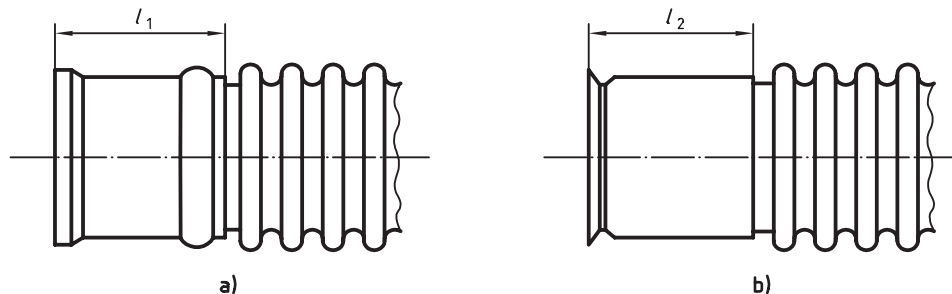

Figure 1 — Axial length of plain end of breathing tube

5.3.3 Adaptor

The end of the **adaptor** that is not intended for attachment to the **breathing tube** shall have a 22 mm or 15 mm **conical connector** complying with ISO 5356-1.

5.3.4 Assembled end

When tested as described in [Annex D](#), the **adaptor** shall not detach from the **breathing tube** at a force of less than 45 N.

NOTE For the purpose of this requirement, a **patient end adaptor** provided securely attached to a **breathing tube** is regarded as an **adaptor**.

5.3.5 Breathing tubes securely attached to a patient end adaptor

For **breathing tubes** supplied securely attached to a **patient end adaptor**, the **patient connection port** of that **patient end adaptor** shall be a 22 mm male/15 mm female coaxial or 15 mm female conical connector complying with ISO 5356-1.

5.3.6 Coaxial or double lumen breathing tubes securely attached to an adaptor

For coaxial or double-lumen **breathing tubes** supplied securely attached to an **adaptor**, the **patient connection port** attached to or part of that **adaptor** shall be a 22 mm male/15 mm female coaxial or 15 mm female conical connector complying with ISO 5356-1.

5.4 Leakage

5.4.1 Leakage from **breathing tubes** supplied to be cut to length shall not exceed 10 ml/min at (60 ± 3) hPa [(60 ± 3) cmH₂O], per metre length of tubing.

Check compliance by testing in accordance with [Annex E](#).

5.4.2 *Leakage from a single **breathing tube** not intended for use with a **VBS** or **anaesthetic breathing system**, shall not exceed 25 ml/min at (60 ± 3) hPa [(60 ± 3) cmH₂O].

Check compliance by testing in accordance with [Annex E](#).

5.4.3 *Leakage from a complete **breathing set** or **breathing tube** supplied ready for use with a **VBS** or **anaesthetic breathing system** shall not exceed the leakage limit listed for the designated patient category in Table 1.

Check compliance by testing in accordance with [Annex E](#).

***Table 1 — Leakage limit by patient category**

Patient category	Intended delivered volume	Leakage limit ml/min	At pressure hPa (cmH ₂ O)
Adult	≥ 300 ml	70	60 ± 3
Paediatric	50 ml < 300 ml	40	60 ± 3
Neonatal	≤ 50 ml	30	60 ± 3
NOTE See Annex E .			

5.5 Resistance to flow

5.5.1 For **breathing tubes** supplied to be cut to length, the manufacturer shall determine and disclose [see [8.4.1 a\)](#)] the resistance to flow per metre length of tubing at the flow listed for the designated patient category in Table 2. The flow resistance shall not exceed the limit in Table 2.

Check compliance by testing in accordance with [Annex F](#).

***Table 2 — Flow resistance limit per metre by patient category for breathing tubes supplied to be cut to length**

Patient category	Intended delivered volume	Flow resistance limit hPa/l/min/m (cmH ₂ O/l/min/m)	At flow l/min
Adult	≥ 300 ml	0,03	30
Paediatric	50 ml < 300 ml	0,06	15
Neonatal	≤ 50 ml	0,37	2,5

NOTE See [Annex E](#).

5.5.2 *For a **breathing tube** supplied ready for use or for each limb of a **breathing set**, the manufacturer shall determine, mark, and disclose [see [8.3 e](#)) and [8.4.1 b](#))] the resistance to flow at the flow listed for the designated patient category Table 3.

If the resistance exceeds the limit listed in Table 3 for the designated patient category, the risk shall be assessed in the risk management file and, if required, marked and disclosed [see [8.3 e](#)) and [8.4.1 b](#))].

Check compliance by testing in accordance with [Annex F](#) and, if required, by inspection of the risk management file.

***Table 3 — Flow resistance limit by patient category for breathing sets and breathing tubes supplied ready for use**

Patient category	Intended delivered volume	Flow resistance limit hPa/l/min (cmH ₂ O/l/min)	At flow l/min
Adult	≥ 300 ml	0,06	30
Paediatric	50 ml < 300 ml	0,12	15
Neonatal	≤ 50 ml	0,74	2,5

NOTE See [Annex E](#).

5.5.3 Regarding the increase in flow resistance with bending, when tested in accordance with [Annex G](#), the pressure at the flow rate stated when the **breathing tube** is suspended over the metal cylinder shall not exceed 150 % of the value obtained when the tube is straight .

5.6 Compliance

5.6.1 For **breathing tubes** supplied to be cut to length, the manufacturer shall determine and disclose [see [8.4.1 d](#))] the **compliance** per metre of tubing at the pressure listed for the designated patient category in [Table 4](#). The compliance per metre of the tubing shall not exceed the limit in [Table 4](#).

Check compliance by testing in accordance with [Annex H](#).

Table 4 — Compliance limit per metre by patient category for breathing tubes supplied to be cut to length

Patient category	Intended delivered volume	Compliance limit ml/hPa/m (ml/cmH ₂ O/m)	At pressure hPa (cmH ₂ O)
Adult	≥ 300 ml	0,8	60 ± 3
Paediatric	50 ml < 300 ml	0,7	60 ± 3
Neonatal	≤ 50 ml	0,3	60 ± 3

NOTE See [Annex H](#).

5.6.2 *For a **breathing set** or **breathing tube** supplied ready for use, the manufacturer shall determine mark, and disclose [See [8.3 g](#)) and [8.4 e](#))] the total **compliance** at the pressure listed for the designated patient category in [Table 5](#).

If the compliance exceeds the limit listed in [Table 5](#) for the designated patient category, the risk shall be assessed in the risk management file and, if required, marked and disclosed [See [8.3 g](#)) and [8.4 e](#))].

Check compliance by testing in accordance with [Annex H](#) and, if required, by inspection of the risk management file.

Table 5 — Compliance limit by patient category for breathing sets and breathing tubes supplied ready for use

Patient category	Intended Delivered Volume ml	Compliance Limit ml/hPa (ml/cmH ₂ O)	At Pressure hPa (cmH ₂ O)
Adult	≥ 300 ml	5	60 ± 3
Paediatric	50 ml < 300 ml	4	60 ± 3
Neonatal	≤ 50 ml	1,5	60 ± 3

NOTE See [Annex H](#).

6 Prevention of electrostatic charges

* **Antistatic breathing tubes** and securely attached components that are for use with flammable anaesthetic mixtures shall have an end-to-end electrical resistance of not less than 1 megaohm (1 MΩ) and not more than 1 000 megaohm (1 000 MΩ) when tested in accordance with the requirements of IEC 60601-1:2005, Annex G.

7 Requirements for breathing sets and breathing tubes supplied sterile

7.1 Sterility assurance

Breathing sets and **breathing tubes** supplied and marked “STERILE” shall satisfy the requirements of subclause 4.1 of EN 556-1:2001.

7.2 Packaging of breathing sets and breathing tubes supplied sterile

7.2.1 Breathing sets and **breathing tubes** supplied and marked “STERILE” shall be contained in an individual pack.

7.2.2 The pack shall serve as an effective barrier to the penetration of microorganisms and particulate matter in accordance with ISO 11607-1.

7.2.3 The pack shall not permit reclosure without clearly revealing that it has been opened.

8 Marking

8.1 General

- a) If required by a local competent authority, **breathing sets** and **breathing tubes**, unit packs, shelf or multi-unit packs, and information to be supplied by the manufacturer shall comply with EN 1041.
- b) The requirements of [8.2](#) and [8.3](#) may be met by use of the appropriate symbols as given in ISO 7000 and ISO 15223-1.

8.2 Marking of breathing sets and breathing tubes

Breathing sets and **breathing tubes** intended for cleaning, reprocessing, and disinfection prior to reuse shall be legibly and durably marked with the following information:

NOTE 1 Marking is required on tubes intended for cleaning, reprocessing and disinfection prior to reuse because this information is often lost after the first use.

- a) the name and/or trademark of the manufacturer and/or supplier;
- b) the batch number and, if required by a local competent authority, for devices placed on the market within the European Community, preceded by the word "LOT";
- c) for **breathing sets** and **breathing tubes** and securely attached non-metallic components made of **antistatic** materials, the word "**ANTISTATIC**";

NOTE 2 They may also bear a continuous indelible yellow-coloured marking throughout their length.

- d) for **breathing sets** and **breathing tubes** that are used with flammable anaesthetic mixtures with air, the characters "AP" (symbol IEC 60417-5331) in a prominent location;
- e) for **breathing sets** and **breathing tubes** that are used with flammable anaesthetic mixtures with oxygen/nitrous oxide, the characters "APG" (symbol IEC 60417-5332) in a prominent location.

8.3 Marking of packages

Packages containing **breathing sets** and **breathing tubes** intended for single use shall be marked with the information given in [8.2](#).

NOTE 1 This information is made available at the point of care.

NOTE 2 Manufacturers' attention is drawn to the regulatory provision requiring that the indication of single use must be consistent across the European Community.

*Packages shall additionally be clearly marked with the following:

- a) the word "STERILE" or the symbol (ISO 7000-2499), if appropriate (the words or the symbol should also indicate the method of sterilization chosen);
- b) the words "single use" or the symbol (ISO 7000-1051), if appropriate;

NOTE 3 Manufacturers' attention is drawn to the regulatory provision requiring that the indication of single use must be consistent across the European Community.

- c) *the designated patient category intended for use of the device, as defined by the intended delivered volume in [Table 6](#);

Table 6 — Patient categories

Patient category	Intended delivered volume ml
Adult	≥ 300 ml
Paediatric	50 ml < 300 ml
Neonatal	≤ 50 ml

- d) the designated length, in accordance with [5.2](#);
- e) for a **breathing tube** supplied ready for use, or for each limb of a **breathing set**, the resistance to flow and the test flow in l/min for the designated patient category in accordance with [5.5.2](#) and, if applicable, the risk assessment disclosure if the flow resistance exceeds the limits listed in Table 3;
- EXAMPLE R_I @ 30 l/min: 0,08 hPa/l/min (cmH₂O/l/min);
 R_E @ 30 l/min: 0,07 hPa/l/min (cmH₂O/l/min)^[8][9].
- f) if other components (e.g. breathing filters, HMEs) are attached to the **breathing set** or **breathing tube**, the total resistance to flow and the test flow in l/min for the designated patient category in accordance with [5.5.2](#) including these attached components;
- g) for a **breathing tube** supplied ready for use or a **breathing set**, the total **compliance** and the test pressure in hPa for the designated patient category in accordance with [5.6.2](#) and, if applicable, the risk assessment disclosure if the compliance exceeds the limits listed in [Table 5](#);
- EXAMPLE C @ 60 hPa: 7 ml/hPa (ml/cmH₂O)^[9].
- h) for **breathing tubes** and **breathing sets**, the minimum inside diameter of the tubing, expressed in millimetres;
- i) the name and/or trademark of the manufacturer and/or supplier and, if required by local competent authority for finished breathing sets and breathing tubes imported into the European Union, in view of their distribution in the Community, the label, or the outer packaging, or instructions for use, shall contain in addition the name and address of the authorized representative where the manufacturer does not have a registered place of business in the Community;
- j) the batch number; and, if required by local competent authority, for devices placed on the market within the European Community, preceded by the word "LOT";
- k) if required by a competent authority, a 'use-by' date shall be given, expressed as the year and month; the symbol may also be used (ISO 7000-2607, ISO 15223-1, 5.12);
- l) for single-use, finished **breathing sets** and **breathing tubes** placed on the market within the European Union, the risks associated with reusing on the labelling or upon request;
- NOTE 4 Manufacturers' attention is drawn to the regulatory provision requiring that the indication of single use must be consistent across the European Community.
- m) if required by a competent authority, a finished breathing set or breathing tube made of materials that incorporate phthalates shall be labelled accordingly; if such breathing set or breathing tube is used for the treatment of children or pregnant or nursing women, the residual risk shall be identified and stated on the label;
- NOTE 5 Attention is drawn to substances which are carcinogenic, mutagenic or toxic to reproduction.
- n) a finished **breathing set** or **breathing tube** made of materials that incorporate natural rubber (latex) shall be labelled accordingly.

8.4 Information to be supplied by the manufacturer

8.4.1 Resistance and compliance information shall be supplied:

- a) for **breathing tubes** supplied to be cut to length, the **resistance** to flow per metre length of tubing and the test flow in l/min for the designated patient category in accordance with [5.5.1](#);
- b) for **breathing tubes** supplied ready for use or for each limb of a **breathing set**, the resistance to flow and the test flow in l/min for the designated patient category in accordance with [5.5.2](#) and, if applicable, the risk assessment disclosure if the flow resistance exceeds the limits listed in Table 3;
- c) if other components (e.g. breathing filters, HMEs) are attached to the **breathing tube** or **breathing set**, the total resistance to flow and the test flow in l/min for the designated patient category, in accordance with [5.5.2](#) including these attached components;
- d) for a **breathing tube** supplied to be cut to length, the **compliance** per metre of tubing and test pressure for the designated patient category in accordance with [5.6.1](#);
- e) for a **breathing tube** supplied ready for use and for **breathing sets**, the total **compliance** and the test pressure in hPa for the designated patient category in accordance with [5.6.2](#) and, if applicable, the risk assessment disclosure if the compliance exceeds the limits listed in [Table 5](#);
- f) if other components (e.g. breathing filters, HMEs) are attached to the **breathing tube** or **breathing set**, the total compliance and test pressure for the designated patient category, in accordance with [5.6.2](#) including these attached components.

8.4.2 The manufacturer shall, when requested, provide information on the recommended maximum working temperature of the **breathing set** or **breathing tube** when attached to a heated humidifier.

8.4.3 The manufacturer shall provide the recommended maximum working pressure of **breathing set** or **breathing tube**.

8.4.4 Unless the **breathing set** or **breathing tube** is intended and marked as being for single use, the manufacturer shall provide details of recommended methods of cleaning and disinfection or sterilization, and the maximum number or period of reuses, if processing in accordance with the provided instructions leads to a degree of degradation that will limit the useful life of the medical device. Where such degradation is established, the manufacturer shall provide an indication of the number of reprocessing cycles that can normally be tolerated, or some other indication of the end of the medical device's ability to safely fulfil its intended use.

NOTE Manufacturers' attention is drawn to the regulatory provision requiring that the indication of single use must be consistent across the European Community.

8.4.5 *For coaxial and double-lumen **breathing sets**, the manufacturer shall provide details of recommended user test methods to verify the integrity of the breathing set before use.

Specialized equipment that is required to perform this user test shall be supplied with the **breathing set** or available from the manufacturer.

NOTE Particular problems with coaxial tubing or double lumen breathing sets with internal components include leakage (to atmosphere and between inspiratory and expiratory tubes), separation, or blockage.

8.4.6 If required by a competent authority, the date of issue or the latest revision of the instructions for use shall be given.

Annex A (informative)

Rationale

This annex provides a concise rationale for the important requirements of this International Standard and is intended for use by those who are familiar with the subject of this International Standard but who have not participated in its development. An understanding of the reasons for the main requirements is considered essential for its proper application. Furthermore, as clinical practices and technologies change, it is believed that rationales for the present requirements will facilitate any revisions of this International Standard necessitated by those developments.

The clauses and subclauses in this annex have been so numbered to correspond to the clauses and subclauses in this International Standard to which they refer. The numbering is, therefore, not consecutive.

Clause 1 Scope

The revised title and broader scope of this edition describe additional requirements for **breathing sets** as finished assemblies of **breathing tubes** and connectors that are intended to function as accessories to **ventilator breathing systems** and **anaesthesia breathing systems**. Also included are **coaxial breathing sets** that contain a smaller diameter **breathing tube** for the inspiratory gas pathway assembled inside a larger diameter **breathing tube** for the expiratory gas pathway and **patient end adaptors** which may differ in construction from the simpler **Y-piece**.

Breathing sets are also commonly known as 'breathing circuits' by clinicians and manufacturers, yet this generic term was found to be confusing in the development of standards by the ISO/TC 121/SC 1 *Breathing attachments and anaesthetic machines* subcommittee and was eventually deprecated.

Breathing sets are not complete 'circuits' as additional devices and accessories are required to perform the task of ventilation, i.e. an anaesthetic machine, ventilator, absorbers, exhaust/expiratory valves etc., all of which are specifically excluded from the scope of this International Standard.

Examples of several different types of **breathing sets** with various types of **patient end adaptors** are depicted in the following figures. Other examples (not shown) may also apply.



Key

- 1 machine end
- 2 patient end

Figure A.1 — Example of a basic anaesthesia breathing set

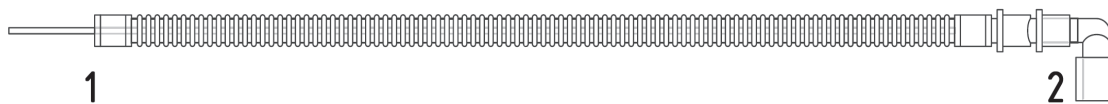

Key

- 1 machine end
- 2 patient end

Figure A.2 — Example of a basic coaxial anaesthesia breathing set

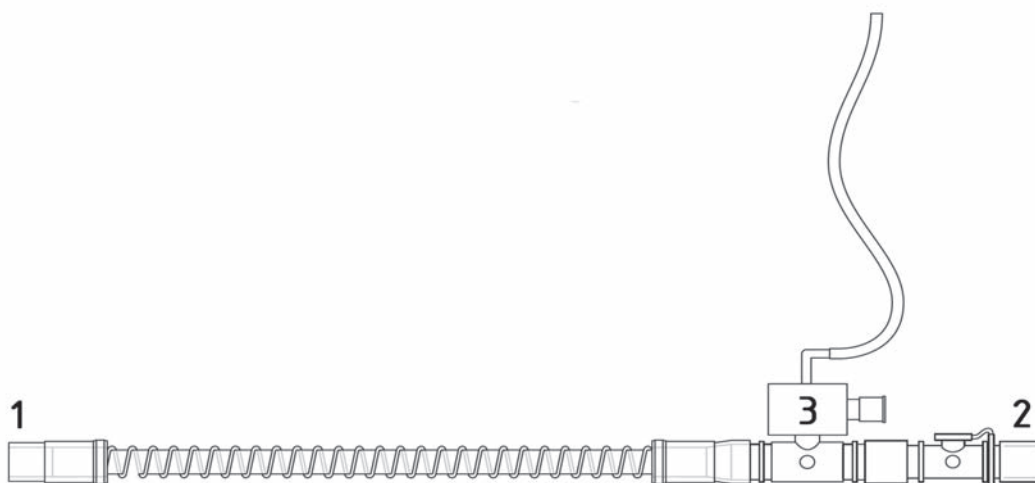

Key

- 1 machine end
- 2 patient end
- 3 exhalation valve (see ISO 80601-2-13)

Figure A.3 — Example of a basic single tube breathing set with exhalation valve

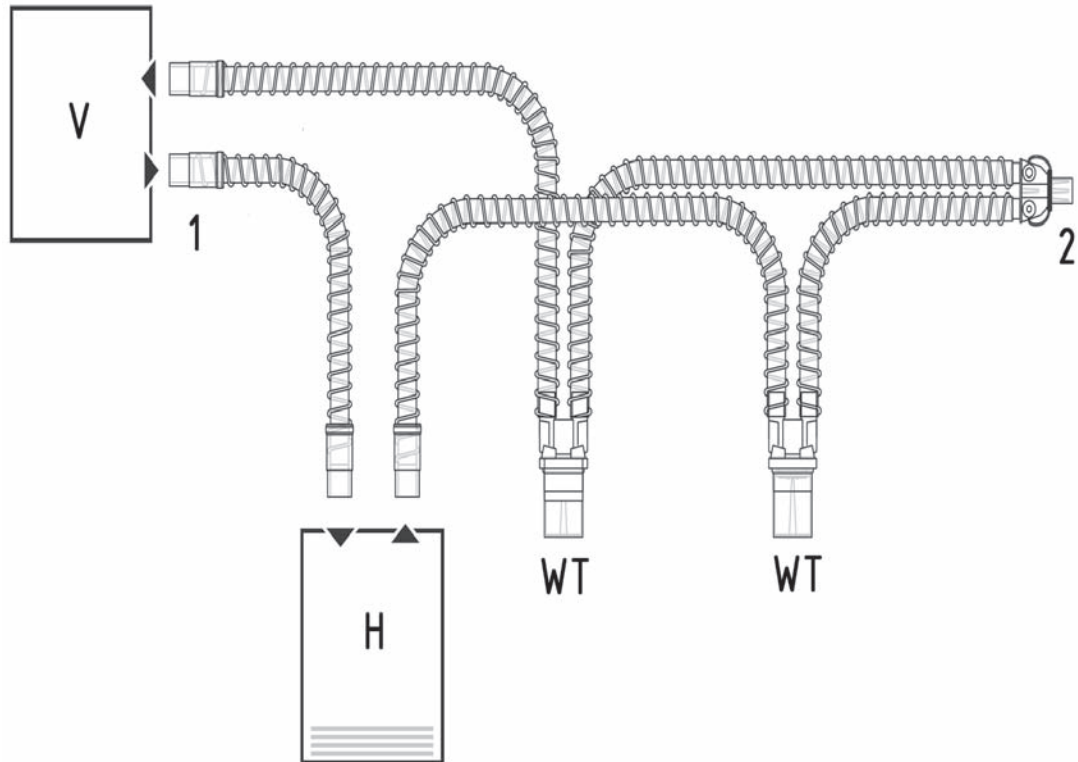

Key

- 1 machine end
- 2 patient end
- V ventilator (see ISO 80601-2-12)
- H humidifier (see ISO 8185)
- WT water trap

Figure A.4 — Example of a critical care ventilator breathing set with water traps and connections to a humidifier and ventilator

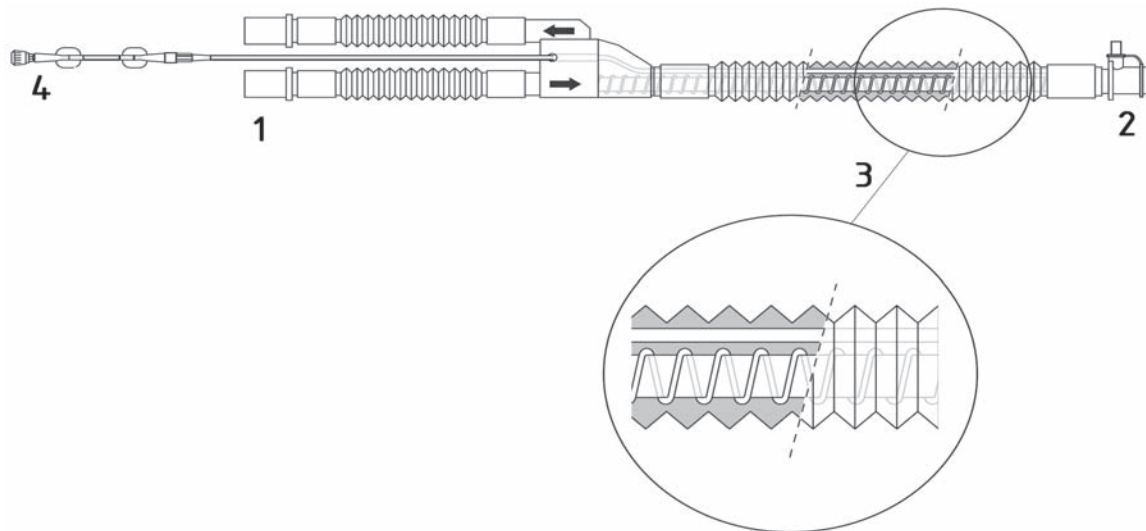

Key

- 1 machine end
- 2 patient end
- 3 multiple lumen coaxial tubing
- 4 gas sampling tubing

Figure A.5 — Example of a multiple-lumen coaxial breathing set with gas sampling tubing

Clause 2 Normative references

Use of dated or undated references have always been a source of confusion. ISO Central Secretariat offered the following information:

Dated references are required when:

- Reference made in text is to a specific edition (or a specific DIS or FDIS) and/or a specific element in the referenced document (obligatory to put the date), e.g. “... in accordance with ISO 6142:—, Clause 5, ...”

NOTE Reference to a term which is recited from the source does not make it a dated normative reference if that norm ref is not cited anywhere else in the document as a requirement.

- Subsequent amendments to, or revisions of, dated references will need to be incorporated by amendment of the document referring to them.

Undated references are permitted when:

- Reference is not to a specific edition nor to any specific element in referenced document (so, reference to a complete document or a part thereof).
- Includes all future changes (Amendments, Technical Corrigenda, new editions) to the referenced document.
- Examples: “... as specified in ISO/IEC Guide 21-1 ...” or “... the terms and definitions given in ISO 10414-2 and ISO 15403, and the following apply ...”

In summary, it is possible to date all the references but the committee will need to watch that the specific edition has not been revised or amended. If this happens, then the document will need to be revised or amended to reflect the new normative reference. The committee will need to be vigilant to make sure that the dated reference is not cancelled and replaced or amended, then the user can no longer comply with the standard. Therefore, the committee needs to watch the normative reference and react if it is

modified. Otherwise if all future revisions would apply, to make sure that the user can always comply with the normative reference.

NOTE The subcommittee considered the European Union's preference for the use of dated references wherever possible, and complied with this preference wherever appropriate.

Subclause 5.4.2 Leakage of single breathing tubes that are not intended for use with a VBS or anaesthetic breathing system

Single **breathing tubes** in this category are typically intended for oxygen therapy, humidification, nebulizer systems, or airway pressure with less critical gas leakage requirements.

Subclause 5.4.3 Leakage of breathing sets and breathing tubes intended for use with a VBS or anaesthetic breathing system

There appears to be no international agreement on the definitions for adult, paediatric, infant, or neonatal body weights, or tidal volumes. Instead, ISO 80601-2-12 and ISO 80601-2-13 agree that patient categories should be replaced with 'relevant delivered volume ranges.'

Table 1 — Leakage limit

The subcommittee worked closely with the developers of the **breathing systems** standards in an effort to determine reasonable leakage limits for **breathing tubes** and **breathing sets**. The subcommittee conservatively decided that **breathing tube** and **breathing set** leakage limits for each patient category in Table 1 should be approximately 30 % of the total system leakage limits for the respective **VBS** and **anaesthetic breathing system** equipment, including accessories, when the **breathing systems** are tested at the same pressures. This value was initially difficult to determine, because the **breathing system** standards differ in the test pressures used to define the leak requirements.

The following models were constructed to help harmonize the various system leak requirements and demonstrate how they fit on leak/pressure curves for each patient category. From these models, appropriate leak rates could be selected system wide. Assuming that the leakage flow can be modelled as if an ideal orifice were producing it, the leak flow model would be:

$$Q_l = G \times \sqrt{P}$$

where

Q_l is the leak flow, in ml/min;

G is the model's orifice conductance coefficient, in ml × (min × hPa)⁻¹;

P is the test pressure, in hPa (cmH₂O).

Using the leakage limits established in ISO 80601-2-12, the model's orifice conductance G can be found for each of the ranges.

For example, the leakage limit for an Adult VBS is 200 ml/min when tested at 50 hPa (50 cmH₂O). Thus:

$$200 = G \times \sqrt{50}$$

$$G = 28,28 \text{ ml} \times (\text{min} \times \text{hPa})^{-1}.$$

In the same manner the conductance coefficients for the leak models of Paediatric and Neonatal VBS are calculated:

Adult: $G = 28,28 \text{ ml} \times (\text{min} \times \text{hPa})^{-1}$

Paediatric: $G = 16,77 \text{ ml} \times (\text{min} \times \text{hPa})^{-1}$

Neonatal: $G = 11,18 \text{ ml} \times (\text{min} \times \text{hPa})^{-1}$

With these coefficients, it is then possible to find the VBS leakage limit at any pressure desired, as depicted in [Figure A.6](#).

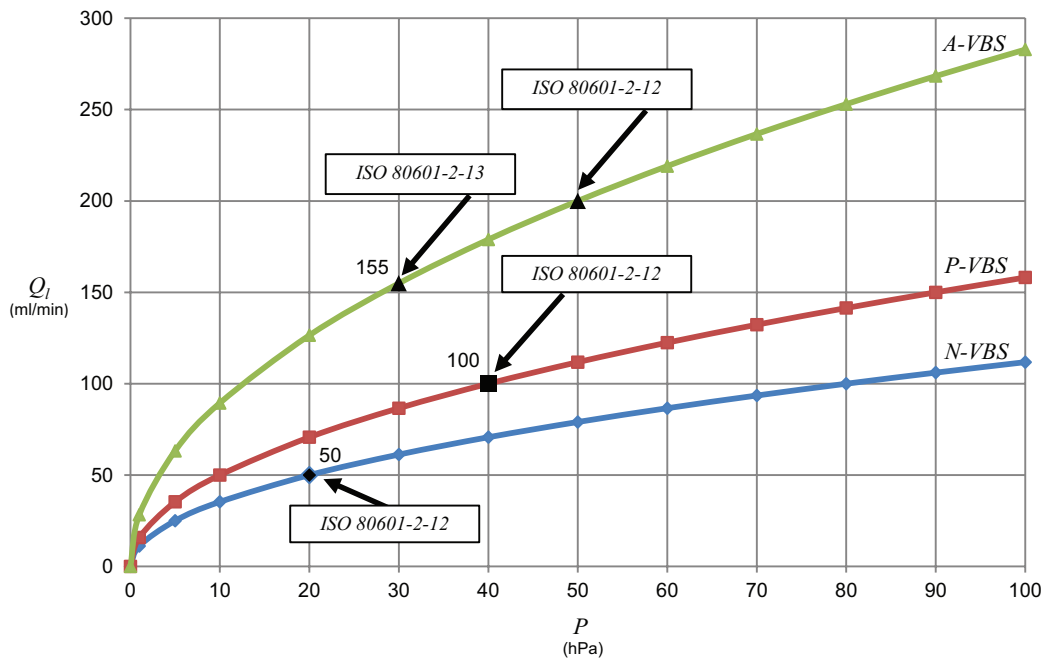

Key

- P pressure (hPa)
- Q_l leak limit (ml/min)
- A-VBS leak limit versus pressure curve for an Adult Ventilator Breathing System (VBS)
- P-VBS leak limit versus pressure curve for a Paediatric Ventilator Breathing System (VBS)
- N-VBS leak limit versus pressure curve for a Neonatal Ventilator Breathing System (VBS)
- ISO 80601-2-12 leak limit value as expressed in the ISO 80601-2-12 standard
- ISO 80601-2-13 leak limit value as expressed in the ISO 80601-2-13 standard

NOTE 1 Breathing systems leakage limits as specified in ISO 80601-2-12 and ISO 80601-2-13 are compared.

NOTE 2 The leak model is assumed to behave as an orifice. That is $Q_l = G \times \sqrt{P}$ where G is the model's orifice conductance coefficient.

Figure A.6 — VBS leakage limits by breathing system standard

If the leakage flow limit models are then evaluated at 60 hPa (60 cmH₂O), as depicted in [Figure A.7](#), the leak limit requirements expressed in the various ISO breathing systems standards are harmonized by expressing them at one common pressure.

The leak limit values for a **breathing set** or **breathing tube** for use with a **VBS** that appear in Table 1 were then derived as 30 % of values in [Figure A.7](#) at 60 hPa (60 cmH₂O) and rounded up, as agreed by the subcommittee.

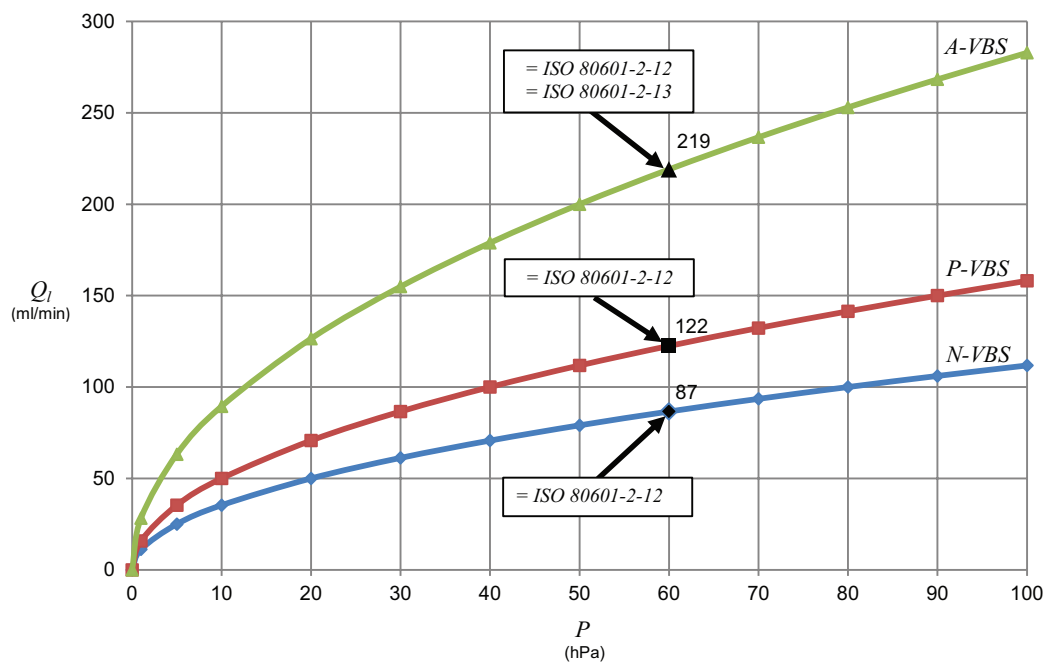

Key

- P* pressure (hPa)
- Q_l* leak limit (ml/min)
- A-VBS* leak limit versus pressure curve for an Adult Ventilator Breathing System (VBS)
- P-VBS* leak limit versus pressure curve for a Paediatric Ventilator Breathing System (VBS)
- N-VBS* leak limit versus pressure curve for a Neonatal Ventilator Breathing System (VBS)
- = ISO 80601-2-12 equivalent to the leak limit value as expressed in the ISO 80601-2-12 standard
- = ISO 80601-2-13 equivalent to the leak limit value as expressed in the ISO 80601-2-13 standard

NOTE 1 Breathing system leakage limits that are equivalent to those specified in ISO 80601-2-12 and ISO 80601-2-13 are compared.

NOTE 2 The leak model is assumed to behave as an orifice. That is $Q_l = G \times \sqrt{P}$ where *G* is the model's orifice conductance coefficient.

Figure A.7 — VBS leakage limits evaluated at the new pressure level

Tables 2 and 3 — Flow resistance

A similar approach was taken with the developers of the **breathing systems** standards to harmonize the flow resistance test methods between the **breathing sets**, **breathing tubes**, and the various **VBSs** and **anaesthetic breathing systems**. The subcommittee conservatively decided that **breathing tube** and **breathing set** resistance limit for each patient category in Table 3 should be approximately 30 % of the total system resistance limit for the respective **breathing systems** when all are tested at the same flow. For **breathing tubes** supplied to be cut to length, the 30 % value for each limb of a typical **breathing set** was then expressed on a per metre basis for each patient category in Table 2. The **breathing system** resistance value was initially difficult to determine, because the **breathing system** standards differ in the test flows used to define the resistance requirements.

Assuming that the resistance limit can be modelled as a linear function of flow, the resistance model would be:

$$R = S \times Q$$

where

R is resistance, in hPa/l/min/m (cmH₂O/l/min/m);

Q is flow, in l/min;

S is the proportionality constant coefficient, in hPa/(l/min)².

Note that the fact that R is a linear function of Q through the constant S implies that the resistance, as pressure drop across the length of the tubing, can be found as:

$$\Delta P = R \times Q = (S \times Q) \times Q = S \times Q^2$$

where

ΔP is pressure drop across the length of the tubing, in hPa (cmH₂O).

Thus using the leakage limits established in the ISO 80601-2-12 and the equation for determining the resistance (R) across the **VBS**, the linear coefficient (S) can be found for each of the ranges.

For example, the S factor for the Adult **VBS** with a pressure drop (ΔP) limit of 6 hPa at a flow (Q) of 30 l/min is:

$$\Delta P = 6 \text{ hPa at } 30 \text{ l/min}$$

$$6 \text{ hPa} = S \times 30 \text{ l/min} \times 30 \text{ l/min}$$

$$S = 0,0067 \text{ hPa/(l/min)}^2$$

$$R = 0,0067 \text{ hPa/(l/min)}^2 \times 30 \text{ l/min}$$

$$R = 0,2 \text{ hPa/l/min}$$

Then proceeding in the same way the S factor and the resulting maximum **VBS** resistance limits for the paediatric and neonatal **VBS** are calculated:

Adult: $R = 0,2 \text{ hPa/l/min at } 30 \text{ l/min}$

Paediatric: $R = 0,4 \text{ hPa/l/min at } 15 \text{ l/min}$

Neonatal: $R = 2,4 \text{ hPa/l/min at } 2,5 \text{ l/min}$

The limits in Table 3 are then derived as 30 % of the **breathing system limits** at the flow for each patient category. The Table 3 limits apply to the **breathing tube** or for each limb of a **breathing set** only and do not include pressure drops induced by other components of the **VBS** that are not components of the **breathing tube** or **breathing set** (e.g. heated humidifier, APL). This is why a 30 % factor has been proposed. This factor represents the percentage (expressed in decimal format) of the total **VBS** maximum resistance limit that is applicable to the **breathing set** or **breathing tube** components alone.

Subclause 5.5.2 Resistance to flow

Flow resistance of the total **breathing system** should not exceed that of the ventilator or anaesthesia workstation of 6 hPa (6 cmH₂O) at the flow rate required to deliver the intended volume (ISO 80601-2-12, ISO 80601-2-13, or other relevant standard that describes total system flow resistance for the intended use of the **breathing set** or **breathing tube**).

The increase in pressure associated with the supplied **breathing set** alone should be limited to the lowest possible value and, ideally, not exceed 1,8 hPa (1,8 cmH₂O) at the flow rate required to deliver the intended volume, because other components added by the user may add flow resistance that will exceed the system limits.

The committee agreed that flow resistance should include that added by turbulent flow within the components. Expiratory flow resistance is the most critical value to control. Special characteristics of coaxial tubes may require separate disclosure of both inspiratory and expiratory flow resistance. This is important when the machine fails and when the patient is forced to inhale and exhale spontaneously through the components and valves. Normal upper airway flow resistance is approximately 3 hPa (3 cmH₂O) at the flow rate required to deliver the intended volume. Heat and moisture exchangers (HMEs), filters, and other components add significant flow resistance. Therefore **breathing sets** should not increase this flow resistance, if possible.

The committee also agreed to add requirements to disclose flow resistance values for **breathing sets** and **breathing tubes** intended for neonatal and paediatric patient categories. While there was no agreement on the definitions for adult, paediatric, infant, or neonatal categories defined by body weight or tidal volume, the committee agreed to harmonize the patient categories with those described in ISO 80601-2-12 and ISO 80601-2-13 as 'relevant delivered volume ranges'. It was understood that the patient categories should be further classified, if necessary, to those relating to 'invasive' and 'non-invasive' ventilation requirements, because the performance of many non-invasive ventilation applications of **breathing sets** are less critical.

Subclause 5.6.2 Compliance

The committee agreed that testing and marking the total compliance of the breathing set and **breathing tube** is clinically useful because the value may be additive to the compliance values for the other accessories and help provide the user with a clearer understanding the total compliance of the **VBS** or **anaesthetic breathing system**.

Compliance limits will vary greatly with patient category. Neonatal and paediatric **breathing sets** must have lower **compliance** values in order to function within the ventilator's **compliance** tolerance limits. Errors in the estimation of the total **breathing system compliance** will greatly affect the accuracy of delivered gas volumes.

Clause 6 Prevention of electrostatic charges

Antistatic tubing should be sufficiently conductive to allow any charge to dissipate, but not so conductive as to allow a potentially harmful current to flow.

There is a need to distinguish between levels of conductivity. A tube could be:

- conductive – able to conduct significant amounts of current;
- antistatic – able to dissipate charge over time to prevent static buildup;
- insulating – does not conduct – static charge will not dissipate.

ISO 60601-1, 8.7.3 c) defines a limit of touch current of a maximum of 500 μ A in single-fault condition with direct current. Using this value as a limit, and assuming the highest voltage likely to be present at the machine end of a **breathing tube** is a mains voltage of 250 V, Ohms law of $V/I = R$ gives a value of R at 500 000 Ω .

So to limit the current to less than 500 μ A if a maximum of mains voltage is applied to one end of an antistatic tube, the end-to-end resistance of the tube should be more than 500 000 Ω .

Doubling this for safety leads to a minimum value of 1 M Ω , end-to-end.

The upper limit of 1 000 M Ω is suggested to ensure that sufficient conductivity is present to still allow static charges to dissipate, before they can build up and potentially cause a spark.

Subclause 8.3 Marking of packages

The marking requirement for 'rated flow' was removed from this edition as it was believed to be poorly understood and did not comply with the requirements for the equipment with which the **breathing sets** and **breathing tubes** are intended to be used.

Subclause 8.3 c) Patient category, Table 6

The definition for patient category is harmonized with ISO 80601-2-12.

Subclause 8.4.5 Coaxial breathing set user test methods

User testing of coaxial breathing sets for the integrity of the internal circuit prior to use on a patient may be required because the security of the inner tubing may not be visible to the user. Manufacturers need to instruct the operator on how to ascertain the integrity of the internal lumen to reduce the risk of a faulty connection leading to rebreathing of carbon dioxide and other problems.

The following tests have been described for use with a coaxial Mapleson D circuit (e.g. Bain circuit) [6], however, these tests are not applicable for use with circle systems and may be unreliable with Bain circuits [7]:

- observation of a decrement in flow when the distal orifice of the internal circuit was occluded, and
- observation of an accelerated deflation of the reservoir bag by a venturi effect with a high flow through the inner tube.

Annex B (informative)

Hazard identification for risk assessment

NOTE [Annex B](#) is not an exhaustive or inclusive list of all known hazards and serves only as a guide for developers and users of **breathing sets** and **breathing tubes**.

- a) Emission of harmful gases: attention is drawn to the absorption of inhalational anaesthetic agents and other substances by **breathing tubes**. These agents and substances may be subsequently liberated and may pose a hazard.
- b) Delamination, leading to increased flow resistance: for **breathing tubes** of a laminated construction, there is a risk of internal de-lamination and bubble formation when they are exposed to inhalational anaesthetic agents.
- c) Kinking.
- d) Disconnection.
- e) Obstruction.
- f) Detachment of connector.
- g) Hole in the inner tube of a coaxial tube or septum of a double-lumen tube.
- h) High flow resistance.
- i) Alteration of anaesthetic gases by dissolving substances from the hose material to the breathing gas [e.g. plasticizers, like phthalates, di(2-ethylhexyl) phthalate (DEHP)].
- j) Insufficient ventilation of the patient by using tubing with excessive compliance.
- k) Insufficient ventilation of the patient due to inability to correct for excessive VBS compliance, resulting from damaged, leaky or corrupted breathing tubes.
- l) Allergy, including allergy to natural rubber latex.

Annex C (normative)

Test for security of attachment of plain end to conical connector

C.1 Principle

The security of attachment of a plain-ended **breathing tube** to a male conical connector that is intended to be detachable by an operator is tested by applying a tensile load along the linear axis of the end and noting whether the end becomes detached from the connector at a specified force.

C.2 Test piece

The test is carried out on a **breathing tube** with a **plain end**.

C.3 Apparatus

C.3.1 Means of applying a tensile load of not less than 40 N, at a rate of (50 ± 5) mm/min along the linear axis of the tube at least 150 mm from the end of the tube.

C.3.2 Means of measuring the applied tensile load, with an accuracy of ± 2 N.

C.3.3 A 22 mm or 15 mm male conical test connector, as appropriate for the size of **breathing tube** to be tested, made of metal with a recess in the case of a 22 mm connector, dimensioned as specified in ISO 5356-1 and having a surface roughness of $0,8 \mu\text{m}$ (roughness number N6).

C.4 Procedure

C.4.1 Condition the **breathing tube**, or **breathing tube** with connector at $(42 \pm 3)^\circ\text{C}$ and at not less than 80 % relative humidity for at least 1 h prior to testing. Conduct the test procedure at a temperature of $(23 \pm 3)^\circ\text{C}$ within 5 min after the 1 h conditioning.

NOTE Conditioning at a high temperature is intended to replicate the temperature of the tubing and gas pathways after 1) exposure to the exothermic reactions within carbon dioxide absorbers, 2) the high temperatures of heated humidifiers or 3) the high ambient temperatures when placed in proximity to warming blankets.

C.4.2 Engage the end of the **breathing tube** over the test connector by wetting the end in distilled water and fitting it over the test connector so that the entire axial length of the connector is covered. Secure the conical test connector.

C.4.3 Apply a tensile load of not less than 40 N at a rate of (50 ± 5) mm/min at a point not less than 150 mm from the end of the tube, along the linear axis of the tube, and visually inspect the integrity of the connection of the tube to the male conical test connector.

C.5 Expression of results

Note whether the tube becomes detached from the male conical test connector at a force less than 40 N.

Annex D (normative)

Test for security of attachment of adaptor to breathing tube

D.1 Principle

The security of attachment of an **adaptor** to a **breathing tube** is tested by applying a tensile load along the linear axis of the **assembled end** and noting whether the **adaptor** becomes detached from the body of the **breathing tube** at a specified force.

D.2 Test piece

The test is carried out on a **breathing tube** with an **assembled end**.

D.3 Apparatus

D.3.1 Means of securing the **adaptor** of the **assembled end** of the **breathing tube**, so that the **adaptor** is not distorted and withstands a tensile load of > 45 N applied for 1 min along the linear axis of the tube at least 150 mm from the end of the tube.

D.3.2 Means of measuring the applied tensile load, with an accuracy of ± 2 N.

D.3.3 Means of applying a tensile load of not less than 45 N at a rate of (50 ± 5) mm/min along the linear axis of the **assembled end** of the tube.

D.4 Procedure

D.4.1 Condition the **breathing tube**, or **breathing tube** with connector at $(42 \pm 3)^\circ\text{C}$ and at not less than 80 % relative humidity for at least 1 h prior to testing. Conduct the test procedure at a temperature of $(23 \pm 3)^\circ\text{C}$ within 5 min after the 1 h conditioning.

NOTE Conditioning with high temperature is intended to replicate the temperature of the tubing and gas pathways after 1) exposure to the exothermic reactions within carbon dioxide absorbers, or 2) the high temperatures of heated humidifiers, or 3) the high ambient temperatures when placed in proximity to warming blankets.

D.4.2 Secure the **adaptor** so that the part incorporated into the **breathing tube** is not distorted.

D.4.3 Apply a tensile load at a rate of (50 ± 5) mm/min at a point not less than 150 mm from the end of the **breathing tube** along the linear axis of the tube, and visually inspect the integrity of the connection of the **breathing tube** to the **adaptor**.

D.5 Expression of results

Note whether the tube becomes detached from the **adaptor** at a force less than 45 N.

Annex E (normative)

Test for leakage

E.1 Principle

Leakage is tested by applying and maintaining an internal gas pressure by introducing air into a **breathing tube** or **breathing set**, and recording the flow of air required to maintain that internal pressure. This will test leakage from the body of the **breathing tube**; in the case of a **breathing tube** or **breathing set** with **assembled ends**, from the tube, the **adaptor** and their connection; and in the case of **breathing tubes** with **plain ends**, from the connection of the **breathing tube** to an appropriately-sized male **conical connector**.

E.2 Test piece

The test is carried out on a **breathing tube** or **breathing set** as supplied in its ready for use condition. **Breathing tubes** supplied uncut are cut to a length suitable for testing.

E.3 Apparatus

E.3.1 Means of applying and maintaining an internal gas pressure of (60 ± 3) hPa [(60 ± 3) cmH₂O].

E.3.2 Means of conditioning the **breathing tube** and carrying out the test procedure at a temperature of (23 ± 3) °C.

E.3.3 Means of recording air flow rate to 100 ml/min, accurate to within 5 % at 50 hPa (50 cmH₂O).

E.3.4 An appropriately sized male conical test connector, as in [C.3.3](#).

E.4 Procedure

E.4.1 Test conditions

Condition the test piece at a temperature of (23 ± 3) °C for at least 1 h prior to testing. Maintain this temperature during testing.

E.4.2 Engaging the test piece to the test apparatus

NOTE Care should be taken when performing the test to exclude the possibility of leaking between the tubing and the apparatus.

E.4.2.1 For a **breathing tube** supplied to be cut to length, cut a suitable length of not less than 1 m as the test piece.

E.4.2.2 For a **breathing tube** intended to be extended when used, condition and test in the extended state.

E.4.2.3 For a single **breathing tube**, or length of **breathing tube** supplied to be cut to length, engage the end over the test connector as in [C.4.2](#), closing off one end.

E.4.2.4 For complete **breathing sets** or **breathing tubes** supplied in pairs with **assembled ends** and **Y-piece** or **patient end adaptor**, and all provided components, engage the end of one opening of the **breathing tube** over the test connector as in [C.4.2](#), occluding the other two openings and **APL valve** or exhaust valve or exhalation valve, if fitted.

E.4.3 Application of internal gas pressure

Apply an internal gas pressure of (60 ± 3) hPa [(60 ± 3) cmH₂O] by introducing air into the **breathing tube** or **breathing set** and allowing the pressure to stabilize. Record the flow rate of air required to maintain that internal gas pressure.

E.5 Expression of results

E.5.1 Express the flow rate of air required to maintain the specified internal gas pressure in millilitres per minute.

E.5.2 For **breathing tubes** supplied to be cut to length, express the result in millilitres per minute per metre length of tubing.

Annex F (normative)

Measurement of resistance to flow

F.1 Principle

The resistance to flow is tested by measuring the pressure increase through the **breathing set**, **breathing tube**, or **breathing tube** with connector.

F.2 Test piece

F.2.1 The test is carried out on a **breathing set**, **breathing tube** supplied ready for use, or a 1 m length of **breathing tube** supplied to be cut to length.

F.2.2 If other components (e.g. breathing filters, HMEs) are attached to the **breathing set** or **breathing tube**, an additional test is carried out including these attached components. [See [8.4.1 c](#)].

F.3 Apparatus

F.3.1 Flow-controlling device, capable of controlling the flow of air and having an accuracy of $\pm 2,5\%$.

F.3.2 Pressure-measuring device, having an accuracy of $\pm 0,10$ hPa ($\pm 0,10$ cmH₂O).

F.3.3 Buffer reservoir, comprising a sealed jar of 5 l capacity with a gas inlet placed near the bottom of the jar and a gas outlet placed at the top of the jar (see [Figure F.1](#)). The outlet shall be funnel-shaped with an inside diameter greater than that of the **breathing tube** under test. A connection to the pressure-measuring device ([F.3.2](#)) shall be placed in the jar halfway between the gas inlet and gas outlet. Any transition in inside diameter between the outlet and the connector, if provided, and the **breathing tube** should be smooth to minimize turbulent flow.

F.3.4 Compressed non-condensing air.

F.4 Procedure

F.4.1 Condition the test piece at a temperature of (23 ± 3) °C for at least 1 h prior to testing. Maintain this temperature during testing.

F.4.2 Set up the apparatus as shown in [Figure F.1](#), but without the **breathing tube** attached. Adjust the air flow rate to the flow stated in [Table F.1](#) and maintain for 30 s. Record the reading (p_1) on the pressure-measuring device.

F.4.3 Fit the **breathing set** or **breathing tube**, including integral connectors if present, over the outlet of the buffer reservoir using an appropriate connector.

F.4.4 For **breathing tubes** intended to be extended when used, condition and test in the extended state.

F.4.5 For **breathing sets** and **breathing tubes** supplied in pairs securely attached to a **patient end adaptor**, occlude one opening of the tube at its **machine end**. Secure the free end of the tube being tested, so that it is held straight and not constricted.

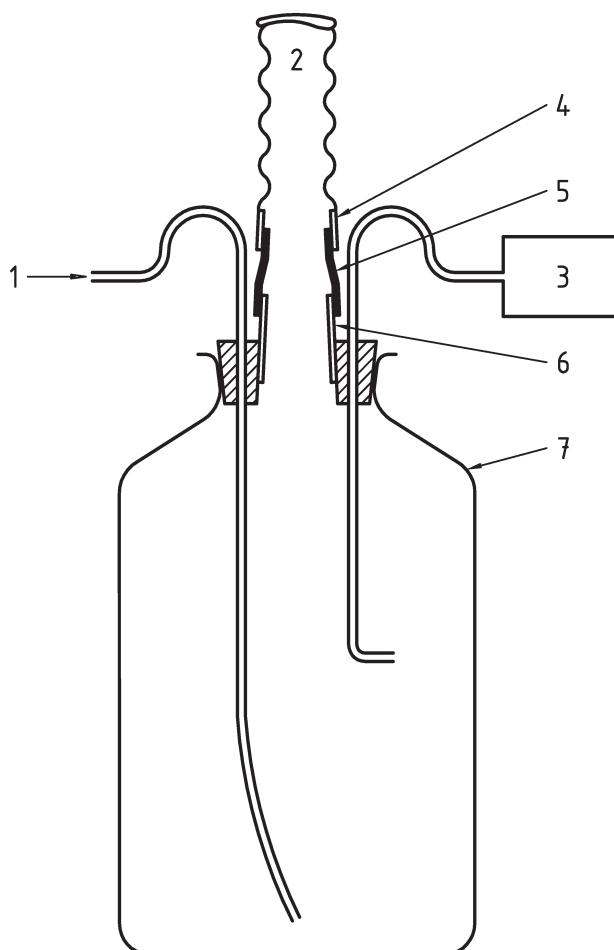

Key

- 1 air from flow-controlling device
- 2 breathing tube
- 3 pressure-measuring device
- 4 adaptor with conical connector, if provided
- 5 conical connector
- 6 outlet
- 7 buffer reservoir

Figure F.1 — Typical apparatus for measuring resistance to air flow

F.4.6 Test the **breathing tube** according to its intended use.

Table F.1 — Test Flow Rates

Patient category	Intended delivered volume ml	Test flow l/min
Adult	≥ 300 ml	30
Paediatric	50 ml < 300 ml	15
Neonatal	≤ 50 ml	2,5

F.4.7 Adjust the air flow to that stated in [Table F.1](#) and maintain it for 30 s. Record the reading (p_2) on the pressure-measuring device.

F.4.8 Calculate the increase in pressure due to the **breathing tube** ($p_2 - p_1$), expressed in hPa and cmH₂O.

F.4.9 For **breathing tubes** supplied in pairs securely attached to a **patient end adaptor**, repeat the procedure given in [F.4.6](#) to [F.4.8](#) using the other **breathing tube** with the previously tested **breathing tube** occluded at its **machine end**.

F.5 Expression of results

F.5.1 For **breathing tubes** supplied ready for use, express the increase in pressure ($p_2 - p_1$) in hPa and cmH₂O for the inspiratory and expiratory **breathing tubes**, if applicable.

F.5.2 For **breathing tubes** supplied to be cut to length, express the increase in pressure ($p_2 - p_1$) in hPa and cmH₂O per metre length of tubing.

Annex G (normative)

Test for increase in flow resistance with bending

G.1 Principle

The resistance to air flow when the tube is straight is determined as in [Annex F](#). The increase in flow resistance of a tube with bending is tested by suspending the tube over a metal cylinder of small diameter and maintaining the **breathing tube** in contact with half the circumference of the cylinder for the duration of the testing. Suspended masses or alternative tensile forces applied to the ends of the tube can ensure that contact is maintained. The air is introduced into the tube at the flow rate that corresponds to the patient category and the increase in pressure is recorded.

G.2 Test piece

The test is carried out on a **breathing tube**.

G.3 Apparatus

G.3.1 Metal cylinder, having a diameter of 2,5 cm (simulating a bed rail).

G.3.2 Pair of weights, of a mass just sufficient to maintain the **breathing tube** in continuous contact with half the circumference of the metal cylinder.

G.3.3 Flow-measuring device, pressure-measuring device and buffer reservoir, as specified in [F.3](#).

G.3.4 Means of controlling air at the test flow for the patient category stated in [Table G.1](#), to an accuracy of $\pm 2,5$ %.

G.3.5 Means of heating and controlling the temperature of the **breathing tube** to $(42 \pm 3)^\circ\text{C}$ and not less than 80 % humidity.

Table G.1 — Test flow for flow resistance to bending

Patient category	Intended delivered volume ml	Test flow l/min
Adult	≥ 300 ml	30
Paediatric	50 ml < 300 ml	15
Neonatal	≤ 50 ml	2,5

G.4 Procedure

G.4.1 Carry out the test procedure described in [Annex F](#), Resistance to flow, and record the pressure as p_1 .

G.4.2 Condition the **breathing set** or **breathing tube** tested in [G.4.2](#) at $(42 \pm 3)^\circ\text{C}$ and at not less than 80 % relative humidity for at least 1 h. Conduct the test procedure at a temperature of $(23 \pm 3)^\circ\text{C}$ within 5 min after conditioning.

NOTE Conditioning at a high temperature is intended to replicate the temperature of the tubing and gas pathways after 1) exposure to the exothermic reactions within carbon dioxide absorbers, or 2) the high temperatures of heated humidifiers, or 3) the high ambient temperatures when placed in proximity to warming blankets.

G.4.3 **Breathing tubes** intended to be extended when used shall be tested in the extended state.

G.4.4 Immediately after conditioning, suspend the **breathing set** or **breathing tube** over the metal cylinder and attach weights or alternative materials from each end of the tube, of a mass just sufficient to maintain the tube in continuous contact over half of the circumference of the metal cylinder.

G.4.5 Within 5 min of conditioning the **breathing tube**, introduce the air flow into the tube at the end at which the pressure-measuring device is connected. Record the pressure (p_2) at 5 min.

G.4.6 For multiple-lumen **breathing tubes** and **breathing tubes** with a septum, perform multiple tests by suspending the tube with each lumen and each septum over the metal cylinder.

G.5 Expression of results

Express p_2 as a percentage of p_1 .

Annex H (normative)

Test for compliance

H.1 Principle

The **compliance** of the **breathing set**, **breathing tube**, or **breathing tube** with connectors is determined, after sealing off any leaks as previously determined in [Annex E](#), by inflating the tube to achieve a specified pressure and recording the volume of air required.

H.2 Test piece

H.2.1 For **breathing tubes** supplied uncut, the test is carried out on a cut section of **breathing tube** with a known length.

H.2.2 For multiple-lumen **breathing tubes**, **breathing tubes** supplied preassembled to connectors and ports and **breathing sets**, the test is carried out on the entire assembly after connecting all provided **breathing tubes**, connectors and ports.

H.2.3 If other components (e.g. breathing filters, HMEs) are attached to the **breathing set** or **breathing tube**, an additional test is carried out including these attached components. [See [8.4.1 f](#)].

H.3 Apparatus

H.3.1 Means of inflating the tube with air, to a gauge pressure of (60 ± 3) hPa [(60 ± 3) cmH₂O].

H.3.2 Means of recording the volume of air required.

H.3.3 Pressure-measuring device, as specified in [F.3.2](#).

H.3.4 Means of ensuring free movement along the length of tube, (e.g. a water bath on which to float the tube).

H.4 Procedure

H.4.1 Determine the presence of any leakage of the test piece in accordance with [Annex E](#). Seal all leaks and retest until leakage is < 1 ml/min.

H.4.2 Condition the **breathing set**, or **breathing tube** tested in [G.4](#) at (42 ± 3) °C and at not less than 80 % relative humidity for at least 1 h. Conduct the test procedure at a temperature of (23 ± 3) °C within 5 min after conditioning.

NOTE Conditioning at a high temperature is intended to replicate the temperature of the tubing and gas pathways after 1) exposure to the exothermic reactions within carbon dioxide absorbers, 2) the high temperatures of heated humidifiers or 3) the high ambient temperatures when placed in proximity to warming blankets.

H.4.3 **Breathing tubes** intended to be extended when used shall be tested in the extended state.

H.4.4 Measure, at ambient pressure, the overall length of the test piece as in 5.2, excluding the length of any connectors, **patient end adaptors** or **Y-piece**.

H.4.5 Block one end of the **breathing tube** and mount the tube in such a manner so as not to impede movement, for example by floating it on water. If the **breathing tube** is supplied with an integral **patient end adaptor** or **Y-piece**, block the **patient connection port**.

H.4.6 Connect the pressure-measuring device to the open end of the tube.

H.4.7 Inflate the test piece over a period of time not exceeding 5 s with sufficient air to achieve a stable gauge pressure of (60 ± 3) hPa [(60 ± 3) cmH₂O], and record the volume of air required.

H.5 Expression of results

H.5.1 For uncut **breathing tubes**, express the **compliance** of the gas pathway in ml/hPa (ml/cmH₂O) per metre length of tube.

H.5.2 For **breathing sets** and **breathing tubes** pre-assembled to ports and connectors, express the **compliance** of all gas pathways of the entire assembly of tubes, ports, and connectors as ml/hPa (ml/cmH₂O).

Bibliography

- [1] ISO 5362:2006, *Anaesthetic reservoir bags*
- [2] ISO 8185:2007, *Respiratory tract humidifiers for medical use — Particular requirements for respiratory humidification systems*
- [3] ISO 9360-1:2000, *Anaesthetic and respiratory equipment — Heat and moisture exchangers (HMEs) for humidifying respired gases in humans — Part 1: HMEs for use with minimum tidal volumes of 250 ml*
- [4] ISO 23328-2:2002, *Breathing system filters for anaesthetic and respiratory use — Part 2: Non-filtration aspects*
- [5] ISO 4135:2001, *Anaesthetic and respiratory equipment — Vocabulary*
- [6] DORSCH J.A., & DORSCH S.E. *Understanding Anesthesia Equipment*, 5th edition, Wolters Kluwer/Lippincott Williams and Wilkins, 2008
- [7] SZYPULA K.A., IP J.K., BOGOD D., YENTIS S.M. Detection of inner tube defects in co-axial circle and Bain breathing systems: a comparison of occlusion and Pethick tests. *Anaesthesia*. 2008, **63** pp. 1092–1095
- [8] Pulmonary terms and symbols. A report of the ACCP-STS Joint Committee on Pulmonary Nomenclature *Chest*. 1975;67(5):583-593
- [9] RESPIRATORY CARE STANDARD ABBREVIATIONS AND SYMBOLS. *Respir. Care*. 1997 June, **42** () pp. 637–642

ICS 11.040.10

Price based on 35 pages

© ISO 2014 – All rights reserved