

INTERNATIONAL STANDARD

ISO 5355

Fourth edition
2005-07-01

Corrected version
2006-03-15

Alpine ski-boots — Requirements and test methods

Chaussures de ski pour skis alpins — Exigences et méthodes d'essai



Reference number
ISO 5355:2006(E)

© ISO 2006

PDF disclaimer

This PDF file may contain embedded typefaces. In accordance with Adobe's licensing policy, this file may be printed or viewed but shall not be edited unless the typefaces which are embedded are licensed to and installed on the computer performing the editing. In downloading this file, parties accept therein the responsibility of not infringing Adobe's licensing policy. The ISO Central Secretariat accepts no liability in this area.

Adobe is a trademark of Adobe Systems Incorporated.

Details of the software products used to create this PDF file can be found in the General Info relative to the file; the PDF-creation parameters were optimized for printing. Every care has been taken to ensure that the file is suitable for use by ISO member bodies. In the unlikely event that a problem relating to it is found, please inform the Central Secretariat at the address given below.

© ISO 2006

All rights reserved. Unless otherwise specified, no part of this publication may be reproduced or utilized in any form or by any means, electronic or mechanical, including photocopying and microfilm, without permission in writing from either ISO at the address below or ISO's member body in the country of the requester.

ISO copyright office
Case postale 56 • CH-1211 Geneva 20
Tel. + 41 22 749 01 11
Fax + 41 22 749 09 47
E-mail copyright@iso.org
Web www.iso.org

Published in Switzerland

Contents

Page

Foreword.....	iv
1 Scope	1
2 Normative references	1
3 Terms and definitions.....	1
4 Requirements and test methods	2
5 Marking	25
Annex A (normative) Mondopoint system ski-boot sizing and marking	26
Annex B (informative) Dimensions and requirements of “2nd degree”	28

Foreword

ISO (the International Organization for Standardization) is a worldwide federation of national standards bodies (ISO member bodies). The work of preparing International Standards is normally carried out through ISO technical committees. Each member body interested in a subject for which a technical committee has been established has the right to be represented on that committee. International organizations, governmental and non-governmental, in liaison with ISO, also take part in the work. ISO collaborates closely with the International Electrotechnical Commission (IEC) on all matters of electrotechnical standardization.

International Standards are drafted in accordance with the rules given in the ISO/IEC Directives, Part 2.

The main task of technical committees is to prepare International Standards. Draft International Standards adopted by the technical committees are circulated to the member bodies for voting. Publication as an International Standard requires approval by at least 75 % of the member bodies casting a vote.

Attention is drawn to the possibility that some of the elements of this document may be the subject of patent rights. ISO shall not be held responsible for identifying any or all such patent rights.

ISO 5355 was prepared by Technical Committee ISO/TC 83, *Sports and recreational equipment*, Subcommittee SC 3, *Ski bindings*.

This fourth edition cancels and replaces the third edition (ISO 5355:1997), which has been restructured and technically revised.

In this corrected version of ISO 5355:2005 the following subclauses have undergone a change in presentation in order to improve clarity: 4.2.2.3, 4.3.4, 4.3.5.1.1, 4.3.5.1.2, 4.3.5.1.3, 4.3.5.2.1, 4.3.5.2.2, 4.3.8.1.2, 4.3.8.2.2.2, 4.3.8.4.2.2, 4.3.10 and 4.3.11.

Subclause 4.3.6.1.1 has additional data incorporated. There are also corrections in: line 1 of 4.3.6.3; 4.3.9.2.2 b) 1); 4.3.9.2.2 d); Clauses B.1 and B.2.

Alpine ski-boots — Requirements and test methods

1 Scope

This International Standard specifies the requirements, test methods and marking of ski-boots which are used with current systems of alpine ski-bindings with attachment at the boot toe and boot heel, the proper release function of which depends on the dimensions and design of the interfaces.

For ski-binding systems that function irrespective of the sole shape or that have different requirements for the sole dimensions, it is not always necessary for the ski-boot soles to comply with this International Standard in order to achieve the desired degree of safety.

It applies to ski-boots of sizes 15,0 and larger (types A and C) in the Mondopoint system (see Annex A).

2 Normative references

The following referenced documents are indispensable for the application of this document. For dated references, only the edition cited applies. For undated references, the latest edition of the referenced document (including any amendments) applies.

ISO 527-1, *Plastics — Determination of tensile properties — Part 1: General principles*

ISO 554, *Standard atmospheres for conditioning and/or testing — Specifications*

ISO 868, *Plastics and ebonite — Determination of indentation hardness by means of a durometer (Shore hardness)*

ISO 1183:1987, *Plastics — Methods for determining the density and relative density of non-cellular plastics*

ISO 2039-1:2001, *Plastics — Determination of hardness — Part 1: Ball indentation method*

ISO 9407, *Shoe sizes — Mondopoint system of sizing and marking*

3 Terms and definitions

For the purposes of this document, the following terms and definitions apply.

3.1

interface

that part of the ski-boot intended for contact with the ski-binding

3.2

front interface

that part of the ski-boot intended to fit with the front binding

3.3

rear interface

that part of the ski-boot intended to fit with the rear binding

3.4

free space

space intended to avoid contact between ski-boot and binding, especially during step in/step out or release

3.5

median plane

middle plane of the sole, longitudinal and perpendicular to the bearing surface

3.6

bearing surfaces

front and rear surfaces of the boot sole which are in contact with a plane on which the boot is standing

3.7

ski-brake

device to stop the ski after release of the binding

4 Requirements and test methods

4.1 General

If no specific test methods are indicated, check the characteristics as appropriate, e.g. by measurement.

If not otherwise indicated, execute the testing under standard atmosphere 23/50 (see ISO 554) with ordinary tolerances.

4.2 Dimensions

4.2.1 Requirements

The boot toe and heel shall comply with Figures 1 and 2. Other boot dimensions need not correspond to the figures.

Fundamentally, all dimensions shall be within the indicated tolerances. However, relevance to safety varies in importance depending on the indicated dimensions.

Looking at several dimensions ("dimensions of the 2nd degree") a deviation from the tolerances can be accepted, provided that the following requirements are respected.

- a) The deviations shall remain exceptional.
- b) The deviations are small.
- c) No limitations of function arise with all marketable and critical bindings.
- d) The tolerances are respected at the next possible opportunity (e.g. reconstruction of a tool).

See Annex B.

Dimensions in millimetres

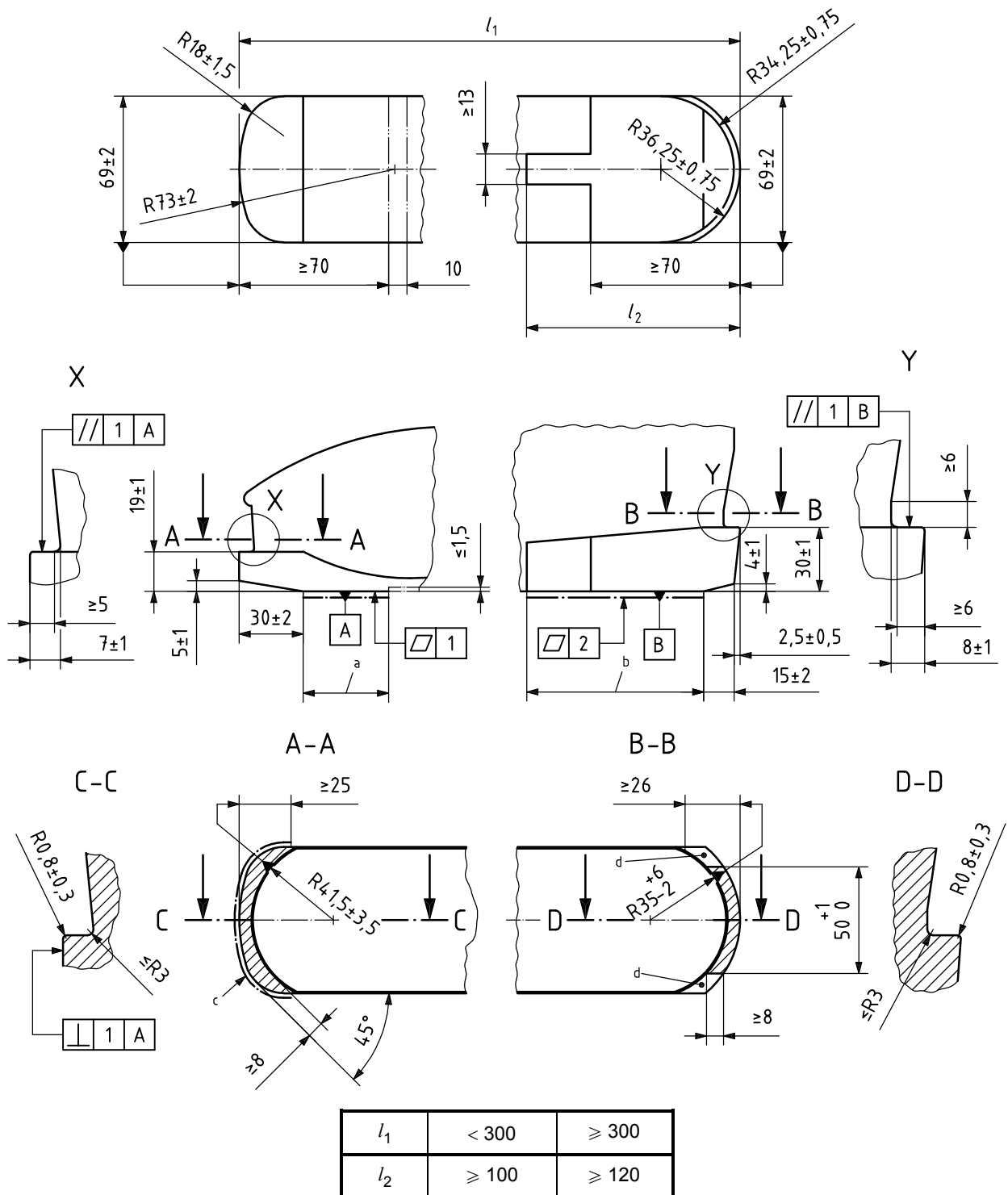

NOTE Shaded areas including areas with index ^d are those in which the tolerances of evenness and the dimensions (19 ± 1) mm and (30 ± 1) mm are valid.

- a Low-friction zone/bearing surface.
- b Bearing surface (see 3.6).
- c Area in which the tolerance of perpendicularity is valid (see 4.3.3).
- d Reserved areas for adjustment device.

Figure 1 — Dimensions of boot toe and heel, type A

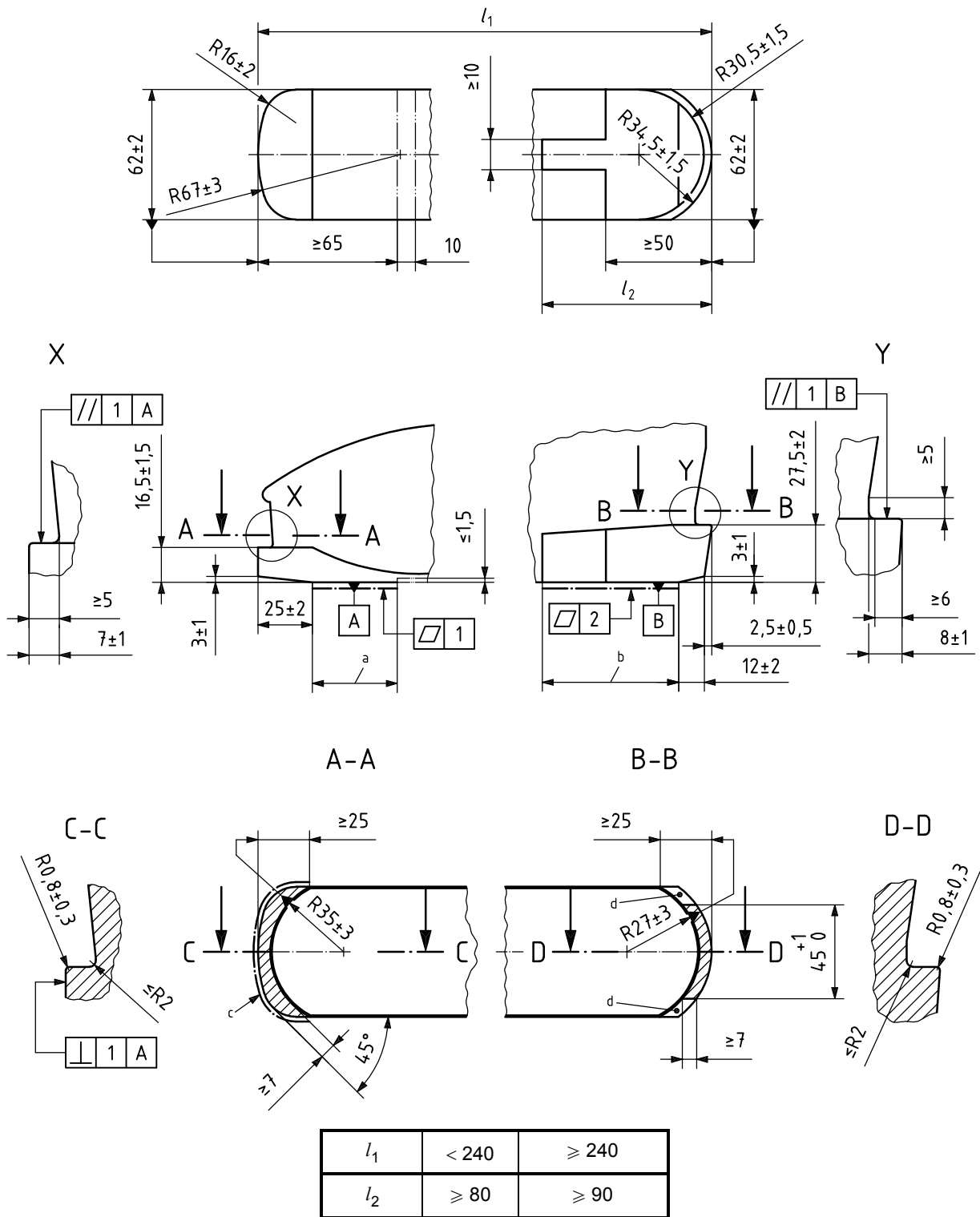

NOTE Shaded areas including areas with index ^d are those in which the tolerances of evenness and the dimensions (16,5 ± 1,5) mm and (27,5 ± 2) mm are valid.

- a Low-friction zone/bearing surface.
- b Bearing surface (see 3.6).
- c Area in which the tolerance of perpendicularity is valid (see 4.3.3).
- d Reserved areas for adjustment device.

Figure 2 — Dimensions of boot toe and heel, type C

4.2.2 Testing of evenness

4.2.2.1 When the front bearing surface rests on a plane, a gauge 1 mm thick and 10 mm wide shall not enter the AB area at any point. See Figure 3.

4.2.2.2 When the rear bearing surface rests on a plane, a gauge 1 mm thick and 10 mm wide shall not enter the CD area at any point. See Figure 4.

4.2.2.3 Before measuring the evenness of the bearing surfaces as described in Figure 5, apply a load of

type A: 100 N;

type C: 50 N

by inserting into the ski-boot itself a steel cylinder with a diameter of

type A: 80 mm;

type C: 50 mm

the ends rounded with a 10 mm radius and having a corresponding mass. After 5 min, determine the flatness measurement as follows.

When the boot rests on the test plane (see Figure 5), check the maximum thickness of a 10 mm wide gauge which can enter the BC area anywhere (to a maximum of 2 mm). This gauge shall not enter the AB and CD areas.

Dimensions in millimetres

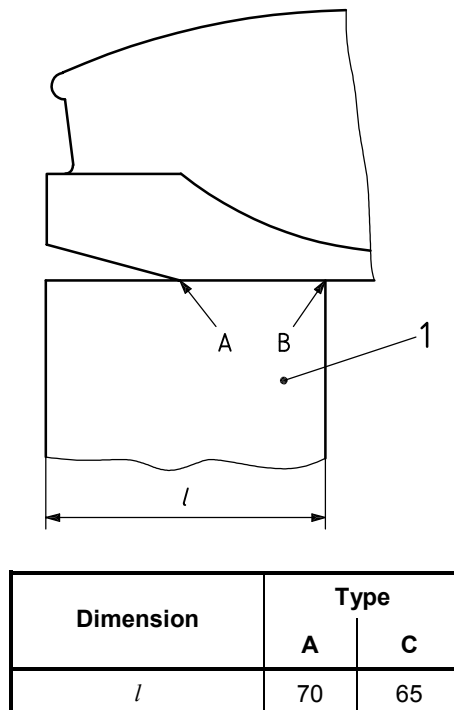

Key

1 test plane

Figure 3 — Testing of evenness at the front

Dimensions in millimetres

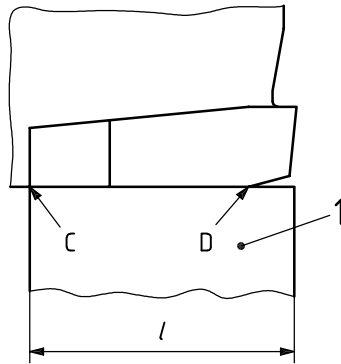

Dimension	Type	
	A	C
l	100	80

Key
1 test plane

Figure 4 — Testing of evenness at the rear

Dimensions in millimetres

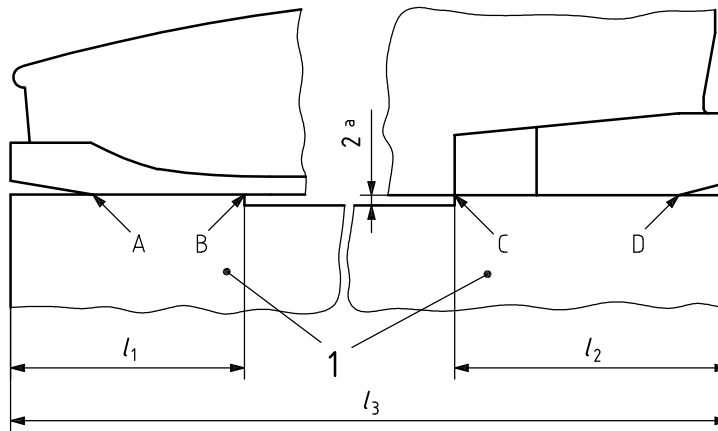

Dimension	Type	
	A	C
l_1	70	65
l_2	100	80
l_3	Sole length	

Key
1 test plane
a Cut-out in the test surface.

Figure 5 — Testing of evenness of the whole boot

4.3 Design

4.3.1 Sole length

The sole lengths of the two ski-boots in a pair shall not differ by more than 2 mm.

4.3.2 Symmetry

The sole dimensions in the toe and heel interface areas shall be symmetrical about the median plane within an admissible deviation of 1 mm.

4.3.3 Side walls at boot toe

The side walls of the sole at the boot toe, up to a distance of at least 25 mm from the toe end, shall be perpendicular to the bearing surface within an admissible inward-outward deviation of 1 mm.

If the side walls of the sole are built in two parts, it shall be ensured that no part of the lower area of the sole protrudes beyond the upper profile.

4.3.4 Side walls at boot heel

The lateral side walls of the sole at the boot heel, up to a distance of at least

type A: 70 mm;

type C: 50 mm

from the heel end, shall be perpendicular to the bearing surface, or tapered inwards — outwards between 0° and 10° up to a height of 14 mm.

No part of the sole shall project beyond the 10° side wall limitation up to a height of 14 mm, between

type A: 70 mm and 85 mm;

type C: 50 mm and 65 mm.

If lateral grooves of more than 2 mm depth are present at the heel, see Figure 6, supports at least complying with Figure 7 shall remain.

Dimensions in millimetres

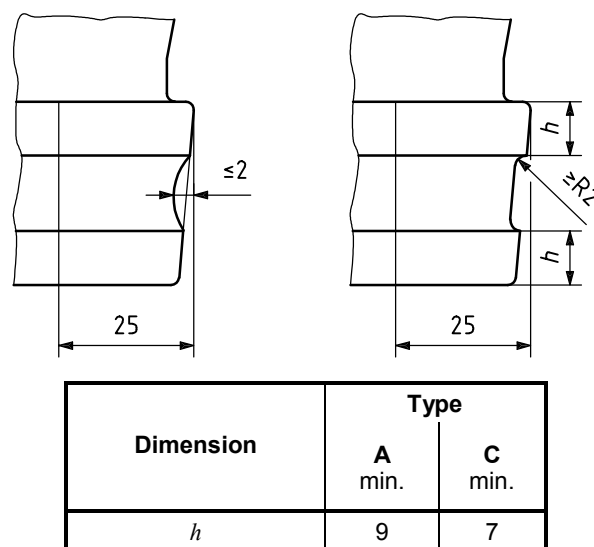
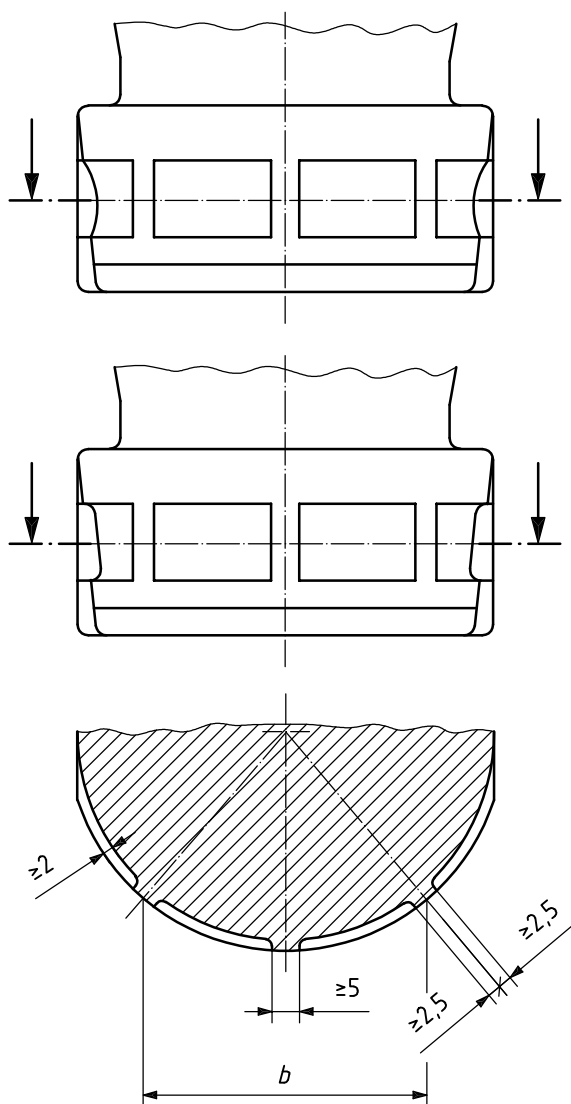

Figure 6 — Lateral grooves at heel

Dimensions in millimetres



Dimension	Type	
	A	C
<i>b</i>	45 ± 1	40 ± 1

Figure 7 — Lateral supports at heel

4.3.5 Free spaces

4.3.5.1 Requirements

4.3.5.1.1 The boot shell in the front of the boot along the arcs with a radius of

type A: $(41,5 \pm 3,5)$ mm;

type C: (35 ± 3) mm

shall lie outside free space 1 (see Figure 8).

Dimensions in millimetres

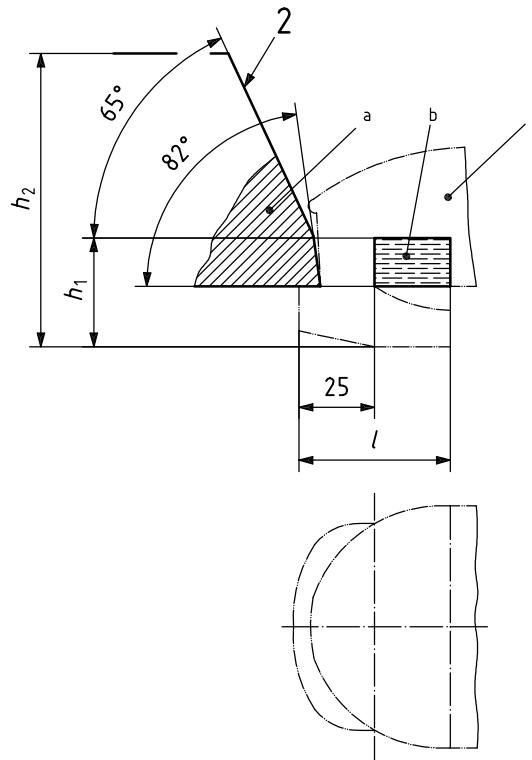

Dimension	Type	
	A min.	C min.
h_1	33	29
h_2	100	80
l	50	44

Key

- 1 sample boot
- 2 cone
- a Free space 1.
- b Free space 2.

Figure 8 — Free spaces at boot toe

4.3.5.1.2 Within free space 2 (see Figure 8), the arcs with radius of

type A: $41,5 \text{ mm} \pm 3,5 \text{ mm}$;

type C: $35 \text{ mm} \pm 3 \text{ mm}$

(see Figure 1 and Figure 2, section A-A) shall be continued as an arc without discontinuity, providing a smooth transition to the sides of the shaft, between

type A: 25 mm and 50 mm;

type C: 25 mm and 44 mm

condition is fulfilled when the curvature of the shell within free space 2 remains convex (according to Figure 9) in both horizontal and vertical planes. However, discontinuities are acceptable provided that they do not hinder the releasing movement of the binding.

Symmetry between both sides of the same boot is not required.

Dimensions in millimetres

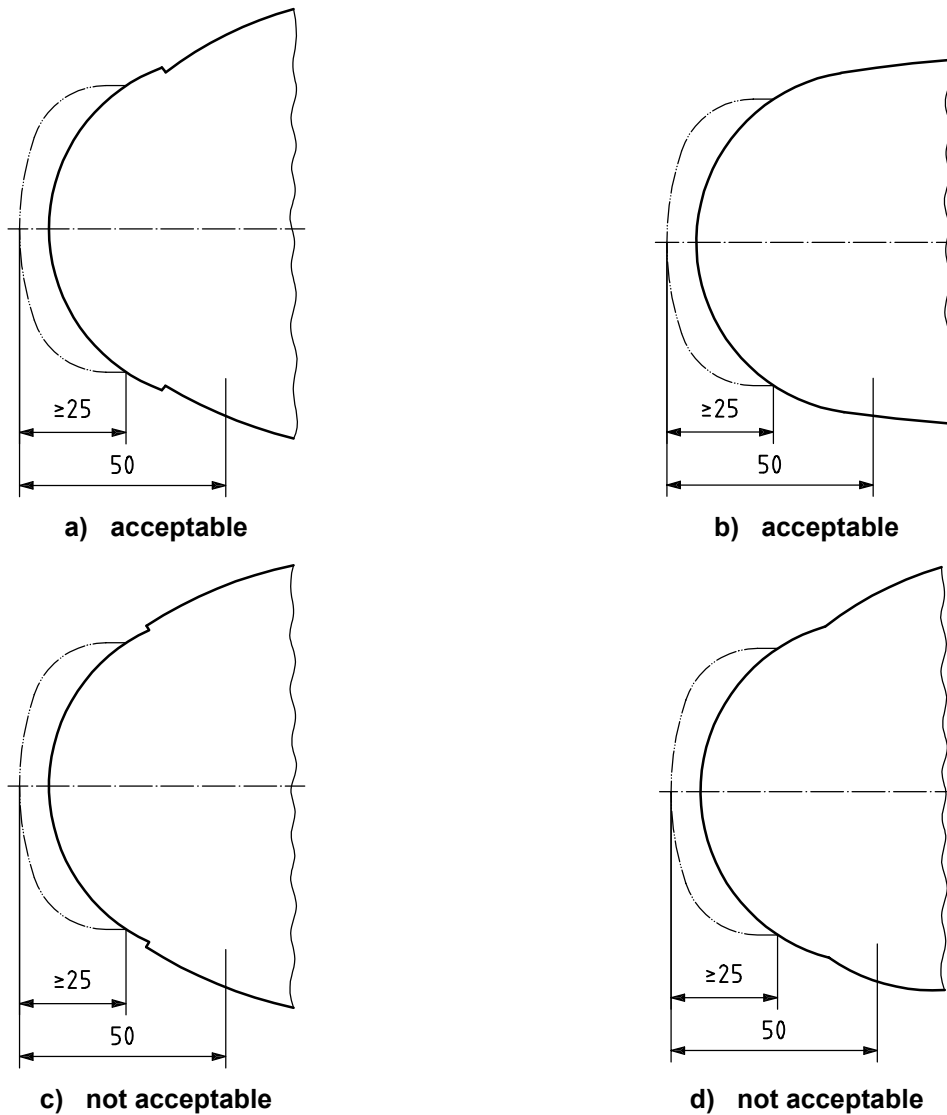

Figure 9 — Examples of curvature of the shaft in free space 2

4.3.5.1.3 The boot shell at the rear of the boot along the arcs with a radius of

type A: (35^{+6}_{-2}) mm;

type C: (27 ± 3) mm

shall lie outside free spaces 3 and 4 (see Figure 10) available for ski-binding and for handling boot and binding.

Dimensions in millimetres

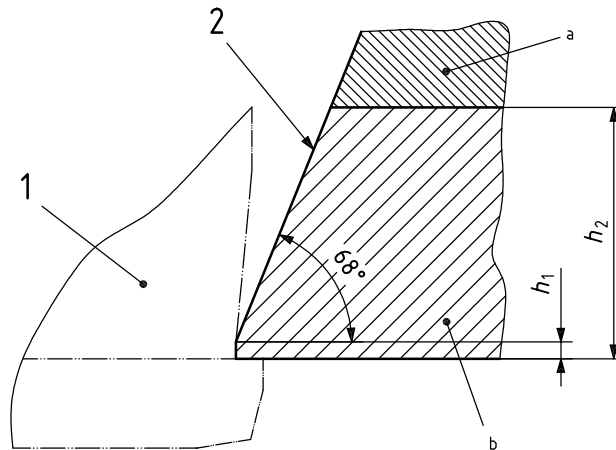

Dimension	Type	
	A	C
h_1	6 min.	5 min.
h_2	105	90
Width symmetrical to the median plane	50	45

Key

- 1 sample boot
- 2 cone

- a Free space 3, for handling boot and binding.
- b Free space 4, for ski-binding.

Figure 10 — Free space and rear interface for ski-binding at boot heel

4.3.5.2 Test methods

4.3.5.2.1 Measuring free space at boot toe

Place the boot with its front part

type A: min. 80 mm;

type C: min. 75 mm

on a measuring plane. Slide the test body (see Figures 11 and 12) on this plane from the front over the front interface.

Check whether the sole height exceeds the maximum value of

type A: (19 ± 1) mm;

type C: $(16,5 \pm 1,5)$ mm

and whether the requirement for free space for the binding is met.

Where the requirements are not met, ensure that the upper edge of the boot sole is in contact with the lower side of the horizontal height-recess (e.g. by placing distance-plates under the low-friction zone of the boot).

Dimensions in millimetres

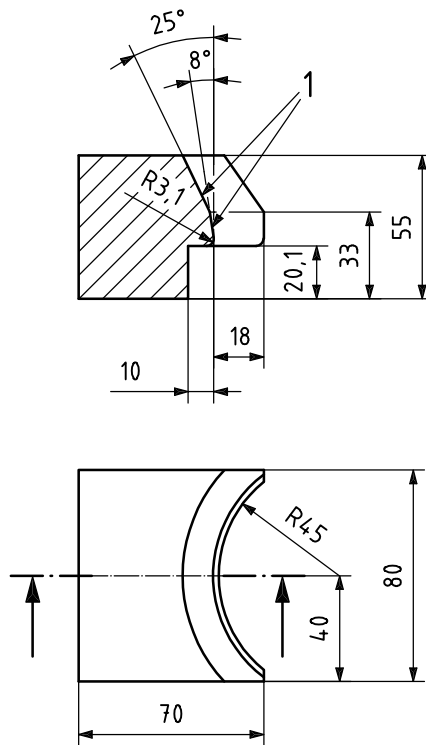

Key
1 concentric cones

Figure 11 — Test body for the free space at boot toe, type A

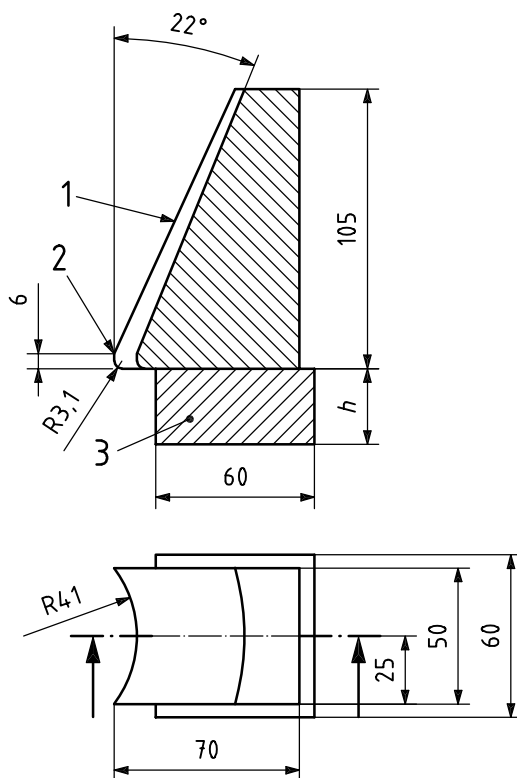

Key

- 1 cone (concentric with the cylinder)
- 2 cylinder
- 3 supporting blocks, where $h = 29,1; 30,1; 31,1$

Figure 13 — Test body for free space at rear of boot, type A

Dimensions in millimetres

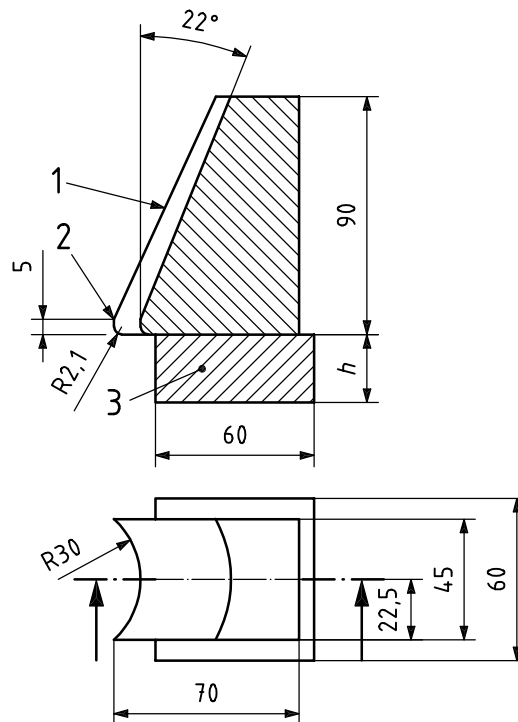
**Key**

- 1 cone (concentric with the cylinder)
- 2 cylinder
- 3 supporting blocks, where $h = 25,6; 27,6; 29,6$

Figure 14 — Test body for free space at rear of boot, type C**4.3.6 Interfaces****4.3.6.1 Material****4.3.6.1.1 Hardness**

The hardness of the material at the toe and heel binding interfaces for adult boots (see Figures 15 and 16) shall not be less than Shore D hardness 50¹⁾, measured at a temperature of (23 ± 2) °C.

The hardness of the material in contact with the antifriction device of children's boots shall not be less than Shore D hardness 50¹⁾.

The hardness of the binding interface (see Figures 15 and 16) for children's boots shall not be less than Shore D hardness 45¹⁾.

Testing is in accordance with ISO 868.

1) This requirement applies one year after publication.

4.3.6.1.2 Antifriction

4.3.6.1.2.1 Requirement

The coefficient of dynamic friction at the toe (see Figure 15) and heel binding interfaces (see Figure 16) between the boot material and a low-friction element of polytetrafluoroethylene (PTFE) shall be $\leq 0,1$.

If the material is identical to the material of the low friction zone, no testing is necessary.

If the materials are different, test in accordance with 4.3.6.1.2.2.

4.3.6.1.2.2 Test method

Inject a test specimen in the form of a plate (dimensions greater than or equal to those of the low friction zone) or of a part of the sole with the low friction zone of the diverging material.

Test the coefficient of friction according to 4.3.9.2.3.

Dimensions in millimetres

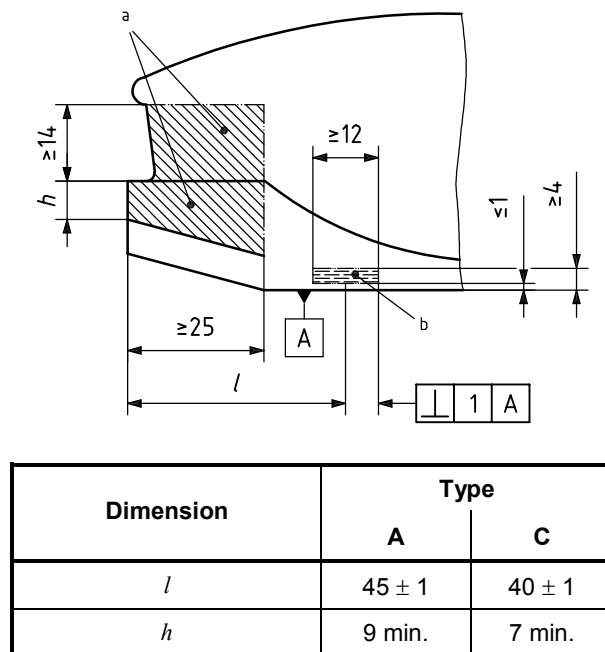

a Front interface.

b Interface location for adjustment device pushing rod test.

Figure 15 — Front interface and interface location for adjustment device pushing rod test

4.3.6.2 Front interface

At the front interface (see Figure 15),

- a) no material in the sole shall protrude perpendicular to the vertical surfaces;
- b) the profile of the shell in the 82° to 90° space can be straight or convex in any vertical plane providing the profile stays within the 82° to 90° limit.

4.3.6.3 Interface for the toe locking mechanism of the adjustment device

On both sides of the boot soles, an interface for the adjustment device pushing rod as shown in Figure 15 (footnote^b) shall be available.

This area shall be parallel to the median plane and shall lie at the same height on both sides of the sole.

Bindings for which the release adjustment test can be carried out by applying a lateral force on the surface should be conceived so as not to interfere with the application of this force.

NOTE This test method is only one among many.

4.3.6.4 Interface for the heel locking mechanism of the adjustment device

On both sides of the boot shell an interface for the locking mechanism of the adjustment device as shown in Figure 16 shall be available.

NOTE This method for locking the binding by means of a mechanism is only one among many.

The shaded areas in Figure 16 shall correspond to the outer shell of the ski boot, but shall not contain any edges or contain any protruding or set back areas.

Dimensions in millimetres

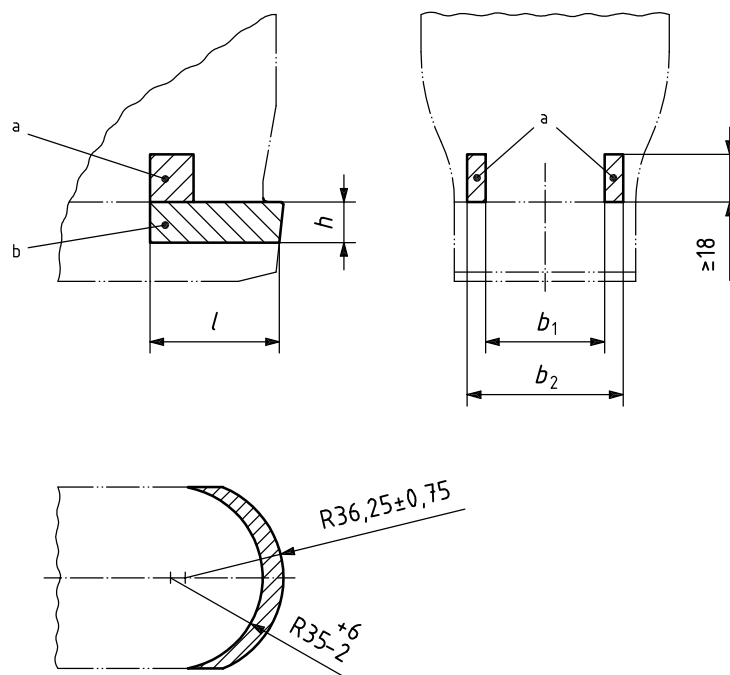

Dimension	Type	
	A	C
b_1	45^{+1}_0	45^{+1}_0
b_2	65^{+1}_0	59^{+1}_0
l	26 min.	25 min.
h	9 min.	7 min.

a Interface location for locking mechanism of adjustment device.

b Rear interface.

Figure 16 — Interface location for locking mechanism of adjustment device and low friction zone of rear interface

4.3.7 Bevelled areas

A tread pattern is permitted in the front area and the rear bevelled area.

4.3.8 Bearing surface at heel

4.3.8.1 Closing at the heel part

4.3.8.1.1 Requirements

The bearing surface shall be suitable for closing the heel part and shall allow longitudinal elastic travel of the binding.

4.3.8.1.2 Test method (penetration test)

Bring a test cylinder, length 40 mm and diameter 20 mm, on to the heel bearing surface. Set the zero with unloaded cylinder and apply a load of

type A: 400 N;

type C: 250 N

perpendicular to the boot. See Figure 17.

After 60 s the cylinder shall not have penetrated into the surface more than 2,5 mm.

Dimensions in millimetres

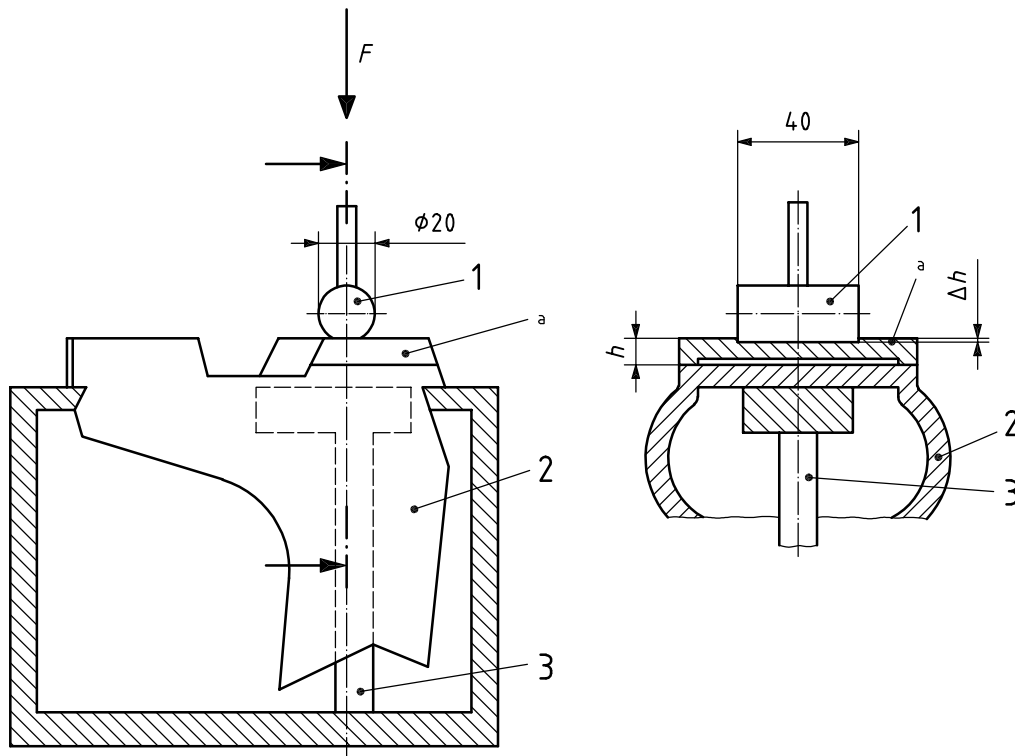

Key

- 1 test cylinder
- 2 sample boot
- 3 support to avoid sole bending
- F* test load
- a* Heel-bearing surface.

Figure 17 — Penetration test

4.3.8.2 Correct fit**4.3.8.2.1 Requirements**

The bearing surface shall provide a correct fit on the bearing plate of the binding.

4.3.8.2.2 Test methods**4.3.8.2.2.1 Penetration test**

This is carried out in accordance with 4.3.8.1.2.

4.3.8.2.2.2 Cylinder test

Move a test cylinder of 10 mm diameter and 20 mm length within the peripheral zone of

type A: 13 mm;

type C: 10 mm

see Figures 20 and 21. The test shall not reveal a variation in height greater than 1,5 mm in the longitudinal axis of the boot.

4.3.8.3 No hindrance to sideways movement**4.3.8.3.1 Requirements**

There shall be no hindrance to sideways movement of the sole if the binding releases.

4.3.8.3.2 Test methods

Penetration test, carried out in accordance with 4.3.8.1.2.

4.3.8.4 Proper function of ski-brakes**4.3.8.4.1 Requirements**

There shall be no interference with proper functioning of ski-brakes.

4.3.8.4.2 Test method**4.3.8.4.2.1 Penetration test**

This is carried out in accordance with 4.3.8.1.2.

4.3.8.4.2.2 Cylinder test

Move a test cylinder of 5 mm diameter and of length greater than the breadth of the sole along the longitudinal axis of the boot and later a test cylinder of 5 mm diameter and a length of 35 mm in the area between

type A: 25 mm and the value of dimension l_2 of Figure 1;

type C: 25 mm and the value of dimension l_2 of Figure 2

from the heel end. Both tests shall not reveal a variation in height greater than 1,5 mm along this axis.

4.3.8.5 Material other than TPU

4.3.8.5.1 Requirements

If a material other than TPU (thermoplastic polyurethane) is used in the heel part of the boot, there shall be at least one longitudinal low friction area to act as a bearing surface for the ski-brake as shown in Figure 18.

These boots shall fulfil the requirements of 4.3.9.1.1.

Dimensions in millimetres

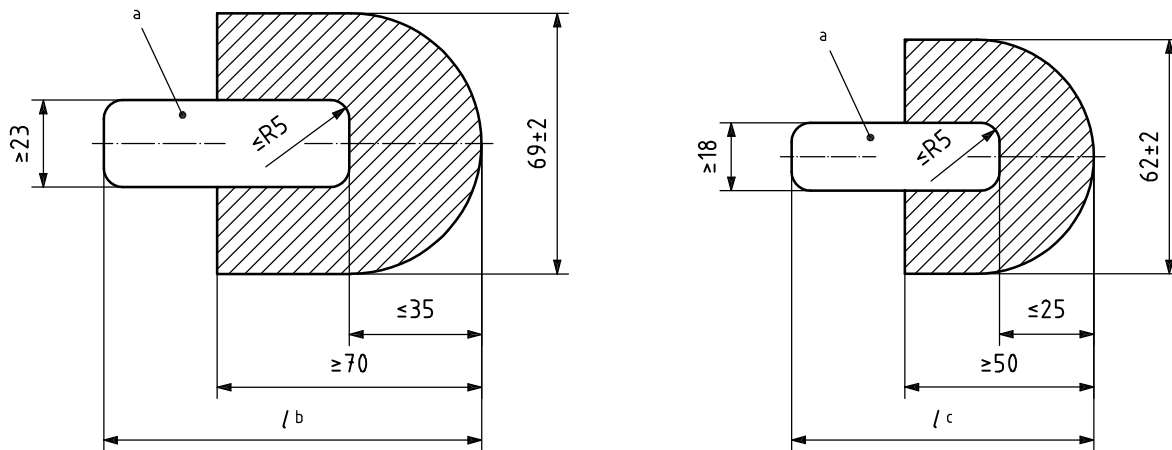

- a Non-profiled area may be 0,5 mm maximum deeper than profiled area and shall have the properties of 4.3.9.
- b See Figure 1.
- c See Figure 2.

Figure 18 — Bearing surfaces at the heel

4.3.8.5.2 Test method

These boots shall undergo the test in accordance with Figure 19.

Dimensions in millimetres

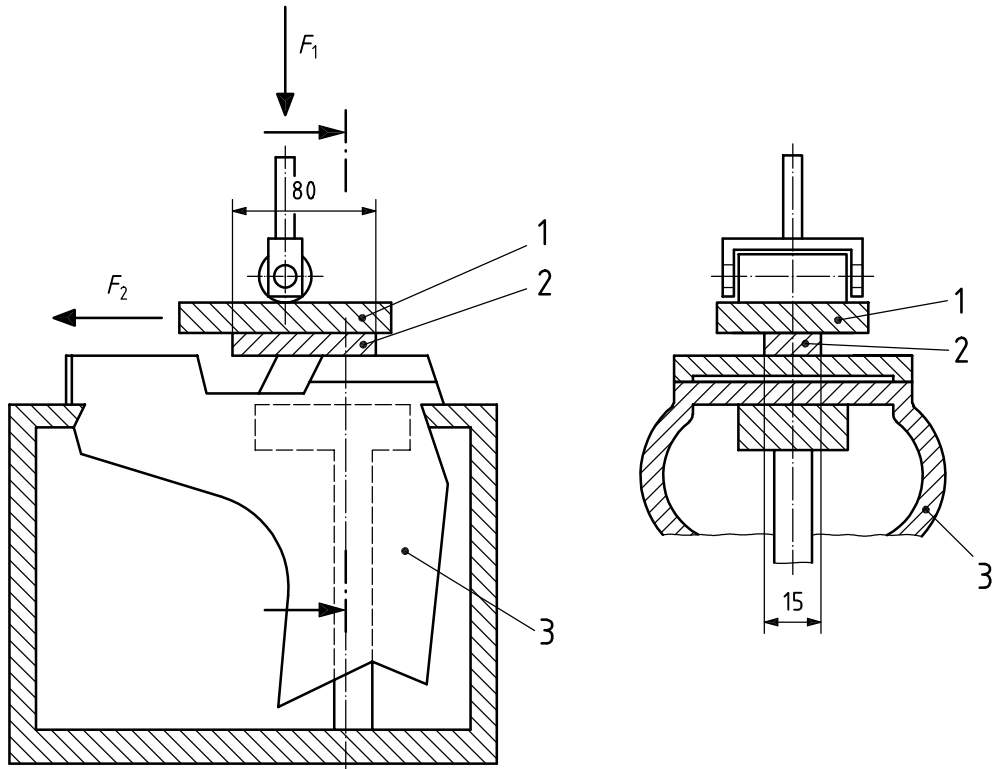

Key

- 1 support of low-friction element
- 2 low-friction element [same characteristics as 4.3.9.2.2 b) except wide and long dimensions which are respectively 15 mm and 80 mm]
- 3 sample boot

- F_1 Pre-force.
- F_2 Measuring force.

Figure 19 — Low-friction test

4.3.8.6 Horseshoe-shaped bearing surfaces

Horseshoe-shaped bearing surfaces shall comply with Figures 20 and 21.

Dimensions in millimetres

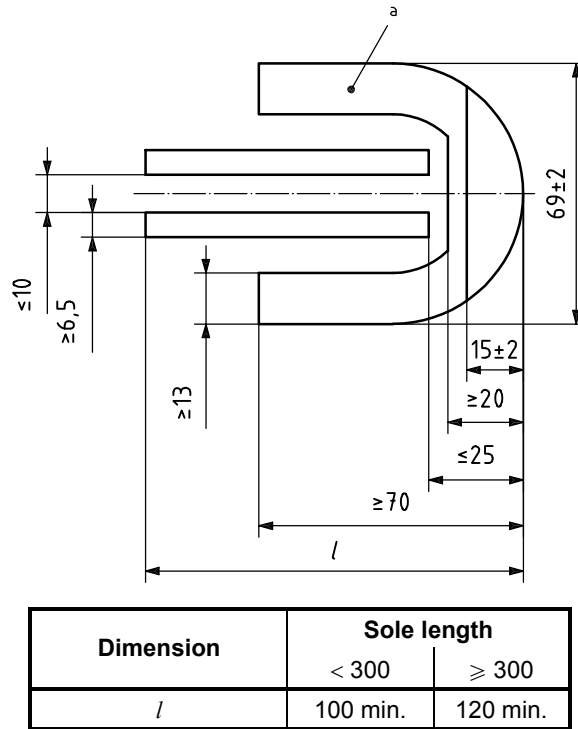

a Peripheral zone.

Figure 20 — Example of minimum bearing surface at heel, type A

Dimensions in millimetres

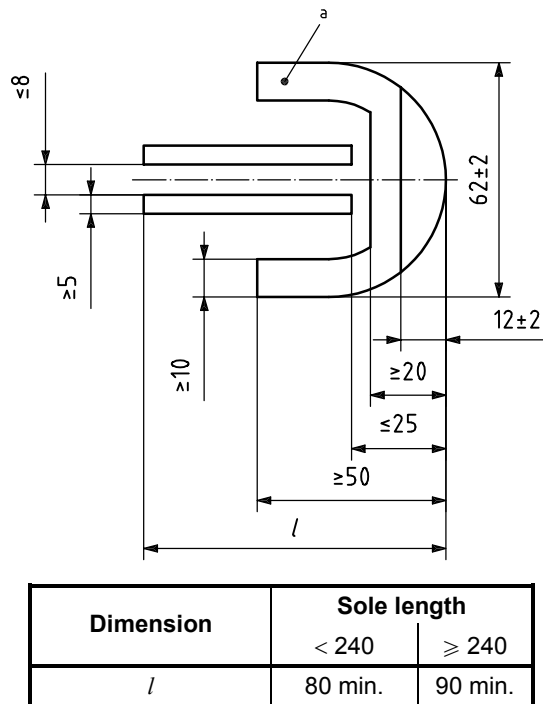

a Peripheral zone.

Figure 21 — Example of minimum bearing surface at heel, type C

4.3.9 Low-friction zone

4.3.9.1 Requirements

4.3.9.1.1 The coefficient of dynamic friction between the low-friction zone of the boot and a low-friction element of polytetrafluoroethylene (PTFE) shall have a maximum value of 0,10 rounded off to two decimal places.

4.3.9.1.2 No material that would interfere with side-to-side movement of the boot shall protrude below the low-friction zone.

4.3.9.2 Test method

4.3.9.2.1 Principle

The coefficient of dynamic friction is determined by the ratio of the force F_1 , necessary to move a low-friction element over the low-friction zone of the boot, to the test load F_2 , which is applied to the low-friction element.

4.3.9.2.2 Test equipment and conditions

The following test equipment and conditions shall be required.

- a) Six sample boots of at least three different sizes, stored for at least 14 d with the last 12 h of storage before the test under standard atmosphere.
- b) Low-friction element, minimum 100 mm wide, 40 mm long, minimum 1 mm thick of peeled PTFE with the following characteristics:
 - 1) density, in accordance with ISO 1183:1987, method A, of $2,18 \text{ g/cm}^3 \pm 3 \%$;
 - 2) mean tensile stress, in accordance with ISO 527-1 but with a specimen in accordance with Figure 22, $\geq 28,8 \text{ N/mm}^2$;
 - 3) mean percentage elongation, in accordance with ISO 527-1 but with a specimen in accordance with Figure 22, ≥ 300 ;
 - 4) mean ball-indentation hardness, in accordance with ISO 2039-1:2001, method B, $\geq 22,8 \text{ N/mm}^2$;
 - 5) surface profile $< 6 \text{ }\mu\text{m}$.

NOTE The low-friction element may be used for more than 30 measurements until marks of abrasion are visible.

- c) Standard atmosphere: 23/50 or 20/65, in accordance with ISO 554.
- d) Test load F_2 :
 - Type A: $500 \text{ N} \pm 5 \text{ N}$;
 - Type C: $300 \text{ N} \pm 5 \text{ N}$
- e) Measuring distance: 8 mm.
- f) Relative speed of the boot to the low-friction element $1 \text{ mm/s} \pm 0,2 \text{ mm/s}$.

Dimensions in millimetres

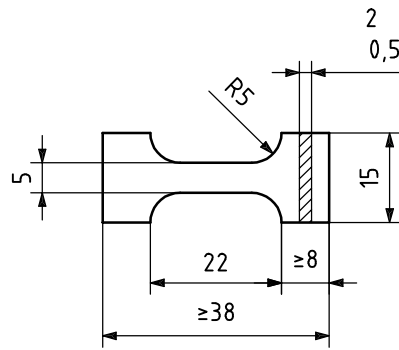

Figure 22 — PTFE specimen

4.3.9.2.3 Procedure

Submit the low-friction element to 10 preliminary measurements, which are not taken into account for the evaluation.

Clean the low-friction zone of the sample boot using neutral soap and hot water, rubbing with a soft brush. Allow to dry. After cleaning, the low-friction zone shall be free from grease and soap.

Carry out five measurements, the first of which is ignored, on each sample boot. Deformation of the sole greater than 1 mm, which can be avoided by using an appropriate support (see Figure 23), is not permitted.

The measurement error for the four significant measurements shall not exceed $\pm 5\%$.

Clean the low-friction element before measuring the next sample boot by rubbing with a clean soft cloth. After cleaning, the low-friction element shall be free from grease.

Determine the coefficient of dynamic friction by taking the mean value of the 24 measurements (6 boots \times 4 measurements each).

Dimensions in millimetres

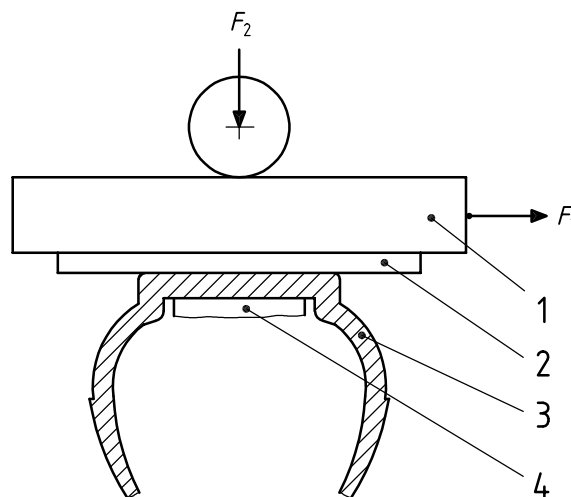

Key

- 1 low-friction element support
- 2 low-friction element
- 3 sample boot
- 4 support to prevent boot deformation

- F_1 Force necessary to move a low-friction element over the low-friction zone.
- F_2 Force applied to the low-friction element.

Figure 23 — Coefficient of dynamic friction test

4.3.10 Style of boot shell

In Figures 1 and 2, sections A-A and B-B, any style of boot shell (exterior surface) is admissible, provided

- it is symmetrical to the median plane;
- in section A-A, the curvature at any point up to a distance of minimum 25 mm stays within the limits of
 - type A: $41,5 \text{ mm} \pm 3,5 \text{ mm}$;
 - type C: $35 \text{ mm} \pm 3 \text{ mm}$;
- in section B-B, the curvature at any point up to a distance of
 - type A: minimum 26 mm;
 - type C: minimum 25 mm;
- stays within the limits of
 - type A: $35 \text{ mm} \begin{smallmatrix} +6 \\ -2 \end{smallmatrix} \text{ mm}$;
 - type C: $27 \text{ mm} \pm 3 \text{ mm}$.

4.3.11 Mounting point

The mounting point for positioning the binding on the ski shall be indicated by a line on each side of the lower surface of the boot as close as possible to the ski. This line shall be clearly visible and permanent. It shall not be less than 10 mm in length and shall not be more than

type A: 5 mm;

type C: 4 mm

from the middle of the boot sole length.

The deviation between left and right boot shall not be more than 1 mm.

5 Marking

Ski-boots that meet the requirements of this International Standard shall be marked as follows:

- a) reference to this International Standard, i.e. ISO 5355, excluding all other national references;
- b) name or trade-mark of the manufacturer or importer;
- c) letter symbol A or C for type of boot beside the mounting point, at least 5 mm high.

The letter shall be permanent and easily recognizable.

Annex A
(normative)

Mondopoint system ski-boot sizing and marking

A.1 Reference

This ski-boot sizing system is based on ISO 9407, using only the length of the foot, measured in centimetres.

A.2 Range of sizes

The range of sizes shall start with size 15,0 and end (optionally) with size 32,0.

A.3 Length intervals

The length intervals between sizes shall be multiples of 0,5 cm (i.e. the last figure of the size shall be 0 or 5).

Table A.1 — Lengths

Type A	Type C
	15,0
	15,5
	16,0
	16,5
	17,0
	17,5
	18,0
	18,5
	19,0
	19,5
20,0	20,0
20,5	20,5
21,0	21,0
21,5	21,5
22,0	22,0
22,5	22,5
23,0	23,0
23,5	23,5
24,0	24,0
24,5	24,5
25,0	25,0
25,5	
26,0	
26,5	
27,0	
27,5	
28,0	
28,5	
29,0	
29,5	
30,0	
30,5	
31,0	
31,5	
32,0	

Annex B (informative)

Dimensions and requirements of “2nd degree”

B.1 Dimensions

Figure 1	Radius of the sole heel	34,25 mm ± 0,75 mm 36,25 mm ± 0,75 mm
	Rounding radius (maximum)	3 mm 0,8 mm ± 0,3 mm
	Length of rear bevel	15 mm ± 2 mm
	Height of rear bevel	4 mm ± 1 mm
	Slope of the rear side of the sole	2,5 mm ± 0,5 mm
	Length of front bevel	30 mm ± 2 mm
	Height of front bevel	5 mm ± 1 mm
	Tolerance of perpendicularity at the front	1 mm
Figure 2	The dimensions correspond to those in Figure 1	

B.2 Requirements

4.3.1	Difference in sole length (maximum)	2 mm
4.3.3	Perpendicularity of the side walls at the toe	1 mm
4.3.4	Perpendicularity of the side walls at the heel	0° to 10°
	No projection of sole parts beyond	10°
4.3.5.1.2	Form of the boot shaft	
4.3.6.2 a)	No protrusions	
4.3.8.1 or 4.3.8.2 and 4.3.8.3	Bearing surface at heel	
4.3.8.2.2.2	Dimensions of test cylinder	10 mm diameter and 20 mm in length
	Variation in height	1,5 mm max.
4.3.9.1.2	No protrusion of material below the low-friction zone	
4.3.11	Mounting point, proximity to the ski, length	10 mm
	Distance from middle of sole length	5 (4) mm

