

INTERNATIONAL
STANDARD

ISO
5353

Second edition
1995-12-01

**Earth-moving machinery, and tractors and
machinery for agriculture and forestry —
Seat index point**

*Engins de terrassement, et tracteurs et matériels agricoles et
forestiers — Point repère du siège*



Reference number
ISO 5353:1995(E)

Foreword

ISO (the International Organization for Standardization) is a worldwide federation of national standards bodies (ISO member bodies). The work of preparing International Standards is normally carried out through ISO technical committees. Each member body interested in a subject for which a technical committee has been established has the right to be represented on that committee. International organizations, governmental and non-governmental, in liaison with ISO, also take part in the work. ISO collaborates closely with the International Electrotechnical Commission (IEC) on all matters of electrotechnical standardization.

Draft International Standards adopted by the technical committees are circulated to the member bodies for voting. Publication as an International Standard requires approval by at least 75 % of the member bodies casting a vote.

International Standard ISO 5353 was prepared by Technical Committee ISO/TC 127, *Earth-moving machinery*, Subcommittee SC 2, *Safety requirements and human factors*.

This second edition cancels and replaces the first edition (ISO 5353:1978), of which it constitutes a technical revision.

© ISO 1995

All rights reserved. Unless otherwise specified, no part of this publication may be reproduced or utilized in any form or by any means, electronic or mechanical, including photocopying and microfilm, without permission in writing from the publisher.

International Organization for Standardization
Case Postale 56 • CH-1211 Genève 20 • Switzerland

Printed in Switzerland

Earth-moving machinery, and tractors and machinery for agriculture and forestry — Seat index point

1 Scope

This International Standard specifies a method and the device for use in determining the position of the seat index point (SIP) for any kind of seat designed for earth-moving machinery as defined in ISO 6165, and tractors and machinery for agriculture and forestry as defined in ISO 3339-0.

This provides a uniform method for defining the location of the SIP in relation to a fixing point on the seat. The SIP may be determined on a seat by itself or with the seat located in its operating environment on the machine. The SIP is a characteristic of the seat; therefore, it may be specified by the seat manufacturer.

2 Normative references

The following standards contain provisions which, through reference in this text, constitute provisions of this International Standard. At the time of publication, the editions indicated were valid. All standards are subject to revision, and parties to agreements based on this International Standard are encouraged to investigate the possibility of applying the most recent editions of the standards indicated below. Members of IEC and ISO maintain registers of currently valid International Standards.

ISO 3339-0:1986, *Tractors and machinery for agriculture and forestry — Classification and terminology — Part 0: Classification system and classification.*

ISO 6165:1987, *Earth-moving machinery — Basic types — Vocabulary.*

3 Definitions

For the purposes of this International Standard, the following definitions apply.

3.1 seat index point; (SIP): Point on the central vertical plane of the seat as determined by the device shown in figure 1, when installed in the seat as specified in 5.3.

NOTES

1 The SIP is fixed with respect to the machine and does not move with the seat through its adjustment and/or oscillation range.

2 The SIP as established and defined by this International Standard may be considered, for operator work-place design purposes, to be equivalent to the intersection on the central vertical plane through the seat centreline of the theoretical pivot axis between a human torso and thighs.

3.2 fixing point: Point specified by the manufacturer to which the SIP is referenced.

See figures 2 and 3 for examples.

4 Multiple machine function seats

Some seats are designed to locate and fix an operator to perform more than one function with a given machine. Where a second position of the seat is provided because the machine or tractor has a second set of controls, the SIP of the seat has two locations relative to the machine or tractor, one for each position, as if there were two seats in the machine or tractor. The first location of the SIP shall be used for those International Standards appropriate to the first location and set of controls and the second location of the SIP shall be used for those International Standards appropriate to the second location and set of controls.

5 Technical requirements

5.1 Device for seat index point (SIP) determination

The device for determining the SIP shall comply with figure 1. The mass of the device shall be $6 \text{ kg} \pm 1 \text{ kg}$. The work surfaces of the device shall be of hardwood (sanded with 200 or finer grit paper or equivalent and polished) or equivalent material with the same performance to provide minimum friction with the muslin cloth in 5.3.1.

5.2 Adjustments when determining the seat index point (SIP)

When the relevant adjustments are a part of the seat and its suspension, the seat shall be adjusted according to the following sequential steps before determining the SIP.

5.2.1 Seat adjustment

All fore, aft, vertical and angular adjustments shall be placed in their centre position. When no centre position is possible, the nearest adjustment that will move the SIP device upward or rearward of centre shall be used.

5.2.2 Suspension system

Block the suspension system according to the manufacturer's instruction. If such instruction is not provided, block the suspension system at the midpoint of its oscillation range.

Non-adjustable suspension shall be blocked in the vertical position attained with the weighted device in place.

5.3 Seat index point (SIP) determination

The SIP shall be determined by using the device illustrated in figure 1 and applying the following procedures.

5.3.1 Seat preparation

Allow sufficient time to ensure that the seat reaches a room temperature of $20 \text{ °C} \pm 2 \text{ °C}$ before starting the measurement procedure.

Place the seat on a level surface.

Seat a $75 \text{ kg} \pm 10 \text{ kg}$ person in the seat twice for 1 min periods to flex the seat and back cushions. Al-

low the seat to remain unloaded for a minimum period of 5 min before starting the measurement procedure.

Cover the seat with a single layer of muslin cloth of sufficient size to prevent direct contact and minimize friction between the cushion surfaces and the measurement device. Take care to prevent the cloth from influencing the positioning of the device.

5.3.2 Device placement

Place the SIP device, without additional masses, laterally central on the seat cushion pushing against the back cushion (see figure 2). Ensure that the device is laterally controlled and level on the seat.

Add masses to bring the total mass of the device from $6 \text{ kg} \pm 1 \text{ kg}$ to $26 \text{ kg} \pm 1 \text{ kg}$; the vertical force centre of the added masses shall be 40 mm in front of the SIP mark on the horizontal section of the device (see figure 1).

To obtain a good fit between the seat cushion, the back cushion, and the SIP measuring device, alternately apply and release a horizontal rearward force of approximately 100 N at the location noted in figure 1, and rock the device from side to side.

Add further masses to bring the total mass of the device from $26 \text{ kg} \pm 1 \text{ kg}$ to $65 \text{ kg} \pm 1 \text{ kg}$ such that the vertical force centre of the additional masses is 40 mm in front of the SIP mark on the horizontal section of the device (see figure 1).

NOTE 3 A 75 kg operator approximates the 65 kg weighted device on the seat.

Repeat the alternate loading and releasing, and the rocking of the device, checking to make sure the device is laterally central and level on the seat.

5.3.3 Measurement

Make measurements on each side of the SIP measuring device at points an equal distance from the central vertical plane (see figure 2). Average the values. Record within $\pm 1 \text{ mm}$ the coordinate dimensions of the SIP from the fixing point on the seat assembly (see figure 3) that is defined by the manufacturer.

Some machines have seats which fulfil multiple functions, usually by rotating the seat. Functions may include using machine equipment or operating the machine in travel mode. For these cases, it may not be possible readily to calculate the location of the different SIPs relative to the fixing point. In these cases, repeat 5.2 and 5.3 for each of the positions.

5.4 Report

The test report shall include the following information:

- a) reference to this International Standard;
- b) a full description of any test conditions or adjustments different from those specified in this International Standard;
- c) a drawing or sketch of the seat assembly showing the coordinate dimensions between the fixing point and the SIP (see figure 3 for an example);
- d) description of the seat adjustment ranges available relevant to 5.2.

Dimensions in millimetres

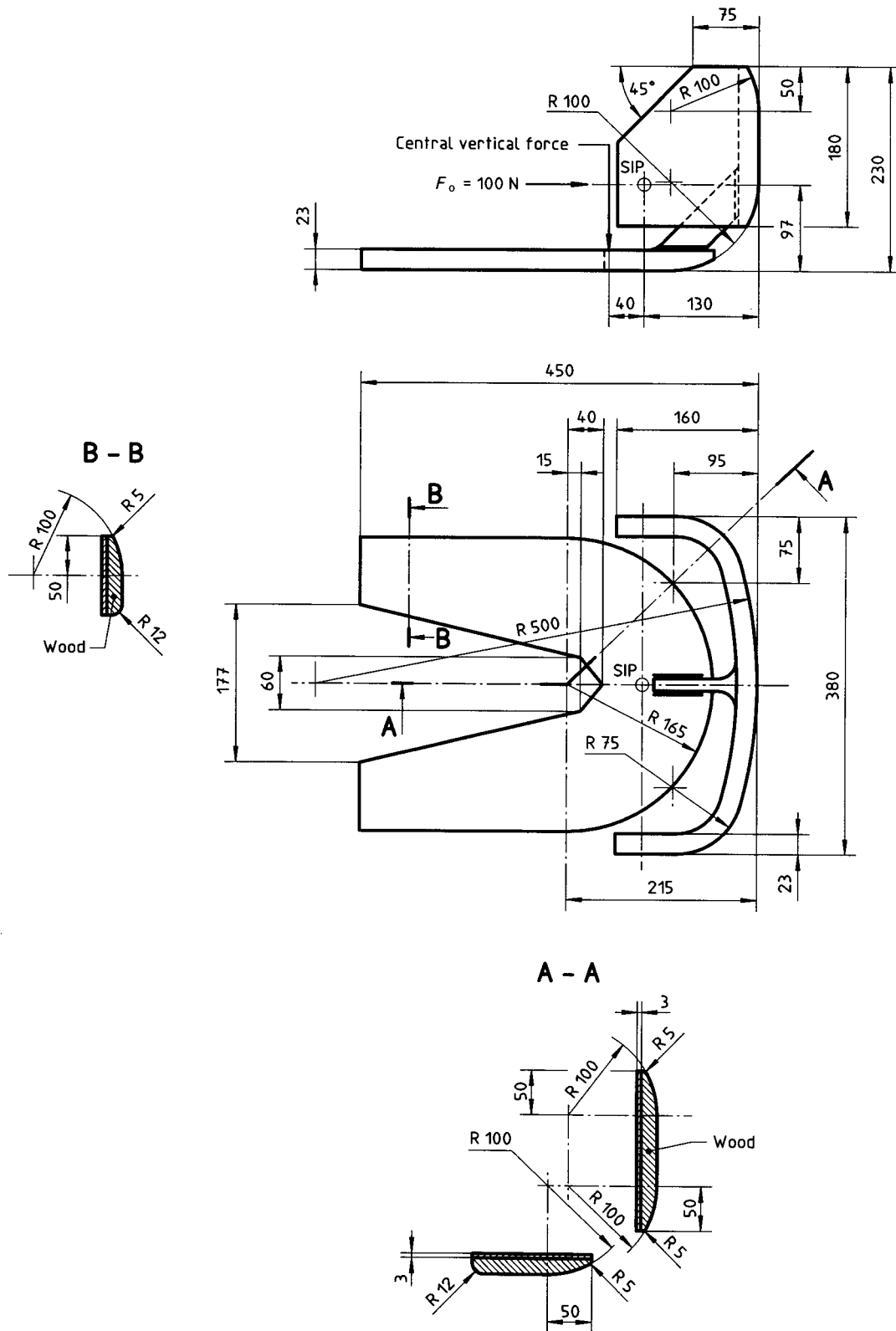

Figure 1 — Seat index point device

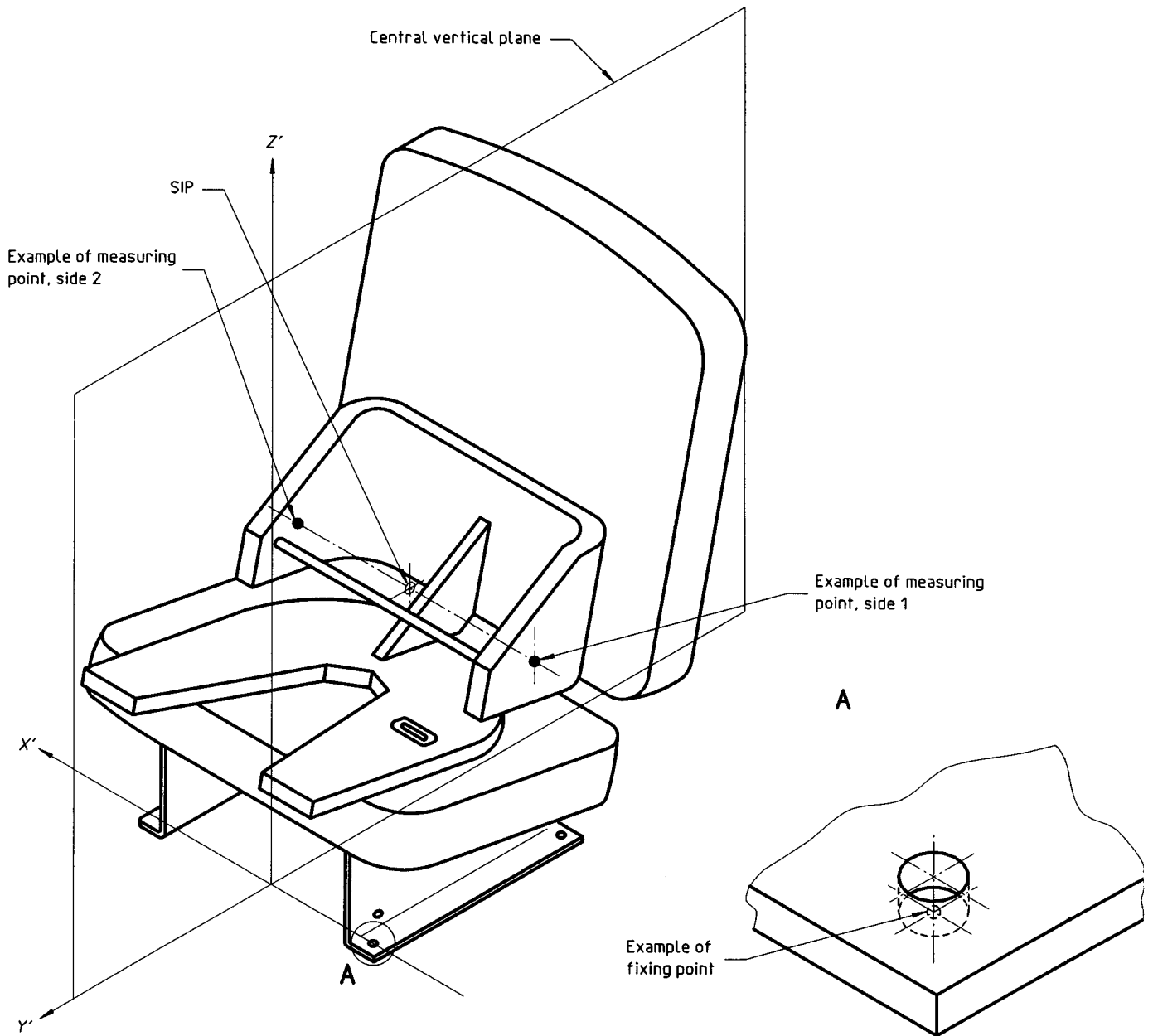

Figure 2 — Seat with SIP device

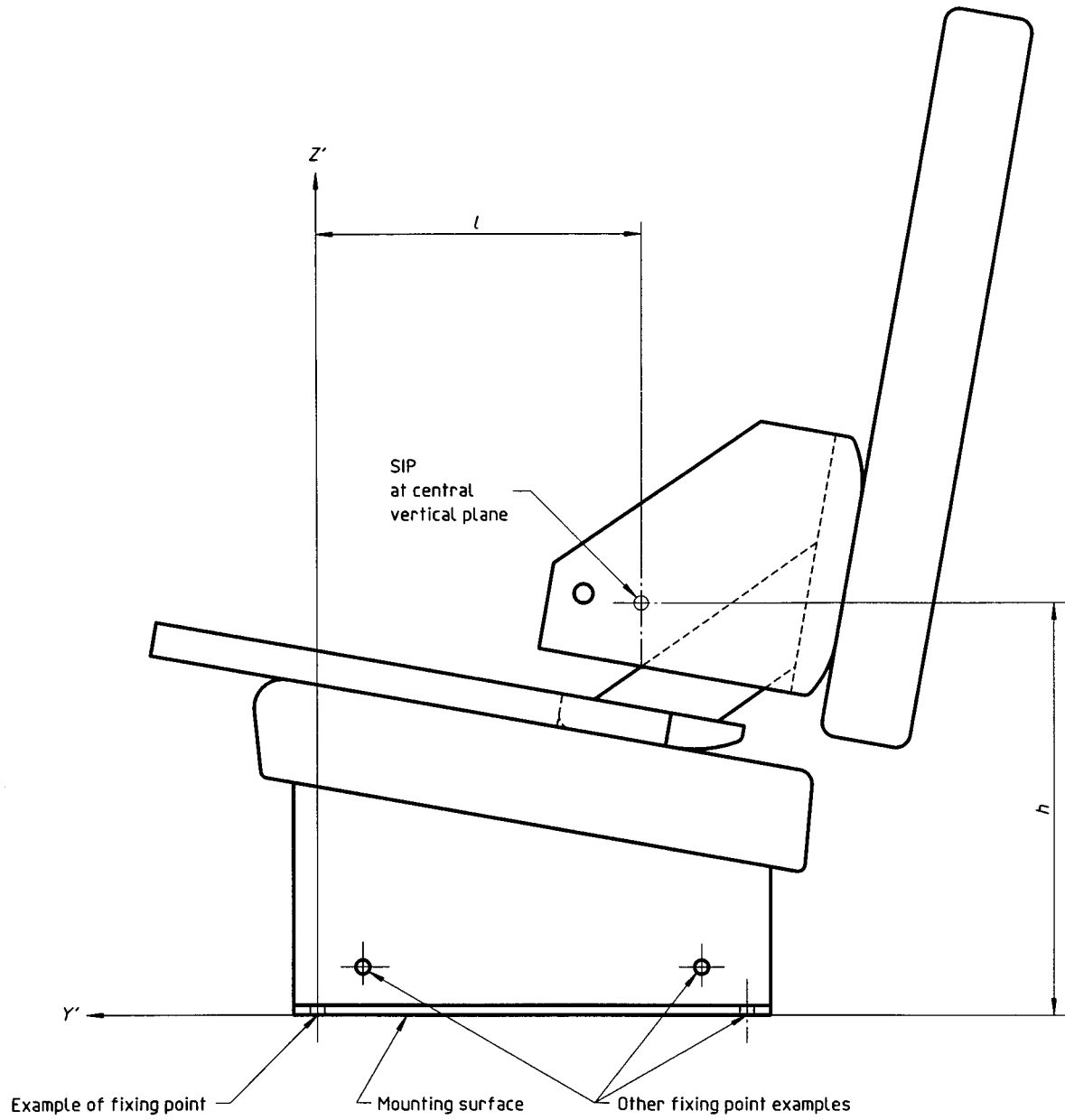

Figure 3 — SIP location

ICS 53.100; 65.060

Descriptors: earth-moving equipment, agricultural machinery, agricultural tractors, forest equipment, seats, ground vehicle seats, operator seats, tests, determination, seat index point.

Price based on 6 pages
