

# INTERNATIONAL STANDARD

**ISO**  
**5267-1**

Second edition  
1999-03-01

---

---

## **Pulps — Determination of drainability —**

### **Part 1: Schopper-Riegler method**

*Pâtes — Détermination de l'égouttabilité —  
Partie 1: Méthode Schopper-Riegler*



Reference number  
ISO 5267-1:1999(E)

**ISO 5267-1:1999(E)****Foreword**

ISO (the International Organization for Standardization) is a worldwide federation of national standards bodies (ISO member bodies). The work of preparing International Standards is normally carried out through ISO technical committees. Each member body interested in a subject for which a technical committee has been established has the right to be represented on that committee. International organizations, governmental and non-governmental, in liaison with ISO, also take part in the work. ISO collaborates closely with the International Electrotechnical Commission (IEC) on all matters of electrotechnical standardization.

Draft International Standards adopted by the technical committees are circulated to the member bodies for voting. Publication as an International Standard requires approval by at least 75 % of the member bodies casting a vote.

International Standard ISO 5267-1 was prepared by Technical Committee ISO/TC 6, *Paper, board and pulps*, Subcommittee SC 5, *Test methods and quality specifications for pulp*.

This second edition cancels and replaces the first edition (ISO 5267-1: 1979), of which it constitutes a minor revision. The main amendment is the addition of ISO 14487 to clause 6 (formerly clause 7) to specify the water used in the test.

ISO 5267 consists of the following parts, under the general title *Pulps — Determination of drainability*:

- *Part 1: Schopper-Riegler method*
- *Part 2: "Canadian Standard" freeness method*

Annexes A and B form an integral part of this part of ISO 5267.

© ISO 1999

All rights reserved. Unless otherwise specified, no part of this publication may be reproduced or utilized in any form or by any means, electronic or mechanical, including photocopying and microfilm, without permission in writing from the publisher.

International Organization for Standardization  
Case postale 56 • CH-1211 Genève 20 • Switzerland  
Internet iso@iso.ch

Printed in Switzerland

# Pulps — Determination of drainability — Part 1: Schopper-Riegler method

## 1 Scope

This part of ISO 5267 specifies a method for the determination of the drainability of a pulp suspension in water in terms of the Schopper-Riegler (SR) number.

The Schopper-Riegler test is designed to provide a measure of the rate at which a dilute suspension of pulp may be dewatered. It has been shown that the drainability is related to the surface conditions and swelling of the fibres, and constitutes a useful index of the amount of mechanical treatment to which the pulp has been subjected.

In principle, this method is applicable to all kinds of pulp in aqueous suspension. However, in practice, the Schopper-Riegler test provides acceptable results only if a sufficiently dense mat of fibres is formed on the wire screen. For this reason, the test is not recommended for some extremely short-fibred pulps, such as those from well-beaten hardwoods, as most of the fibres will pass through the wire screen, resulting in anomalous reduction of the SR number. The most reliable results are obtained within the range of 10 to 90 SR number.

The results of this test do not necessarily correlate with the drainage behaviour of a pulp material on a commercial paper machine.

**NOTE** A method for the determination of drainability in terms of the "Canadian Standard" freeness number is specified in ISO 5267-2:1980, *Pulps — Determination of drainability — Part 2: "Canadian Standard" freeness method*.

## 2 Normative references

The following standards contain provisions which, through reference in this text, constitute provisions of this part of ISO 5267. At the time of publication, the editions indicated were valid. All standards are subject to revision, and parties to agreements based on this part of ISO 5267 are encouraged to investigate the possibility of applying the most recent editions of the standards indicated below. Members of IEC and ISO maintain registers of currently valid International Standards.

ISO 4119:1995, *Pulps — Determination of stock concentration*.

ISO 14487:1997, *Pulps — Standard water for physical testing*.

## 3 Definition

For the purposes of this part of ISO 5267, the following definition applies.

### 3.1

#### **Schopper-Riegler number scale**

scale on which a discharge of 1 000 ml corresponds to a SR number of zero and zero discharge to a SR number of 100

### 3.2

#### **stock**

aqueous suspension of disintegrated pulp

## 4 Principle

Draining, through a fibre mat formed during the test on a wire screen, of a given volume of pulp in aqueous suspension into a funnel provided with a bottom and a side orifice. Collection of the discharge from the side orifice in a measuring cylinder, graduated in Schopper-Riegler numbers.

## 5 Apparatus

Ordinary laboratory apparatus and

**5.1 Schopper-Riegler apparatus**, as described in annex A.

Instructions for maintenance of the apparatus are given in annex B.

**5.2 SR measuring cylinder**, graduated in Schopper-Riegler numbers.

## 6 Preparation of sample

Take a sample of aqueous suspension of disintegrated pulp. If the concentration is not known exactly, dilute the suspension to a mass fraction of approximately 0,22 % with standard water in accordance with ISO 14487 (see note 2), and determine the stock concentration (mass fraction) in accordance with ISO 4119. Then dilute the suspension to a mass fraction of  $0,2 \% \pm 0,002 \%$  and adjust the temperature to  $20,0\text{ }^{\circ}\text{C} \pm 0,5\text{ }^{\circ}\text{C}$  (see note 3). Throughout the preparation of the sample, take care to avoid the formation of air bubbles in the suspension.

With time, an aqueous pulp suspension, withdrawn from the stock preparation system or laboratory pulp evaluation equipment, can undergo a change in Schopper-Riegler number. To avoid the effect of this reversion phenomenon, pulp suspensions subjected to testing more than 30 min after sampling shall first be treated in the disintegration apparatus for 6 000 revolutions of the propellor, at or near the stock concentration specified for the SR test.

**NOTE 1** The test result is sensitive to the quantity of pulp fines, or "crill", in the suspension. Thickened pulp samples may lose some of this fibre fraction. To avoid such losses during the course of thickening, the filtrate should be recirculated through the pulp-pad until the filtrate is clear, and the pulp redispersed by disintegrating as described in the previous paragraph. This procedure should be used to concentrate dilute pulp suspension to the mass fraction required for the Schopper-Riegler test.

**NOTE 2** As the drainage of a pulp suspension is affected considerably by dissolved solid and the pH of the water, standard water in accordance with ISO 14487 should be used throughout the test.

**NOTE 3** Where necessary for climatic reasons, a temperature of  $25\text{ }^{\circ}\text{C} \pm 5\text{ }^{\circ}\text{C}$  may be applied, provided that this is noted in the test report. In any case, during the test the basic temperature chosen should be kept constant within  $\pm 0,5\text{ }^{\circ}\text{C}$ .

## 7 Procedure

Clean the funnel and drainage chamber of the Schopper-Riegler apparatus (5.1 ) thoroughly and finally rinse with water. Place the drainage chamber in the seat of the funnel. Adjust the temperature of the apparatus by rinsing it with water at  $20,0 \pm 0,5\text{ }^{\circ}\text{C}$  (see note 3 in clause 6).

Place the sealing cone in the closed position and position the SR measuring cylinder (5.2) beneath the side orifice.

Whilst stirring, transfer  $1\ 000\text{ ml} \pm 5\text{ ml}$  of homogeneous pulp suspension to a clean measuring cylinder. Mix the sample by closing the top of the cylinder by hand and turning it end-over-end for two cycles. Avoid introducing air into the stock at this stage.

Pour the sample rapidly but smoothly into the drainage chamber. Direct the stream against the shaft and the wings of the sealing cone to avoid a vortex.

Raise the sealing cone 5 s after all the pulp suspension has been added. Read the SR number on the measuring cylinder to the nearest unit when no more water drips from the side orifice.

## 8 Expression of results

Carry out two determinations on each sample. Duplicate determinations which differ by more than 4 % shall be repeated.

## 9 Test report

The test report shall include the following information:

- a) a reference to this part of ISO 5267;
- b) all indications necessary for complete identification of the sample;
- c) the test temperature, if other than 20 °C;
- d) the results, expressed in Schopper-Riegler numbers;
- e) any unusual features observed in the course of the test;
- f) any operations not specified in this part of ISO 5267, or in the International Standard to which reference is made, or regarded as optional, which might have affected the results.

## Annex A (normative)

### The Schopper-Riegler apparatus

**A.1** The Schopper-Riegler apparatus (see figure A.1) comprises a drainage chamber equipped with a wire screen, a sealing cone, and a funnel mounted on a suitable support. All parts are made of non-corrodible material. The drainage chamber is a cylinder having an internal diameter of 137 mm; at its lower end is a 45° tapered section, followed by a cylindrical part having a diameter of 112,9 mm  $\pm$  0,1 mm (cross-sectional area 100 cm<sup>2</sup>). The tapering section forms a seat for the sealing cone. The wire screen is of phosphor bronze, and fits tightly into the cylinder 25 mm below the taper. It is plane, is mounted perpendicular to the cylinder axis, and has a thickness of 0,40 mm. It has 24 weft and 32 warp meshes per 10 mm, the weft strands having a thickness of 0,17 mm and the warp strands 0,16 mm.

**A.2** The sealing cone (see figure A.1, and figure A.2) has an external diameter of 120 mm and its tapered surface is at 55° to the vertical. The sealing cone is fitted to a vertical shaft having an external diameter of 20 mm. A vent having a diameter of 10 mm runs axially through the sealing cone and the shaft, to permit the passage of air when the sealing cone is raised. The shaft is provided with two wings placed diametrically and vertically, to prevent vortices in the pulp suspension. The seal consists of a rubber ring of 30° Shore hardness. The sealing cone shall be raised at a constant rate of 110 mm/s  $\pm$  10 mm/s.

**A.3** The funnel (see figure A.1, 4) has an upper conical section which provides a seating for the drainage chamber, and enables the sealing cone to be centred accurately in the chamber. This conical section is followed by a cylindrical section, having a cross-sectional area of 100 cm<sup>2</sup> and a height of 35 mm. Near the top of this section is a vent for equalization of the air pressure. The cylindrical section has three grooves, which determine the location of the spreader cone.

The lower part of the funnel is conical, having a cone angle of 40,0°, and it terminates in a separate bottom orifice having the dimensions specified in figure A.3. The diameter of the cylindrical section of the bottom orifice is so chosen that 1 000 ml of water at 20,0 °C  $\pm$  0,5 °C poured into the funnel drains out in 149 s  $\pm$  1 s. This necessitates a diameter of about 2,32 mm (see B.2.5).

**A.4** The side orifice (see figure A.1, 7) has an internal diameter of 16,0 mm  $\pm$  0,1 mm and an external diameter of 19,0 mm  $\pm$  0,1 mm. It penetrates the funnel at an angle of 49,0° to the vertical. The upper end of the side orifice is cut at 12,0° to the central axis of the funnel, and the overflow edge is as close as possible to the centre of the funnel. In this position, the volume between the lower edge of the bottom orifice and the overflow edge of the side orifice is 7,5 ml to 8,0 ml. The level of the overflow edge is adjustable. A detachable spreader cone (see figure A.4) is placed in the funnel to prevent splash from entering the side orifice. One of the supporting legs of the spreader cone is set diametrically to the side orifice.

**A.5** The measuring cylinder is so graduated that it provides a direct reading of the Schopper-Riegler number, with a volume of 1 000 ml corresponding to zero SR number, and a volume of 0 ml corresponding to 100 SR units. The distance between two graduations shall be at least 1,5 mm, corresponding to a volume of 10 ml equal to one SR number.

Dimensions in millimetres

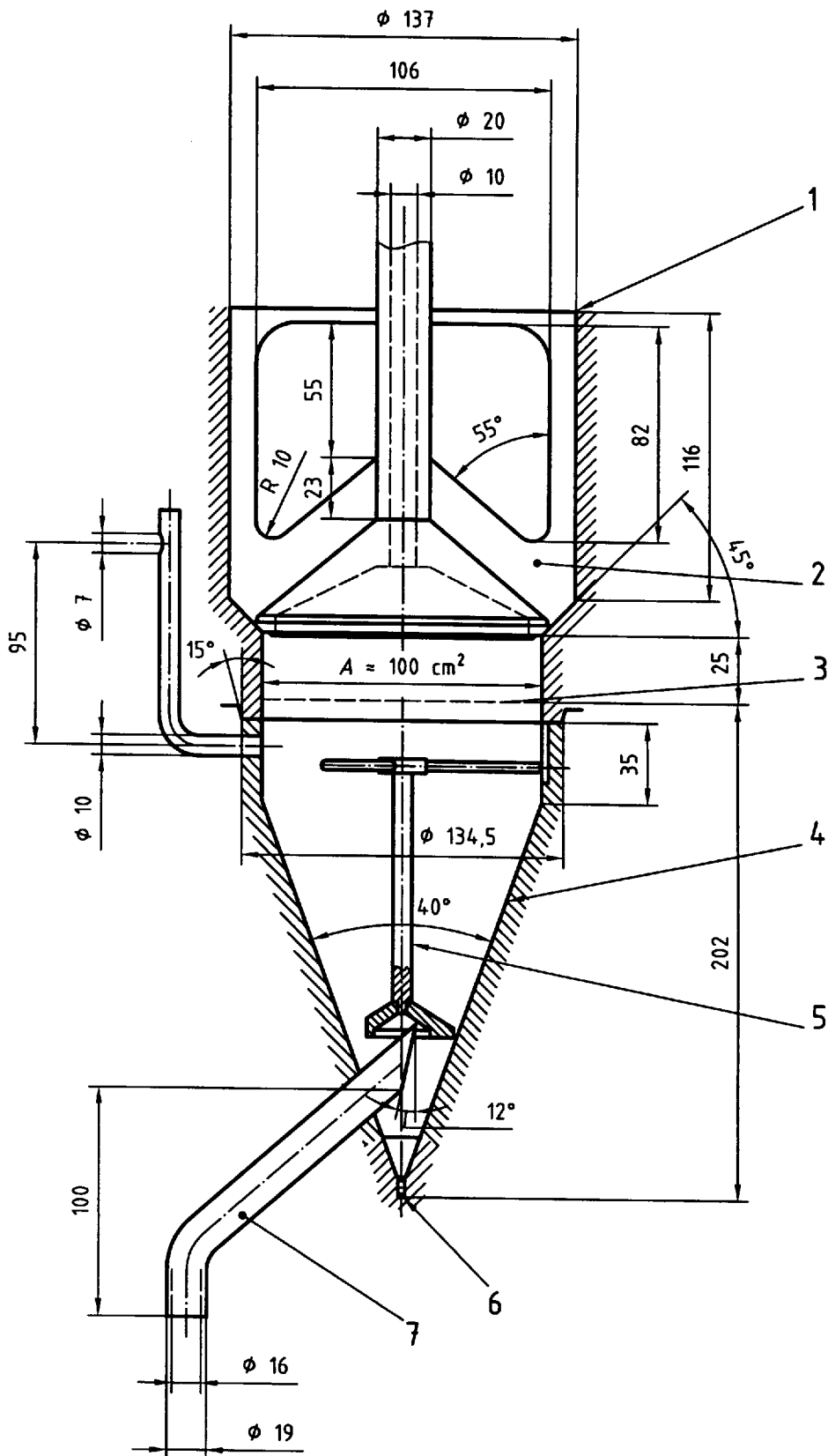

- |                    |               |                  |
|--------------------|---------------|------------------|
| <b>Key</b>         |               |                  |
| 1 Drainage chamber | 3 Wire screen | 5 Spreader cone  |
| 2 Sealing cone     | 4 Funnel      | 6 Bottom orifice |
|                    |               | 7 Side orifice   |

Figure A.1 — Schopper-Riegler apparatus

Dimensions in millimetres

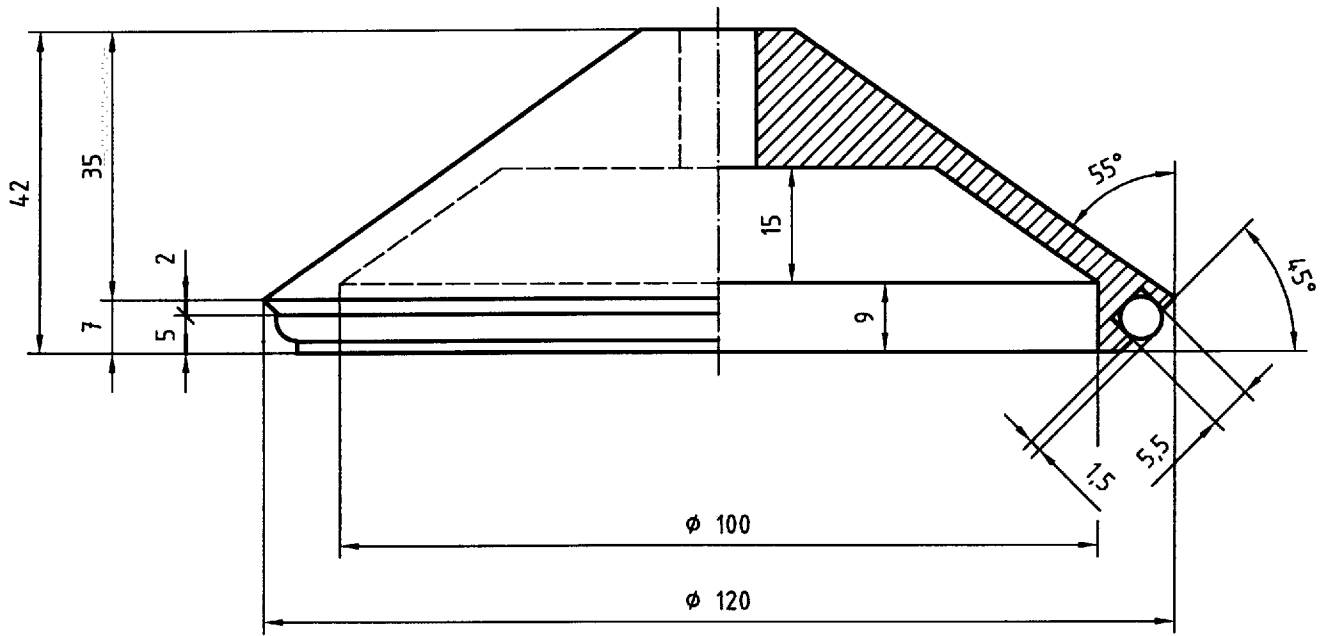

Figure A.2 — Sealing cone

Dimensions in millimetres

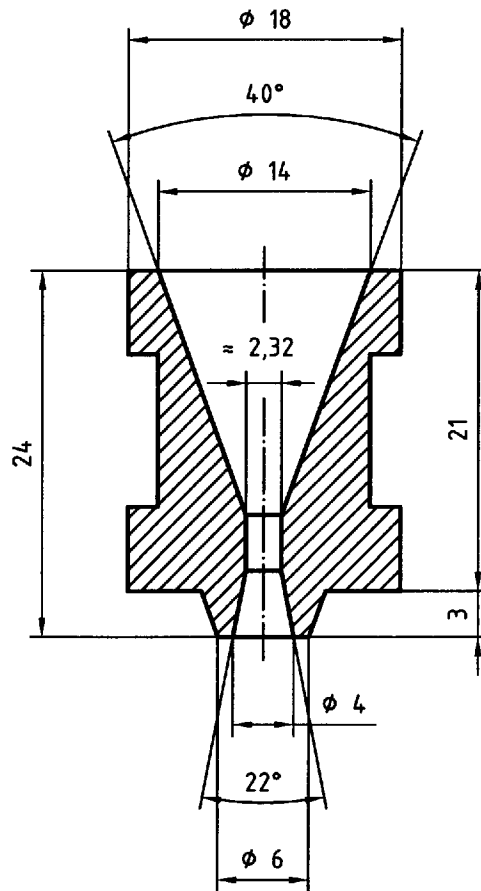

Figure A.3 — Bottom orifice



Dimensions in millimetres

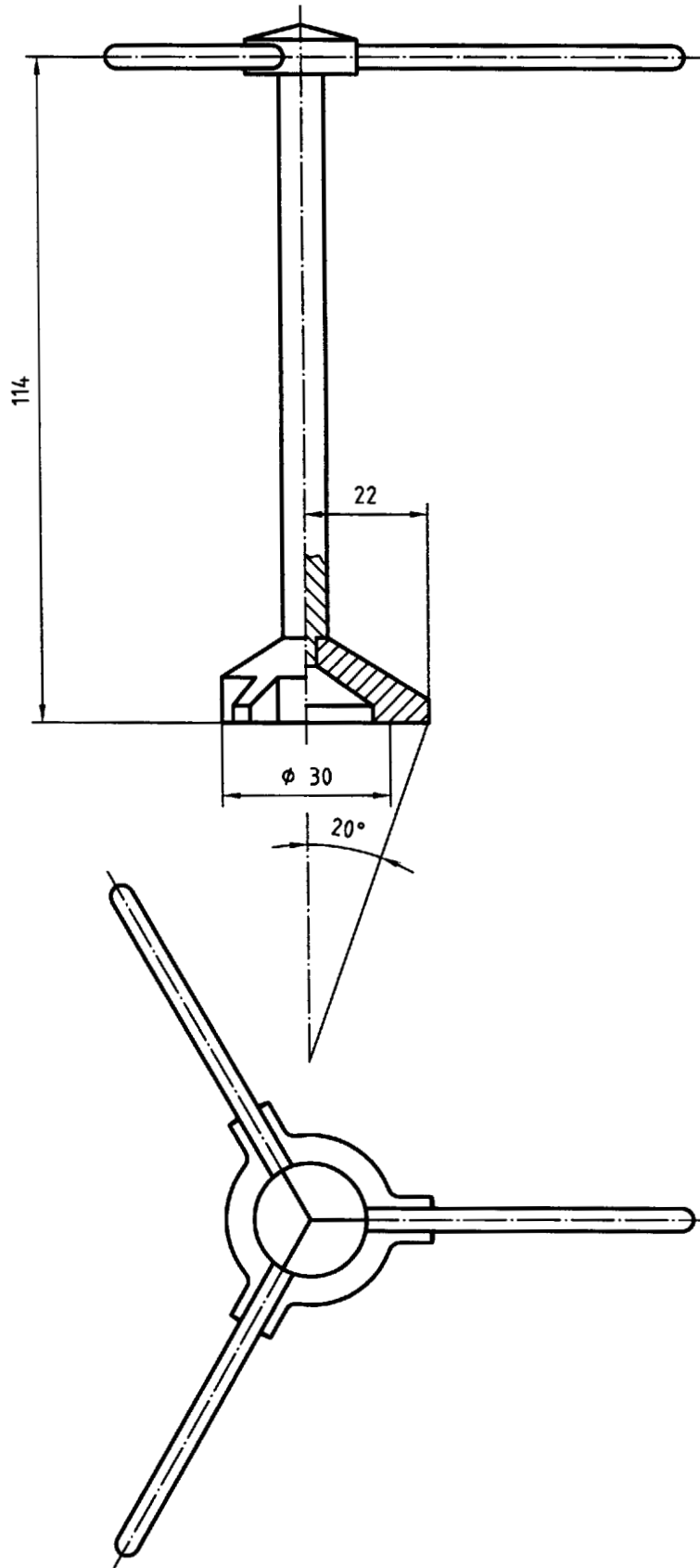

Figure A.4 — Spreader cone

## Annex B (normative)

### Maintenance of the Schopper-Riegler apparatus

**B.1** The Schopper-Riegler apparatus shall be mounted in a vibration-free environment, and carefully levelled by a machinist's level placed on the open top of the rate-measuring funnel, in position in the bracket. Rotation of the level on the funnel will indicate when the instrument is mounted in a true level position.

**B.2** The SR apparatus shall be checked regularly as follows.

**B.2.1** Check with a feeler gauge that the gasket on the wire screen makes a tight fit against the screen, so that the effective drainage area is 100 cm<sup>2</sup>.

**B.2.2** Check that the sealing ring is in good condition. Pour water into the drainage chamber to check that the sealing cone fits tightly.

**B.2.3** Check that the apparatus is clean and free from deposits of pitch. If necessary, clean with soap and rinse thoroughly with water. Special attention should be paid to the wire screen. To check that the wire screen is clean, measure the Schopper-Riegler number for distilled water. A value of more than 4 indicates that the wire screen needs cleaning. If necessary, clean the screen with acetone and a soft brush, and rinse it in abundant water. A wire screen that is not in good condition shall be replaced.

**B.2.4** Check the position of the side orifice as follows. Close the bottom orifice with a finger. Pour 100 ml of water at 20 °C ± 0,5 °C into the funnel. After the excess has escaped through the side orifice, open the bottom orifice, and collect the water leaving the funnel. The volume of the water shall be 7,5 ml to 8,0 ml. If this is not the case, adjust the side orifice. Check that the side orifice is in the right position (see A.4) so that the pressure head is correct.

**B.2.5** Check the dimension of the bottom orifice as follows. Remove the spreader cone. Close the side orifice with a stopper, and fill it by pouring about 500 ml of water at 20 °C into the funnel, while the bottom orifice is closed with a finger. After a moment, allow the excess water to escape through the bottom orifice. When the bottom orifice has been closed again, refill the funnel with 1 000 ml ± 5 ml of water at 20,0 °C ± 0,5 °C, and not the time required for the water to drain through the bottom orifice. The time shall be 149 s ± 1 s.

If the time is too long, the orifice may be widened by honing it with a suitable tool. If the time is too short, the bottom orifice shall be replaced.

**B.2.6** Check that the sealing cone moves at a constant rate of 100 mm/s ± 10 mms/s

---

---

**ICS 85.040**

Price based on 8 pages

---

---