**Resistance spot welding — Electrode
adaptors, male taper 1:10 —**

Part 2:
**Parallel shank fixing for end-thrust
electrodes**

*Équipement de soudage par résistance — Allonges d'électrode à embout
amovible, cône mâle 1:10 —*

Partie 2: Emmanchement cylindrique pour poussée en bout



PDF disclaimer

This PDF file may contain embedded typefaces. In accordance with Adobe's licensing policy, this file may be printed or viewed but shall not be edited unless the typefaces which are embedded are licensed to and installed on the computer performing the editing. In downloading this file, parties accept therein the responsibility of not infringing Adobe's licensing policy. The ISO Central Secretariat accepts no liability in this area.

Adobe is a trademark of Adobe Systems Incorporated.

Details of the software products used to create this PDF file can be found in the General Info relative to the file; the PDF-creation parameters were optimized for printing. Every care has been taken to ensure that the file is suitable for use by ISO member bodies. In the unlikely event that a problem relating to it is found, please inform the Central Secretariat at the address given below.

© ISO 2000

All rights reserved. Unless otherwise specified, no part of this publication may be reproduced or utilized in any form or by any means, electronic or mechanical, including photocopying and microfilm, without permission in writing from either ISO at the address below or ISO's member body in the country of the requester.

ISO copyright office
Case postale 56 • CH-1211 Geneva 20
Tel. + 41 22 749 01 11
Fax + 41 22 749 09 47
E-mail copyright@iso.ch
Web www.iso.ch

Printed in Switzerland

Foreword

ISO (the International Organization for Standardization) is a worldwide federation of national standards bodies (ISO member bodies). The work of preparing International Standards is normally carried out through ISO technical committees. Each member body interested in a subject for which a technical committee has been established has the right to be represented on that committee. International organizations, governmental and non-governmental, in liaison with ISO, also take part in the work. ISO collaborates closely with the International Electrotechnical Commission (IEC) on all matters of electrotechnical standardization.

International Standards are drafted in accordance with the rules given in the ISO/IEC Directives, Part 3.

Draft International Standards adopted by the technical committees are circulated to the member bodies for voting. Publication as an International Standard requires approval by at least 75 % of the member bodies casting a vote.

Attention is drawn to the possibility that some of the elements of this part of ISO 5183 may be the subject of patent rights. ISO shall not be held responsible for identifying any or all such patent rights.

International Standard ISO 5183-2 was prepared by Technical Committee ISO/TC 44, *Welding and allied processes*, Subcommittee SC 6, *Resistance welding*.

This second edition cancels and replaces the first edition (ISO 5183-2:1988), which has been technically revised.

ISO 5183 consists of the following parts, under the general title *Resistance spot welding — Electrode adaptors, male taper 1:10*:

- *Part 1: Conical fixing, taper 1:10*
- *Part 2: Parallel shank fixing for end thrust electrodes*

Resistance spot welding — Electrode adaptors, male taper 1:10 —

Part 2: Parallel shank fixing for end-thrust electrodes

1 Scope

This part of ISO 5183 specifies the dimensions and tolerances of resistance spot welding electrode adaptors where the fixing element for the cap (see ISO 5821) is a male taper of 1:10 and a parallel shaft is used to fix the adaptor to the electrode holder in accordance with ISO 8430-3.

2 Normative references

The following normative documents contain provisions which, through reference in this text, constitute provisions of this part of ISO 5183. For dated references, subsequent amendments to, or revisions of, any of these publications do not apply. However, parties to agreements based on this part of ISO 5183 are encouraged to investigate the possibility of applying the most recent editions of the normative documents indicated below. For undated references, the latest edition of the normative document referred to applies. Members of ISO and IEC maintain registers of currently valid International Standards.

ISO 5182:1991, *Welding — Materials for resistance welding electrodes and ancillary equipment*.

ISO 5821:1979, *Resistance spot welding electrode caps*.

ISO 8430-3: 1988, *Resistance spot welding — Electrode holders — Part 3: Parallel shank fixing for end thrust*.

3 Dimensions

The dimensions shall be those given in Figure 1 and Table 1.

4 Designation

The designation of electrode adaptors which comply with this part of ISO 5183 shall include the following:

- a) the description block (i.e. "spot welding electrode adaptor");
- b) reference to this part of ISO 5183, i.e. ISO 5183-2;
- c) the type of electrode adaptor, in accordance with Figure 1;
- d) the diameter, d_1 , in millimetres;
- e) the length, l_1 , in millimetres;
- f) the material of which the electrode adaptor is made, in accordance with ISO 5182.

ISO 5183-2:2000(E)

EXAMPLE A type C spot welding electrode adaptor, of diameter $d_1 = 16$ mm, length $l_1 = 68$ mm and material type A 2/1, shall be designated as follows:

Spot welding electrode adaptor ISO 5183-2 - C - 16 x 68 - A 2/1

5 Materials

The material of which the electrode adaptor is made shall be in accordance with ISO 5182:1991, preferably group A, type 2.

6 Marking

Electrode adaptors complying with this part of ISO 5183 shall be marked with the designation laid down in clause 4, but excluding the description block and the reference number of this part of ISO 5183, e.g.:

A - 16 x 68 - A 2/1

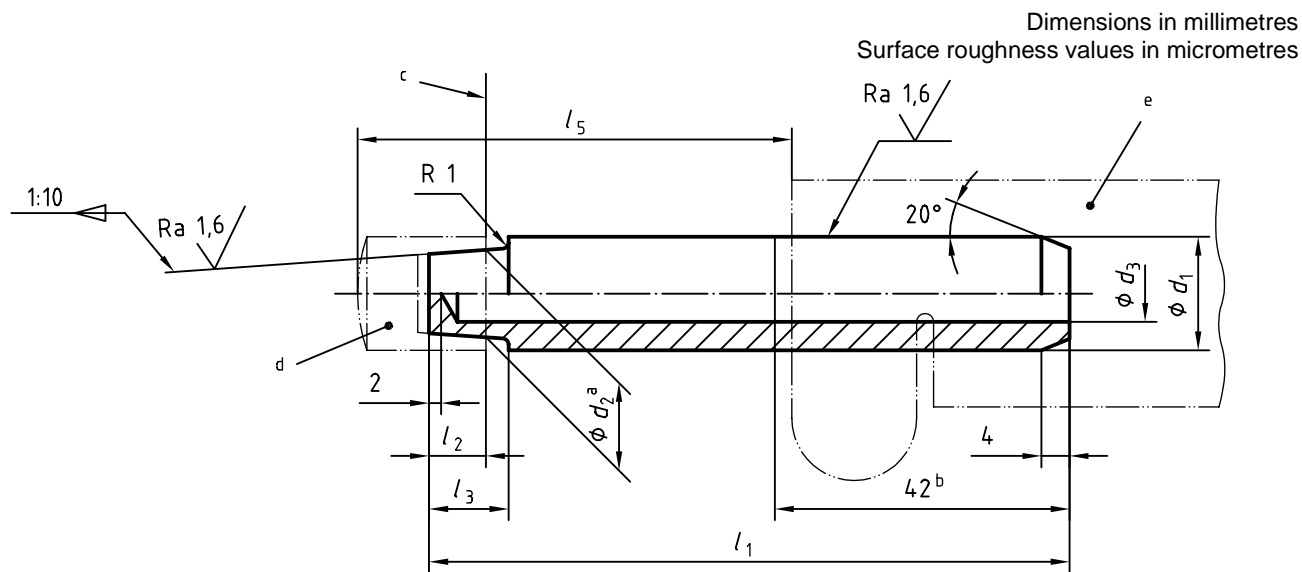

a) Type C: Straight adaptor with cooling hole open on one side

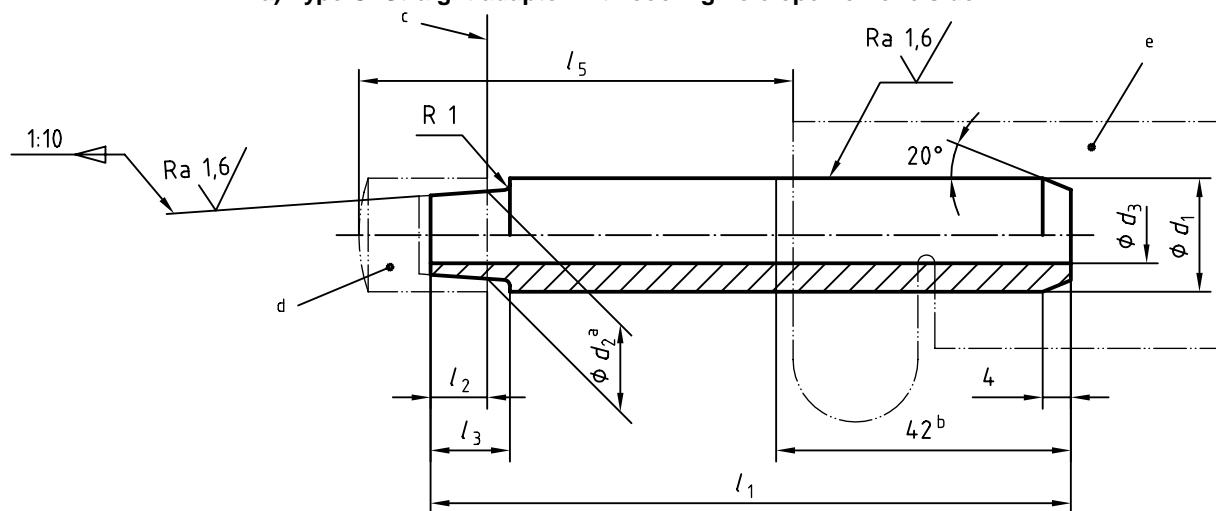

b) Type D: Straight adaptor with cooling hole open on both sides

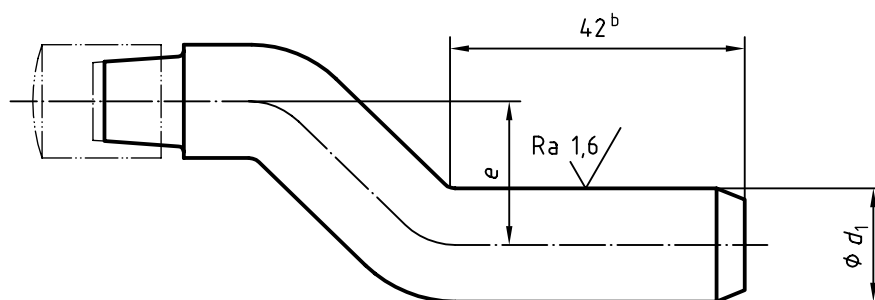
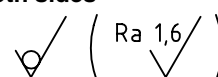

c) Type E: Double cranked adaptor

NOTE Figure c) does not show the cooling hole. However, the adaptor can be provided with cooling hole open on one side, like type C, or open on both sides, like type D.

^a Cone diameter at the gauge plane.

^b Over this length the surface shall be neither damaged nor marked.

^c Gauge plane.

^d Electrode cap, see ISO 5821.

^e Electrode holder, see ISO 8430-3.

Figure 1 — Electrode adaptors

Table 1 — Dimensions for adaptors type C, D and E

Dimensions in millimetres

| d_1 | d_2^a | d_3 | e | l_2 | l_3 | l_1 | | | | | | | | | |
|-------|---------|-------|------|-----------|-------|-------------------|-----------------|-----------------|-------|-------|-------|-------|-----|-------|-----|
| | | | | | | for $l_5^b =$ | | | | | | | | | |
| h11 | | | | $\pm 0,5$ | | 40 | 50 | 63 | 80 | 100 | 125 | (140) | 160 | (180) | 200 |
| 12,5 | 10 | 6,5 | 12,5 | 6,5 | 9 | 68,5 ^c | 78,5 | 91,5 | 108,5 | 128,5 | 153,5 | — | — | — | — |
| 16 | 12 | 8 | 16 | 8 | 11 | 68 ^c | 78 ^c | 91 | 108 | 128 | 153 | 168 | 188 | — | — |
| 20 | 15 | 10,5 | 20 | 10 | 14 | — | 78 ^c | 91 ^c | 108 | 128 | 153 | 168 | 188 | 208 | 228 |

a Cone diameter at the gauge plane.
 b Values given in parentheses are non-preferred.
 c Value that does not apply to type E.

