**Refrigerating systems and heat
pumps — Safety and environmental
requirements —**

Part 1:
**Definitions, classification and
selection criteria**

*Systèmes frigorifiques et pompes à chaleur — Exigences de sécurité et
d'environnement —*

Partie 1: Définitions, classification et critères de choix





COPYRIGHT PROTECTED DOCUMENT

© ISO 2014

All rights reserved. Unless otherwise specified, no part of this publication may be reproduced or utilized otherwise in any form or by any means, electronic or mechanical, including photocopying, or posting on the internet or an intranet, without prior written permission. Permission can be requested from either ISO at the address below or ISO's member body in the country of the requester.

ISO copyright office
Case postale 56 • CH-1211 Geneva 20
Tel. + 41 22 749 01 11
Fax + 41 22 749 09 47
E-mail copyright@iso.org
Web www.iso.org

Published in Switzerland

Contents

	Page
Foreword	iv
Introduction	v
1 Scope	1
2 Normative references	1
3 Terms and definitions	2
3.1 Refrigerating system.....	2
3.2 Location.....	3
3.3 Pressure.....	4
3.4 Components of refrigerating system.....	5
3.5 Piping, joint, and fitting.....	6
3.6 Safety device.....	7
3.7 Fluid.....	9
3.8 Heat transfer circuit.....	10
3.9 Refrigerant disposal.....	10
3.10 Miscellaneous.....	11
4 Abbreviated terms	11
5 Classification	12
5.1 Occupancies classification.....	12
5.2 Systems classification.....	12
5.3 Location classification of refrigerating systems.....	17
5.4 Refrigerant classification.....	18
6 Quantity of refrigerant per occupied space	18
7 Space volume calculations	18
8 Heat-transfer fluid	19
8.1 General.....	19
8.2 Ingestion.....	19
8.3 Water and soil contamination.....	19
8.4 Personal exposure (toxicity).....	19
8.5 Pressure.....	19
8.6 Marking.....	19
8.7 Freezing point.....	19
8.8 Decomposition point.....	20
8.9 Flash point.....	20
8.10 Auto-ignition temperature.....	20
8.11 Thermal expansion.....	20
8.12 Corrosion protection.....	20
Annex A (normative) Location of refrigerating systems	21
Annex B (normative) Safety classification and information about refrigerants	30
Annex C (informative) Potential hazards for refrigerating systems	40
Annex D (informative) Equivalent terms in English and French	42
Bibliography	45

Foreword

ISO (the International Organization for Standardization) is a worldwide federation of national standards bodies (ISO member bodies). The work of preparing International Standards is normally carried out through ISO technical committees. Each member body interested in a subject for which a technical committee has been established has the right to be represented on that committee. International organizations, governmental and non-governmental, in liaison with ISO, also take part in the work. ISO collaborates closely with the International Electrotechnical Commission (IEC) on all matters of electrotechnical standardization.

The procedures used to develop this document and those intended for its further maintenance are described in the ISO/IEC Directives, Part 1. In particular the different approval criteria needed for the different types of ISO documents should be noted. This document was drafted in accordance with the editorial rules of the ISO/IEC Directives, Part 2 (see www.iso.org/directives).

Attention is drawn to the possibility that some of the elements of this document may be the subject of patent rights. ISO shall not be held responsible for identifying any or all such patent rights. Details of any patent rights identified during the development of the document will be in the Introduction and/or on the ISO list of patent declarations received (see www.iso.org/patents).

Any trade name used in this document is information given for the convenience of users and does not constitute an endorsement.

For an explanation on the meaning of ISO specific terms and expressions related to conformity assessment, as well as information about ISO's adherence to the WTO principles in the Technical Barriers to Trade (TBT) see the following URL: Foreword - Supplementary information

The committee responsible for this document is ISO/TC 86, *Refrigeration and air-conditioning*, Subcommittee SC 1, *Safety and environmental requirements for refrigerating systems*.

ISO 5149-1, together with ISO 5149-2, ISO 5149-3, and ISO 5149-4, cancels and replaces ISO 5149:1993, which has been technically revised.

ISO 5149 consists of the following parts, under the general title *Refrigerating systems and heat pumps — Safety and environmental requirements*:

- *Part 1: Definitions, classification and selection criteria*
- *Part 2: Design, construction, testing, marking and documentation*
- *Part 3: Installation site*
- *Part 4: Operation, maintenance, repair and recovery*

Introduction

The purpose of this International Standard is to promote the safe design, construction, disposal, installation, and operation of refrigerating systems.

The industry response to the chlorofluorocarbon (CFC) issue has accelerated the introduction of alternative refrigerants. The entry of new refrigerants and blends in the market and the introduction of new safety classifications prompted the revision of this International Standard.

This International Standard is directed to the safety of persons and property on or near the premises where refrigeration facilities are located. It includes specifications for fabricating a tight system.

This International Standard is intended to minimize possible hazards to persons, property, and environment from refrigerating systems and refrigerants. These hazards are essentially associated with the physical and chemical characteristics of refrigerants as well as the pressures and temperatures occurring in the refrigeration cycles (see [Annex A](#)).

Attention is drawn to hazards common to all compression systems, such as high temperature at discharge, liquid slugging, erroneous operation, or reduction in mechanical strength caused by corrosion, erosion, thermal stress, fatigue stresses, liquid hammer, or vibration.

Corrosion, however, should have special consideration as specific conditions to refrigerating systems arise due to the alternate frosting and defrosting or the covering of equipment by insulation.

Commonly used refrigerants except R-717 are heavier than air. Care should be taken to avoid stagnant pockets of heavy refrigerant vapours by proper location of ventilation inlet and exhaust openings. All machinery rooms are required to have mechanical ventilation controlled by oxygen deficiency alarms or refrigerant vapour alarms.

Refrigerating systems and heat pumps — Safety and environmental requirements —

Part 1: Definitions, classification and selection criteria

1 Scope

This International Standard specifies the requirements for the safety of persons and property, provides guidance for the protection of the environment, and establishes procedures for the operation, maintenance, and repair of refrigerating systems and the recovery of refrigerants.

This part of ISO 5149 specifies the classification and selection criteria applicable to the refrigerating systems and heat pumps. These classification and selection criteria are used in ISO 5149-2, ISO 5149-3, and ISO 5149-4.

This part of ISO 5149 applies to:

- a) refrigerating systems, stationary or mobile, of all sizes including heat pumps;
- b) secondary cooling or heating systems;
- c) the location of the refrigerating systems;
- d) replaced parts and added components after adoption of this part of ISO 5149 if they are not identical in function and in the capacity.

This part of ISO 5149 applies to fixed or mobile systems, except to vehicle air conditioning systems covered by a specific product standard, e.g. ISO 13043 and SAE J 639.

This part of ISO 5149 is applicable to new refrigerating systems, extensions or modifications of already existing systems, and for used systems, being transferred to and operated on another site.

This part of ISO 5149 also applies in the case of the conversion of a system to another refrigerant.

[Annex A](#) specifies the limits for the quantity of refrigerant charge permitted in systems in various locations and occupancy classes.

[Annex B](#) specifies the criteria for safety and environmental considerations of different refrigerants used in refrigeration and air conditioning.

Systems containing refrigerants which are not listed in ISO 817 are not covered in this part of ISO 5149.

2 Normative references

The following documents, in whole or in part, are normatively referenced in this document and are indispensable for its application. For dated references, only the edition cited applies. For undated references, the latest edition of the referenced document (including any amendments) applies.

ISO 817:2014, *Refrigerants — Designation and safety classification*

ISO 5149-2:2014, *Refrigerating systems and heat pumps — Safety and environmental requirements — Part 2: Design, construction, testing, marking and documentation*

3 Terms and definitions

For the purposes of this document, the terms and definitions given in ISO 817 and the following apply.

3.1 Refrigerating system

3.1.1

absorption system

refrigerating system in which refrigeration is effected by evaporation of a refrigerant, the vapour then being absorbed or adsorbed by an absorbent or adsorbent medium, respectively, from which it is subsequently expelled at a higher partial vapour pressure by heating and then liquefied by cooling

3.1.2

cascade system

two or more independent refrigerant circuits where the condenser of one system rejects heat directly to the evaporator of another

3.1.3

direct releasable system

system with one degree of separation from an occupied space

Note 1 to entry: Systems in which the secondary coolant is in contact with the air or the goods to be cooled or heated (e.g. spray systems) are direct releasable systems.

Note 2 to entry: For the purpose of this part of ISO 5149, direct and indirect systems are defined with respect to the potential to leak refrigerant into an occupied space. When the system does not serve an occupied space, it can be classed as direct or indirect depending on the system design.

3.1.4

indirect system

systems with more than one degree of separation from the occupied space

3.1.5

double indirect system

indirect system for which the heat-transfer medium passes through a second heat exchanger located externally to the space, and cools or heats a second heat-transfer medium fluid, which is brought into direct contact with the substance concerned (e.g. by sprays or similar means)

3.1.6

limited charge system

refrigerating system in which the internal volume and total refrigerant charge are such that, with the system idle, the allowable pressure is not exceeded when complete evaporation of the refrigerant occurs

3.1.7

high-pressure side

part of a refrigerating system operating approximately at the condenser pressure

3.1.8

low-pressure side

part of a refrigerating system operating approximately at the evaporator pressure

3.1.9**refrigerating system (heat pump)**

combination of interconnected refrigerant-containing parts constituting one closed circuit in which the refrigerant is circulated for the purpose of extracting and rejecting heat (i.e. cooling and heating)

Note 1 to entry: Refrigerating is used to refer to the on-going process, while refrigeration is used to refer to something that is completed, such as the equipment (refrigeration equipment).

3.1.10**self-contained system**

complete factory-made refrigerating system in a suitable frame and/or enclosure, that is fabricated and transported completely, or in two or more sections and in which no refrigerant-containing parts are connected on site other than by isolation valves, such as companion (block) valves

3.1.11**sealed system**

refrigerating system in which all refrigerant-containing parts are made tight by welding, brazing, or a similar permanent connection

Note 1 to entry: A connection that is tightness-tested for a leakage rate of less than 3 g refrigerant per year under a pressure of at least 0,25 X PS, and where the mechanical joints are prevented from improper use by the need of a special tool (e.g. glue), is considered as a similar permanent connection. This can include capped valves and capped service ports.

3.1.12**system**

set of components working together as a mechanism or interconnected network

Note 1 to entry: Examples of systems are given in 4.2.

3.1.13**unit system**

self-contained system that has been assembled, filled, ready for use, and tested prior to its installation and is installed without the need for connecting any refrigerant-containing parts

3.1.14**split system**

refrigerating system, air conditioner, or heat pump incorporating one or more refrigerant circuits, comprising one or more factory-built indoor units providing cooling or heating to the space and or more factory-built outdoor units

3.1.15**multisplit system**

split system with at least more than one indoor unit

3.2 Location**3.2.1****crawl space**

space that is generally accessed for maintenance only and where it is not possible to walk or access by walking

Note 1 to entry: Usually, the height of crawl spaces is less than 1 m.

3.2.2**exit**

opening in the outer wall, with or without door or gate

3.2.3**exit passageway**

passageway in the immediate vicinity of the door through which people leave the building

3.2.4

hallway

corridor for the passage of people

3.2.5

machinery room

enclosed room or space, with mechanical ventilation, sealed from public areas and not accessible to the public, which is intended to contain components of the refrigerating system

Note 1 to entry: A machinery room can contain other equipment provided that the design and its installation requirements are compatible with the requirements for the safety of the refrigerating system.

3.2.6

occupied space

space in a building which is bounded by walls, floors, and ceilings and which is occupied for a significant period by persons

Note 1 to entry: Where the spaces around the apparent occupied space are, by construction or design, not airtight with respect to the occupied space, these can be considered as part of the occupied space, e.g. false ceiling voids, crawl ways, ducts, movable partitions, and doors with transfer grilles.

3.2.7

open air

any unenclosed space, possibly but not necessarily roofed

3.2.8

special machinery room

machinery room intended to contain only components of the refrigerating system, having no combustion element, (except where the refrigerating system is direct gas fired absorption) and accessible only to competent personnel for the purposes of inspection, maintenance, and repair

3.2.9

ventilated enclosure

enclosure containing the refrigerating system that does not enable air to flow from the enclosure to the surrounding space, and has a ventilation system that produces airflow from the enclosures to the open air through a ventilation duct

3.3 Pressure

3.3.1

design pressure

pressure chosen for the strength calculation of each component

Note 1 to entry: It is used for determining the necessary materials, thickness, and construction for components with regard to their ability to withstand pressure.

3.3.2

tightness test pressure

pressure that is applied to test a system or any part of it for tightness under pressure

3.3.3

maximum allowable pressure

PS

maximum pressure which system or component is designed, as specified by the manufacturer

3.3.4

strength test pressure

pressure that is applied to test the strength of a refrigerating system or any part of it

3.4 Components of refrigerating system

3.4.1

coil

part of the refrigerating system constructed from pipes or tubes suitably connected and serving as a heat exchanger (evaporator or condenser)

Note 1 to entry: A header connecting the tubes of the heat exchanger is part of the coil.

3.4.2

compressor

device for mechanically increasing the pressure of a refrigerant vapour

3.4.2.1

compressor unit

combination of one or more compressors and the regularly furnished accessories

3.4.2.2

positive displacement compressor

compressor in which compression is obtained by changing the internal volume of the compression chamber

3.4.2.3

non-positive displacement compressor

compressor in which compression is obtained without changing the internal volume of the compression chamber

3.4.2.4

open compressor

compressor having a drive shaft penetrating the refrigerant-tight housing

3.4.3

heat exchanger

device designed to transfer heat between two physically separated fluids

3.4.4

condenser

heat exchanger in which refrigerant vapour is liquefied by removal of heat

3.4.5

condensing unit

combination of one or more compressors, condensers or liquid receivers (when required), and the regularly furnished accessories

3.4.6

evaporator

heat exchanger in which liquid refrigerant is vaporized by absorbing heat from the substance to be cooled

3.4.7

pressure vessel

any refrigerant-containing part of a refrigerating system other than

- compressors,
- pumps,
- component parts of sealed absorption systems,
- evaporators, each separate section of which does not exceed 15 l of refrigerant-containing volume,
- coils,

- piping and its valves, joints, and fittings,
- control devices, and
- pressure-containing components (including headers) having an internal diameter or largest cross sectional dimension not greater than 152 mm.

3.4.8

fade-out vessel

vapour receiver connected to the low temperature stage of a limited charge cascade system which is of sufficient size to limit the rise in pressure during system standstill

Note 1 to entry: The receiver provides sufficient volume to accommodate the total refrigerant charge of the circuit as vapour at ambient temperature without exceeding the allowable pressure of the system.

3.4.9

liquid receiver

vessel permanently connected to a system by inlet and outlet pipes for accumulation of liquid refrigerant

3.4.10

internal net volume

volume calculated from the internal dimensions of a vessel, after the subtraction of the volume of the parts within the internal dimensions

3.4.11

refrigerating equipment

components forming a part of the refrigerating system, e.g. compressor, condenser, generator, absorber, adsorber, liquid receiver, evaporator, and surge drum

3.4.12

surge drum

vessel containing refrigerant at low pressure and temperature, and connected by liquid feed and vapour return pipes to an evaporator(s)

3.5 Piping, joint, and fitting

3.5.1

brazed joint

joint obtained by the joining of metal parts with alloys which melt at temperatures that is generally higher than 450 °C, but less than the melting temperatures of the joined parts

3.5.2

companion (block) valve

pair of mating stop valves, isolating sections of systems and arranged so that these sections can be joined before opening these valves or separated after closing them

3.5.3

compression joint

pipe joint in which the tightening of a nut compresses a shaped ring that presses on the outside of the pipe sealing the system

3.5.4

flanged joint

joint made by bolting together a pair of flanged ends

3.5.5

flared joint

metal-metal compression joint in which a conical spread is made on the end of the tube

3.5.6**header**

pipe or tube component of a refrigerating system to which several other pipes or tubes are connected

3.5.7**isolating valve**

valve which prevent flow in either direction when closed

3.5.8**joint**

connection which assures the gas-tight connection between parts

3.5.9**pipng**

pipes or tubes (including any hose, bellows, or flexible pipe) for interconnecting the various parts of a refrigerating system

3.5.10**quick-closing valve**

shut-off device which closes automatically (e.g. by weight, spring force, quick closing ball) or has a closing angle of 130° or less

3.5.11**service duct**

duct containing the electrical supply, refrigerant piping, plumbing, other ducts, or equivalent service required for operation of the product

3.5.12**shut-off device**

device to shut off the flow of the fluid

3.5.13**tapered thread joint**

threaded pipe joint requiring filler materials in order to block the spiral leakage path

3.5.14**three-way valve**

service valve that connects one refrigerant line to one or two other refrigerant lines and generally intended to permit servicing part of a refrigerating system without removing the refrigerant from the complete system

3.5.15**welded joint**

assembly of metal parts in the plastic or molten state

3.6 Safety device**3.6.1****bursting disc**

disc or foil which bursts at a predetermined differential pressure

Note 1 to entry: Bursting disc is also called rupture disc or rupture member.

3.6.2**changeover device**

valve controlling two safety devices and so arranged that only one can be made inoperative at any one time

3.6.3**fusible plug**

device containing any material which melts at a predetermined temperature and relieves the pressure

3.6.4

liquid level cut out

actuated device designed to prevent unsafe liquid levels

3.6.5

overflow valve

pressure relief device discharging to the low pressure side of the refrigerating system

3.6.6

pressure limiter

switching device for limiting the pressure that resets automatically

3.6.7

pressure relief device

pressure relief valve or bursting disc device designed to relieve excessive pressure automatically

3.6.8

pressure relief valve

pressure-actuated valve held shut by a spring or other means and designed to relieve excessive pressure automatically

3.6.9

refrigerant detector

sensing device which responds to a pre-set concentration of refrigerant in the environment

3.6.10

safety switching device for limiting the pressure

type-approved pressure-actuated device that is designed to stop the operation of the pressure generator

3.6.11

self-closing valve

valve that closes automatically, e.g. by weight or spring force

3.6.12

temperature limiting device

temperature-actuated device that is designed to prevent excessive temperatures

Note 1 to entry: A fusible plug is not a temperature limiting device.

3.6.13

type-approved component

component for which the examination is performed on one or more samples of this component by following a recognized standard for type approval

3.6.13.1

type-approved pressure cut out

safety switching device for limiting the pressure that requires to be manually reset

3.6.13.2

type-approved pressure limiter

safety switching device for limiting the pressure that automatically resets

3.6.13.3

type-approved safety pressure cut out

safety switching device for limiting the pressure that requires to be reset manually only with the aid of a tool

3.7 Fluid

3.7.1

lubricant

fluid present in the internal volume of the refrigerating system, present for the main purpose of lubrication of wearing surfaces

3.7.2

azeotrope

blend composed of two or more refrigerants whose equilibrium vapour and liquid phase compositions are the same at a given pressure, but can be different at other condition

Note 1 to entry: See [Table B.3](#).

[SOURCE: ISO 817:2014, 2.5 — Note 1 to entry has been added.]

3.7.3

zeotrope

blend composed of two or more refrigerants whose equilibrium vapour and liquid phase compositions are not the same at any pressure below the critical pressure

[SOURCE: ISO 817:2014, 2.1.44]

Note 1 to entry: See [Table B.2](#).

3.7.4

halocarbon

chemical compound consisting of halogen (fluorine, chlorine, bromine, or iodine), carbon, and in some cases, hydrogen

3.7.5

hydrocarbon

chemical compound consisting of hydrogen and carbon

3.7.6

heat-transfer fluid

HTF

fluid (e.g. brine, water, air) for the transmission of heat

3.7.7

auto-ignition temperature

lowest temperature of a substance at or above which a chemical can spontaneously ignite in a normal atmosphere, without an external source of ignition, such as a flame or spark

3.7.8

outside air

air from outside of the building

3.7.9

refrigerant

fluid used for heat transfer in a refrigerating system, which absorbs heat at a low temperature and a low pressure of the fluid, and rejects it at a higher temperature and a higher pressure of the fluid usually involving changes of the phase of the fluid

Note 1 to entry: Refrigerants are listed in ISO 817.

[SOURCE: ISO 817:2014, 2.32 — Note 1 to entry has been added.]

3.7.10

refrigerant type

chemical compound or blend of compounds used as a specific nomenclature designation

Note 1 to entry: Designation is given in ISO 817.

3.7.11

toxicity

ability of a refrigerant or a heat-transfer fluid to be harmful or lethal or to impair a person's ability to escape due to acute or chronic exposure by contact, inhalation, or ingestion

Note 1 to entry: Temporary discomfort that does not impair health is not considered to be harmful.

3.7.12

flammability

ability of a refrigerant or heat-transfer fluid to propagate a flame from an ignition source

3.7.13

practical limit

concentration used for simplified calculation to determine the maximum acceptable amount of refrigerant in an occupied space

Note 1 to entry: Refrigerant Concentration Limit (RCL) is determined by toxicity or flammability tests, but practical limit is derived from RCL or historically established charge limit.

3.8 Heat transfer circuit

3.8.1

heat-transfer circuit

circuit which is composed of at least two heat exchangers and interconnecting pipes

3.9 Refrigerant disposal

3.9.1

disposal

to dispose of or to convey a product usually for scrapping or destruction

3.9.2

reclaim

to process used refrigerants to new product specifications

3.9.3

recover

to remove refrigerant in any condition from a system and store it in an external container

3.9.4

recycle

reduction of contaminants in used refrigerants by separating oil, removing non-condensables, and using devices to reduce moisture, acidity, and particulate matter

Note 1 to entry: Devices can include filters and dryers.

3.9.5

reuse

use (charge) of recovered refrigerant without any processing to remove impurities

3.10 Miscellaneous

3.10.1

factory made

manufactured at a dedicated production location under control of a recognized quality system

3.10.2

dilution transfer opening

opening which allows the leaked refrigerant to flow out from the room to an adjacent room or corridor by density difference, dilution, convection, or ventilation

3.10.3

quantity limit with additional ventilation

charge of refrigerant that results in a concentration equal to the Oxygen Deprivation Limit (ODL), if the total charge leaked with the occupied space

Note 1 to entry: See [A.5](#) for the use of Quantity Limit with Additional Ventilation (QLAV) to manage risk for systems in occupied spaces where the level of ventilation is sufficient to disperse the leaked refrigerant within 15 min.

3.10.4

quantity limit with minimum ventilation

charge of refrigerant that results in a concentration equal to the RCL in a room of non-airtight construction with a moderately severe refrigerant leak

Note 1 to entry: See [A.5](#) for the use of QLAV to manage risk for systems in occupied spaces not below ground level where the level of ventilation is not sufficient to disperse the leaked refrigerant within 15 min. The calculation is based on an opening of 0,003 2 m² and a leak rate of 2,78 g/s.

4 Abbreviated terms

A/C	Air Conditioning systems
ATEL	Acute Toxicity Exposure Limit
GWP	Global Warning Potential
HTF	Heat-Transfer Fluid
ITH	Integration Time Horizon
LFL	Lower Flammability Limit
MSDS	Material Safety Data Sheet
ODL	Oxygen Deprivation Limit
ODP	Oxygen Deprivation Potential
PS	Maximum Allowable Pressure
QLAV	Quantity Limit with Additional Ventilation
QLMV	Quantity Limit with Minimum Ventilation
RCL	Refrigerant Concentration Limit

5 Classification

5.1 Occupancies classification

For the purpose of this International Standard, occupancy classification shall be determined according to [Table 1](#).

Machinery rooms shall not be considered as an occupied space except as defined in ISO 5149-3:2014, 5.1.

Table 1 — Categories of occupancy

Categories	General characteristics	Examples ^a
General occupancy a	Rooms, parts of buildings, building where — sleeping facilities are provided, — people are restricted in their movement, — an uncontrolled number of people are present, or — to which any person has access without being personally acquainted with the necessary safety precautions.	Hospitals, courts or prisons, theatres, supermarkets, schools, lecture halls, public transport termini, hotels, dwellings, and restaurants
Supervised occupancy b	Rooms, parts of buildings, buildings where only a limited number of people can be assembled, some being necessarily acquainted with the general safety precautions of the establishment.	Business or professional offices, laboratories, places for general manufacturing, and where people work
Authorized occupancy c	Rooms, parts of buildings, buildings where only authorized persons have access, who are acquainted with general and special safety precautions of the establishment and where manufacturing, processing, or storage of material or products take place.	Manufacturing facilities, e.g. for chemicals, food, beverage, ice, ice-cream, refineries, cold stores, dairies, abattoirs, and non-public areas in supermarkets
^a The list of examples is not exhaustive.		

NOTE Occupancies can be classified by national requirements.

5.2 Systems classification

5.2.1 General

Refrigerating systems are classified according to

- the method of extracting heat from the atmosphere (cooling),
- the method of adding heat to the atmosphere (heating),
- the substance to be treated, or
- the refrigerant leak entering the occupied space.

5.2.2 Direct releasable system

5.2.2.1 Direct systems

A direct system shall be classed as a direct releasable system if a single rupture of the refrigerant circuit results in a refrigerant release to an occupied space, irrespective of the location of the refrigerant circuit (see [Figure 1](#)).

Direct systems are considered to be located in location classification I (see [5.3.5](#)) or II (see [5.3.4](#)).

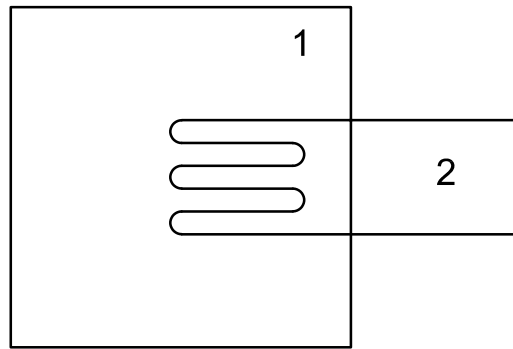
**Key**

- 1 occupied space
- 2 refrigerant-containing part(s)

Figure 1 — Direct system**5.2.2.2 Open spray system**

An open spray system shall be classed as a direct releasable system if the heat-transfer medium is in direct communication with the refrigerant-containing parts of the circuit and the indirect circuit is open to an occupied space (see [Figure 2](#)).

Open spray systems are considered to be located in location classification I (see [5.3.5](#)) or II (see [5.3.4](#)).

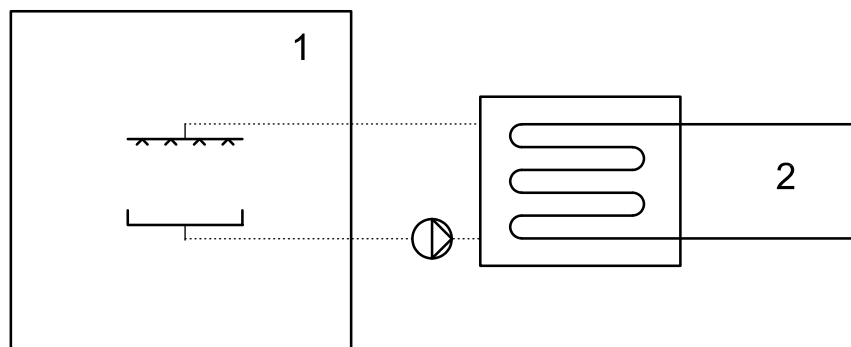
**Key**

- 1 occupied space
- 2 refrigerant- containing part(s)
- ... heat-transfer medium

Figure 2 — Open spray system**5.2.2.3 Direct ducted system**

A direct ducted system shall be classed as a direct releasable system if the conditioned air is in direct communication with the refrigerant-containing parts of the circuit and is supplied to an occupied space (see [Figure 3](#)).

Direct ducted systems are considered to be located in location classification I (see [5.3.5](#)) or II (see [5.3.4](#)).

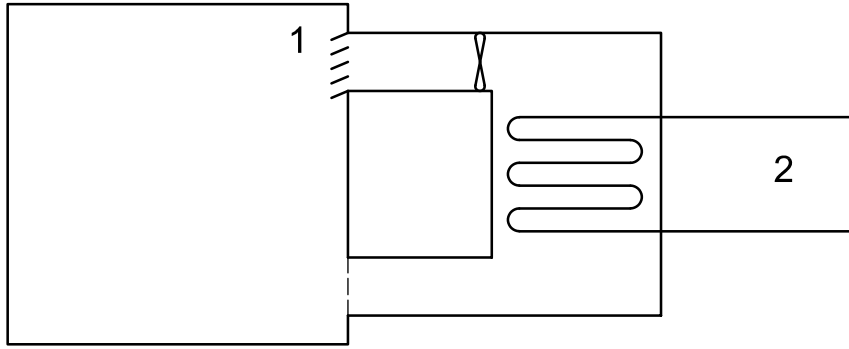

Key

- 1 occupied space
- 2 refrigerant-containing part(s)

Figure 3 — Direct ducted system

5.2.2.4 Open vented spray system

An open vented spray system shall be classed as a direct releasable system if the heat-transfer medium is in direct contact with refrigerant-containing parts of the circuit and the indirect circuit is open to an occupied space (see [Figure 4](#)). The heat-transfer medium shall be vented to the atmosphere outside the occupied space, but the possibility remains that a single rupture of the refrigerant circuit could result in a refrigerant release to the occupied space.

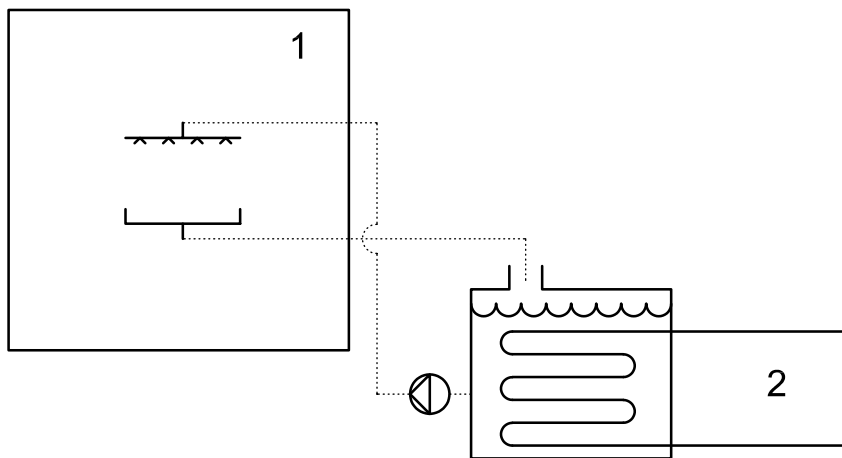

Key

- 1 occupied space
- 2 refrigerant-containing part(s)
- ... heat-transfer medium

Figure 4 — Open vented spray system

5.2.3 Indirect systems

5.2.3.1 Indirect closed system

An indirect system shall be classed as indirect closed system if the heat-transfer medium is in direct communication with an occupied space, and a refrigerant leak into the indirect circuit can enter the occupied space if the indirect circuit also leaks or purged (see [Figure 5](#)).

Indirect closed systems are considered to be located in location classification I (see 5.3.5) or II (see 5.3.4).

NOTE A pressure relief device (or purger) on a secondary circuit is an appropriate method to prevent the refrigerant leaking into the occupied space. Such a system is not considered as an indirect closed system (see 5.2.3.3).

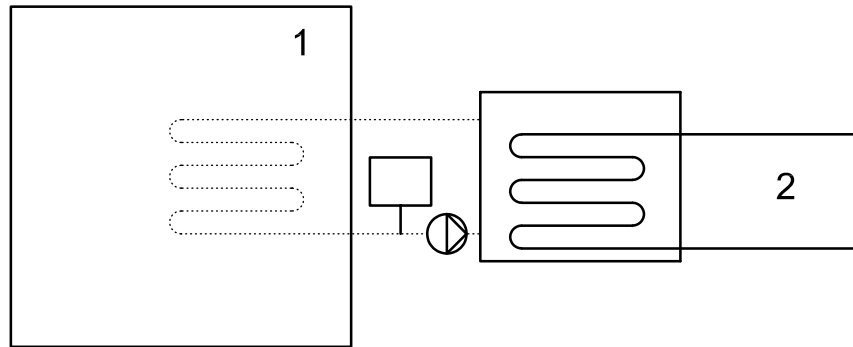

Key

- 1 occupied space
- 2 refrigerant-containing part(s)
- ... heat-transfer medium

Figure 5 — Indirect closed system

5.2.3.2 Indirect vented system

An indirect system shall be classed as indirect vented system if the heat-transfer medium is in direct communication with an occupied space, and a refrigerant leak into the indirect circuit can vent to atmosphere outside the occupied space (see Figure 6).

NOTE This can be achieved by using a double-walled heat exchanger.

Indirect vented systems are considered to be located in location classification III (see 5.3.3).

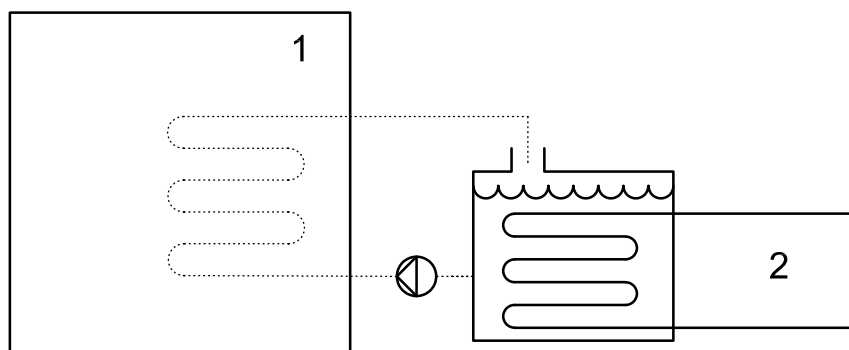

Key

- 1 occupied space
- 2 refrigerant-containing part(s)
- ... heat-transfer medium

Figure 6 — Indirect vented system

5.2.3.3 Indirect vented closed system

An indirect system shall be classed as an indirect vented closed system if the heat-transfer medium is in direct communication with an occupied space and a refrigerant leak into the indirect circuit can vent to atmosphere, through a mechanical vent, outside the occupied space (see [Figure 7](#)).

Indirect vented closed systems are considered to be located in location classification III (see [5.3.3](#)).

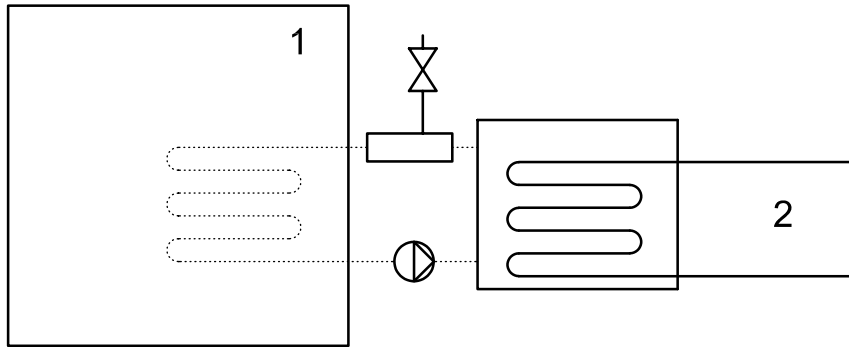

- Key**
- 1 occupied space
 - 2 refrigerant-containing part(s)
 - ... heat-transfer medium

Figure 7 — Indirect vented closed system

5.2.3.4 Double indirect system

An indirect system shall be classed as a double indirect system if the heat-transfer medium is in contact with refrigerant-containing parts, and the heat be exchanged with a second indirect circuit that passes into an occupied space (see [Figure 8](#)). A refrigerant leak cannot enter the occupied space.

Double indirect vented systems are considered to be located in location classification III (see [5.3.3](#)).

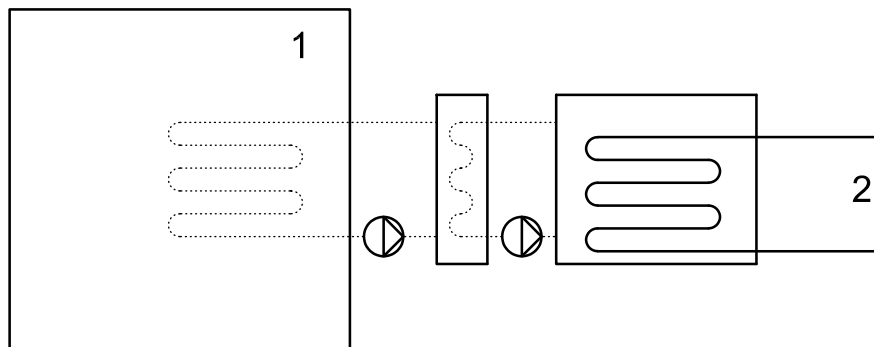

- Key**
- 1 occupied space
 - 2 refrigerant-containing part(s)
 - ... heat-transfer medium

Figure 8 — Double indirect system

5.2.3.5 High-pressure indirect system

An indirect system shall be classed as a high-pressure indirect system if the heat-transfer medium is in direct communication with an occupied space and the indirect circuit is maintained at a higher pressure than the refrigerant circuit at all times, so that a rupture of the refrigerant circuit cannot result in a refrigerant release to the occupied spaces (see [Figure 9](#)).

High-pressure indirect systems are considered to be located in location classification III (see [5.3.3](#)).

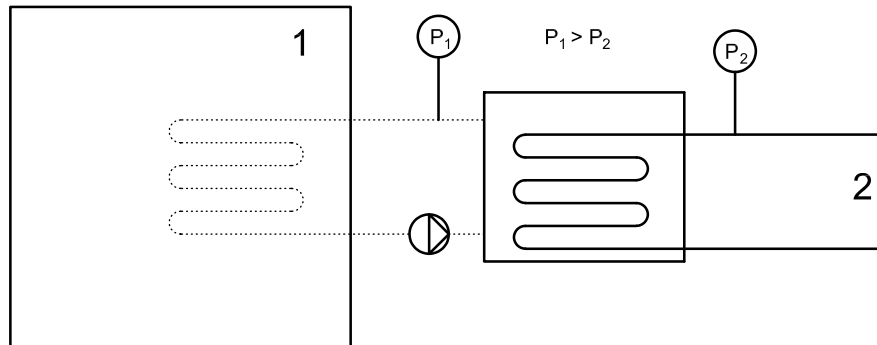

Key

- 1 occupied space
- 2 refrigerant-containing part(s)
- P1 pressure 1
- P2 pressure 2
- ... heat-transfer medium

Figure 9 — High-pressure indirect system

5.3 Location classification of refrigerating systems

5.3.1 General

Charge limit requirements for refrigerating systems shall be calculated in accordance with the location class, as specified in [5.3.2](#) to [5.3.5](#), and the toxicity and/or the flammability of the refrigerant as specified in [Annex A](#).

5.3.2 Class IV: ventilated enclosures

If all refrigerant-containing parts are located in the ventilated enclosures, then the requirements for a class IV location shall apply. The ventilated enclosures shall fulfil the requirements of ISO 5149-2 and ISO 5149-3.

5.3.3 Class III: machinery room or open air

If all refrigerant-containing parts are located in a machinery room or open air, then the requirements for a class III location shall apply. The machinery room shall fulfil the requirements of ISO 5149-3.

EXAMPLE Water-cooled chiller.

5.3.4 Class II: compressors in machinery room or open air

If all compressors and pressure vessels are either located in a machinery room or in the open air, then the requirements for a class II location shall apply unless the system complies with the requirements of [5.3.3](#). Coil-type heat exchangers and pipework, including valves, can be located in an occupied space.

EXAMPLE Cold store.

5.3.5 Class I: mechanical equipment located within the occupied space

If the refrigerating system or refrigerant-containing parts are located in the occupied space, then the system is considered to be of class I unless the system complies with the requirements of [5.3.4](#).

5.4 Refrigerant classification

The refrigerant classification according to ISO 817:2014 shall be applied.

6 Quantity of refrigerant per occupied space

6.1 The amount of a refrigerant charge that could enter into the occupied space shall be determined as follows.

- For occupied spaces, the refrigerant quantity shall not exceed the amounts specified in [Tables A.1](#) and [A.2](#).
- The refrigerant quantity is the quantity that can be released in an occupied space, and shall be the largest charge of any single refrigerating system, unless otherwise specified in this International Standard.

6.2 Where IEC or ISO product standards exist for particular types of systems and where these product standards refer to refrigerant quantities limits, such quantities shall overrule the requirements of this part of ISO 5149.

7 Space volume calculations

7.1 The space considered shall be any occupied space which contains refrigerant-containing parts.

7.2 The volume (V) of the smallest, enclosed, occupied space shall be used in the determination of the refrigerant quantity limits.

7.3 Multiple spaces that have appropriate openings (that cannot be closed) between the individual spaces or are connected with a common ventilation supply, return, or exhaust system not containing the evaporator or the condenser shall be treated as a single space. Where the evaporator or condenser is located in an air supply duct system serving multiple spaces, the volume of the smallest single space shall be used. If the air flow to a space cannot be reduced to less than 10 % of the maximum air flow by the use of an air flow reducer, then that space shall be included in the volume of the smallest occupied space.

7.4 Where the evaporator or condenser is located in an air supply duct system and the system serves an unpartitioned multi-storey building, the occupied volume of the smallest occupied storey of the building shall be used.

7.5 The space above a false ceiling or partition shall be included in the volume calculation unless the false ceiling is airtight.

7.6 Where an indoor unit of a system, or any refrigerant-containing pipe working thereof, is located in a volume of such size so that the total charge exceeds the allowable charge, special provisions shall be made to ensure at least an equivalent level of safety. See [A.5](#).

8 Heat-transfer fluid

8.1 General

Where fluids listed in [Annex B](#) are used as heat-transfer fluids, the circuit shall be treated as a refrigerating circuit and the fluid as a refrigerant. The designer shall take into account the criteria described in [8.2](#) to [8.12](#) when selecting a heat-transfer fluid.

8.2 Ingestion

The use of heat-transfer fluids for the cooling or heating of food products shall comply with national or regional regulations.

NOTE Many food processing applications rely on a heat-transfer fluid for indirect cooling or freezing. Use of a “food grade” heat-transfer coolant mitigates the risk of injuring persons by an unintentional leakage into the food product.

The effects of a leak when the fluid is under pressure shall be considered.

8.3 Water and soil contamination

Where the heat-transfer fluid is not listed in this part of ISO 5149 or national regulations for human consumption or release to ground water, provision for containment shall be made in the design of the system and the building in the event of a leak.

8.4 Personal exposure (toxicity)

The risk of personal exposures to heat-transfer fluid shall be determined by reviewing the Material Safety Data Sheet (MSDS).

8.5 Pressure

The heat-transfer fluid containment circuit shall be capable of withstanding the pressures generated in the heat-transfer circuit in accordance with ISO 5149-2.

8.6 Marking

The system shall be marked with a design pressure rating in accordance with ISO 5149-2.

8.7 Freezing point

If the freezing point of the heat-transfer fluid is more than 3 K below the lowest temperature of the primary circuit refrigerant, no additional requirements shall apply. A freezing point greater than the lowest temperature of the primary circuit refrigerant is permitted if the pressure of the secondary circuit does not exceed the design pressure rating of the pressure-containing parts. The pressure shall be determined under a freezing blockage at the most adverse point in the circuit. The freezing point of the HTF is also permitted to be greater than the lowest temperature of the primary circuit refrigerant if the circuit contains an automatic control that stops the primary circuit refrigeration function before the secondary circuit is blocked. Fluids that expand on freezing shall not cause the pressure in the secondary circuit to exceed the rated pressure for the circuit and shall not cause permanent deformation of the pipe under freezing conditions. Compliance shall be checked by testing at 10 K below the freezing point of the fluid or at the temperatures that can be reached under blocked conditions, whichever is lower.

8.8 Decomposition point

To avoid decomposition of the heat-transfer fluid, the maximum operating temperature shall not be greater than the maximum rated operating temperature of the fluid as specified by the manufacturer.

8.9 Flash point

The flash point of the fluid shall not be less than 55 °C as specified in the MSDS.

8.10 Auto-ignition temperature

If the HTF is flammable, its auto-ignition temperature shall be greater than 100 °C.

8.11 Thermal expansion

Equipment shall be protected against thermal expansion.

NOTE Most liquids expand as temperature rises, but some liquids expand when temperature is lowered.

8.12 Corrosion protection

The HTF shall include adequate corrosion inhibitors for all system materials.

NOTE Most non-aqueous-based heat-transfer fluids are inherently non-corrosive provided they are not contaminated by water.

Annex A (normative)

Location of refrigerating systems

A.1 General

There are four types of location for refrigerating systems: class I, class II, class III, and class IV (see [Tables A.1](#) and [A.2](#)). The appropriate location shall be selected in accordance with [5.3](#).

NOTE Some heat pumps/air conditioners operate for either heating or cooling by reversing the flow from the compressor to the heat exchangers by means of a special reversing valve. In these cases, the high and low pressure sides of the system can change depending on the mode of the unit.

Refrigerating systems or parts of systems shall not be installed in or on stairways, landings, entrances, or exits used by the public, if free passage is thereby limited.

[Tables A.1](#) and [A.2](#) show the refrigerant charge limit and the specific requirements for reference system for different locations and applications based on the specific toxicity and flammability characteristics of the refrigerant used. The charge limit can be an absolute value or calculated from characteristic refrigerant data and room volumes.

If a secondary system serving an occupied space employs a substance that is listed as a refrigerant in [Annex B](#), the charge of that heat-transfer fluid shall be calculated by using the requirements for direct releasable systems within [Tables A.1](#) and [A.2](#).

A.2 Charge limit requirements for refrigerating systems

Refrigerant charge limits shall be calculated according to [Tables A.1](#) and [A.2](#), depending on the toxicity and/or the flammability of the refrigerant.

The following method shall be applied to determine the charge limit of a refrigerating system.

- 1) Define which occupancy category (a, b, or c, according to [5.1](#)) applies and which location class (I, II, III, or IV, according to [5.3](#)) the system is used in.
- 2) Define the toxicity class of the refrigerant (A or B, according to [Tables B.1](#) and [B.2](#)) used in the refrigerating system. The toxicity limit equals ATEL/ODL values or practical limits whichever is higher. Where dual classification exists, the more restrictive classification is used.
- 3) Determine the charge limit for the refrigerating system based on [Table A.1](#).
- 4) Define the flammability class of the refrigerant (1, 2L, 2, 3, etc., according to [Tables B.1](#) and [B.2](#)) used in the refrigerating system and the corresponding LFL. Where dual classification exists, the more restrictive classification is used.
- 5) Determine the charge limit for the refrigerating system based on [Table A.2](#).
- 6) The lowest refrigerant charge obtained according to 3) and 5) is applied. For determination of charge limits for refrigerants of flammability class 1, 5) can be omitted.

The charge limits in [Table A.2](#) are capped to a limit based upon the LFL of the refrigerant. In the case of flammability class 2 or 3 refrigerants, the basic cap factor is m_1 , m_2 , and m_3 . For flammability class 2L refrigerants, the basic cap factor is increased by a factor of 1,5 in recognition of the lower burning velocity of these refrigerants, which lead to a reduced risk of ignition and impact. The cap factor used in

[Table A.2](#) can be increased where occupants are familiar with the safety requirements for the building (for example, occupancy class b or c), or where risk of leakage is reduced.

The cap factors given in [Table A.2](#) shall be calculated as follows:

$$m_1 = 4 \text{ m}^3 \times \text{LFL} \quad (\text{A.1})$$

$$m_2 = 26 \text{ m}^3 \times \text{LFL} \quad (\text{A.2})$$

$$m_3 = 130 \text{ m}^3 \times \text{LFL} \quad (\text{A.3})$$

where LFL equals the lower flammable limit in kg/m³ according to [Annex B](#).

NOTE The cap factor of 26 is based on a charge of 1 kg of R-290.

For refrigerants of flammability class 2L, there are no room volume restrictions for refrigerant charges below or equal to $m_1 \times 1,5$. For refrigerants of flammability classes 2 and 3, there are no room volume restrictions for refrigerant charges below or equal to m_1 .

Table A.1 — Charge limit requirements for refrigerating systems based on toxicity

Toxicity class	Occupancy category	Location classification			
		I	II	III	IV
A	a	Upper floors without emergency exits or below ground floor level	Toxicity limit × Room volume or see A.5	No charge restriction ^a	No charge restriction ^a
		Other	No charge restriction ^a		
		b	Upper floors without emergency exits or below ground floor level		
	Other		No charge restriction ^a		
	c		Upper floors without emergency exits or below ground floor level		
		Other	No charge restriction ^a		
B		a	For sealed absorption systems, Toxicity limit × Room volume and not more than 2,5 kg, all other systems, Toxicity limit × Room volume	No charge restriction ^a	The charge requirements shall be assessed according to location classification I, II, or III, depending on the location of the ventilated enclosure.
	b		Upper floors without emergency exits or below ground floor level	Toxicity limit × Room volume	
			Density of personnel <1 person per 10 m ²	Charge not more than 10 kg ^a	
		Other	Charge not more than 10 kg ^a		
	c	Density of personnel <1 person per 10 m ²	Charge not more than 50 kg ^a and emergency exits are available	No charge restriction ^a	
		Other	Charge not more than 10 kg ^a	Charge not more than 25 kg ^a	
Other		Charge not more than 10 kg ^a	Charge not more than 25 kg ^a		

^a ISO 5149-3:2014, 5.2 and 8.1 applies.

Table A.2 — Charge limit requirements for refrigerating systems based on flammability

Flammability class	Occupancy category	Location classification			
		I	II	III	IV
2L	a	Human comfort	According to A.4 and not more than $m_2^a \times 1,5$ or according to A.5 and not more than $m_3^b \times 1,5$	No charge restriction ^c	Refrigerant charge not more than $m_3^b \times 1,5$
		Other applications	$20\% \times \text{LFL} \times \text{Room volume}$ and not more than $m_2^a \times 1,5$ or according to A.5 and not more than $m_3^b \times 1,5$		
	Human comfort	According to A.4 and not more than $m_2^a \times 1,5$ or according to A.5 and not more than $m_3^b \times 1,5$			
	Other applications	$20\% \times \text{LFL} \times \text{Room volume}$ and not more than $m_2^a \times 1,5$ or according to A.5 and not more than $m_3^b \times 1,5$	$20\% \times \text{LFL} \times \text{Room volume}$ and not more than 25 kg^c or according to A.5 and not more than $m_3^b \times 1,5$		
		Human comfort	According to A.4 and not more than $m_2^a \times 1,5$ or according to A.5 and not more than $m_3^b \times 1,5$		
	Other applications	$20\% \times \text{LFL} \times \text{Room volume}$ and not more than $m_2^a \times 1,5$ or according to A.5 and not more than $m_3^b \times 1,5$	$20\% \times \text{LFL} \times \text{Room volume}$ and not more than 25 kg^c or according to A.5 and not more than $m_3^b \times 1,5$		
		< 1 person per 10 m ²	No charge restriction ^c		
2	a	Human comfort	According to A.4 and not more than m_2^a	No charge restriction ^c	Refrigerant charge not more than m_3^b
		Other applications	$20\% \times \text{LFL} \times \text{Room volume}$ and not more than m_2^a		
	Human comfort	According to A.4 and not more than m_2^a			
		Other applications	$20\% \times \text{LFL} \times \text{Room volume}$ and not more than m_2^a		
	Human comfort	According to A.4 and not more than m_2^a			
		Other applications	$20\% \times \text{LFL} \times \text{Room volume}$ and not more than m_2^a		
		Below ground	$20\% \times \text{LFL} \times \text{Room volume}$ and not more than m_2^a		
Above ground	$20\% \times \text{LFL} \times \text{Room volume}$ and not more than 10 kg^c	$20\% \times \text{LFL} \times \text{Room volume}$ and not more than 25 kg^c			

Table A.2 — (continued)

Flammability class	Occupancy category	Location classification			
		I	II	III	IV
3	a	Human comfort	According to A.4 and not more than m_2^a	In accordance with occupancy category a, other applications	Refrigerant charge not more than m_3
		Other applications	Only sealed systems: $20\% \times \text{LFL} \times \text{Room volume}$ and not more than 1 kga	Not more than 1 kga	
		Above ground	Only sealed systems: $20\% \times \text{LFL} \times \text{Room volume}$ and not more than 1,5 kga	Not more than 5 kgc	
	Human comfort	According to A.4 and not more than m_2^a	In accordance with occupancy category b, other applications		
	b	Below ground	$20\% \times \text{LFL} \times \text{Room volume}$ and not more than 1 kga	Not more than 1 kga	
		Above ground	$20\% \times \text{LFL} \times \text{Room volume}$ and not more than 2,5 kga	Not more than 10 kgc	
c	Human comfort	According to A.4 and not more than m_2^a	In accordance with occupancy category c, other applications		
	Other applications	Below ground	$20\% \times \text{LFL} \times \text{Room volume}$ and not more than 1 kgc	Not more than 1 kg	
		Above ground	$20\% \times \text{LFL} \times \text{Room volume}$ and not more than 10 kgc	No charge restrictionc	

a $m_2 = 26 \text{ m}^3 \times \text{LFL}$.

b $m_3 = 130 \text{ m}^3 \times \text{LFL}$.

c ISO 5149-3:—, 5.2 and 8.1 applies.

A.3 Factory-sealed appliances with a charge of less than 0,15 kg of A3 refrigerants

For factory-sealed appliances containing not more than 0,15 kg of A3 refrigerant according to ISO 817, the requirements of IEC 60335-2-24 and IEC 60335-2-89, as applicable, shall be applied.

A.4 Charge limitations due to flammability for A/C systems or heat pumps for human comfort: refrigerant-containing parts in an occupied space

When the charge of refrigerants with flammability class 2L is greater than $m_1 \times 1,5$, the charge in the room shall be in accordance with Formula (A.4). When the maximum charge of refrigerants with flammability classes 2 and 3 is greater than m_1 , the charge in the room shall be in accordance with Formula (A.4).

$$m_{\max} = 2,5 \times \text{LFL}^{5/4} \times h_0 \times A^{1/2} \quad (\text{A.4})$$

where

- m_{\max} is the allowable maximum charge in a room, expressed in kilograms;
- m is the refrigerant charge amount in the system, expressed in kilograms;
- A_{\min} is the required minimum room area, expressed in square metres;
- A is the room area, expressed in square metres;
- LFL is the Lower Flammability Limit, expressed in kilograms per cubic metre;
- h_0 is the height factor based upon the method of mounting the appliance.

NOTE For guidance, the following height can be considered:

- 0,6 m for floor location;
- 1,0 m for window mounted;
- 1,8 m for wall mounted;
- 2,2 m for ceiling mounted.

If Formula (A.4) produces the larger value, the required minimum floor area A_{\min} , in square metres, to install a system with refrigerant charge m , in kilograms, shall be in accordance with Formula A.5:

$$A_{\min} = \left(\frac{m}{2,5 \times \text{LFL}^{5/4} \times h_0} \right)^2 \quad (\text{A.5})$$

where LFL is expressed in kilograms per cubic metre (see [Annex B](#)) and the relative molar mass of the refrigerant is greater than 42.

A.5 Alternative for risk management of refrigerating systems in occupied spaces

A.5.1 General

Where the combination of location classification and occupancy classification shown in [Tables A.1](#) and [A.2](#) allow the use of the alternative provisions, then the designer can choose (for some or all of the occupied spaces served by the equipment) to calculate the allowable refrigerant charge using the RCL,

QLMV, or QLAV values given in [A.5.2](#) instead of the practical limit values given in [Tables B.1](#) and [B.2](#). All occupied spaces, where refrigerant-containing parts are located, shall be considered in calculating the system charge.

This subclause should only be used for an occupied space where the equipment fulfils all of the following conditions:

- systems where the refrigerant is classified as A1 or A2L according to [Annex B](#);
- systems where the refrigerant charge does not exceed 150 kg and furthermore does not exceed $195 \text{ m}^3 \times \text{LFL}$ for A2L refrigerants;
- systems where the rated cooling/heating capacity of the indoor unit is not more than 25 % of the total cooling/heating capacity of the outdoor unit;
- equipment location is class II, in accordance with [5.3.4](#);
- systems where the heat exchanger in the indoor unit and the control of the system are designed to prevent damage due to ice formation or freezing;
- systems where the refrigerant-containing parts of the indoor unit are protected against fan breakage or the fan is so designed to prevent breakage;
- systems where the equipment pipes in the occupied space in question are sized to suit the capacity of the heat exchanger in that space and connected to that heat exchanger;
- systems where only permanent joints are used in the occupied space in question except for site-made joints directly connecting the indoor unit to the piping;
- systems where the equipment pipes in the occupied space in question are installed in such a way that it is protected against accidental damage, in accordance with ISO 5149-2:2014, 5.2.3.9 and ISO 5149-3:2014, 6.2;
- special provisions to ensure safety are provided, in accordance with [A.5.2.2](#) and [A.5.2.3](#);
- doors of the occupied space are not tight-fitting;
- effect of flow down is considered, in accordance with [A.5.2.4](#).

Provided all the above conditions are fulfilled, the maximum leakage in the occupied space is deemed to be not greater than that resulting of a pinhole leak, and the maximum charge can be calculated on that basis.

A.5.2 Allowable charge

A.5.2.1 General

For occupied spaces exceeding 250 m², the charge limits calculation shall use 250 m² as the room floor area for the determination of the room volume.

The total charge of the system divided by the room volume shall not exceed the QLMV value specified in [Table A.3](#) (or if the lowest floor is underground, the RCL value in [Table A.4](#)) unless appropriate measure are taken. If the value exceeds the QLMV or RCL, appropriate measures shall be taken in accordance with [A.5.2.2](#) or [A.5.2.3](#). The appropriate measure shall be ventilation (natural or mechanical), safety shut-off valves, and safety alarm, in conjunction with a gas detection device. See ISO 5149-3:2014, Clauses 6, 8, 9, and 10. A safety alarm alone shall not be considered as an appropriate measure where occupants are restricted in their movement (see ISO 5149-3:2014, 8.1).

NOTE 1 For systems that are installed and operated within the constraints of [A.5.1](#), the risk of rapid release of refrigerant through a major leak has been minimized. The calculation of ventilation rate in [Annex A](#) has therefore been based on a maximum leakage rate of 10 kg/h.

NOTE 2 QLMV is based on a room height of 2,2 m and an opening of 0,003 2 m² (0,8 m width door and 4 mm gap) that can be expected in rooms without designed ventilation.

NOTE 3 QLAV is based on an oxygen concentration of 18,5 vol %, assuming perfect mixing.

Table A.3 — Allowable refrigerant concentration

Refrigerant	Allowable concentration kg/m ³ RCL	QLMV kg/m ³	QLAV kg/m ³
R22	0,21	0,28	0,50
R134a	0,21	0,28	0,58
R407C	0,27	0,46	0,50
R410A	0,39	0,42	0,42
R744	0,072	0,074	0,18
R32	0,061	0,063	0,16
R1234yf	0,060	0,062	0,15

For refrigerants not listed in [Table A.3](#), Formula (A.6) shall be used for the calculation of QLMV:

$$QLMV = \frac{T \times \dot{m}}{V} \tag{A.6}$$

where

T is the time where $\frac{x}{V} = \text{RCL}$ and is found by solving $dx = \left(\dot{m} - \frac{x}{V} \times A \times c \sqrt{\frac{(\rho - \rho_a) \times 2 \times h}{\rho}} \right) \times dt$;

x is the refrigerant mass in the room, in kilograms;

\dot{m} is the leak rate from refrigerating system (10 kg/h);

V is the room volume, in cubic metres;

t is the time, in seconds;

A is the opening area, in square metres, assumed to give a minimum ventilation rate, such as an area of $0,004 \times 0,8 = 0,003 2$;

c is the flow coefficient (0,7 for orifice);

ρ is the density of refrigerant air mixture, in kilograms per cubic metre, such as

$$\rho = \frac{x}{V} + \rho_a - \frac{x}{V} \frac{\rho_a}{\rho_r};$$

ρ_a is the air density, in kilograms per cubic metre;

ρ_r is the refrigerant density, in kilograms per cubic metre;

h is the refrigerant mass in the room, in kilograms.

The QLMV of refrigerants with relative molar mass between 50 g/mol and 125 g/mol can be determined by linear interpolation of the values given in [Table A.4](#).

Table A.4 — Interpolation table for calculating QLMV

RCL	Molar mass			
	50	75	100	125
0,05	0,051	0,051	0,051	0,051
0,10	0,106	0,107	0,108	0,108
0,15	0,168	0,173	0,175	0,176
0,20	0,242	0,254	0,260	0,263
0,25	0,336	0,367	0,383	0,393
0,30	0,495	0,565	0,634	0,689
0,35	0,725	—	—	—

A.5.2.2 Occupancies except ones on the lowest underground floor of the building

Where the refrigerant charge divided by the room volume does not exceed the QLMV, no additional measures are required.

Where the value is more than the QLMV but less than or equal to QLAV value, at least one of the measures described in ISO 5149-3:2014, Clauses 6 and 8 shall be taken into account. Where the value exceeds the QLAV, at least two of the specified measures shall be taken.

A.5.2.3 Occupancies on the lowest underground floor of the building

Where the refrigerant charge divided by the room volume is more than the RCL value in [Table B.1](#) but less than or equal to QLMV value, at least one of the measures described in ISO 5149-3:2014, Clauses 6, 8, and 9 shall be taken. Where the value exceeds the QLMV, at least two of the specified measures shall be taken into account. The value shall not exceed QLAV value.

A.5.2.4 Effect of flow down

Even if there is no refrigerating system on the lowest floor, where the largest system charge in the building divided by the total volume of the lowest floor exceeds QLMV value, mechanical ventilation shall be provided in accordance with ISO 5149-3:2014, 6.3.

Annex B
(normative)

Safety classification and information about refrigerants

See [Tables B.1](#), [B.2](#), and [B.3](#).

Table B.1 — Refrigerants designation

Refrigerant number	Chemical name ^b	Chemical formula	Safety group	Practical limit kg/m ³	ATEL/ODLf kg/m ³	Flammability LFL ^g kg/m ³	Vapour density 25°C, 101,3 kPa ^a kg/m ³	Relative molar mass ^a	Normal boiling point ^a °C	ODP ^{ad}	GWP ^{ae} (100 yr ITH)	Auto-ignition temperature °C
Methane series												
11	Trichlorofluoromethane	CCl ₃ F	A1	0,3	0,006 2	NF	5,62	137,4	24	1	4 750	ND
12	Dichlorodifluoromethane	CCl ₂ F ₂	A1	0,5	0,088	NF	4,94	120,9	-30	1	10 900	ND
12B1	Bromochlorodifluoromethane	CBrClF ₂	ND	0,2	ND	NF	6,76	165,4	-4	3	1 890	ND
13	Chlorotrifluoromethane	CClF ₃	A1	0,5	ND	NF	4,27	104,5	-81	1	14 400	ND
13B1	Bromotrifluoromethane	CBrF ₃	A1	0,6	ND	NF	6,09	148,9	-58	10	7 140	ND
14	Carbon tetrafluoride	CF ₄	A1	0,4	0,40	NF	3,60	88,0	-128	0	7 390	ND
22	Chlorodifluoromethane	CHClF ₂	A1	0,3	0,21	NF	3,54	86,5	-41	0,055	1 810	635
23	Trifluoromethane	CHF ₃	A1	0,68	0,15	NF	2,86	70,0	-82	0	14 800	765
30	Dichloromethane (methylene chloride)	CH ₂ Cl ₂	B1	0,017	ND	NF	3,47	84,9	40	ND	8,7	662
32	Difluoromethane (methylene fluoride)	CH ₂ F ₂	A2L	0,061	0,30	0,307	2,13	52,0	-52	0	675	648
50	Methane	CH ₄	A3	0,006	ND	0,032	0,654	16,0	-161	0	25	645

Table B.1 — (continued)

Refrigerant number	Chemical name ^b	Chemical formula	Safety group	Practical limit kg/m ³	ATEL/ODL ^f kg/m ³	Flammability LFL ^g kg/m ³	Vapour density 25°C, 101,3 kPa ^a kg/m ³	Relative molar mass ^a	Normal boiling point ^a °C	ODP ^{ad}	GWPa ^e (100 yr ITH)	Auto-ignition temperature °C
Ethane series												
113	1,1,2-trichloro-1,2,2-trifluoroethane	CCl ₂ FCClF ₂	A1	0,4	0,02	NF	7,66	187,4	48	0,8	6 130	ND
114	1,2-dichloro-1,1,2,2-tetrafluoroethane	CClF ₂ CClF ₂	A1	0,7	0,14	NF	6,99	170,9	4	1	10 000	ND
115	Chloropentafluoroethane	CClF ₂ CF ₃	A1	0,76	0,76	NF	6,32	154,5	-39	0,6	7 370	ND
116	Hexafluoroethane	CF ₃ CF ₃	A1	0,68	0,68	NF	5,64	138,0	-78	0	12 200	ND
123	2,2-dichloro-1,1,1-trifluoroethane	CHCl ₂ CF ₃	B1	0,10	0,057	NF	6,25	152,9	27	0,02	77	730
124	2-chloro-1,1,1,2-tetrafluoroethane	CHClFCF ₃	A1	0,11	0,056	NF	5,58	136,5	-12	0,022	609	ND
125	Pentafluoroethane	CHF ₂ CF ₃	A1	0,39	0,37	NF	4,91	120,0	-49	0	3 500	733
134a	1,1,1,2-tetrafluoroethane	CH ₂ FCF ₃	A1	0,25	0,21	NF	4,17	102,0	-26	0	1 430	743
141b	1,1-dichloro-1-fluoroethane	CH ₃ CCl ₂ F	ND	0,053	0,012	0,363	4,78	116,9	32	0,11	725	532
142b	1-chloro-1,1-difluoroethane	CH ₃ CClF ₂	A2	0,049	0,10	0,329	4,11	100,5	-10	0,065	2 310	750
143a	1,1,1-trifluoroethane	CH ₃ CF ₃	A2L	0,048	0,48	0,282	3,44	84,0	-47	0	4 470	750
152a	1,1-difluoroethane	CH ₃ CHF ₂	A2	0,027	0,14	0,130	2,70	66,0	-25	0	124	455
170	Ethane	CH ₃ CH ₃	A3	0,008 6	0,008 6	0,038	1,23	30,1	-89	0	5,5	515
1150	Ethene (ethylene)	CH ₂ = CH ₂	A3	0,006	ND	0,036	1,15	28,1	-104	0	3,7	ND
E170	Dimethyl Ether	CH ₃ OCH ₃	A3	0,013	0,079	0,064	1,88	46	-25	0	1	235

Table B.1 — (continued)

Refrigerant number	Chemical name ^b	Chemical formula	Safety group	Practical limit kg/m ³	ATEL/ODLf kg/m ³	Flammability LFL ^g kg/m ³	Vapour density 25°C, 101,3 kPa ^a kg/m ³	Relative molar mass ^a	Normal boiling point ^a °C	ODP ^{ad}	GWPa ^e (100 yr ITH)	Auto- ignition tempe- rature °C
Propane series												
218	Octafluoropropane	CF ₃ CF ₂ CF ₃	A1	1,84	0,85	NF	7,69	188,0	-37	0	8 830	ND
227ea	1,1,1,2,3,3,3-heptafluoropropane	CF ₃ CHF ₂ CF ₃	A1	0,63	0,63	NF	6,95	170,0	-15	0	3 220	ND
236fa	1,1,1,3,3,3-hexafluoropropane	CF ₃ CH ₂ CF ₃	A1	0,59	0,34	NF	6,22	152,0	-1	0	9 810	ND
245fa	1,1,1,3,3-pentafluoropropane	CF ₃ CH ₂ CHF ₂	B1	0,19	0,19	NF	5,48	134,0	15	0	1 030	ND
290	Propane	CH ₃ CH ₂ CH ₃	A3	0,008	0,09	0,038	1,80	44,1	-42	0	3,3	470
1234yf	2,3,3,3-tetrafluoroprop-1-ene	CF ₃ CF = CH ₂	A2L	0,058	0,47	0,289	4,66	114,0	-26	0	4 ⁱ	405
1234ze(E)	trans-1,3,3,3-tetrafluoroprop-1-ene	CF ₃ CH = CFH	A2L	0,061	0,28	0,303	4,66	114,0	-19	0	7 ⁱ	368
1270	Propene (propylene)	CH ₃ CH = CH ₂	A3	0,008	0,001 7	0,046	1,72	42,1	-48	0	1,8	455
Other hydrocarbons												
600	Butane	CH ₃ CH ₂ CH ₂ CH ₃	A3	0,008 9	0,002 4	0,038	2,38	58,1	0	0	4,0	365
600a	2-methyl propane (isobutane)	CH(CH ₃) ₂ CH ₃	A3	0,011	0,059	0,043	2,38	58,1	-12	0	~20 ^h	460
601	Pentane	CH ₃ CH ₂ CH ₂ CH ₂ CH ₃	A3	0,008	0,0029	0,035	2,95	72,1	36	0	~20 ^h	ND
601a	2-methyl butane (isopentane)	(CH ₃) ₂ CHCH ₂ CH ₃	A3	0,008	0,0029	0,038	2,95	72,1	27	0	~20 ^h	ND

Table B.1 — (continued)

Refrigerant number	Chemical name ^b	Chemical formula	Safety group	Practical limit kg/m ³	ATEL/ODL ^f kg/m ³	Flammability LFL ^g kg/m ³	Vapour density 25 °C, 101,3 kPa ^a kg/m ³	Relative molar mass ^a	Normal boiling point ^a °C	ODP ^{ad}	GWPa ^e (100 yr ITH)	Auto-ignition temperature °C
Cyclic organic compounds												
C318	Octafluorocyclobutane	-(CF ₂) ₄	A1	0,81	0,65	NF	8,18	200,0	-6	0	10 300	ND
Inorganic compounds												
717	Ammonia	NH ₃	B2L	0,000 35	0,000 22	0,116	0,700	17,0	-33	0	<1 ^h	630
744	Carbon dioxide	CO ₂	A1	0,1	0,072	NF	1,80	44,0	-78 ^c	0	1	NA
NOTE 1	See Tables B.2 and B.3 for zeotropic and azeotropic blends.											
NOTE 2	NA signifies not applicable.											
NOTE 3	ND signifies not determined.											
NOTE 4	NF signifies non flammable.											
^a	The vapour density, normal boiling point, ODP, and GWP are not part of this International Standard, and are provided for information purposes only.											
^b	The preferred chemical name is followed by the popular name in parentheses.											
^c	Sublimes. Triple point is -56,6 °C at 5,2 bar.											
^d	Adopted under the Montreal Protocol.											
^e	Data from IPCC 4th assessment report 2007. When not available, WMO Scientific assessment of ozone depletion 2010 is used as first priority and then the UNEP RTOC 2010 report.											
^f	Acute-Toxicity Exposure Limit or Oxygen Deprivation Limit, whichever is lower, values taken from ISO 817.											
^g	Lower Flammability Limit.											
^h	Data from UNEP RTOC 2010 report.											
ⁱ	Data from WMO Scientific assessment of ozone depletion 2010.											

Table B.2 — Refrigerant designations of zeotropic blends (R-400 series)

Refrigerant number	Composition ^c mass %	Composition tolerances	Safety group	Practical limit ^d	ATEL/ ODL ^g	Flammability LFL ^h	Vapour density 25 °C, 101,3 kPa ^a	Relative molar mass ^a	Bubble point/dew point ^a at 101,3 kPa	ODPa ^e	GWPa ^f (100 yr ITP)	Auto-ignition temperature
												°C
401A	R-22/152a/124 (53/13/34)	±2/+0,5 -1,5/±1	A1/A1	0,30	0,10	NF	3,86	94,4	-33,4/-27,8	0,037	1 180	681
401B	R-22/152a/124 (61/11/28)	±2/+0,5 -1,5/±1	A1/A1	0,34	0,11	NF	3,80	92,8	-34,9/-29,6	0,04	1 290	685
401C	R-22/152a/124 (33/15/52)	±2/+0,5 -1,5/±1	A1/A1	0,24	0,083	NF	4,13	101,0	-28,9/-23,3	0,03	933	ND
402A	R-125/290/22 (60/2/38)	±2/+0,1 -1,0/±2	A1/A1	0,33	0,27	NF	4,16	101,6	-49,2/-47,0	0,021	2 790	723
402B	R-125/290/22 (38/2/60)	±2/+0,1 -1,0/±2	A1/A1	0,32	0,24	NF	3,87	94,7	-47,2/-44,8	0,033	2 420	641
403A	R-290/22/218 (5/75/20)	+0,2 -2,0/±2/±2	A1/A2	0,33	0,24	0,480	3,76	92,0	-44,0/-42,4	0,041	3 120	ND
403B	R-290/22/218 (5/56/39)	+0,2 -2,0/±2/±2	A1/A1	0,41	0,29	NF	4,22	103,3	-43,9/-42,4	0,031	4 460	ND
404A	R-125/143a/134a (44/52/4)	±2/±1/±2	A1/A1	0,52	0,52	NF	3,99	97,6	-46,5/-45,7	0	3 920	728
405A	R-22/152a/142b/C318 (45/7/5,5/42,5)	±2/±1/±1/±2 ^b	ND	ND	0,26	ND	4,58	111,9	-32,8/-24,4	0,028	5 330	ND
406A	R-22/600a/142b (55/4/41)	±2/±1/±1	A2/A2	0,13	0,14	0,302	3,68	89,9	-32,7/-23,5	0,057	1 940	ND
407A	R-32/125/134a (20/40/40)	±2/±2/±2	A1/A1	0,33	0,31	NF	3,68	90,1	-45,2/-38,7	0	2 110	685
407B	R-32/125/134a (10/70/20)	±2/±2/±2	A1/A1	0,35	0,33	NF	4,21	102,9	-46,8/-42,4	0	2 800	703
407C	R-32/125/134a (23/25/52)	±2/±2/±2	A1/A1	0,31	0,29	NF	3,53	86,2	-43,8/-36,7	0	1 770	704
407D	R-32/125/134a (15/15/70)	±2/±2/±2	A1/A1	0,41	0,25	NF	3,72	91,0	-39,4/-32,7	0	1 630	ND
407E	R-32/125/134a (25/15/60)	±2/±2/±2	A1/A1	0,40	0,27	NF	3,43	83,8	-42,8/-35,6	0	1 550	ND
407F	R-32/125/134a (30/30/40)	±2/±2/±2	A1/A1	0,32	0,32	NF	3,36	82,1	-46,1/-39,7	0	1 820	ND
408A	R-125/143a/22 (7/46/47)	±2/±1/±2	A1/A1	0,41	0,33	NF	3,56	87,0	-44,6/-44,1	0,026	3 150	ND
409A	R-22/124/142b (60/25/15)	±2/±2/±1	A1/A1	0,16	0,12	NF	3,98	97,4	-34,7/-26,3	0,048	1 580	ND
409B	R-22/124/142b (65/25/10)	±2/±2/±1	A1/A1	0,17	0,12	NF	3,95	96,7	-35,8/-28,2	0,048	1 560	ND
410A	R-32/125 (50/50)	+0,5 -1,5/+1,5-0,5	A1/A1	0,44	0,42	NF	2,97	72,6	-51,6/-51,5	0	2 090	ND
410B	R-32/125 (45/55)	±1/±1	A1/A1	0,43	0,43	NF	3,09	75,6	-51,5/-51,4	0	2 230	ND
411A	R-1270/22/152a (1,5/87,5/11,0)	+0,-1/+2,-0/+0-1	A1/A2	0,04	0,074	0,186	3,37	82,4	-39,6/-37,1	0,048	1 600	ND
411B	R-1270/22/152a (3/94/3)	+0,-1/+2,-0/+0-1	A1/A2	0,05	0,044	0,239	3,40	83,1	-41,6/-40,2	0,052	1 710	ND
412A	R-22/218/142b (70/5/25)	±2/±2/±1	A1/A2	0,07	0,17	0,329	3,77	92,2	-36,5/-28,9	0,055	2 290	ND
413A	R-218/134a/600a (9/88/3)	±1/±2/+0 -1	A1/A2	0,08	0,21	0,375	4,25	104,0	-29,4/-27,4	0	2 050	ND

Table B.2 (continued)

Refrigerant number	Composition ^c mass %	Composition tolerances	Safety group	Practical limit ^d	ATEL/ ODL ^g	Flammability LFL ^h	Vapour density 25 °C, 101,3 kPa ^a	Relative molar mass ^a	Bubble point/dew point ^a at 101,3 kPa	ODPa ^e	GWPa f (100 yr ITH)	Auto-ignition temperature
		%		kg/m ³	kg/m ³	kg/m ³	kg/m ³		°C			°C
414A	R-22/124/600a/142b (51,0/28,5/4,0/16,5)	±2/±2/±0,5/+0,5-1,0	A1/A1	0,10	0,10	NF	3,96	96,9	-33,2/-24,7	0,045	1 480	ND
414B	R-22/124/600a/142b (50,0/39,0/1,5/9,5)	±2/±2/±0,5/+0,5-1,0	A1/A1	0,096	0,096	NF	4,16	101,6	-33,1/-24,7	0,042	1 360	ND
415A	R-22/152a (82/18)	±1/±1	A2	0,04	0,19	0,188	3,35	81,9	-37,5/-34,7	0,028	1 510	ND
415B	R-22/152a (25,0/75,0)	±1/±1	A2	0,03	0,15	0,13	2,87	70,2	-23,4/-21,8	0,009	546	ND
416A	R-134a/124/600 (59,0/39,5/1,5)	+0,5-1,0/+1,0 -0,5/+0,1-0,2	A1/A1	0,064	0,064	NF	4,58	111,9	-23,4/-2,8	0,009	1 080	ND
417A	R-125/134a/600 (46,6/50,0/3,4)	±1,1/±1,0/+0,1-0,4	A1/A1	0,15	0,057	NF	4,36	106,7	-38,0/-32,9	0	2 350	ND
417B	R-125/134a/600 (79,0/18,3/2,7)	±1,0/±1,0/+0,1-0,5	A1/A1	0,069	0,069	NF	4,63	113,1	-44,9/-41,5	0	3 030	ND
418A	R-290/22/152a (1,5/96,0/2,5)	±0,5/±1/±0,5	A1/A2	0,06	0,20	0,31	3,46	84,6	-41,7/-40,0	0,033	1 740	ND
419A	R-125/134a/E170 (77/19/4)	±1/±1/±1	A1/A2	0,05	0,31	0,25	4,47	109,3	-42,6/-36,0	0	2 970	ND
420A	R-134a/142b (88/12)	+1-0/0-1	A1/A1	0,18	0,18	NF	4,16	101,8	-24,9/-24,2	0,005	1 540	ND
421A	R-125/134a (58,0/42,0)	±1,0/±1,0	A1/A1	0,28	0,28	NF	4,57	111,7	-40,8/-35,5	0	2 630	ND
421B	R-125/134a (85,0/15,0)	±1,0/±1,0	A1/A1	0,33	0,33	NF	4,78	116,9	-45,7/-42,6	0	3 190	ND
422A	R-125/134a/600a (85,1/11,5/3,4)	±1,0/±1,0/+0,1-0,4	A1/A1	0,29	0,29	NF	4,65	113,6	-46,5/-44,1	0	3 140	ND
422B	R-125/134a/600a (55,0/42,0/3,0)	±1,0/±1,0/+0,1-0,5	A1/A1	0,25	0,25	NF	4,44	108,5	-40,5/-35,6	0	2 530	ND
422C	R-125/134a/600a (82,0/15,0/3,0)	±1,0/±1,0/+0,1-0,5	A1/A1	0,29	0,29	NF	4,64	113,4	-45,3/-42,3	0	3 090	ND
422D	R-125/134a/600a (65,1/31,5/3,4)	+0,9-1,1/±1,0/+0,1-0,4	A1/A1	0,26	0,26	NF	4,49	109,9	-43,2/-38,4	0	2 730	ND
423A	R-134a/227ea (52,5/47,5)	±1,0/±1,0	A1/A1	0,30	0,30	NF	5,15	126,0	-24,2/-23,5	0	2 280	ND
424A	R-125/134a/600a/600/601a (50,5/47,0/0,9/1,0/0,6)	±1,0/±1,0/+0,1-0,2/ +0,1-0,2/+0,1-0,2	A1/A1	0,10	0,10	NF	4,43	108,4	-39,1/-33,3	0	2 440	ND
425A	R-32/134a/227ea (18,5/69,5/12,0)	±0,5/±0,5/±0,5	A1/A1	0,27	0,27	NF	3,69	90,3	-38,1/-31,3	0	1 510	ND

Table B.2 — (continued)

Refrigerant number	Composition ^c mass %	Composition tolerances	Safety group	Practical limit ^d	ATEL/ ODL ^g	Flammability LFL ^h	Vapour Density 25 °C, 101,3 kPa ^a	Relative molar mass ^a	Bubble point/ dew point ^a at 101,3 kPa	ODP ^a e	GWPa ^f (100 yr ITH)	Auto-ignition temperature
		%		kg/m ³	kg/m ³	kg/m ³	kg/m ³		°C			°C
426A	R-125/134a/600/601a (5,1/93,0/1,3/0,6)	±1,0/±1,0/+0,1-0,2/ +0,1-0,2	A1/A1	0,083	0,083	NF	4,16	101,6	-28,5/-26,7	0	1 510	ND
427A	R-32/125/143a/134a (15,0/25,0/10,0/50,0)	±2,0/±2,0/±2,0/±2,0	A1/A1	0,29	0,29	NF	3,70	90,4	-43,0/-36,3	0	2 140	ND
428A	R-125/143a/290/600a (77,5/20,0/0,6/1,9)	±1,0/±1,0/+0,1-0,2/ +0,1-0,2	A1/A1	0,37	0,37	NF	4,40	107,5	-48,3/-47,5	0	3 610	ND
429A	R-E170/152a/600a (60,0/10,0/30,0)	±1,0/±1,0/±1,0	A3/A3	0,010	0,098	0,052	2,08	50,8	-26,0/-25,6	0	19	ND
430A	R-152a/600a (76,0/24,0)	±1,0/±1,0	A3/A3	0,017	0,10	0,084	2,61	63,9	-27,6/-27,4	0	99	ND
431A	R-290/152a (71,0/29,0)	±1,0/±1,0	A3/A3	0,009	0,10	0,044	2,00	48,8	-43,1/-43,1	0	38	ND
432A	R-1270/E170 (80,0/20,0)	±1,0/±1,0	A3/A3	0,008	0,002 1	0,039	1,75	42,8	-46,6/-45,6	0	2	ND
433A	R-1270/290 (30,0/70,0)	±1,0/±1,0	A3/A3	0,007	0,005 5	0,036	1,78	43,5	-44,6/-44,2	0	3	ND
433B	R-1270/290 (5,0/95,0)	±1,0/±1,0	A3/A3	0,005	0,025	0,025	1,80	44,0	-42,7/-42,5	0	3	ND
433C	R-1270/290 (25,0/75,0)	±1,0/±1,0	A3/A3	0,006	0,006 6	0,032	1,78	43,6	-44,3/-43,9	0	3	ND
434A	R-125/143a/134a/600a (63,2/18,0/16,0/2,8)	±1,0/±1,0/±1,0/+0,1-0,2	A1/A1	0,32	0,32	NF	4,32	105,7	-45,0/-42,3	0	3 250	ND
435A	R-E170/152a (80,0/20,0)	±1,0/±1,0	A3/A3	0,014	0,09	0,069	2,00	49,0	-26,1/-25,9	0	26	ND
436A	R-290/600a (56,0/44,0)	±1,0/±1,0	A3/A3	0,006	0,073	0,032	2,02	49,3	-34,3/-26,2	0	11	ND
436B	R-290/600a (52,0/48,0)	±1,0/±1,0	A3/A3	0,007	0,071	0,033	2,00	49,9	-33,4/-25,0	0	11	ND
437A	R-125/134a/600/601 (19,5/78,5/1,4/0,6)	+0,5-1,8/+1,5-0,7/ +0,1-0,2/+0,1-0,2	A1/A1	0,081	0,081	NF	4,24	103,7	-32,9/-29,2	0	1 810	ND

Table B.2 — (continued)

Refrigerant number	Composition ^c mass %	Composition tolerances	Safety group	Practical limit ^d	ATEL/ ODL _g	Flammability LFL _h	Vapour Density 25 °C, 101,3 kPa ^a	Relative molar mass	Bubble point/ dew point ^a at 101,3 kPa	ODP _e	GWPa _f (100 yr ITH)	Auto-ignition temperature
		%		kg/m ³	kg/m ³	kg/m ³	kg/m ³		°C			°C
438A	R-32/125/134a/600/601a (8,5/45,0/44,2/1,7/0,6)	+0,5/-1,5/±1,5/±1,5/ +0,1/-0,2/+0,1/-0,2	A1/A1	0,079	0,079	NF	4,05	99,1	-43,0/-36,4	0	2 260	ND
439A	R-32/125/600a (50,0/47,0/3,0)	±1,0/±1,0/±0,5	A2/A2	0,061	0,34	0,304	2,91	71,2	-52,0/-51,8	0	1 980	ND
440A	R-290/134a/152a (0,6/1,6/97,8)	±0,1/±0,6/±0,5	A2/A2	0,025	0,14	0,124	2,71	66,2	-25,5/-24,3	0	144	ND
441A	R-170/290/600a/600 (3,1/54,8/6,0/36,1)	±0,3/±2,0/±0,6/±2,0	A3/A3	0,006 3	0,006 3	0,032	1,98	48,3	-41,9/-20,4	0	5	ND
442A	R-32/125/134a/152a/227ea (31,0/31,0/30,0/3,0/5,0)	±1,0/±1,0/±1,0/±0,5/±1,0	A1/A1	0,33	0,33	NF	3,35	81,8	-46,5/-52,7	0	1 890	ND

a ODP, GWP, vapour density, "bubble point", and "dew point" temperatures are not part of this International Standard; they are provided for information only. The "bubble point temperature" is defined as the liquid saturation temperature of a refrigerant at the specified pressure, the temperature at which a liquid refrigerant first begins to boil. The bubble point of a zeotropic refrigerant blend, at constant pressure, is lower than the dew point. The "dew point temperature" is defined as the vapour saturation temperature of a refrigerant at the specified pressure, the temperature at which the last drop of liquid refrigerant boils. The dew point of a zeotropic refrigerant blend, at constant pressure, is higher than the bubble point.

b The sum of the composition tolerances for R152a and R142b shall be between 0 and -2 %.

c Blend components are conventionally listed in order of increasing normal boiling point.

d Practical Limit, calculated from the values for the individual components as listed in [Table B.1](#).

e Ozone Depletion Potential, calculated from the values for the individual components as listed in [Table B.1](#).

f Global Warming Potential, calculated from the values for the individual components as listed in [Table B.1](#).

g Acute-Toxicity Exposure Limit or Oxygen Deprivation Limit, whichever is lower.

h Lower Flammability Limit.

Table B.3 — Refrigerant designations of azeotropic blends^a (R-500 series)

Refrigerant number	Azeotropic composition ^e mass %	Composition tolerances	Safety group	Practical limit	ATEL/ODL ^g	Flammability LFL ^h	Vapour density 25 °C, 101,3 kPa ^b	Relative molar mass ^b	Normal boiling point ^b	Azeotropic temperature	ODP ^{bi}	GWP ^{bf} (100 yr ITH)	Auto-ignition temperature
500	R-12/152a (73,8/26,2)	+1,0 -0,0/+0,0 -1,0	A1/A1	0,4	0,12	NF	4,06	99,3	-33	0	0,74	8 080	ND
501	R-22/12 (75,0/25,0) ^c		A1/A1	0,38	0,21	NF	3,81	93,1	-41	-41	0,29	4 080	ND
502	R-22/115 (48,8/51,2)		A1/A1	0,45	0,33	NF	4,56	111,6	-45	19	0,33	4 660	ND
503	R-23/13 (40,1/59,9)		A1/A1	0,35	ND	NF	3,58	87,5	-88	88	0,6	14 600	ND
504	R-32/115 (48,2/51,8)		A1/A1	0,45	0,45	NF	3,24	79,2	-57	17	0,31	4 140	ND
507A	R-125/143a (50/50)	+1,5 -0,5/+0,5 -1,5	A1/A1	0,53	0,53	NF	4,04	98,9	-46	-40	0	3 990	ND
508A	R-23/116 (39/61)	±2,0/±2,0	A1/A1	0,23	0,23	NF	4,09	100,1	-86	-86	0	13 200	ND
508B	R-23/116 (46/54)	±2,0/±2,0	A1/A1	0,25	0,2	NF	3,90	95,4	-88	-45,6	0	13 400	ND
509A	R-22/218 (44/56)	±2,0/±2,0	A1/A1	0,56	0,38	NF	5,07	124,0	-47	0	0,024	5 740	ND
510A	R-E170/600a (88,0/12,0)	±0,5/±0,5	A3/A3	0,011	0,087	0,056	1,93	47,2	-25	-25,2	0	3	ND
511A	R-290/E170 (95,0/5,0)	±1,0/±1,0	A3/A3	0,008	0,092	0,038	1,81	44,2	-42	-20 to +40	0	3	ND
512A	R-134a/152a (5,0/95,0)	±1,0/±1,0	A2/A2	0,025	0,14	0,124	2,75	67,2	-24	-20 to +40	0	189	ND

^a Azeotropic refrigerants exhibit some segregation of components at conditions of temperature and pressure other than those at which they are formulated. The extent of segregation depends on the particular azeotrope and hardware system configuration.

^b ODP, GWP, vapour density, molecular mass, and normal boiling point are not part of this International Standard, but are provided for informative purposes only.

^c The exact composition of this azeotrope is in question, and additional experimental studies are needed.

^d Under vapour-liquid equilibrium (VLE) conditions.

^e Blend components are conventionally listed in order of increasing normal boiling point.

^f Global Warming Potential, calculated from the values for the individual components as listed in [Table B.1](#).

^g Acute-Toxicity Exposure Limit or Oxygen Deprivation Limit, whichever is lower.

^h Lower Flammability Limit.

ⁱ Ozone Depletion Potential, calculated from the values for the individual components as listed in [Table B.1](#).

Annex C (informative)

Potential hazards for refrigerating systems

C.1 General

Refrigerants, their mixtures and combinations with oils, water, and other materials, which are present in the refrigerating system, intended or unintended, affect the internal surrounding materials chemically and physically, for example, due to pressure and temperature. They can, if they have detrimental properties, endanger persons, property, and environment directly or indirectly due to global long-term effects (ODP, GWP) when escaping from the refrigerating system. The specifications of such refrigerants, mixtures and combinations are given in relevant standards such as ISO 817, and are not included in this part of ISO 5149.

Refrigerating system pressure and temperature hazards can be caused by refrigerant in the vapour, liquid, or combined phases. Furthermore, the state of the refrigerant and the stresses that it exerts on the various components do not solely depend on the processes and functions inside the equipment, but also on external causes.

The potential hazards include from:

- a) the direct effect of extreme temperature, for example:
 - 1) brittleness of materials at low temperatures;
 - 2) freezing of enclosed liquid;
 - 3) thermal stresses;
 - 4) changes of volume due to temperature changes;
 - 5) injurious effects to persons caused by low temperatures;
 - 6) touchable hot surfaces;
- b) excessive pressure due to, for example:
 - 1) increase of the pressure of condensation, caused by inadequate cooling or the partial pressure of non-condensable gases or an accumulation of oil or liquid refrigerant;
 - 2) increase of the pressure of saturated vapour due to excessive external heating, for example, of a liquid cooler, or when defrosting an air cooler or high ambient temperature when the plant is at a standstill;
 - 3) expansion of a liquid refrigerant in a closed space without the presence of vapour, caused by a rise in extreme temperature;
 - 4) fire;
- c) the direct effect of the liquid phase, for example:
 - 1) excessive refrigerant charge or refrigerant flooding of equipment;
 - 2) presence of liquid in compressors, caused by siphoning, or condensing in the compressor;
 - 3) liquid hammering in piping;

- 4) loss of lubrication due to emulsification of oil;
- d) from the escape of refrigerants, for example:
- 1) fire;
 - 2) explosion;
 - 3) toxicity;
 - 4) caustic effects;
 - 5) freezing of skin;
 - 6) asphyxiation;
 - 7) panic;
 - 8) possible environmental issues such as depletion of the ozone layer and global warming;
- e) from the moving parts of the machinery, for example:
- 1) injury;
 - 2) hearing loss from excessive noise;
 - 3) damage due to vibration.

Annex D (informative)

Equivalent terms in English and French

D.1 General

The equivalence in English and French of the defined terms are given in [Table D.1](#).

Table D.1 — Equivalent terms in English and French

Index of the terms defined in the standard	Répertoire des termes définis dans la norme	Clause number
absorption system	système à absorption	3.1.1
Acute Toxicity Exposure Limit	limite d'exposition de toxicité aiguë	Clause 4
auto-ignition temperature	température d'inflammation spontanée	3.7.7
azeotrope	azéotrope	3.7.2
brazed joint	joint brasé fort	3.5.1
bursting disc	disque de rupture	3.6.1
cascade system	Installation en cascade	3.1.2
changeover device	inverseur	3.6.2
coil	serpentin	3.4.1
companion (block) valves	contre-robinets (ou robinets-vannes) de sectionnement	3.5.2
compressor	compresseur	3.4.2
compressor unit	groupe compresseur	3.4.2.1
compression joint	joint par compression	3.5.3
condenser	condenseur	3.4.4
condensing unit	groupe de condensation	3.4.5
crawl space	vide sanitaire	3.2.1
design pressure	pression de conception	3.3.1
dilution transfer opening	courant d'air dû à l'ouverture	3.10.3
direct releasable system	système à détente directe	3.1.3
disposal	mise à disposition	3.9.1
double indirect system	système indirect double	3.1.5
evaporator	évaporateur	3.4.6
exit	sortie	3.2.2
exit passageway	passage de sortie	3.2.3
factory-made	fabriqué en usine	3.10.1
fade-out vessel	réceptacle d'affaiblissement	3.4.8
flammability	inflammabilité	3.7.12
flanged joint	joint à bride	3.5.4
flared joint	joint évasé	3.5.5

Table D.1 (continued)

Index of the terms defined in the standard	Répertoire des termes définis dans la norme	Clause number
fusible plug	bouchon fusible	3.6.3
hallway	corridor	3.2.4
halocarbon	halocarbure	3.7.4
header	collecteur	3.5.6
heat exchanger	échangeur thermique	3.4.3
heat pump	pompe à chaleur	3.1.9
heat-transfer circuit	circuit de transfert de chaleur	3.8.1
heat-transfer fluid	fluide caloporteur	3.7.6
high-pressure side	côté haute pression	3.1.7
hydrocarbon	hydrocarbure	3.7.5
indirect systems	systèmes indirects	3.1.4
internal net volume	volume interne net	3.4.10
isolating valves	robinet d'isolation	3.5.7
joint	joint	3.5.8
limited charge systems	système à charge limitée	3.1.6
liquid level cut out	limiteur de niveau de liquides	3.6.4
liquid receiver	réservoir de liquide	3.4.9
low-pressure side	côté basse pression	3.1.8
Lower Flammability Limit	limite inférieure d'inflammabilité	3.7.5
lubricant	lubrifiant	3.7.1
machinery room	salle des machines	3.2.5
maximum allowable pressure	pression maximale admissible	3.3.3
multisplit system	système multisplit	3.1.15
non-positive displacement compressor	compresseur non volumétrique	3.4.2.3
occupied space	espace occupé par des personnes	3.2.6
open air	air libre	3.2.7
open compressor	compresseur ouvert	3.4.2.4
overflow valve	soupape de décharge	3.6.5
outside air	air extérieur	3.7.8
Oxygen Deprivation Limit	limite de privation d'oxygène	3.11.2
pipng	tuyauterie	3.5.9
positive displacement compressor	compresseur volumétrique	3.4.2.2
practical limit	limite pratique	3.7.13
pressure limiter	limiteur de pression	3.6.6
pressure relief device	dispositif limiteur de pression	3.6.7
pressure relief valve	soupape de sécurité	3.6.8
pressure vessel	réceptacle sous pression	3.4.7
Quantity Limit with Additional Ventilation	quantité limite avec ventilation supplémen- taire	3.10.3
quantity limit with minimum ventilation	quantité limite avec ventilation minimale	3.10.4

Table D.1 (continued)

Index of the terms defined in the standard	Répertoire des termes définis dans la norme	Clause number
quick closing valve	robinet à fermeture rapide	3.5.10
reclaim	régénérer	3.9.2
recover	récupérer	3.9.3
recycle	recycler	3.9.4
refrigerant	fluide frigorigène	3.7.9
Refrigerant Concentration Limit	limite de concentration du fluide frigorigène	3.11.5
refrigerant detector	détecteur de fluide frigorigène	3.6.9
refrigerating equipment	composants frigorifiques	3.4.11
refrigerating system	système de réfrigération	3.1.9
refrigerant type	type de fluide frigorigène	3.7.10
reuse	réutilisation	3.9.5
safety switching device for limiting the pressure	dispositif de sécurité de limitation de la pression	3.6.10
sealed system	système scellé	3.1.11
self closing valve	robinet à autofermeture	3.6.11
self-contained system	système autonome	3.1.10
service duct	gaine de service	3.5.11
shut-off device	dispositif d'arrêt	3.5.12
special machinery room	salle des machines spéciale	3.2.8
strength test pressure	pression de l'essai de résistance	3.3.4
surge drum	réservoir-tampon	3.4.12
system	système	3.1.12
tapered thread joint	joint fileté conique	3.5.13
temperature limiting device	dispositif de limitation de la température	3.6.12
three-way valve	robinet à trois voies	3.5.14
tightness test pressure	pression de l'essai d'étanchéité	3.3.2
toxicity	toxicité	3.7.11
type-approved component	composant ayant subi un essai de type	3.6.13
type-approved pressure cut out	pressostat ayant subi un essai de type	3.6.13.1
type-approved pressure limiter	limiteur de pression ayant subi un essai de type	3.6.13.2
type-approved safety pressure cut out	pressostat de sécurité ayant subi un essai de type	3.6.13.3
unit system	système monobloc	3.1.13
ventilated enclosure	gaine ventilée	3.2.9
welded joint	joint soudé	3.5.15
zeotrope	zéotrope	3.7.3

Bibliography

- [1] ISO 5149-4, *Refrigerating systems and heat pumps — Safety and environmental requirements — Part 4: Operation, maintenance, repair and recovery*
- [2] ISO 13043, *Road vehicles — Refrigerant systems used in mobile air conditioning systems (MAC) — Safety requirements*
- [3] SAE J 639, *Safety standards for motor vehicle refrigerant vapor compression systems*
- [4] UNEP RTOC 2010 report
- [5] WMO Scientific assessment of ozone depletion 2010
- [6] IPCC 4th assessment report 2007

