

INTERNATIONAL  
STANDARD

**ISO**  
**5049-1**

Second edition  
1994-07-01

**ANSI Internat Doc Sec**

---

---

**Mobile equipment for continuous handling  
of bulk materials —**

**Part 1:**

Rules for the design of steel structures

*Appareils mobiles de manutention continue pour produits en vrac —  
Partie 1: Règles pour le calcul des charpentes en acier*



Reference number  
ISO 5049-1:1994(E)

## Contents

	Page
<b>1</b> Scope .....	<b>1</b>
<b>2</b> Normative references .....	<b>1</b>
<b>3</b> Loads .....	<b>1</b>
<b>3.1</b> Main loads .....	<b>2</b>
<b>3.2</b> Additional loads .....	<b>4</b>
<b>3.3</b> Special loads .....	<b>8</b>
<b>4</b> Load cases .....	<b>9</b>
<b>5</b> Design of structural parts for general stress analysis .....	<b>10</b>
<b>5.1</b> General .....	<b>10</b>
<b>5.2</b> Characteristic values of materials .....	<b>10</b>
<b>5.3</b> Calculation of allowable stresses with respect to the yield point .....	<b>11</b>
<b>5.4</b> Checking of framework elements submitted to compression loads .....	<b>11</b>
<b>6</b> Design of joints for general stress checking .....	<b>13</b>
<b>6.1</b> Welded joints .....	<b>13</b>
<b>6.2</b> Bolted and riveted joints .....	<b>15</b>
<b>6.3</b> Joints using high-strength friction-grip (HSFG) bolts with controlled tightening .....	<b>17</b>
<b>6.4</b> Cables .....	<b>20</b>
<b>7</b> Calculation of allowable fatigue strength for structural members and for joints .....	<b>20</b>
<b>7.1</b> General .....	<b>20</b>
<b>7.2</b> Allowable stress, $\sigma_D$ .....	<b>20</b>
<b>7.3</b> Characteristic curves for allowable fatigue strength .....	<b>21</b>
<b>8</b> Exceeding allowable stresses .....	<b>46</b>
<b>9</b> Safety against overturning .....	<b>46</b>

© ISO 1994

All rights reserved. Unless otherwise specified, no part of this publication may be reproduced or utilized in any form or by any means, electronic or mechanical, including photocopying and microfilm, without permission in writing from the publisher.

International Organization for Standardization  
Case Postale 56 • CH-1211 Genève 20 • Switzerland

Printed in Switzerland

<b>9.1</b>	Checking for safety against overturning .....	<b>46</b>
<b>9.2</b>	Additional precautions .....	<b>46</b>
<b>10</b>	Safety against drifting .....	<b>46</b>
<b>Annex</b>		
<b>A</b>	Bibliography .....	<b>48</b>

## Foreword

ISO (the International Organization for Standardization) is a worldwide federation of national standards bodies (ISO member bodies). The work of preparing International Standards is normally carried out through ISO technical committees. Each member body interested in a subject for which a technical committee has been established has the right to be represented on that committee. International organizations, governmental and non-governmental, in liaison with ISO, also take part in the work. ISO collaborates closely with the International Electrotechnical Commission (IEC) on all matters of electrotechnical standardization.

Draft International Standards adopted by the technical committees are circulated to the member bodies for voting. Publication as an International Standard requires approval by at least 75 % of the member bodies casting a vote.

International Standard ISO 5049-1 was prepared by Technical Committee ISO/TC 101, *Continuous mechanical handling equipment*.

This second edition cancels and replaces the first edition (ISO 5049-1:1980), of which it constitutes a technical revision.

ISO 5049 consists of the following parts, under the general title *Mobile equipment for continuous handling of bulk materials*:

- *Part 1: Rules for the design of steel structures*
- *Part 2: Rules for the design of machinery*

Annex A of this part of ISO 5049 is for information only.

# Mobile equipment for continuous handling of bulk materials —

## Part 1:

## Rules for the design of steel structures

### 1 Scope

This part of ISO 5049 establishes rules for determining the loads, types and combinations of loads (main, additional and special loads) which must be taken into account when designing steel structures for mobile continuous bulk handling equipment.

This part of ISO 5049 is applicable to rail-mounted mobile equipment for continuous handling of bulk materials, especially to

- stackers,
  - shiploaders,
  - reclaimers,
  - combined stackers and reclaimers,
  - continuous ship unloaders.
- } equipment fitted with bucket wheels or bucket chains

For other equipment, such as

- excavators,
- scrapers,
- reclaimers with scraper chain,
- mixed tyre or caterpillar-mounted stackers and reclaimers,

the clauses in this International Standard as adapted to each type of apparatus are applicable.

### 2 Normative references

The following standards contain provisions which, through reference in this text, constitute provisions of this part of ISO 5049. At the time of publication, the editions indicated were valid. All standards are subject to revision, and parties to agreements based on this part of ISO 5049 are encouraged to investigate the possibility of applying the most recent editions of the standards indicated below. Members of IEC and ISO maintain registers of currently valid International Standards.

ISO 286-2:1988, *ISO system of limits and fits — Part 2: Tables of standard tolerance grades and limit deviations for holes and shafts.*

ISO 630:1980, *Structural steels.*

ISO 2148:1974, *Continuous handling equipment — Nomenclature.*

ISO 5048:1989, *Continuous mechanical handling equipment — Belt conveyors with carrying idlers — Calculation of operating power and tensile forces.*

### 3 Loads

Depending on their frequency, the loads are divided into three different load groups: main loads, additional loads and special loads.

- a) The main loads comprise all the permanent loads which occur when the equipment is used under normal operating conditions.

They include, among others:

- dead loads;
- material loads;
- incrustation;
- normal digging and lateral resistances;
- forces at the conveying elements for the material load;
- permanent dynamic effects;
- inclination of the machine;
- loads on the gangways, stairs and platforms.

- b) The additional loads are loads that can occur intermittently during operation of the equipment or when the equipment is not working; these loads can either replace certain main loads or be added to the main loads.

They include, among others:

- wind load for machines in operation;
- snow load;
- temperature load;
- abnormal digging and lateral resistance;
- resistances due to friction and travel;
- horizontal lateral forces during travelling;
- non-permanent dynamic effects.

- c) The special loads comprise the loads which should not occur during and outside the operation of the equipment but the occurrence of which is not to be excluded.

They include, among others:

- blocking of chutes;
- resting of the bucket wheel or the bucket ladder on the ground or face;
- blocking of travelling devices;
- lateral collision of the bucket wheel with the slope;
- wind load for machines not in operation;

- buffer effects;
- loads due to earthquakes.

In addition, it may be necessary to take into account the loads occurring on certain parts of the structure during assembly.

### 3.1 Main loads

#### 3.1.1 Dead loads

Dead loads are load forces of all fixed and movable construction parts, always present in operation, of mechanical and electrical plants as well as of the support structure.

#### 3.1.2 Material loads

The material load carried on conveyors and reclaimers is considered.

##### 3.1.2.1 Material load carried on the conveyors

These loads are determined from the design capacity (in cubic metres per hour).

##### 3.1.2.1.1 Units with no built-in reclaiming device

- a) Where the belt load is limited by automatic devices, the load on the conveyor will be assumed to be that which results from the capacity thus limited.
- b) Where there is no capacity limiter, the design capacity is that resulting from the maximum cross-sectional area of the conveyor multiplied by the conveying speed.

Unless otherwise specified in the contract, the cross-sectional area shall be determined assuming a surcharge angle  $\theta = 20^\circ$ .

The maximum sections of materials conveyed are calculated in accordance with ISO 5048.

- c) Where the design capacity resulting from a) or b) on the upstream units is lower than that of the downstream units, the downstream units may be deemed to have the same capacity as the upstream units.

##### 3.1.2.1.2 Units fitted with a reclaiming device (bucket wheel or bucket chain)

- a) Where there is no capacity limiter, the design capacity is 1,5 times the nominal filling capacity of

the buckets multiplied by the maximum number of discharges. In the case of bucket wheels, the factor 1,5, which takes into account the volumes which can be filled in addition to the buckets, can be replaced by taking into account the actual value of nominal and additional filling.

- b) Where there are automatic capacity limiters, the design capacity shall be the capacity thus limited.

Where the unit is intended to convey materials of different densities (for example, coal and ore), safety devices shall be provided to ensure that the calculated load will not be exceeded with the heavier material.

Dynamic load factor:

In order to take into account the dynamic loads which could be applied to the conveyor during transport, the load shall be multiplied by a factor of 1,1.

### 3.1.2.2 Load in the reclaiming devices

To take into account the weight of the material to be conveyed in the reclaiming devices, it is assumed that

- a) for bucket wheels
- one-quarter of all available buckets are 100 % full;
- b) for bucket chains
- one-third of all the buckets in contact with the face are one-third full;
  - one-third of all the buckets in contact with the face are two-thirds full;
  - all other buckets up to the sprocket are 100 % full.

### 3.1.2.3 Material in the hoppers

The weight of the material in the hoppers is obtained by multiplying the bulk density of the material by the volume (filled to the brim).

If the weight of the material is limited by reliable automatic controls, deviation from the value given in 3.1.2.2 is permissible.

### 3.1.3 Incrustation

The degree of incrustation (dirt accumulation) depends on the specific material and the operating conditions prevailing in each given case. The data which

follow shall be taken as guidance. The actual values can deviate towards either higher or lower values.

For storage yard appliances, the values are generally lower, while for other equipment (for example in mines) they shall be taken as minimum values.

Loads due to dirt accumulation shall be taken into account:

- a) on the conveying devices, 10 % of the material load calculated according to 3.1.2;
- b) for bucket wheels, the weight of a 5 cm thick layer of material on the centre of the bucket wheel, considered as a solid disc up to the cutting circle;
- c) for bucket chains, 10 % of the design material load calculated according to 3.1.2, uniformly distributed over the total length of the ladder.

### 3.1.4 Normal digging and lateral resistances

These forces shall be calculated as concentrated loads, i.e. on bucket wheels as acting at the most unfavourable point of the cutting circle, and on bucket chains as acting at a point one-third of the way along the part of the ladder in contact with the face.

#### 3.1.4.1 Normal digging resistance

The normal digging resistance acting tangentially to the wheel cutting circle or in the direction of the bucket chain (on digging units and, in general, on units for which the digging load is largely uncertain) is obtained from the rating of the drive motor, the efficiency of the transmission gear, the circumferential speed of the cutting edge and the power necessary to lift the material and (in the case of bucket chains) from the power necessary to move the bucket chain.

To calculate the lifting power, the figures indicated in 3.1.2.2 may be used.

For storage yard applications, the above method of calculation may be ignored if the digging resistance of the material is accurately known as a result of tests and if it is known for sure that this digging resistance will not be exceeded during normal operation.

#### 3.1.4.2 Normal lateral resistance

Unless otherwise specified, the normal lateral resistance can be assumed to be 0,3 times the value of the normal digging resistance.

### 3.1.5 Forces on the conveyor

Belt tensions, chain tensions, etc. shall be taken into consideration for the calculation as far as they have an effect on the structures.

### 3.1.6 Permanent dynamic effects

**3.1.6.1** In general, the dynamic effect of the digging resistances, the falling masses at the transfer points, the rotating parts of machinery, the vibrating feeders, etc. need only be considered as acting locally.

**3.1.6.2** The inertia forces due to acceleration and braking of moving structural parts shall be taken into account. These can be neglected for appliances working outdoors if the acceleration or deceleration is less than  $0,2 \text{ m/s}^2$ .

If possible, the drive motors and brakes shall be designed in such a way that the acceleration value of  $0,2 \text{ m/s}^2$  is not exceeded.

If the number of load cycles caused by inertia forces due to acceleration and braking is lower than  $2 \times 10^4$  during the life-time of the machine, the effects shall be considered as additional loads (see also 3.2.7).

### 3.1.7 Loads due to inclination of the machine

In the case of inclination of the working level, forces will be formed by breaking down the weight loads acting vertically and parallel to the plane of the working level. The slope loads shall be based on the maximum inclinations specified in the delivery contract and shall be increased by 20 % for the calculation.

### 3.1.8 Loads on the gangways, stairs and platforms

Stairs, platforms and gangways shall be constructed to bear 3 kN of concentrated load under the worst conditions, and the railings and guards to stand 0,3 kN of horizontal load.

When higher loads are to be supported temporarily by platforms, the latter shall be designed and sized accordingly.

## 3.2 Additional loads

### 3.2.1 Wind load for machines in operation

During handling, a wind speed of  $v_w = 20 \text{ m/s}$  ( $72 \text{ km/h}$ ) shall be assumed, unless otherwise speci-

fied because of local conditions. The aerodynamic pressure,  $q$ , in kilopascals<sup>1)</sup>, shall be calculated using the following generally applied formula:

$$q = \frac{v_w^2}{1\,600}$$

where

$v_w$  is the wind speed in metres per second.

The aerodynamic pressure during the handling operation is then

$$q = 0,25 \text{ kN/m}^2$$

Calculating wind action:

It shall be assumed that the wind can blow horizontally in all directions.

The effect of wind action on a structural element is a resultant force,  $P$ , in kilonewtons, the component of which resolved along the direction of the wind is given by the equation

$$P = A \times q \times c$$

where

$A$  is the area, in square metres, presented to the wind by the structural element, i.e. the projected area of the structural element on a plane perpendicular to the direction of the wind;

$q$  is the aerodynamic pressure, in kilonewtons per square metre;

$c$  is an aerodynamic coefficient taking into account the overpressures and underpressures on the various surfaces. It depends on the configuration of the structural elements; its values are given in table 1.

When a girder or part of a girder is protected from the wind by another girder, the wind force on this girder is determined by applying a reducing coefficient  $\eta$ . It is assumed that the protected part of the second girder is determined by the projection of the contour of the first girder on the second in the direction of the wind. The wind force on the unprotected parts of the second girder is calculated without the coefficient  $\eta$ .

1)  $1 \text{ kPa} = 1 \text{ kN/m}^2$



The value of this coefficient  $\eta$  will depend on  $h$  and  $b$  (see figure 1 and table 2) and on the ratio

$$\varphi = \frac{A}{A_e}$$

where

$A$  is the visible area (solid portion area);

$A_e$  is the enveloped area (solid portions + voids);

$h$  is the height of the girder;

$b$  is the distance between the surfaces facing each other.

When, for lattice girders, the ratio  $\varphi = A/A_e$  is higher than 0,6, the reducing coefficient is the same as for a solid girder.

**Table 1 — Values of the aerodynamic coefficient,  $c$**

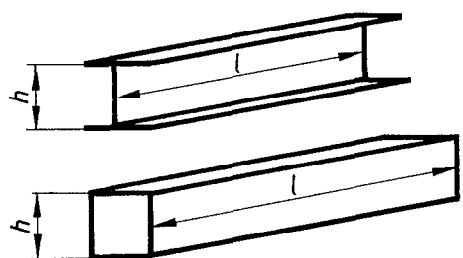
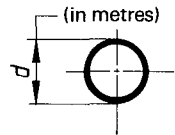
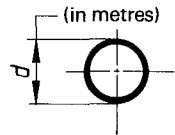
Type of girder		$c$
Lattice of rolled sections		1,6
Solid-web or box girders		for $l/h$ $\left\{ \begin{array}{l} 20 \\ 10 \\ 5 \\ 2 \end{array} \right.$ $\left. \begin{array}{l} 1,6 \\ 1,4 \\ 1,3 \\ 1,2 \end{array} \right.$
Members of circular section		$d\sqrt{100q} < 1$ 1,2
Tubular lattice		$d\sqrt{100q} > 1$ 0,7
$q$ (in kilonewtons per square metre)		

NOTE — Certain values of  $c$  can be lowered if wind tunnel tests show that the values contained in the table are too high.

**Table 2 — Values of reducing coefficient  $\eta$  as a function of  $\varphi = A/A_e$  and the ratio  $b/h$**

$\varphi = \frac{A}{A_e}$	0,1	0,2	0,3	0,4	0,5	0,6	0,8	1
$b/h = 0,5$	0,75	0,4	0,32	0,21	0,15	0,05	0,05	0,05
$b/h = 1$	0,92	0,75	0,59	0,43	0,25	0,1	0,1	0,1
$b/h = 2$	0,95	0,8	0,63	0,5	0,33	0,2	0,2	0,2
$b/h = 4$	1	0,88	0,76	0,66	0,55	0,45	0,45	0,45
$b/h = 5$	1	0,95	0,88	0,81	0,75	0,68	0,68	0,68

NOTE — These values are also represented by the curves in figure 2.

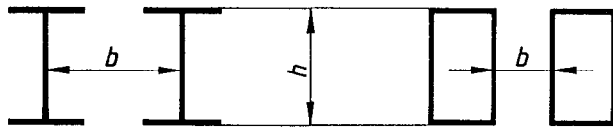

Figure 1 — Height  $h$  and width  $b$

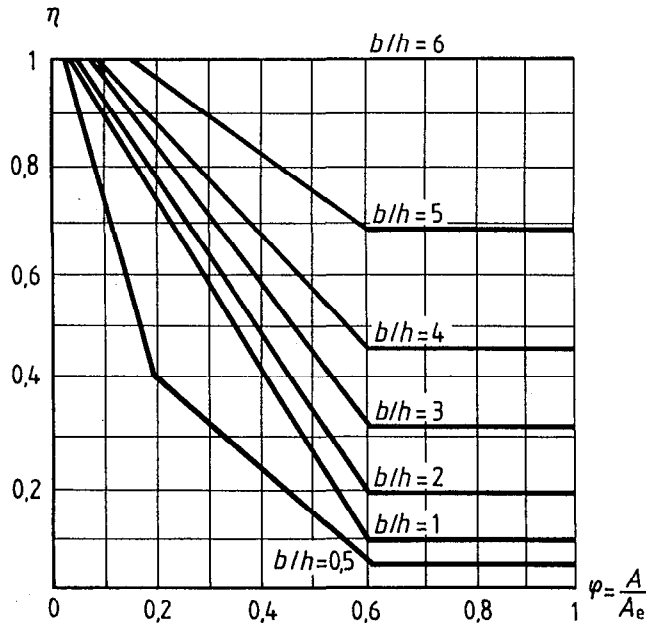

Figure 2 — Curves giving values of  $\eta$

**3.2.2 Snow and ice load**

The loads due to snow and ice have been considered by the load case 3.1.3 (incrustation). If the customer does not prescribe load values due to particular climatic conditions, snow and ice need not be included.

**3.2.3 Temperature**

Temperature effects need only be considered in special cases, for example when using materials with very different expansion coefficients within the same component.

**3.2.4 Abnormal digging resistance and abnormal lateral resistance**

The abnormal digging resistance acting tangentially to

the bucket wheel or in the direction of the bucket chain is calculated from the starting torque of the drive motor or from the cut-off torque of the built-in safety coupling, taking into account the more unfavourable of the two cases listed below:

a) if the wheel or chain is not loaded:

in this case, account is not taken of the power necessary to lift the material to be transported, and the load due to the starting torque of the motor is considered as a digging load;

b) if the wheel and chain are loaded according to 3.1.2.2:

in this case, the digging power results from the starting torque of the motor, reduced by the lifting power.

The abnormal lateral resistance is calculated as in 3.1.4.2, thereby considering a load of 0,3 times the abnormal digging resistance.

If appropriate, this load can be calculated from the working torque of an existing cut-out device at least equal to 1,1 times the sum of the torques due to the inclination of the machine (see 3.1.7) and to wind load for machines in operation (see 3.2.1).

**3.2.5 Resistances due to friction and travel**

a) Frictional resistances need only be calculated as long as they influence the sizes.

The friction coefficients shall be calculated as follows:

- for pivots and ball bearings:  $\mu = 0,10$
- for structural parts with sliding friction:  $\mu = 0,25$

b) For calculating the resistances to travel, the friction coefficients are as follows:

- on wheels of rail-mounted machines:  $\mu = 0,03$
- on wheels of crawler-mounted machines:  $\mu = 0,1$
- between crawler and ground:  $\mu = 0,60$

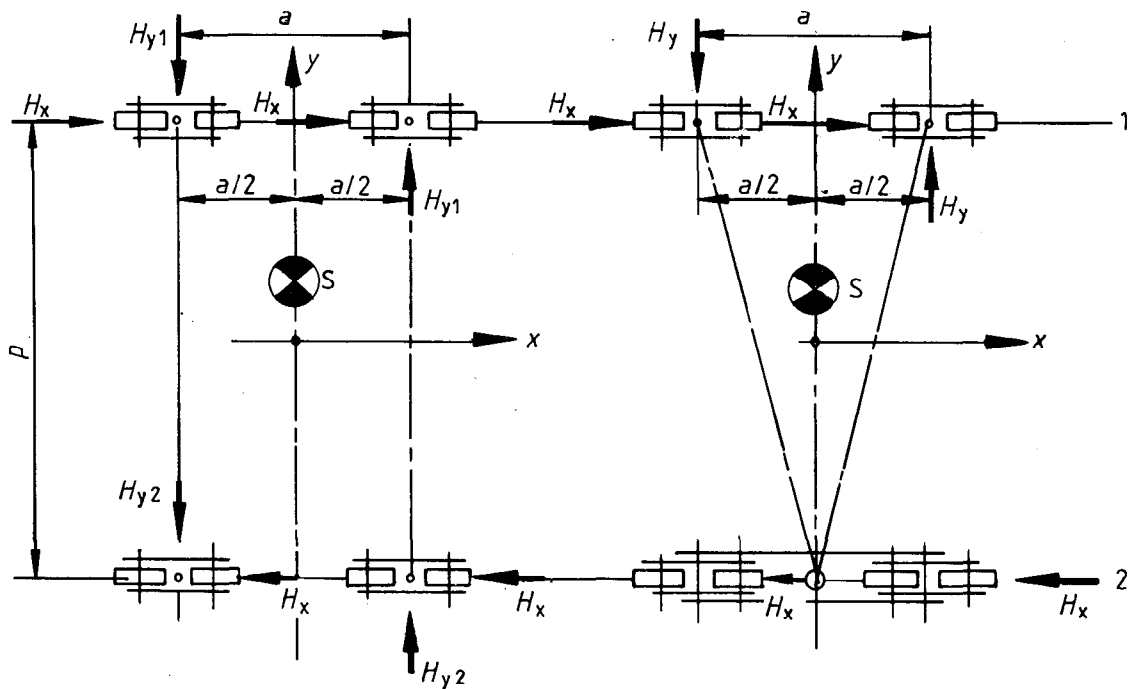

Figure 3 — Appliances on rails

**3.2.6 Reactions perpendicular to the rail due to movement of appliance**

In the case of appliances on rails which do not undergo any reaction perpendicular to the rail other than those reactions due to wind and forces of inertia, account shall be taken of the reactions resulting from the rolling movement of the unit taking a couple of force  $H_y$  directed perpendicularly to the rail as in figure 3.

The components of this couple are obtained by multiplying the vertical load exerted on the wheels or bogies by a coefficient  $\lambda$  which depends on the ratio of the rail gauge,  $p$ , to the wheel or bogie wheel base,  $a$ .

To calculate the couple  $H_y$ , take the centre of gravity  $S$  of the appliance on the  $y$ -axis in an unfavourable position in relation to sides 1 and 2.

if there are horizontal guiding wheels, the distance between the guiding wheels shall be taken as value  $a$ .

Figure 4 gives the values of  $\lambda$  as a function of the  $p/a$  ratio.

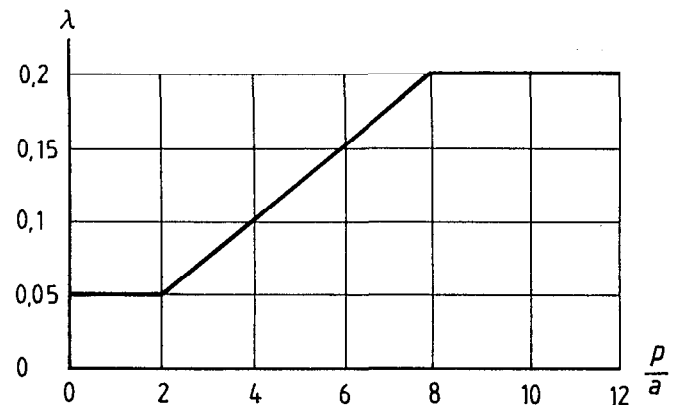

Figure 4 — Values of  $\lambda$

**3.2.7 Non-permanent dynamic effects**

The mass forces due to the acceleration and braking of moving structural parts occurring less than  $2 \times 10^4$  times during the lifetime of the appliance shall be checked as additional loads. They may be disregarded if their effect is less than that of the wind force during operation as per 3.2.1.

If the mass forces are such that they have to be taken into account, the wind effect can be disregarded.

### 3.3 Special loads

#### 3.3.1 Blockage of chutes

The weight of material due to a blockage shall be calculated using a load which is equivalent to the capacity of the chute in question, with due reference to the angle of repose. The material normally within the chute may be deducted. The actual bulk weight shall be taken for the calculation.

#### 3.3.2 Resting of the bucket wheel or the bucket ladder on the face

Where safety devices, for example slack rope safeguard for rope suspensions or pressure switches for hydraulic hoists, are installed which prevent the full weight of the bucket wheel or the bucket ladder from coming to rest, the allowable resting force shall be calculated as a special load at 1,1 times its value.

Where such safety devices are not provided, the special load shall be calculated with the full resting weight.

#### 3.3.3 Failure of safety devices as in 3.1.2.1

In the case of failure on the part of the automatic safety devices mentioned in 3.1.2.1 to limit the useful loads on the conveyors, the capacity can be calculated as follows:

- a) in the case of appliances without built-in reclaiming device, according to 3.1.2.1.1 b);
- b) in the case of appliances with built-in reclaiming device, according to 3.1.2.1.2 a).

For this purpose, account need not be taken of the dynamic factor 1,1.

#### 3.3.4 Locking of travelling devices

For rail-mounted equipment, it shall be taken into account that bogies may be blocked, for example by derailment or rail fracture. For the loads occurring under such conditions, the coefficient of friction between driven wheels and rails shall be taken as  $\mu = 0,25$  provided that the drive motors can generate sufficient power.

For equipment mounted on fixed rails, a wheel can be considered as blocked (i.e. unable to rotate but sliding on the rail).

For equipment mounted on movable rails, blocking of a trailing wheel or bogie shall be assumed as due to

derailment or rail fracture. The maximum drive effort of non-blocked wheels shall then be determined. It shall not exceed the friction-transmitted effort between wheels and rails.

#### 3.3.5 Lateral collision with the slope in the case of bucket wheel machines

The maximum lateral resistance in bumping against the slope is determined by the safety coupling in the slewing gear or the kinetic energy of the superstructure. This load shall be applied in accordance with 3.1.4. In calculating the lateral resistance from the kinetic energy, a theoretical braking distance of 30 cm and a constant braking deceleration shall be assumed.

#### 3.3.6 Wind load on non-operating machines

For this case, unless otherwise specified because of local conditions, the wind speeds and aerodynamic pressures given in table 3 shall be taken, with reference to the above-ground height of the structural element in question.

**Table 3 — Wind speeds and aerodynamic pressures**

Above-ground height of the structural element involved	Wind speed		Aerodynamic pressure $q$
	$v_w$		
m	m/s	km/h	kN/m <sup>2</sup>
2 to 20	36	130	0,8
20 to 100	42	150	1,1
above 100	46	165	1,3

For wind effect calculation, see 3.2.1.

#### 3.3.7 Buffer effects

For horizontal speeds below 0,5 m/s, no account shall be taken of buffer effects. For speeds in excess of 0,5 m/s, account shall be taken of the reaction of the structure to collision with a buffer, when buffering is not made impossible by special devices.

It shall be assumed that the buffers are capable of absorbing the kinetic energy of the machine with operating load up to the rated travelling speed,  $v_T$ , as a minimum.

The resulting loads on the structure shall be calculated in terms of the retardation imparted to the machine by the buffer in use.

### 3.3.8 Loads due to earthquakes

If the delivery contract includes data concerning the effects due to earthquakes, these loads shall be considered in the calculation as special loads.

### 3.3.9 Erection loads

In certain cases, it may be necessary to check some structural parts under dead loads in particular momentary situations during erection.

## 4 Load cases

The main, additional and special loads mentioned in clause 3 shall be combined in load cases I, II and III according to table 4.

Only loads which can occur simultaneously and which produce, with the dead weight, the greatest forces at the cutting points, shall be combined.

For case III the most unfavourable combination shall be retained.

**Table 4 — Load combinations**

Sub-clause	Type of load	Main loads	Main and additional loads	Main, additional and special loads									Erection load	
		I		II	III 1	III 2	III 3	III 4	III 5	III <sup>1)</sup> 6	III 7	III 8		III 9
3.1.1	Dead loads	x	x	x	x	x	x	x	x	x	x	x	x	x
3.1.2	Material loads on conveyors, reclaiming devices and hoppers	x	x	x	x	x	x	x	x	x	x	x	x	x
3.1.3	Incrustation	x	x	x	x	x	x	x	x	x	x	x	x	x
3.1.4	Normal digging and lateral resistances	x	x	x	x	x	x	x	x	x	x	x	x	x
3.1.5	Forces on the conveyor	x	x	x	x	x	x	x	x	x	x	x	x	x
3.1.6	Permanent dynamic effects	x	x	x	x	x	x	x	x	x	x	x	x	x
3.1.7	Loads due to inclination of machine	x	x	x	x	x	x	x	x	x	x	x	x	x
3.2.1	Wind load during operation <sup>2)</sup>		x	x	x	x	x	x	x	x	x	x	x	x
3.2.2	Snow and ice (possibly)													
3.2.3	Temperature (possibly)													
3.2.4	Abnormal digging and lateral resistances		x											
3.2.5	Resistances due to friction and travel		x											
3.2.6	Reactions perpendicular to the rail		x											
3.2.7	Non-permanent dynamic effects		x											
3.3.1	Blockage of chutes			x										
3.3.2	Bucket-wheel resting				x									
3.3.3	Failure of safety devices					x								
3.3.4	Locking of travelling device						x							
3.3.5	Lateral collision with the slope (bucket wheel)							x						
3.3.6	Wind load on non-operating machine								x					x
3.3.7	Buffer effects									x				
3.3.8	Loads due to earthquakes										x			
3.3.9	Erection loads (dead loads in particular situations)													x

1) The removal of abnormal digging resistances (see 3.2.4) shall be ensured, when necessary, by appropriate devices (locking device which prevents slewing of appliance when out of service due to wind force).

2) See 3.2.7.

## 5 Design of structural parts for general stress analysis

### 5.1 General

The stresses arising in the structural parts shall be determined for the three load combinations and a check shall be made to ensure that an adequate safety margin exists with respect to the critical stresses, considering the following:

- straining beyond the yield point or the permissible stress, respectively,
- straining beyond the permissible crippling or buckling stress, and, possibly,

— exceeding the permissible fatigue strength.

The cross-sections to be used in such analysis shall be the net sections for all parts which are subjected to tension (i.e. deducting the area of holes) and the cross-sections for all parts which are subjected to pressure (i.e. without deducting the area of holes); in the latter instance, holes are only included in the cross-section when they are filled by a rivet or bolt.

Conventional strength of materials calculation procedures shall be used to calculate the strength.

### 5.2 Characteristic values of materials

For structural steel members, the values in table 5 shall be used.

**Table 5 — Characteristic values of materials**

Material (ISO 630)		$R_{p0,2}$ , min.			$R_m$ N/mm <sup>2</sup>	$E$ N/mm <sup>2</sup>	$G$ N/mm <sup>2</sup>	$\alpha_t$ K <sup>-1</sup>
Grade	Quality	$e^1 \leq 16$ N/mm <sup>2</sup>	$16 < e \leq 40$ N/mm <sup>2</sup>	$40 < e \leq 63$ N/mm <sup>2</sup>				
Fe 360	A	235	225	215	360 to 460	$21 \times 10^4$	$8,1 \times 10^4$	$1,2 \times 10^{-5}$
	B	235	225	215				
	C	235	225	215				
	D	235	225	215				
Fe 430	A	275	265	255	430 to 530	$21 \times 10^4$	$8,1 \times 10^4$	$1,2 \times 10^{-5}$
	B	275	265	255				
	C	275	265	255				
	D	275	265	255				
Fe 510	B	$e^1 \leq 16$	$16 < e \leq 35$	$35 < e \leq 50$	490 to 630	$21 \times 10^4$	$8,1 \times 10^4$	$1,2 \times 10^{-5}$
		355	345	335				
	C	355	345	335				
	D	355	345	335				

1)  $e$  = thickness in millimetres

### 5.3 Calculation of allowable stresses with respect to the yield point

The stresses for load combination cases I, II and III calculated according to clause 4 shall be compared with the allowable stresses  $\sigma_a$  for these load combination cases.

These latter stresses are obtained by dividing the yield point  $R_{p0,2}$  by an appropriate safety coefficient.

The allowable stresses shall be as follows, for structural members subjected to tension or compression and to the extent they are not liable to buckling:

$$\text{Case I: } \sigma_a = \frac{R_{p0,2}}{1,5}$$

$$\text{Case II: } \sigma_a = \frac{R_{p0,2}}{1,33}$$

$$\text{Case III: } \sigma_a = \frac{R_{p0,2}}{1,2}$$

For structural members submitted to shear loads:

$$\tau_a = \frac{\sigma_a}{\sqrt{3}}$$

For combined loads, if a stress  $\sigma_x$ , a normal stress  $\sigma_y$  perpendicular to the latter and a shear stress  $\tau_{xy}$  occur simultaneously on a flat plate, the following condition shall be satisfied for the resultant combined stress  $\sigma_{cp}$ :

$$\sigma_{cp} = \sqrt{\sigma_x^2 + \sigma_y^2 - \sigma_x \sigma_y + 3 \tau_{xy}^2} \leq \sigma_a$$

The allowable stresses for the most current steels are summarized in table 6.

Other materials not shown in table 6 can be used when the mechanical properties, the chemical com-

position and, when applicable, the weldability of the material are guaranteed by the producer.

For high yield point steels  $R_{p0,2}/R_m > 0,7$ , the allowable stresses,  $\sigma_a$ , shall satisfy the following condition:

$$\sigma_a \leq \frac{R_{p0,2} + R_m}{\sigma_{E52} + \sigma_{R52}} \times \sigma_{a52}$$

where

$R_{p0,2}$  and  $R_m$  represent respectively the yield point and the ultimate stress of the steel in question;

$\sigma_{E52}$  and  $\sigma_{R52}$  represent respectively the yield point and the ultimate stress for Fe 510;

$\sigma_{a52}$  is the allowable stress for Fe 510 for the load case in question.

### 5.4 Checking of framework elements submitted to compression loads

In general, checking of framework elements submitted to compression loads and subject to column and beam buckling or to plate and shell buckling shall be undertaken using existing national rules. These should be applied carefully in relation to load cases I, II and III.

Checking of safety against plate and shell buckling shall be undertaken as shown in 5.4.1 to 5.4.3.

#### 5.4.1 Buckling of flat plates

The calculation method for the determination of the buckling stress,  $\sigma_{vki}$ , for the different normal stress distributions, for the shear stresses as well as for the different ratios for the two sides of the plates subjected to buckling, shall be left to the manufacturer, who is, however, required to state its origin.

**Table 6 — Allowable stresses**

Values in newtons per square millimetre  
(1 N/mm<sup>2</sup> = 1 MPa)

Structural steel	Fe 360			Fe 430			Fe 510		
	I	II	III	I	II	III	I	II	III
Load case									
Tension or compression <sup>1)</sup> , $\sigma_a$	160	180	200	180	210	230	240	270	300
Shear, $\tau_a$	93	104	116	104	121	131	139	157	174

1) When crippling of the compressed members is not possible.

### 5.4.2 Buckling of cylindrical circular shells

The buckling stress,  $\sigma_{ki}$ , of cylindrical circular shells (for example tubes) with transversal frames at a maximum spacing of  $12r$  shall be determined according to the following formula:

$$\sigma_{ki} = 0,2 \frac{E \times \delta}{r}$$

where

- $E$  is Young's modulus of the material studied;
- $\delta$  is the thickness of the wall;
- $r$  is the maximum radius measured at the middle of the wall thickness.

### 5.4.3 Safety factors (see table 7)

**Table 7 — Safety factor against buckling,  $\nu_B$**

Component	$\nu_B$		
	Load case I	Load case II	Load case III
Web plates	1,35	1,25	1,2
Flange plates	1,5	1,35	1,3
Cylindrical circular shells	1,7	1,5	1,4

The safety factor,  $\nu_B$ , against buckling of flat plates is given by the ratio

$$\nu_B = \frac{\sigma_{vki}}{\sigma_{cp}} \quad \text{or} \quad \nu_B = \frac{\sigma_{vk}}{\sigma_{cp}}$$

where

$\sigma_{cp} = \sqrt{\sigma^2 + 3\tau^2}$  is the comparative stress for the load case in question.

The safety factor,  $\nu_B$ , against buckling of cylindrical circular shells is given by the ratio

$$\nu_B = \frac{\sigma_{vki}}{\sigma_D} \quad \text{or} \quad \nu_B = \frac{\sigma_{vk}}{\sigma_D}$$

where  $\sigma_D$  is the maximum axial compression stress at the edge of the shell for the load case in question.

The buckling stress  $\sigma_{vk}$  is the reduced buckling stress  $\sigma_{vki}$  according to table 8.

For the walls of closed box girders which are subjected to bending loads around the two main axes, the values for the web plates are decisive.

For rectangular plates forming members of a bar under compression, the security regarding buckling,  $\nu_B$ , shall not be lower than the allowable security regarding buckling of the whole bar.



**Table 8 — Buckling stresses,  $\sigma_{vk}$**   
Values in newtons per square millimetre

$\sigma_{vki}$	$\sigma_{vk}$		
	Fe 360	Fe 430	Fe 510
157	vki	vki	vki
192	192	vki	vki
200	198	vki	vki
210	204	210	vki
220	208	217	vki
230	211	222	vki
240	214	226	vki
250	216	229	vki
260	218	231	vki
270	219	234	vki
280	221	236	vki
290	222	237	290
300	223	239	297
320	225	241	308
340	227	243	315
360	228	245	320
380	229	246	325
400	230	248	328
420	231	249	331
440	232	249	334
460	232	250	336
480	233	251	338
500	233	252	339
550	234	253	343
600	235	254	345
650	235	254	347
700	236	255	348
800	237	256	351
1 000	237	257	353
2 000	239	259	357
$\infty$	240	260	360

## 6 Design of joints for general stress checking

### 6.1 Welded joints

The most important types of weld joints and their qualities are described in table 9.

For the longitudinal loads, the allowable stresses in the structural members shall be applied according to table 6.

In the case of combined stresses in one plane, a comparative value shall be established for all the

types of welds and compared with the allowable stress  $\sigma_a$ , as follows:

$$\sigma_{wcp} = \sqrt{\bar{\sigma}_x^2 + \bar{\sigma}_y^2 - \bar{\sigma}_x \bar{\sigma}_y + 2 \tau^2} \leq \sigma_a$$







where

$$\bar{\sigma}_x = \frac{\sigma_a}{\sigma_{w\text{all}}} \times \sigma_x$$

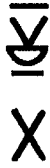
$$\bar{\sigma}_y = \frac{\sigma_a}{\sigma_{w\text{all}}} \times \sigma_y$$

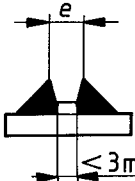
The weld joint shall have at least the tensile strength and the yield point of the steel of the welded structural members. (See table 10.)

Table 9 — Main types of weld joints

Type of weld	Weld quality	Weld preparation	Example of symbols <sup>1)</sup>	Test to determine acceptable weld	
				Test methods	Symbols
Butt weld in the thickness of assembled elements	Special quality	Gauge root of weld-back before sealing run execution, without end craters; grind sealing flush with the plate; grind parallel to the direction of the external forces		Non-destructive test of the seam over its full length, for example X-rays	P 100
	Standard quality	Gauge root of weld-back before sealing run execution, without end craters		As for the special quality, but solely: — under tensile stress (see table 10), with $\sigma_{max}$ calculated $\geq 0,8 \sigma_a$ $\sigma_a$ as a function of $\kappa$ (see 7.2.2)	P 100
				Non-destructive testing on a spot check basis over at least 10 % of the seam length, for example X-rays	P
Double bevel butt weld in the angle formed by the two components with a groove in one of the assembled elements at the root	Special quality	Gauge root of weld-back. Complete penetration weld. Notchless weld edges, grind if necessary		Non-destructive test of the plate under tensile stress perpendicularly to its surface to detect laminations (for example using ultrasonic testing)	D
	Standard quality	Width of unwelded portion at root of joint is less than 3 mm or less than 0,2 times the thickness of the welded portion. The lowest is determinant 			
Fillet weld in the angle formed by the assembled components	Special quality	Notchless weld edges; grind if necessary			
	Standard quality				

1) Weld symbols are taken from ISO 2553; see also ISO 5817 and ISO 6520.

**Table 10 — Allowable stresses  $\sigma_w$  in welded joints**

Values in newtons per square millimetre

Types of welding	Fe 360			Fe 430			Fe 510		
	case I	case II	case III	case I	case II	case III	case I	case II	case III
<b>Tensile stress in the case of transversal stressing</b>									
1 Butt weld, special or current quality K-weld, special quality	160	180	200	173	195	216	240	270	300
2 K-weld, current quality	140	160	180	152	173	195	210	240	270
3 Fillet weld, special or current quality	113	127	141	122	138	153	170	191	212
<b>Compressive stress in the case of transversal stressing</b>									
1 Butt weld, special or current quality K-weld, special or current quality	160	180	200	173	195	216	240	270	300
2 Fillet weld, special or current quality	130	145	163	141	157	176	195	220	244
<b>Shearing stress</b>									
All types of welds	113	127	141	123	138	153	170	191	212

## 6.2 Bolted and riveted joints

### 6.2.1 Fitted bolts

The allowable stresses specified in table 11 presuppose bolts whose shanks bear against the full length of the hole.

The holes shall be drilled and reamed. The tolerance in the hole shall be as follows:

- in the case of variable load always in the same direction ( $\kappa \geq 0$ ): ISO H11/h11<sup>2)</sup> gauge;
- in the case of alternating load ( $\kappa < 0$ ): ISO H11/k6 gauge.

### 6.2.2 Non-fitted bolts (forged black bolts)

Bolts of this type are tolerated only for secondary joints of members subjected to light load. They are not tolerated for joints subjected to fatigue.

### 6.2.3 Rivets

The rivet holes shall be drilled and reamed.

The rivets shall not be subjected to tensile load.

2) See ISO 286-2.

Table 11 — Allowable stresses for bolts and rivets

Kind of fasteners	Type	Steel grade or strength class		Load case	Allowable shear stress		Allowable diametral pressure		Allowable tensile stress
					$\tau_s$	$\sigma_L$	$\sigma_z$		
					N/mm <sup>2</sup>		N/mm <sup>2</sup>		N/mm <sup>2</sup>
Fitted bolts	Pure shear	4.6	ISO	I	0,6 $\sigma_a$	96	1,3 $\sigma_a$	210	100
				II		108		240	113
				III		120		270	125
		5.6	ISO	I		144		315	150
				II		162		360	170
				III		180		405	188
	Multiple shear	4.6	ISO	I	0,8 $\sigma_a$	128	1,75 $\sigma_a$	280	100
				II		144		320	113
				III		160		360	125
		5.6	ISO	I		192		420	150
				II		216		480	170
				III		240		540	188
Non-fitted bolts	—	4.6	ISO	I	0,5 $\sigma_a$	80	$\sigma_a$	160	100
				II		90		180	113
				III		(100)		(200)	125
	—	5.6	ISO	I		80		160	150
				II		90		180	170
				III		(100)		(200)	188
Rivets	Pure shear	A 34	—	I	0,6 $\sigma_a$	96	1,2 $\sigma_a$	210	—
				II		108		240	—
				III		120		270	—
		A 44	—	I		144		315	—
				II		162		360	—
				III		180		405	—
	Multiple shear	A 34	—	I	0,8 $\sigma_a$	128	1,75 $\sigma_a$	280	—
				II		144		320	—
				III		160		360	—
		A 44	—	I		192		420	—
				II		216		480	—
				III		240		540	—

### 6.3 Joints using high-strength friction-grip (HSFG) bolts with controlled tightening

This type of bolted joint offers the best guarantee against loosening; it is especially recommended for the joining of members subjected to dynamic loads.

#### 6.3.1 Forces parallel to the joint plane (symbol $T$ )

These forces are transmitted by friction to the mating surfaces after tightening.

The transmissible force of a bolt,  $T_a$ , is equal to

$$T_a = \frac{F \times \mu \times n}{v_T}$$

where

- $F$  is the tensile force after tightening;
- $\mu$  is the coefficient of friction of the mating surfaces;
- $n$  is the number of friction surfaces;
- $v_T$  is the slipping safety.

The tensile force after tightening is calculated on the basis of the permissible stress of the bolt material.

The allowable stress is:

— for a normal case:  $\sigma_F = 0,7R_{p0,2}$

(This determination takes into account the additional stresses when the bolt is tightened.)

— for an exceptional case:  $\sigma_F = 0,8R_{p0,2}$

(In this instance, the danger of stripping when the bolt is tightened shall be taken into account.)

The tensile forces after tightening shall be guaranteed by methods allowing the forces produced to be checked (tightening by means of a torque wrench or according to the nut tapping method).

The minimum condition consists in this case of cleaning the mating surfaces to remove all traces of paint and oil and in eliminating rust with a wire brush.

##### 6.3.1.1 Coefficients of friction

The coefficients of friction,  $\mu$ , are given in table 12.

Table 12 — Coefficients of friction,  $\mu$

Metal of the joints (ISO 630)	Simply prepared surfaces (removal of paint and oil and removal of rust by brushing)	Specially treated surfaces (flaming, sand blasting, shot blasting)
Fe 360	0,3	0,5
Fe 430	0,3	0,5
Fe 510	0,3	0,55

#### 6.3.1.2 Safety coefficients regarding slipping

Allowable safety coefficients regarding slipping are given in table 13.

Table 13 — Slipping safety

Load case	$v_T$
I	1,4
II	1,25
III	1,1

High-strength friction-grip bolt nuts shall be supported by washers which shall have a hardness of at least the same degree as that of the nut material. Intermediate spring washers shall not be used. The bolts need not be specially secured.

#### 6.3.1.3 Tightening torques and transmissible loads

See table 14 for values of  $T_a$  in the joint plane per HSFGBolt and per friction plane.

Bolt metal: ISO strength class 10.9

$$R_m = 1\,000 \text{ N/mm}^2 \text{ to } 1\,200 \text{ N/mm}^2$$

$$R_{p0,2} = 900 \text{ N/mm}^2$$

$$\sigma_F = 0,7R_{p0,2} \text{ (normal case)}$$

For a bolt with a yield point  $R'_{p0,2}$ , the values of the forces and torques of table 14 shall be multiplied by the ratio

$$R'_{p0,2}/900$$

Table 14 — Transmissible loads as a function of tightening torques

Bolt diameter <i>d</i> mm	Strength section <i>A<sub>s</sub></i> mm <sup>2</sup>	Tightening strength <i>F</i> kN	Applied torque <i>M<sub>a</sub></i> N·m	Simply prepared surfaces			Specially treated surfaces					
				<i>μ</i> = 0,3			<i>μ</i> = 0,5			<i>μ</i> = 0,55		
				Fe 360	Fe 430	Fe 510	Fe 360		Fe 430	Fe 510		
				case I	case II	case III	case I	case II	case III	case I	case II	case III
<i>T<sub>a</sub></i> kN	<i>T<sub>a</sub></i> kN	<i>T<sub>a</sub></i> kN	<i>T<sub>a</sub></i> kN	<i>T<sub>a</sub></i> kN	<i>T<sub>a</sub></i> kN	<i>T<sub>a</sub></i> kN	<i>T<sub>a</sub></i> kN	<i>T<sub>a</sub></i> kN	<i>T<sub>a</sub></i> kN			
10	58	36,6	72	7,8	8,8	10	13,1	14,6	16,6	14,4	16,1	18,3
12	84,3	53,3	126	11,4	12,8	14,5	19,1	21,4	24,2	21	23,5	26,7
14	115	72,6	200	15,5	17,4	19,7	25,9	29	33	28,5	31,9	36,3
16	157	99	310	21,2	23,8	27,5	35,4	39,6	45	38,9	43,6	49,5
18	192	121,5	430	26	29,2	33,1	43,4	48,7	55,2	47,9	53,5	60,9
20	245	155	610	33,2	37,2	42,2	55,4	62	70,5	61	68,2	77,5
22	303	192	830	41,1	46,1	52,2	68,5	76,8	87,1	75,5	84,5	96
24	353	222	1 050	47,5	53,2	60,4	79,2	88,7	100,8	87,2	97,5	111
27	459	290	1 540	62,1	69,6	78	103,5	116	132	114	127,5	145

When precautions are taken against thread stripping ( $\sigma_F = 0,8R_{p0,2}$ ), these values shall be multiplied by 1,14.

Bolts pre-tensioned with such loads shall not be additionally subject to tensile stress.

### 6.3.2 Forces perpendicular to the joint plane (symbol *N*)

High-strength friction-grip bolts can simultaneously transmit a tensile force *N*.

For the force transmitted by friction, it is then necessary to introduce the reduced value

$$T_a = \frac{(F - N_a) \times \mu \times n}{v_T}$$

The additional tensile force increases the bolt stress after tightening by a certain sum which depends on the elasticity of the bolt and of the compressed members. This relationship can be taken into account by the "coefficient of elongation",  $\phi$ , which depends, for solid steel plates and for the type of bolt used in

metal construction, on the length of tightening,  $l_g$ , and the diameter of the bolt, *d*.

For the normal case where the bolt is pre-tightened with

$$\sigma_F = 0,7R_{p0,2}$$

the allowable additional tensile force  $N_a$  can be calculated from the following formula:

$$N_a = \frac{0,12R_{p0,2} \times F_s}{v_a \times \phi}$$

where

$R_{p0,2}$  is the yield point of the bolt metal;

$v_a$  is the safety coefficient for the load cases ( $v_a$  I = 1,5;  $v_a$  II = 1,33;  $v_a$  III = 1,2);

$\phi$  is the coefficient of elongation on the basis of the ratio  $l_g/d$  according to table 15;

$A_s$  is the stress section of the bolt.

Table 16 gives the permissible tensile forces  $N_a$  for the most common bolt diameters and tightening lengths.

Table 15 — Coefficient of elongation,  $\phi$ 

$l_g/d$ <sup>1)</sup>	0,5	1	1,5	2	2,5	3	3,5	4	4,5	5	5,5	6	6,5	7	7,5
$\phi$	0,43	0,42	0,4	0,38	0,36	0,33	0,32	0,3	0,29	0,27	0,26	0,25	0,24	0,22	0,21

1)  $l_g$  is the length of tightening;  $d$  is the diameter of the bolt.

Table 16 — Allowable tensile forces for bolts after tightening

Tightening length  $l_g$  mm	$d = 16$ mm $F = 99$ kN			$d = 20$ mm $F = 155$ kN			$d = 24$ mm $F = 222$ kN		
	load case			load case			load case		
	I kN	II kN	III kN	I kN	II kN	III kN	I kN	II kN	III kN
10	26,2	29,8	32,8	—	—	—	—	—	—
16	27	30,4	33,6	41,6	46,9	52	—	—	—
22	27,7	31,2	34,4	42,7	48	53,3	60,5	68,1	75,6
28	29,2	32,5	35,8	44,2	49,7	55,3	62	69,8	77,5
34	30,4	34	37,6	45,4	51	56,8	63,5	71,5	79,5
40	31,5	35,5	39,2	46,6	52,4	58,2	65	73,3	81,6
46	33	37,6	41,5	47,9	53,8	59,8	66,4	74,7	83
52	34,2	38,8	42,8	49,8	56,1	62,3	67,4	76	84,4
58	35,5	40	44,1	52	58,5	65	69	77,8	86,5
64	37,8	42,5	47	53,7	60,3	67	72	81	90
70	39,2	44,2	48,6	55,4	62,2	69	74,8	84	93,5
76	40,6	45,8	50,4	57,1	64,2	71,2	77	86,7	96,5
82	42	47,4	52,3	59	66,3	73,8	79,4	89,4	99,5
88	43,7	49,2	54,3	61	68,6	76,3	82	92,2	102,5
94	45,5	51,2	56,5	63,3	71	79	83,3	94	104
100	46,5	52,2	57,8	65,6	73,7	82	84,8	95,5	106

NOTE — Bolt metal: ISO strength class 10.9:

$$R_m = 1\,000 \text{ N/mm}^2 \text{ to } 1\,200 \text{ N/mm}^2$$

$$R_{p0,2} = 900 \text{ N/mm}^2$$

Tightening:  $\sigma_F = 0,7R_{p0,2}$  (normal case)

## 6.4 Cables

6.4.1 The following types of cables are considered:

- guy and stay cables, which do not pass over sheaves and drums and have no sheaves or pulleys passing over them;
- winch cables, which run over sheaves or drums and require replacement in the event of wear.

6.4.2 The safety of the cables indicated in 6.4.1 shall be ensured against the breaking stress for the load case II forces (main and additional loads), in accordance with table 17.

Table 17 — Cable safety

Type of cable		Safety factors
Guy and stay cables		3
Winch cables	One-cable system	6
	Double-cable system in the normal case	6
	Double-cable system after failure of one cable	3

## 7 Calculation of allowable fatigue strength for structural members and for joints

### 7.1 General

Metal fatigue (failure due to fatigue) occurs when a structural member is subjected to frequently repeated surging or alternating loads.

For structural members and joints, the fatigue strength shall be checked for the load case I forces (main loads) when main loads occur which are likely to noticeably modify their value, namely by more than  $2 \times 10^4$  times in the course of the lifetime of the appliance.

Below  $2 \times 10^4$  load cycles, fatigue strength checking is not required.

All static loads which may occur to various extents, for example incrustation, shall be calculated with that value which produces the highest tensile stress.

### 7.2 Allowable stress, $\sigma_D$

The allowable stress is that stress for which there is no risk of failure after a certain number of repetition cycles. It depends upon the factors described in 7.2.1 to 7.2.4.

#### 7.2.1 Frequency of loads

The frequency of loads is the working period of an appliance during its lifetime and the repetition cycles expected in the course of this period from the various structural members and joints.

It is assumed that the appliances listed in clause 1 are subjected to regular intensive operation. On the basis of their repetition cycle number, three classes of structural members shall be distinguished.

Class A: Structural members with repetition cycles between  $2 \times 10^4$  and  $2 \times 10^5$ .

Class B: Structural members with repetition cycles between  $2 \times 10^5$  and  $6 \times 10^5$ .

NOTE 1 This class comprises the majority of the structural members subjected to fatigue mentioned in clause 1.

Class C: Structural members with repetition cycles more than  $6 \times 10^5$ .

#### 7.2.2 Ultimate stress ratio

$$\kappa = \frac{\sigma_{\min}}{\sigma_{\max}} \quad \text{OR} \quad \kappa = \frac{\tau_{\min}}{\tau_{\max}}$$

This is the ratio of the lowest ultimate stress ( $\sigma_{\min}$  or  $\tau_{\min}$ ) to the highest ultimate stress according to its sum ( $\sigma_{\max}$  or  $\tau_{\max}$ ). It varies as a function of the ultimate stress sign, in the surging region from + 1 to 0 and in the alternating region from 0 to - 1.

#### 7.2.3 Stress spectrum

This is the frequency which can be reached by a given stress according to the operating conditions. It is assumed that the ultimate stress  $\sigma_{\max}$  occurs almost always for the repetition cycles on which the lifetime of the appliance is based.

#### 7.2.4 Construction case

The notching effect on structural members and joints has an adverse influence on the fatigue strength. To take the notching effect into account, the types of construction and the joints are classified into eight construction cases listed in table 18.



### 7.3 Characteristic curves for allowable fatigue strength

For the repetition cycle classes A, B and C, the allowable fatigue strengths are given in the following tables:

Tables 19 to 21: Curves for tension and compression stresses of the eight construction cases in the parent metal and the weld joints.









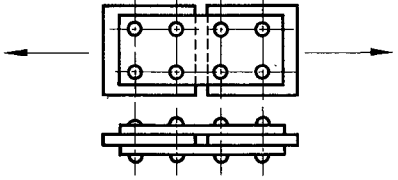
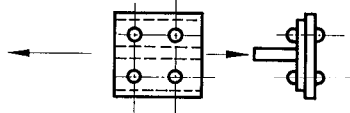
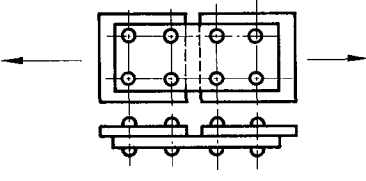

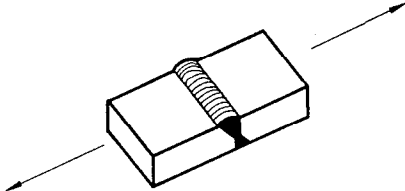
Tables 22 to 24: Characteristic curves for the shear stresses in the parent metal and in the weld joints.

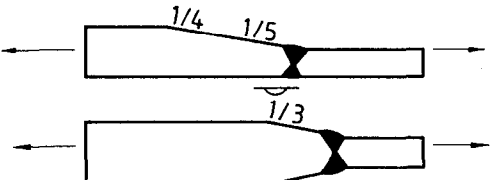
Tables 25 to 30: Characteristic curves for the shear and caulking stresses for fitted bolts and for rivets.

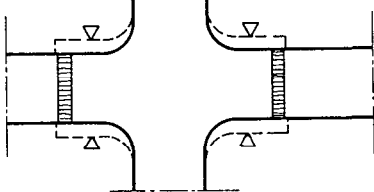

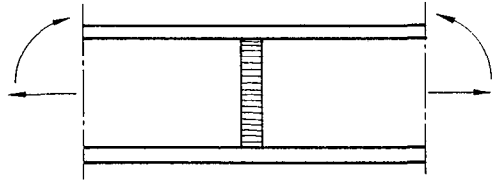

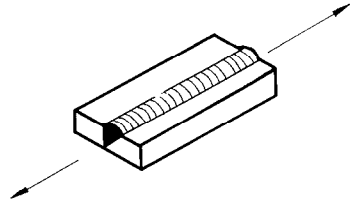
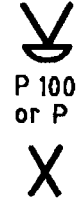
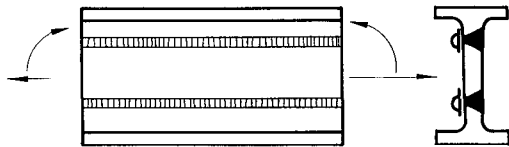



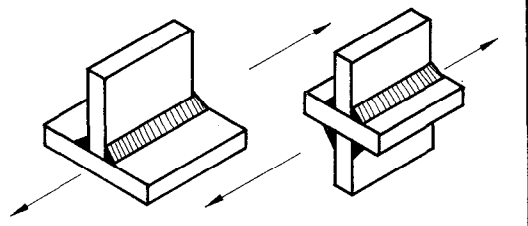
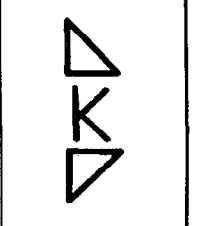
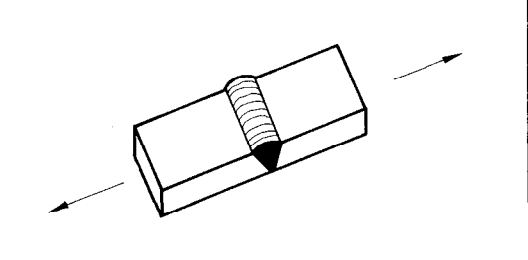
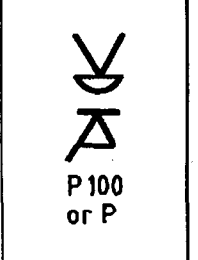
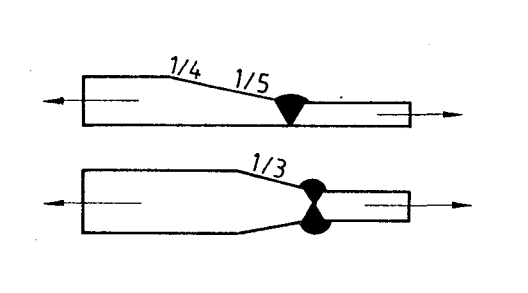
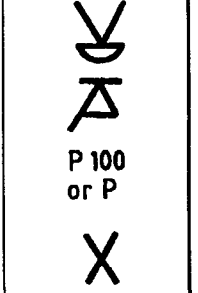
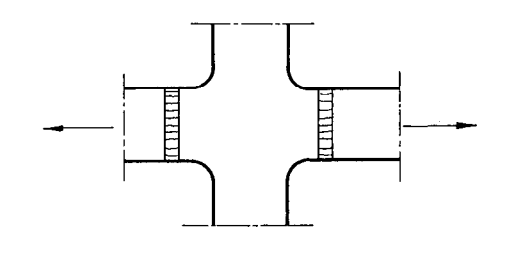
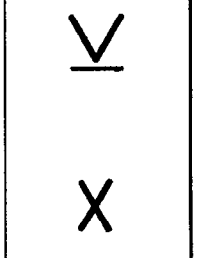
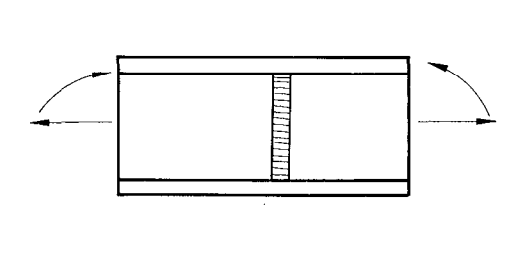
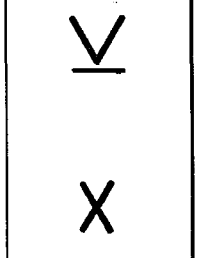
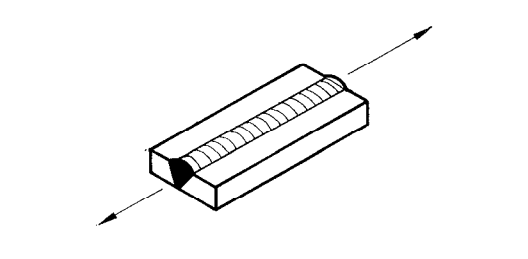
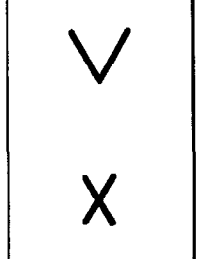

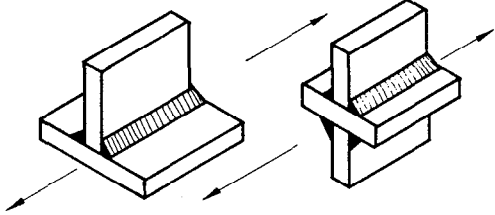
The high-strength friction-grip bolts conforming to 6.3 do not require checking for fatigue strength.

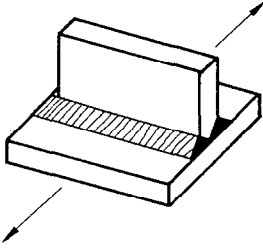
**Table 18 — Classified examples of joints**

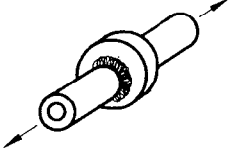



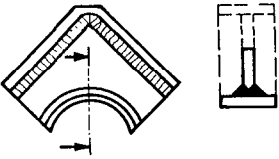



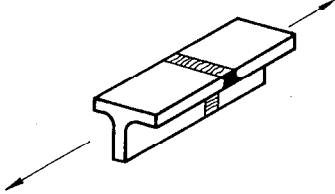
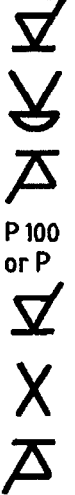
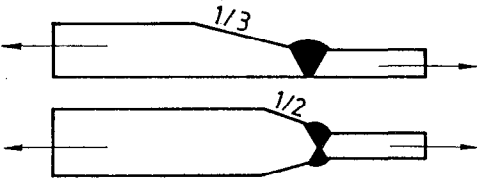
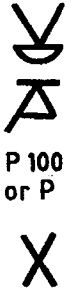
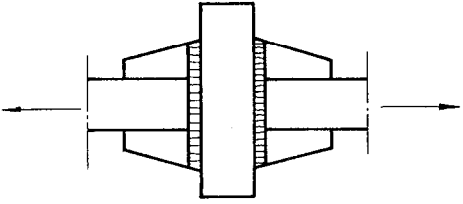
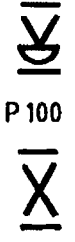
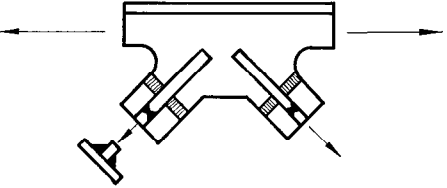
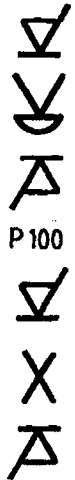

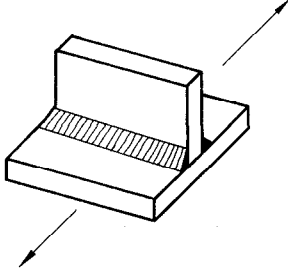

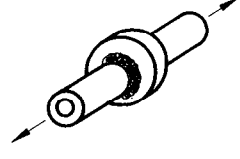
No.	Description and symbolization of the main cases	Symbol <sup>1)</sup>
<b>Case W<sub>0</sub></b>		
<b>W 01</b>	Non-perforated elements with normal surface finish when there are no notch effects or if they are taken into consideration in stress research. The thermal cutting shall only be carried out mechanically with high surface finish requirements.	—
<b>Case W<sub>1</sub></b>		
<b>W 11</b>	Thermal mechanically cut elements with a lower surface finish than for W 01. In the case of hand-cutting, this quality of cut can only be obtained with great care.	—
<b>W 12</b>	Perforated elements comprising also rivets and bolts. In the case of stresses on the rivets and bolts up to 20 % of the allowable value. In the case of stresses on HR bolts up to 100 % of the allowable value.	—
<b>Case W<sub>2</sub></b>		
<b>W 21</b>	Butt strap perforated for assembly, by rivets or bolts submitted to a double-shear stress.	
<b>W 22</b>	Shoe plate perforated for assembly, by rivets or bolts, submitted to a single-shear stress, for parts resting on a bearing surface or guided.	
<b>W 23</b>	Shoe plate perforated for assembly by rivets or bolts, submitted to a single-shear stress for non-bearing parts, with eccentric loads.	

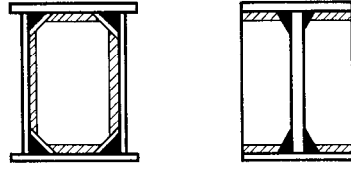

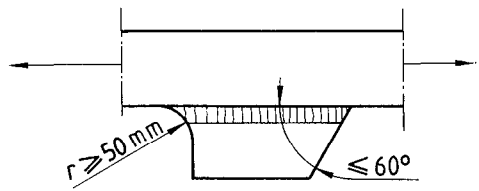

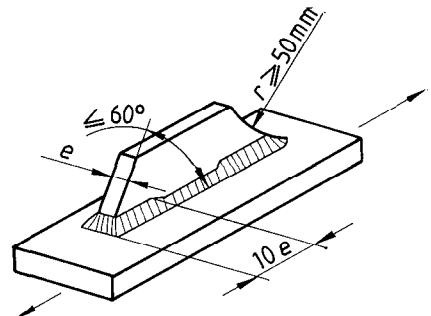

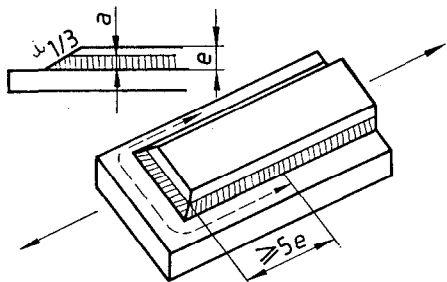



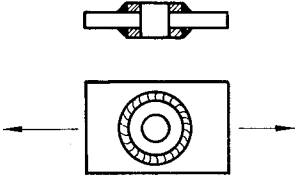

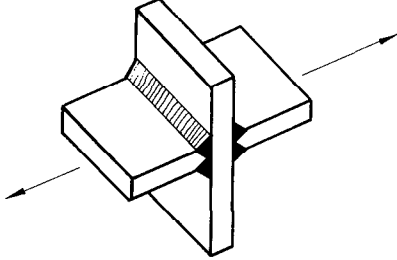
No.	Description and symbolization of the main cases	Symbol <sup>1)</sup>
<b>Case K<sub>0</sub> : Slight stress concentration</b>		
011	<p>Elements connected by single or double V butt weld (special quality) perpendicular to the stress direction, flush finished in the direction of the external forces.</p> 	 P 100
012	<p>Parts with different thicknesses connected by single or double V butt weld (special quality) perpendicular to the stress direction:</p> <ul style="list-style-type: none"> <li>— asymmetrical connecting slope: 1/5 to 1/4 or</li> <li>— symmetrical connecting slope: 1/3</li> </ul> 	 P 100
013	<p>Gusset fixed by single or double V butt weld (special quality) perpendicular to the stress direction.</p> 	 P 100
014	<p>Single or double V butt weld (special quality) of web transverse joint.</p> 	 P 100
021	<p>Elements connected by single or double V butt weld carried out parallel to the stress direction.</p> 	 P 100 or P X
022	<p>Single or double V butt weld between I-section flange and web.</p> 	 P 100 or P X

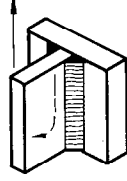

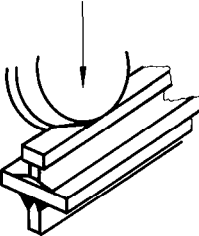

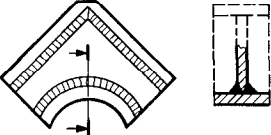

No.	Description and symbolization of the main cases	Symbol <sup>(1)</sup>
<b>Case K<sub>0</sub> : Slight stress concentration (concluded)</b>		
023	Elements connected by double bevel butt weld with double fillet weld carried out parallel to the stress direction.	 
<b>Case K<sub>1</sub> : Moderate stress concentration</b>		
111	Elements connected by single or double V butt weld perpendicular to the stress direction.	 
112	Parts of different thicknesses connected by single or double V butt weld perpendicular to the stress direction: — asymmetrical connecting slope: 1/5 to 1/4 or — symmetrical connecting slope: 1/3	 
113	Gusset fixed by single or double V butt weld perpendicular to the stress direction.	 
114	Single or double V butt weld of web transverse joint.	 
121	Elements connected by single or double V butt weld parallel to the stress direction.	 

No.	Description and symbolization of the main cases	Symbol <sup>1)</sup>
<b>Case <math>K_1</math> : Moderate stress concentration (concluded)</b>		
123	<p>Elements connected by fillet weld parallel to the stress direction.</p> 	
131	<p>Continuous main element on which the parts perpendicular to the stress direction are fixed by double bevel continuous weld (special quality).</p> 	
132	<p>Continuous element on which discs perpendicular to the stress direction are fixed by double bevel continuous weld (special quality).</p> 	
133	<p>Compressed flanges and webs fixed by fillet weld (special quality) to transverse web or stiffeners, with corners cut off. The classification in the case of construction only applies to the fillet weld area.</p> 	
154	<p>Double bevel continuous weld (special quality) connecting the web to the curved flange.</p> 	

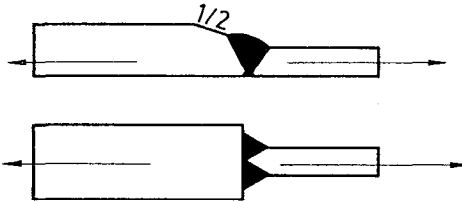
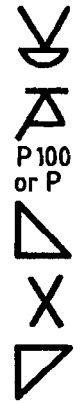
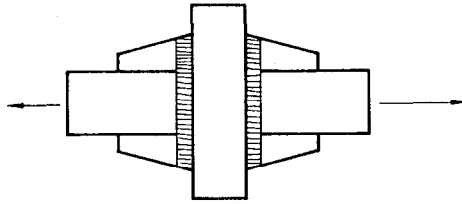
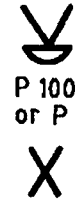
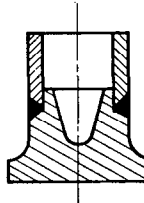

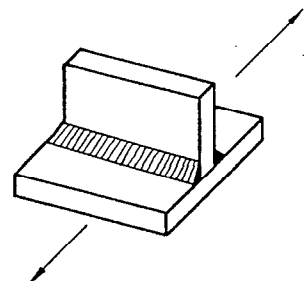

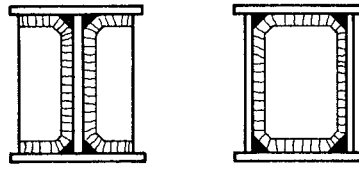





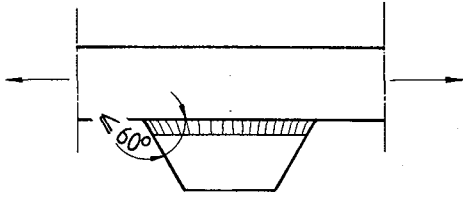

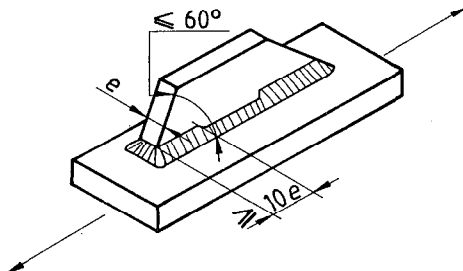
No.	Description and symbolization of the main cases	Symbol <sup>(1)</sup>
<b>Case K<sub>2</sub> : Medium stress concentration</b>		
<p><b>211</b></p>	<p>Merchant sections or bars connected by single or double V butt weld (special quality) perpendicular to the stress direction.</p> 	
<p><b>212</b></p> <ul style="list-style-type: none"> <li>— asymmetrical connecting slope: 1/3 or</li> <li>— symmetrical connecting slope: 1/2</li> </ul>		
<p><b>213</b></p>	<p>Butt weld seam (special quality) and continuous element, both perpendicular to the stress direction where the flats cross, with welded auxiliary gussets. The ends of the seams are ground, thereby avoiding the forming of notches.</p> 	
<p><b>214</b></p>	<p>Parts connected to a gusset by single or double V butt weld (special quality) perpendicular to the stress direction.</p> 	

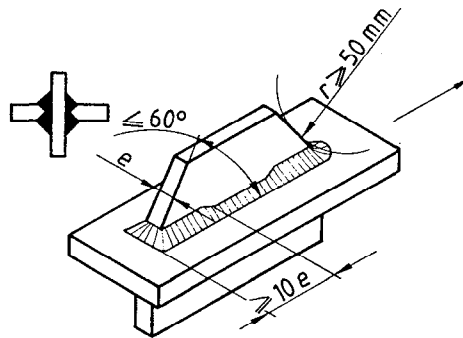

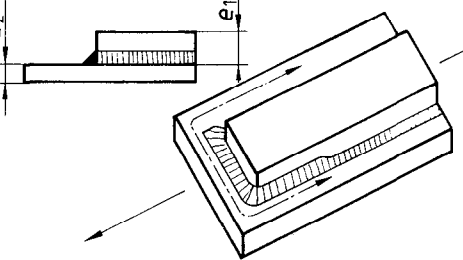

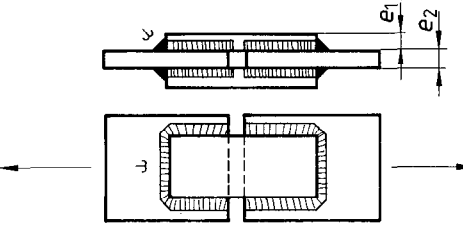

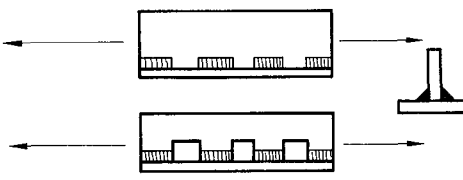



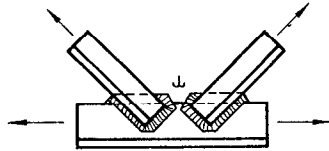

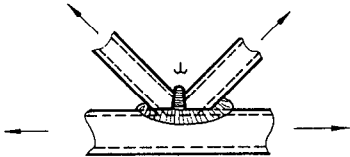
No.	Description and symbolization of the main cases	Symbol <sup>1)</sup>
<b>Case K<sub>2</sub> : Medium stress concentration (continued)</b>		
231	<p>Continuous element on which the parts are fixed by continuous double fillet weld (special quality) perpendicular to the stress direction.</p> 	
232	<p>Continuous element on which discs are fixed by double fillet weld (special quality) perpendicular to the stress direction.</p> 	
233	<p>Flanges and webs fixed by double fillet weld (special quality) to the transverse web and the stiffeners, with corners cut off. The classification in the case of construction only applies to the fillet weld area.</p> 	
241	<p>Continuous element at the edges of which parts parallel to the stress direction are fixed by single or double V butt weld (special quality). These parts finish with chamfers or fillets. The ends of the seams are ground, thereby avoiding forming of notches.</p> 	 
242	<p>Continuous element on which parts ending in chamfers or fillets are welded parallel to the stress direction. These seam ends are carried out in the area <math>10 e</math> by double bevel continuous weld (special quality).</p> 	 
244	<p>Continuous element on which a flange chamfered <math>1/3</math> is welded. The end of the seam is carried out in the area characterized by fillet weld (special quality) with <math>a = 0,5 e</math>.</p> 	

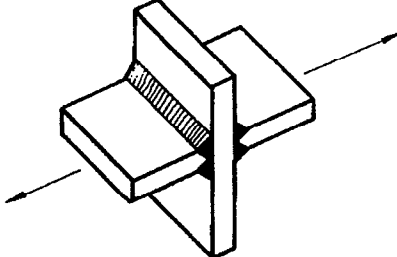

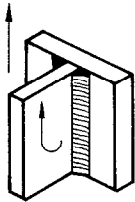

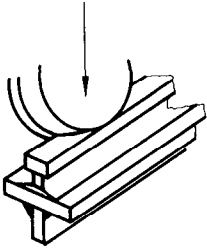

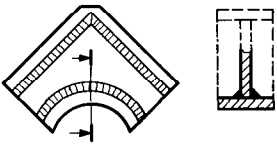



No.	Description and symbolization of the main cases	Symbol <sup>1)</sup>
<b>Case K<sub>2</sub> : Medium stress concentration (concluded)</b>		
245	<p>Continuous element on which hubs are fixed by fillet weld (special quality).</p> 	
251	<p>Double bevel continuous weld (special quality) perpendicular to the stress direction between parts crossing each other (cross joint).</p> 	
252	<p>Double bevel continuous weld (special quality) connecting parts submitted to bending and shearing stresses.</p> 	
253	<p>Double bevel continuous weld (special quality) between flange and web in the case of individual stresses within a plane through the web perpendicular to the seam.</p> 	
254	<p>Double bevel continuous weld between web and cast flange.</p> 	
<b>Case K<sub>3</sub> : Severe stress concentration</b>		
311	<p>Elements connected by single or double V butt weld carried out on one side, on a supported base, perpendicular to the stress direction.</p> 	

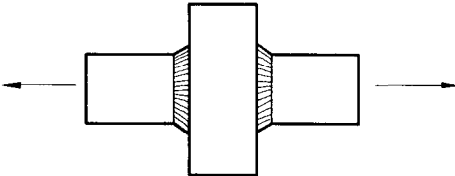

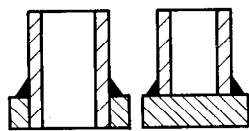

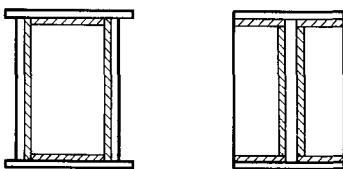

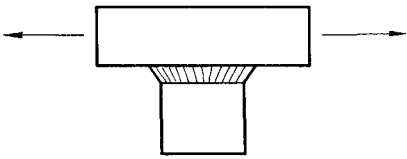



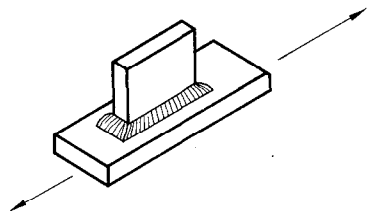

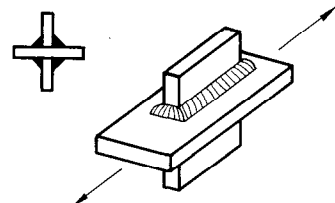
No.	Description and symbolization of the main cases	Symbol <sup>1)</sup>
<b>Case K<sub>3</sub> : Severe stress concentration (continued)</b>		
<p><b>312</b></p> <p>Parts of different thicknesses connected by single or double V butt weld perpendicular to the stress direction:</p> <ul style="list-style-type: none"> <li>— asymmetrical connecting slope: 1/2 or</li> <li>— symmetrical position without connecting slope</li> </ul>		
<p><b>313</b></p> <p>Butt weld joint and continuous element, both perpendicular to the stress direction, where the flats cross, with welded auxiliary gussets. The ends and the seams are ground, thereby avoiding forming of notches.</p>		
<p><b>314</b></p> <p>Tubes connected by single or double V butt weld, the supported base of which is not covered by a sealing run.</p>		
<p><b>331</b></p> <p>Continuous element on which parts are fixed by double fillet weld perpendicular to the stress direction.</p>		
<p><b>333</b></p> <p>Flanges and webs fixed by continuous double fillet weld to transverse web or stiffeners. The classification in the case of construction only applies to the fillet weld area.</p>		

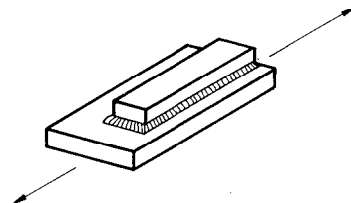

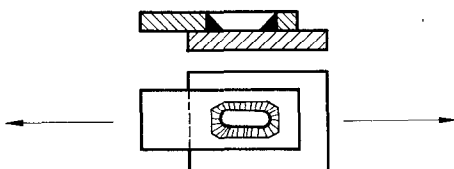

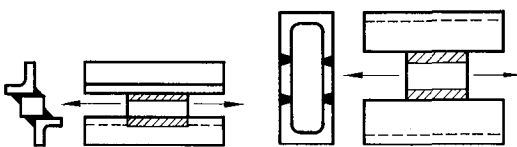

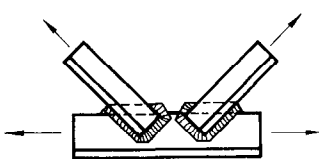



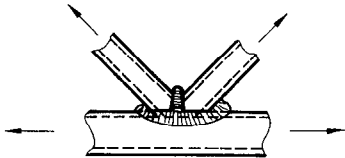

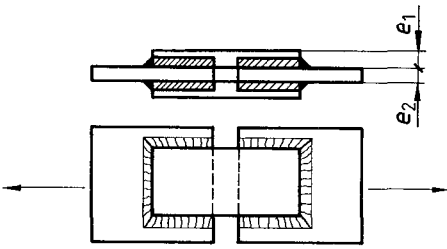
No.	Description and symbolization of the main cases	Symbol <sup>1)</sup>	
<b>Case K<sub>3</sub> : Severe stress concentration (continued)</b>			
341	<p>Continuous element at the edges of which parts parallel to the stress direction are fixed by fillet weld (special quality). These parts finish by chamfers. The ends of the seams are ground, thereby avoiding forming of notches.</p>		
342	<p>Continuous elements on which parts finishing with the corners cut off, parallel to the stress direction, are welded. These seam ends are carried out in the area <math>10e</math> in fillet weld (special quality).</p>		
343	<p>Continuous elements through which a plate with the corners cut off, welded parallel to the stress direction, is passed. The seam ends are carried out by double bevel continuous weld (special quality) in the area <math>10e</math>.</p>		
344	<p>Continuous element on which a flange is welded with <math>e_1 \leq 1,5 e_2</math>. The end of the seam is carried out in the area characterized by fillet weld (special quality).</p>		
345	<p>Element at the ends of which connecting gussets <math>e_1 \leq e_2</math> are fixed by fillet weld. The seam end is carried out in the area characterized by fillet weld (special quality). In the case of a butt strap on one side, the eccentric dynamic effect should be taken into consideration.</p>		
346	<p>Continuous element on which stiffeners parallel to the stress direction are fixed by fillet welds or by double fillet welds carried out between notches. The classification in the case of construction applies to the seam between the end seams to the calculated connection of the stiffeners.</p>		

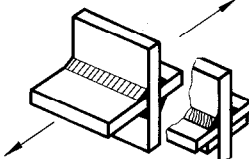
No.	Description and symbolization of the main cases	Symbol <sup>(1)</sup>
<b>Case K<sub>3</sub> : Severe stress concentration (concluded)</b>		
347	<p>Continuous element on which assembled sections are fixed by fillet welds (special quality).</p> 	
348	<p>Tube bars assembled by fillet welds (special quality).</p> 	
351	<p>Double bevel continuous welds perpendicular to the stress direction between parts which cross (cross joint).</p> 	
352	<p>Double bevel continuous weld connecting parts submitted to bending and shearing stresses.</p> 	
353	<p>Double bevel continuous weld between flange and web in the case of individual stresses within a plane through the web perpendicular to the seam.</p> 	
354	<p>Fillet weld between web and belt flange.</p> 	

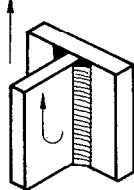
No.	Description and symbolization of the main cases	Symbol <sup>1)</sup>
<b>Case K<sub>4</sub> : Very severe stress concentration</b>		
412	<p>Parts of different thicknesses connected by single or double V butt weld perpendicular to the stress direction. Asymmetrical position without connecting slope.</p> 	
413	<p>Elements assembled by single or double V butt weld perpendicular to the stress direction where the flats cross.</p> 	
414	<p>Flanges and tubes assembled by two fillet welds or by HV welding.</p> 	
433	<p>Flanges and webs fixed by one-side continuous fillet weld (special quality) to the traverse web, perpendicular to the stress direction.</p> 	
441	<p>Continuous elements at the edges of which parts ending in right angles, parallel to the stress direction, are welded.</p> 	

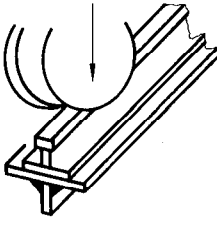
No.	Description and symbolization of the main cases	Symbol <sup>1)</sup>
<b>Case K<sub>4</sub> : Very severe stress concentration (continued)</b>		
442	<p>Continuous element on which parts of stiffeners finishing in right angles are fixed by fillet weld parallel to the stress direction.</p> 	
443	<p>Continuous element through which a plate is passed finishing in a right angle fixed by fillet weld (special quality).</p> 	
444	<p>Continuous element on which a flat is fixed by fillet weld.</p> 	
445	<p>Elements placed one on top of the other with holes or slots and fixed in the inside of the latter by fillet weld.</p> 	
446	<p>Continuous elements between which assembly plates are fixed by fillet weld or by single or double V butt weld.</p> 	
447	<p>Continuous elements on which assembled sections are fixed by fillet weld.</p> 	

No.	Description and symbolization of the main cases	Symbol <sup>1)</sup>
<b>Case K<sub>4</sub> : Very severe stress concentration (concluded)</b>		
448	<p>Tube bars assembled by fillet weld.</p> 	
449	<p>Butt straps at the end of which elements <math>e_1 \leq e_2</math> with fillet welds on the front and the side are welded.</p> 	
451	<p>Double fillet weld or HV weld carried out on one side, on the supported base, perpendicular to the stress direction, between parts which cross (cross joint).</p> 	
452	<p>Double fillet weld connecting parts submitted to bending and shearing stresses.</p> 	
453	<p>Double fillet weld between flange and web in the case of individual stresses within a plane through the web perpendicular to the seam.</p> 	
<p>1) Weld symbols are taken from ISO 2553.</p>		

**Table 19 — Allowable fatigue strength,  $\sigma_D$  (N/mm<sup>2</sup>)**

Tension and compression in the material and in the weld joints for construction cases  $W_0$  to  $K_4$

**Class A units** (see 7.2.1)

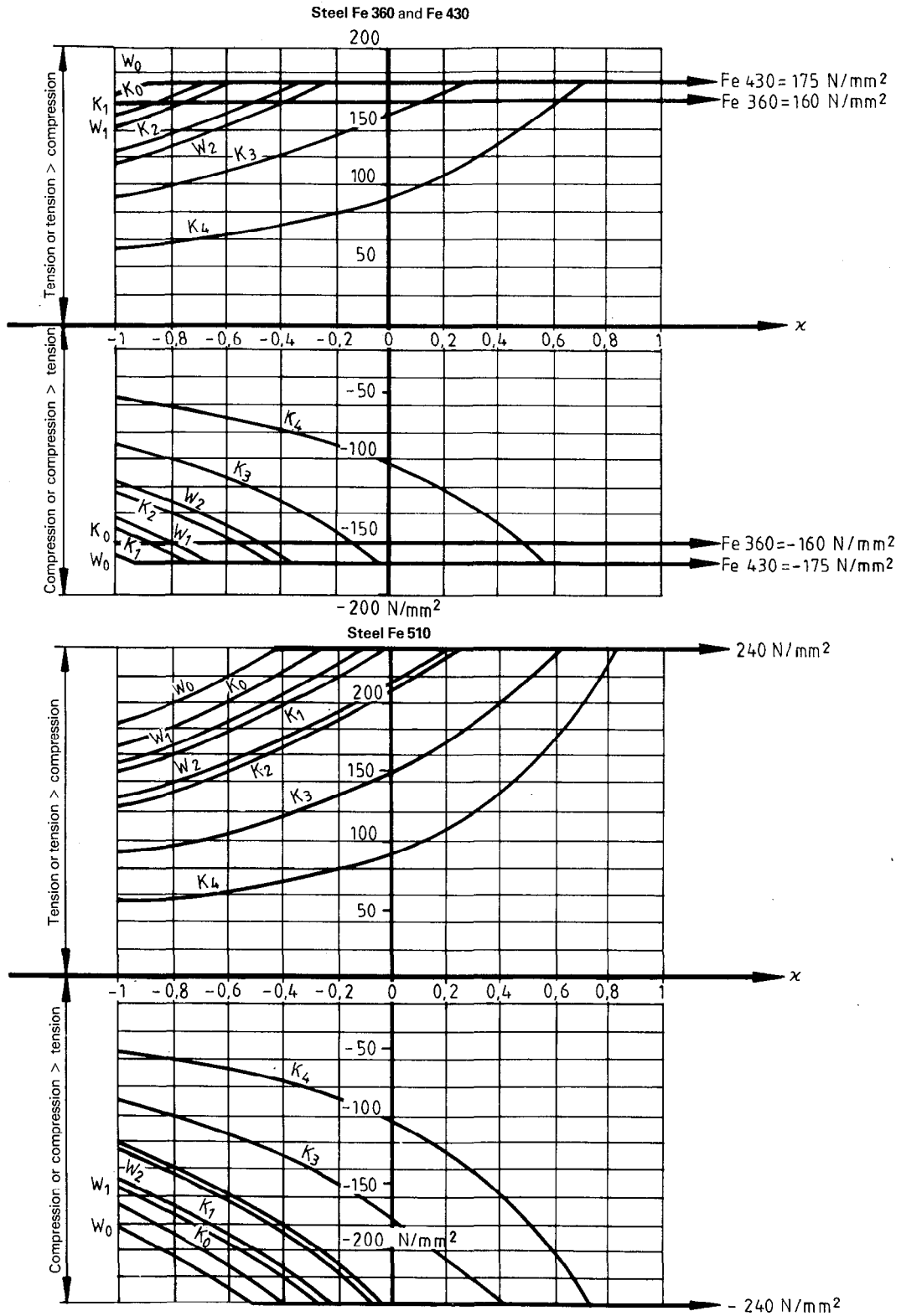

**Table 20 — Allowable fatigue strength,  $\sigma_D$  (N/mm<sup>2</sup>)**

Tension and compression in the material and in the weld joints for construction cases  $W_0$  to  $K_4$   
**Class B units** (see 7.2.1)

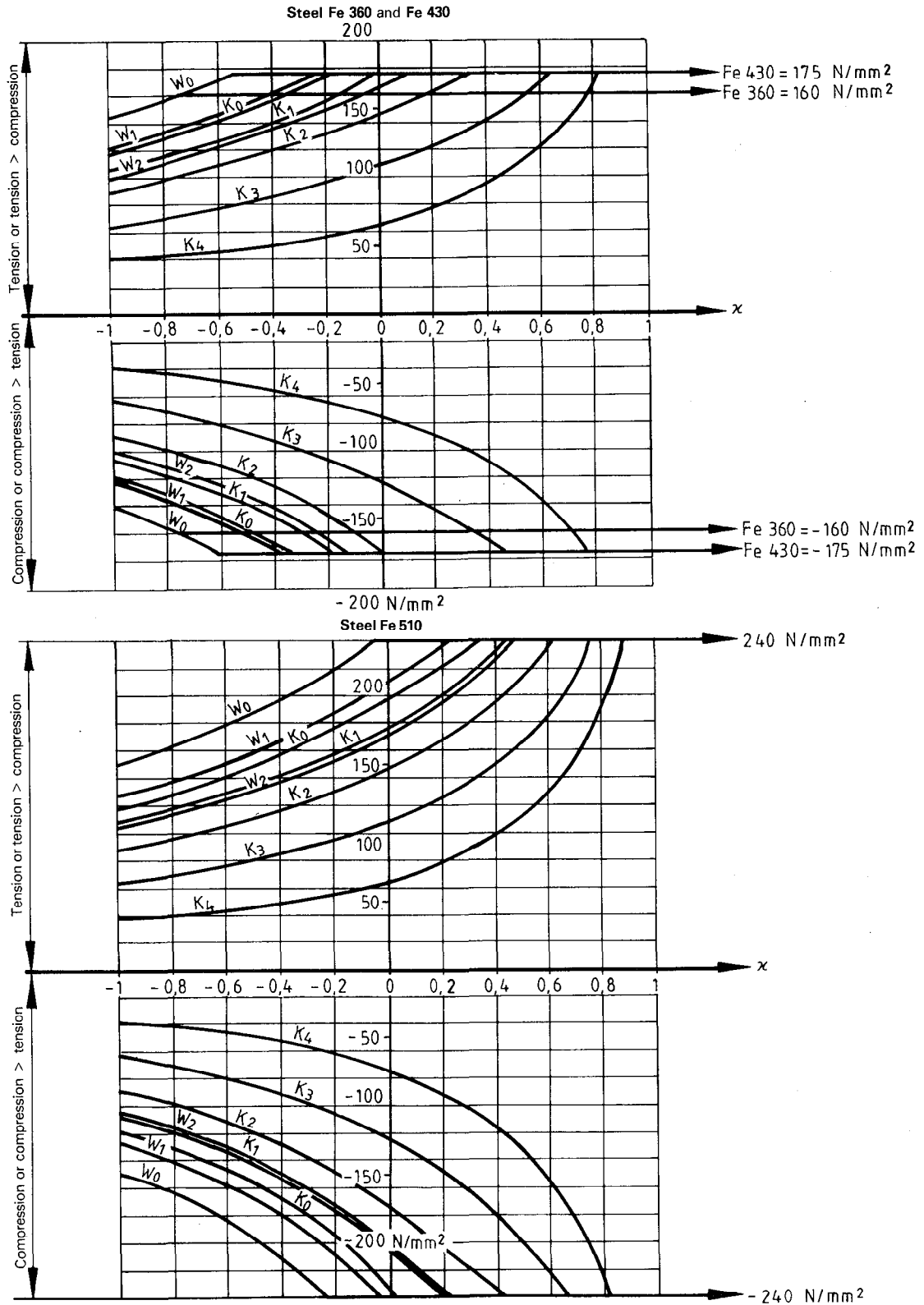

**Table 21 — Allowable fatigue strength,  $\sigma_D$  (N/mm<sup>2</sup>)**

Tension and compression in the material and in the weld joints for construction cases  $W_0$  to  $K_4$

**Class C units** (see 7.2.1)

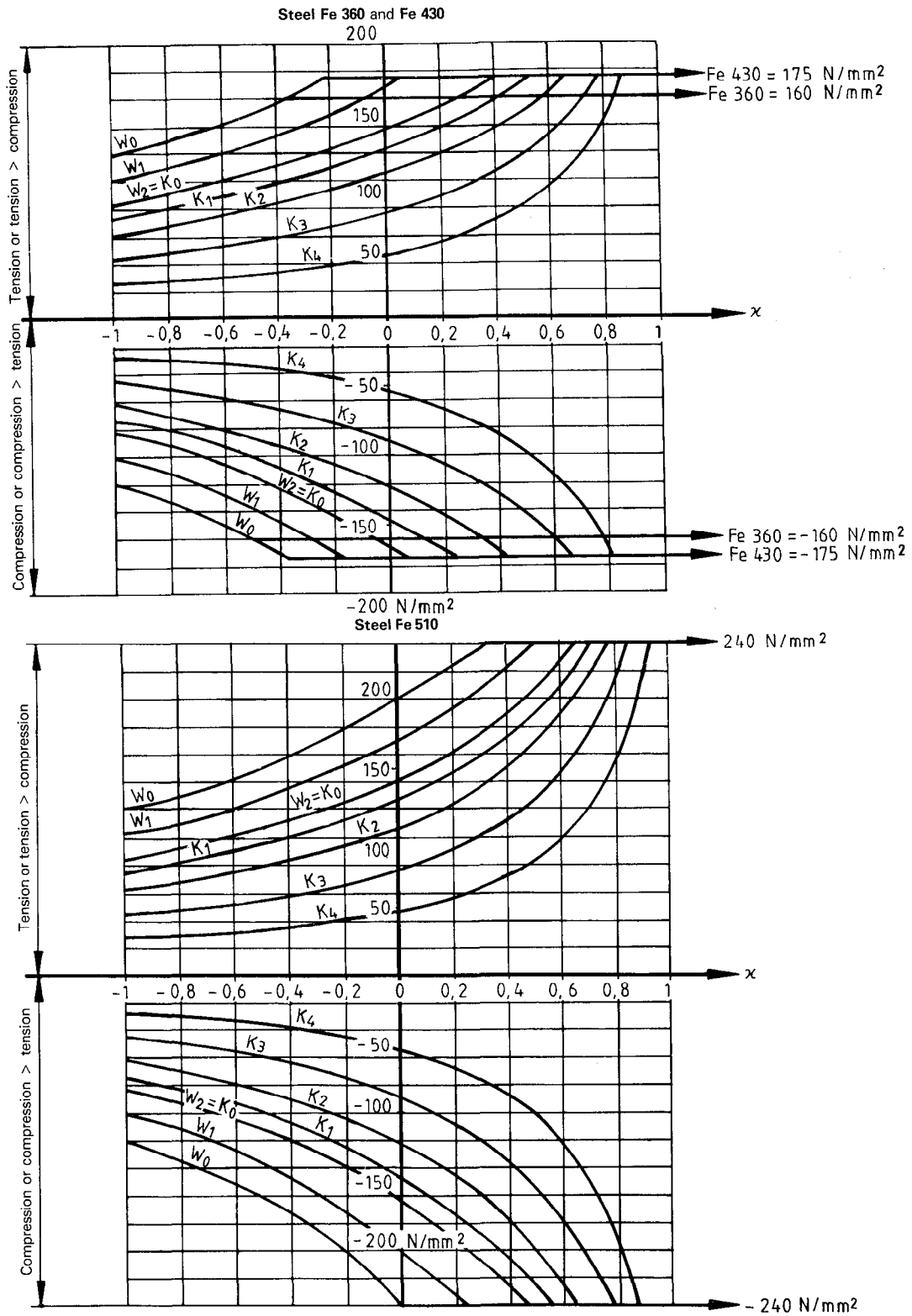

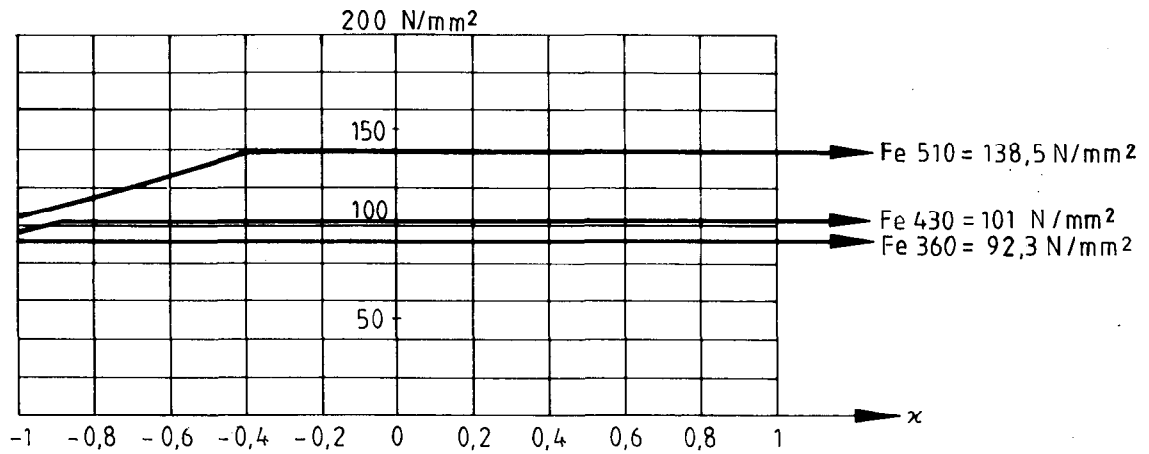

**Table 22 — Allowable fatigue strength,  $\tau_D$  (N/mm<sup>2</sup>)**

Shear in the material and in the weld joints

**Class A units** (see 7.2.1)

For the parent metal



For the weld joints

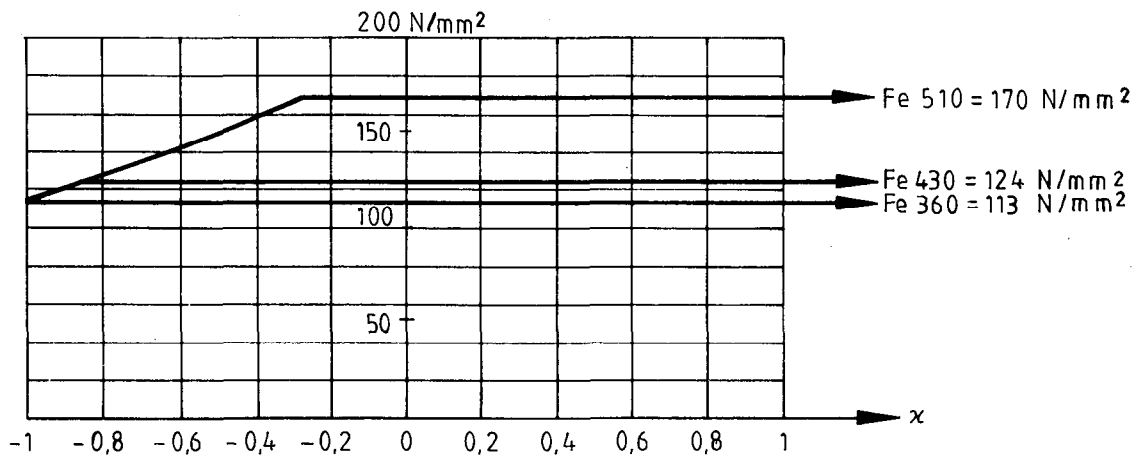
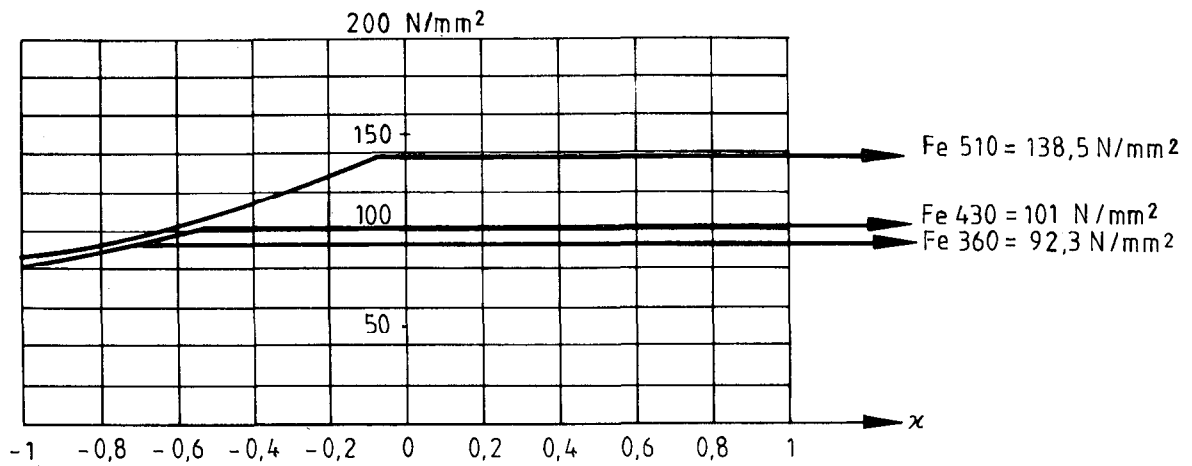

**Table 23 — Allowable fatigue strength,  $\tau_D$  (N/mm<sup>2</sup>)**

Shear in the material and in the weld joints

**Class B units** (see 7.2.1)

For the parent metal



For the weld joints

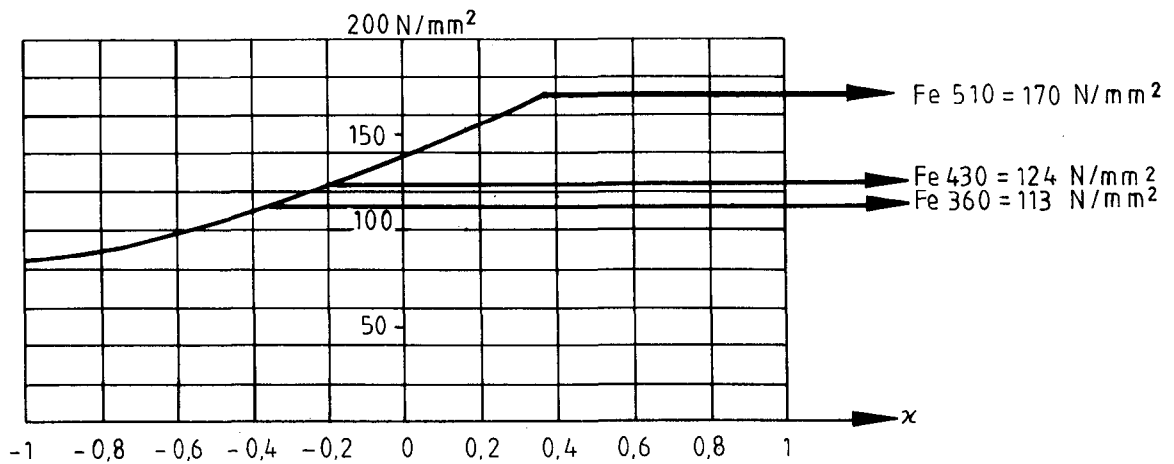
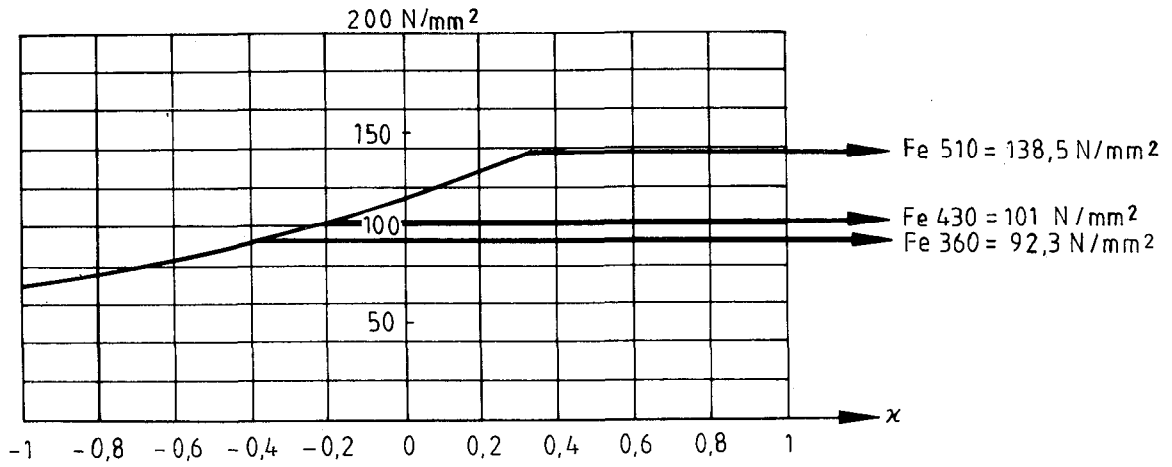

**Table 24 — Allowable fatigue strength,  $\tau_D$  (N/mm<sup>2</sup>)**

Shear in the material and in the weld joints

Class C units (see 7.2.1)

For the parent metal



For the weld joints

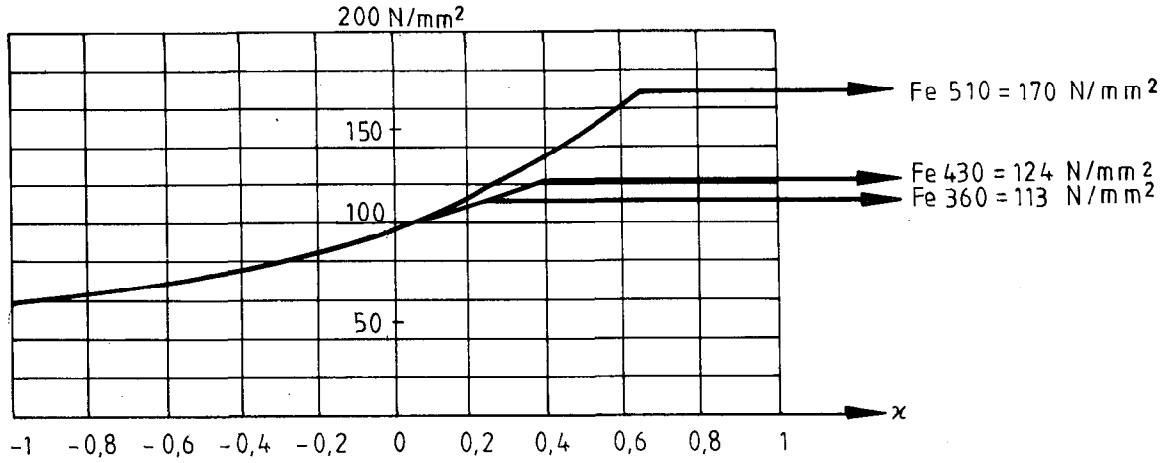
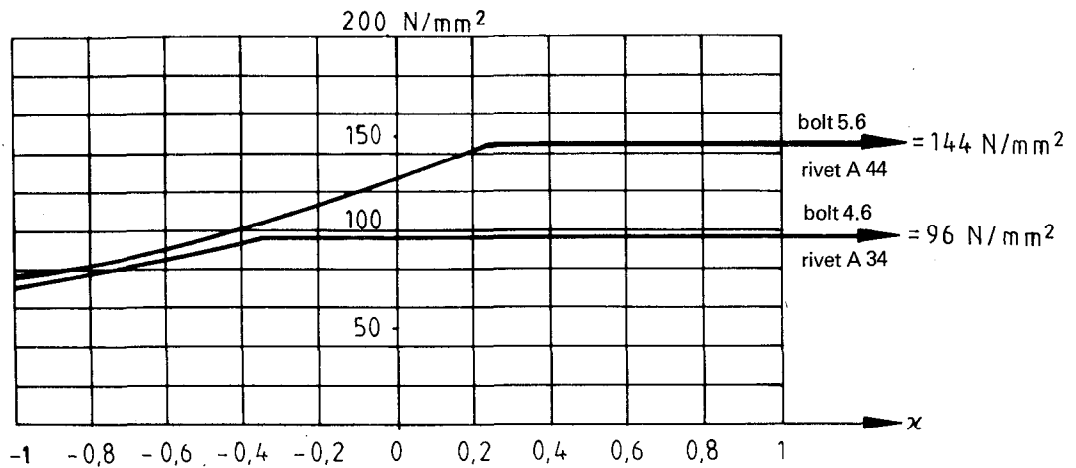

**Table 25 — Allowable fatigue strength,  $\tau_{SD}$  (N/mm<sup>2</sup>)**

Shear in fitted bolts and rivets

**Class A units** (see 7.2.1)

**Single-shear joint**



ISO tolerance for fitted bolts

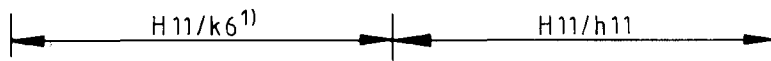

**Multiple-shear joint**

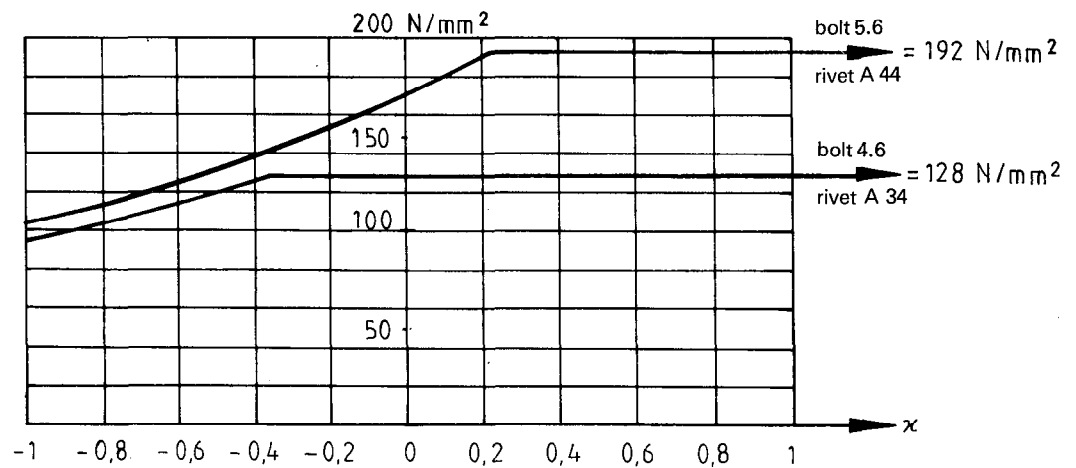

ISO tolerance for fitted bolts



1) See ISO 286-2.

**Table 26 — Allowable fatigue strength,  $\tau_{SD}$  (N/mm<sup>2</sup>)**

Shear in fitted bolts and rivets

**Class B units** (see 7.2.1)

**Single-shear joint**

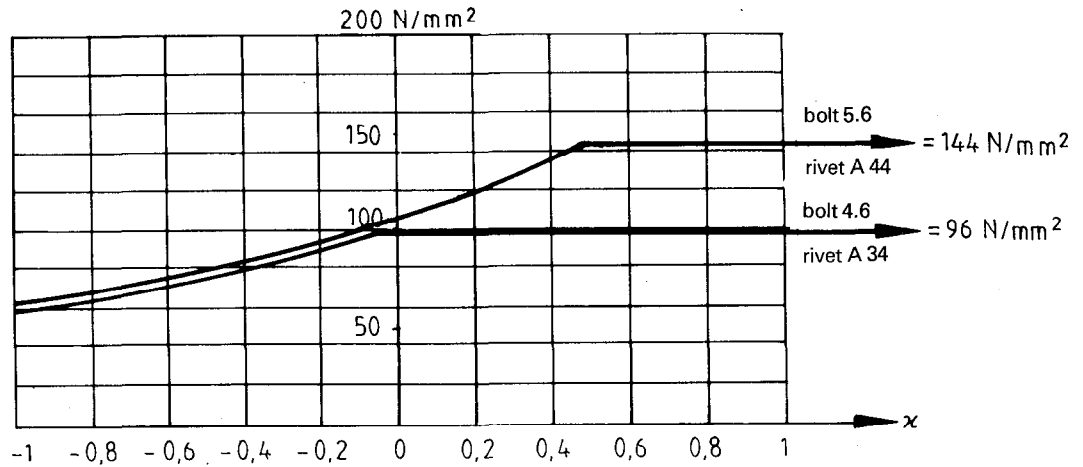

ISO tolerance for fitted bolts

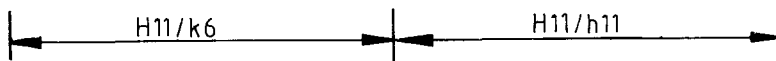

**Multiple-shear joint**

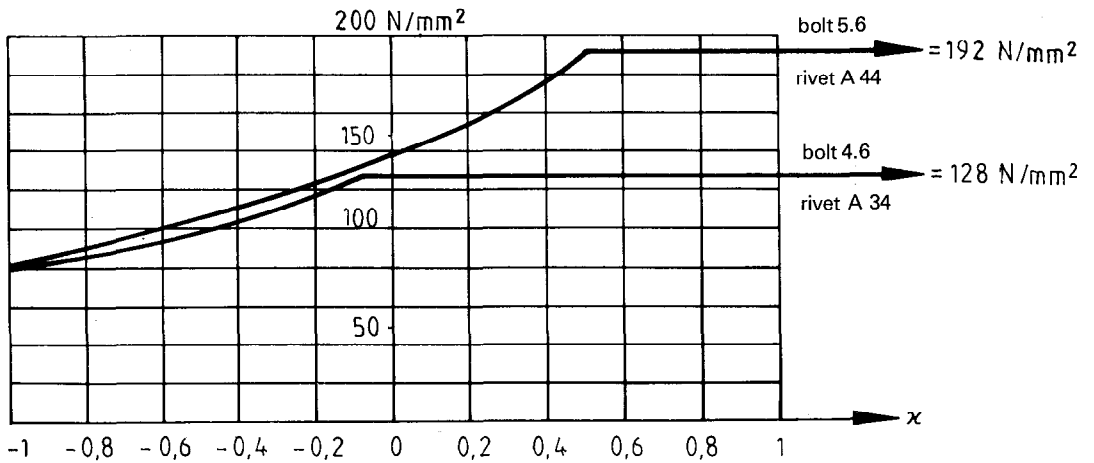

ISO tolerance for fitted bolts



**Table 27 — Allowable fatigue strength,  $\tau_{SD}$  (N/mm<sup>2</sup>)**

Shear in fitted bolts and rivets

**Class C units** (see 7.2.1)

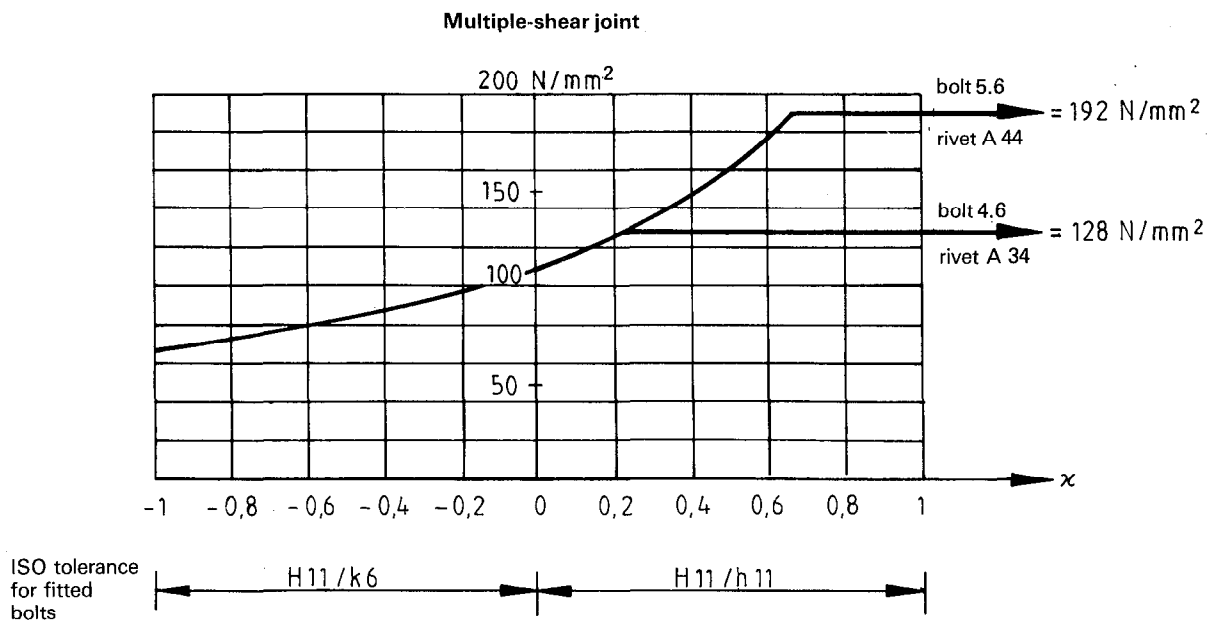
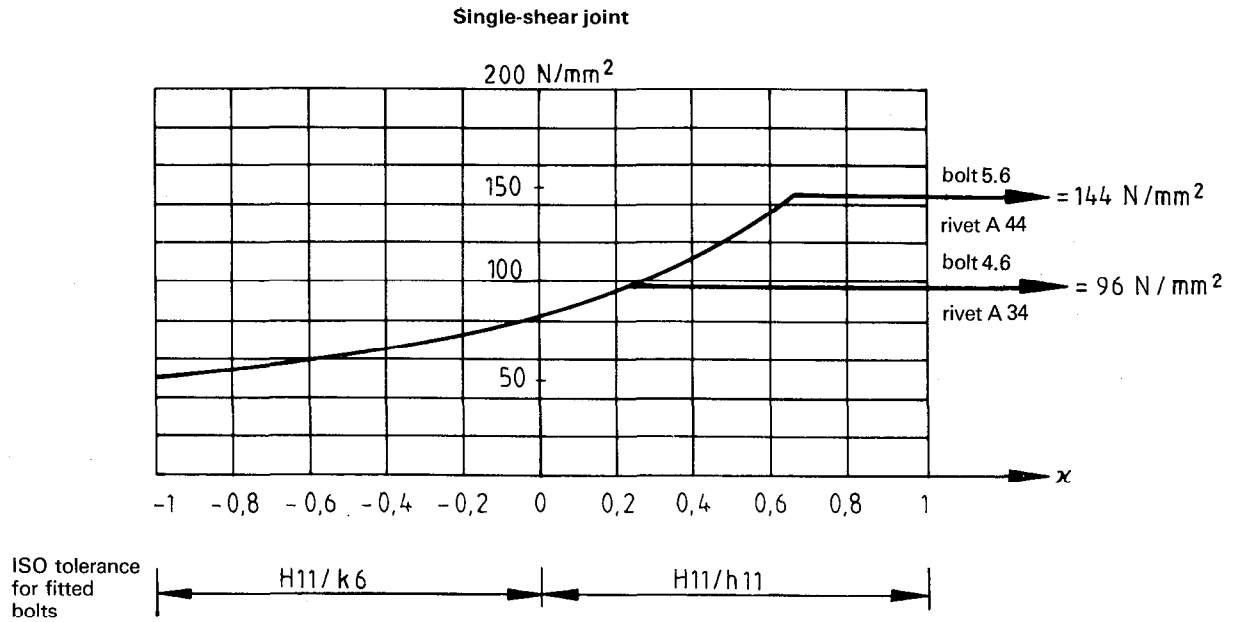

**Table 28 — Allowable diametral pressures,  $\sigma_{ID}$  (N/mm<sup>2</sup>)**

Fitted bolts and rivets

Class A units (see 7.2.1)

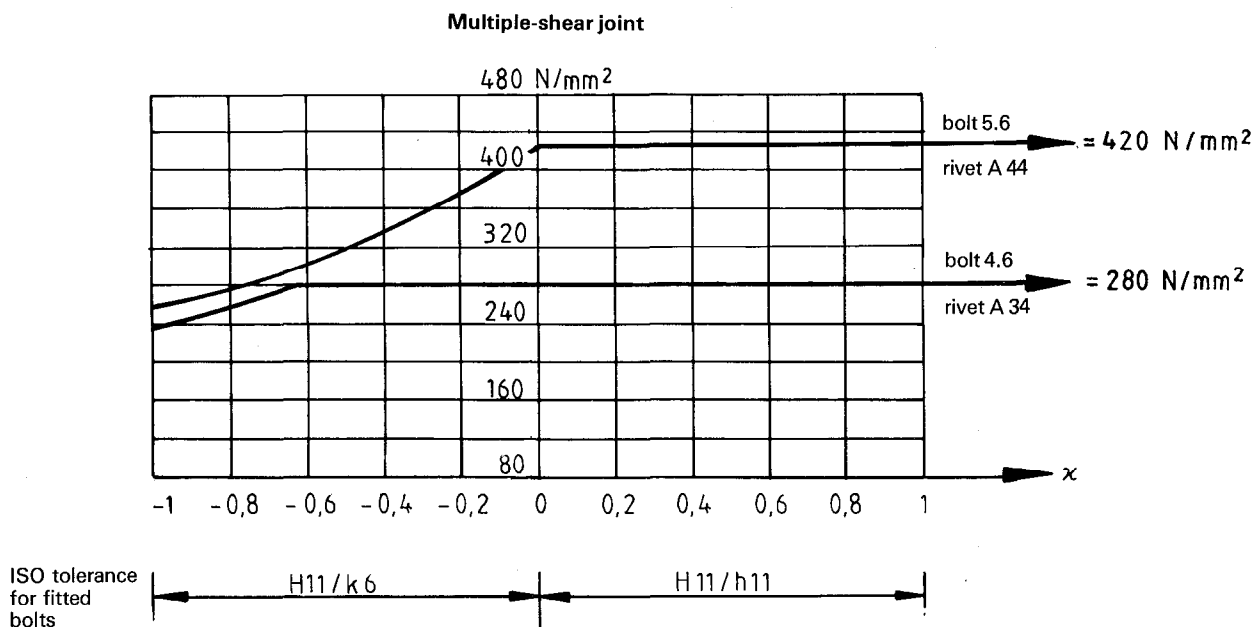
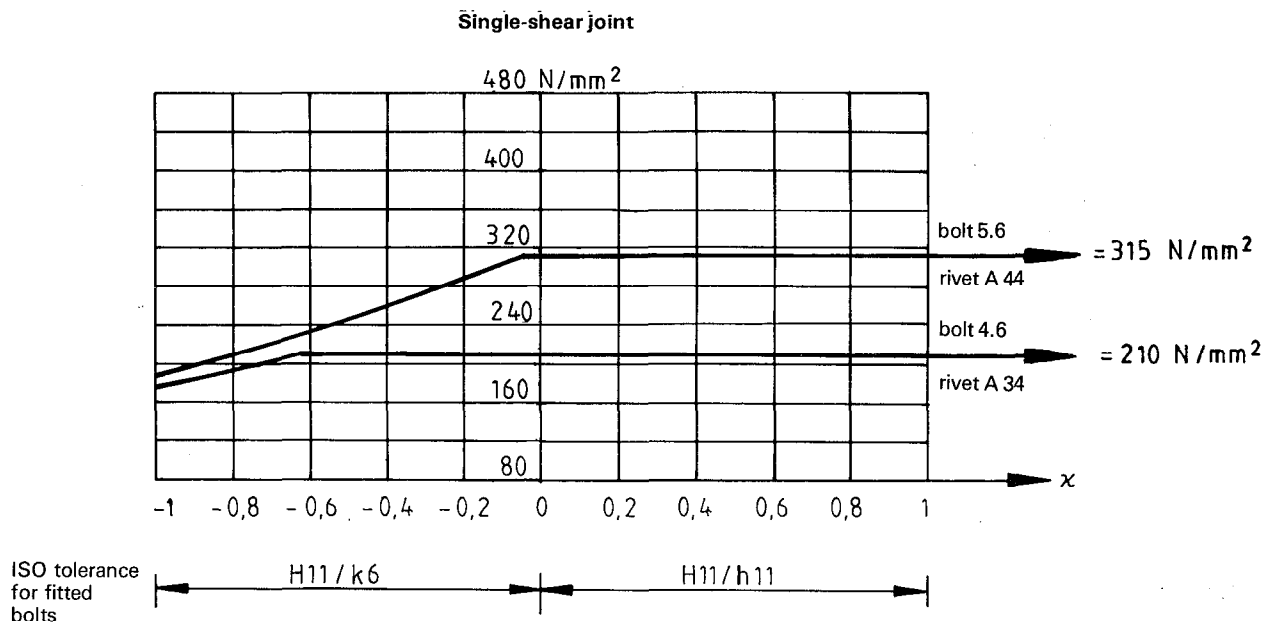

**Table 29 — Allowable diametral pressures,  $\sigma_{ID}$  (N/mm<sup>2</sup>)**

Fitted bolts and rivets

**Class B units** (see 7.2.1)

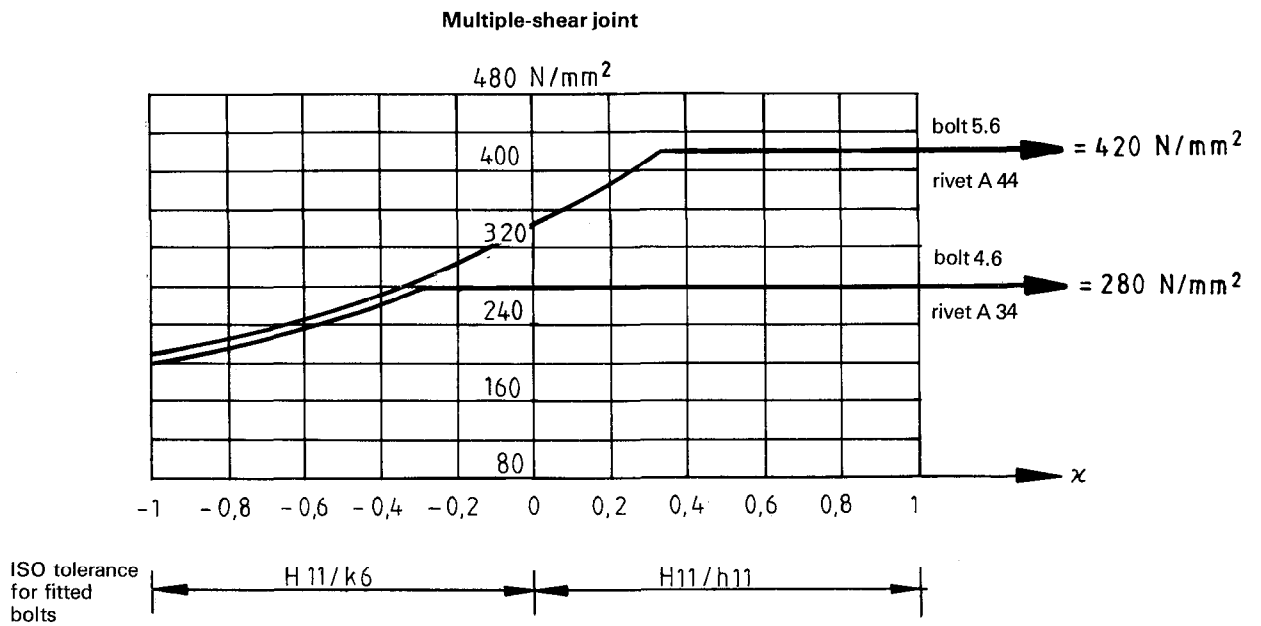
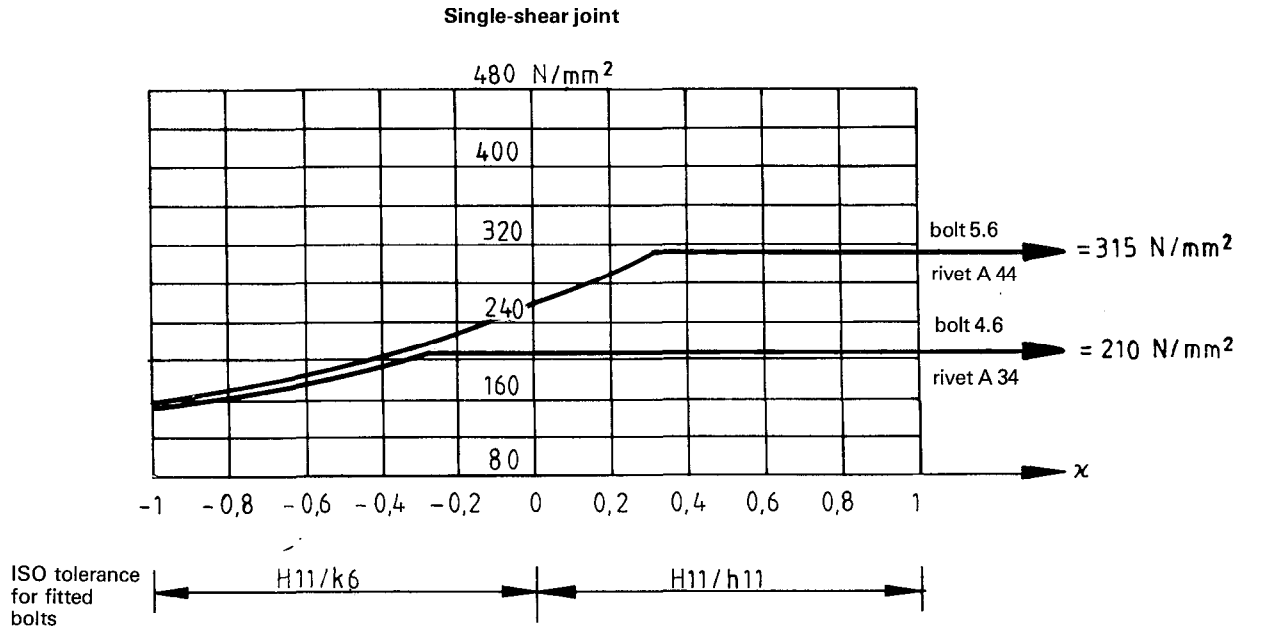

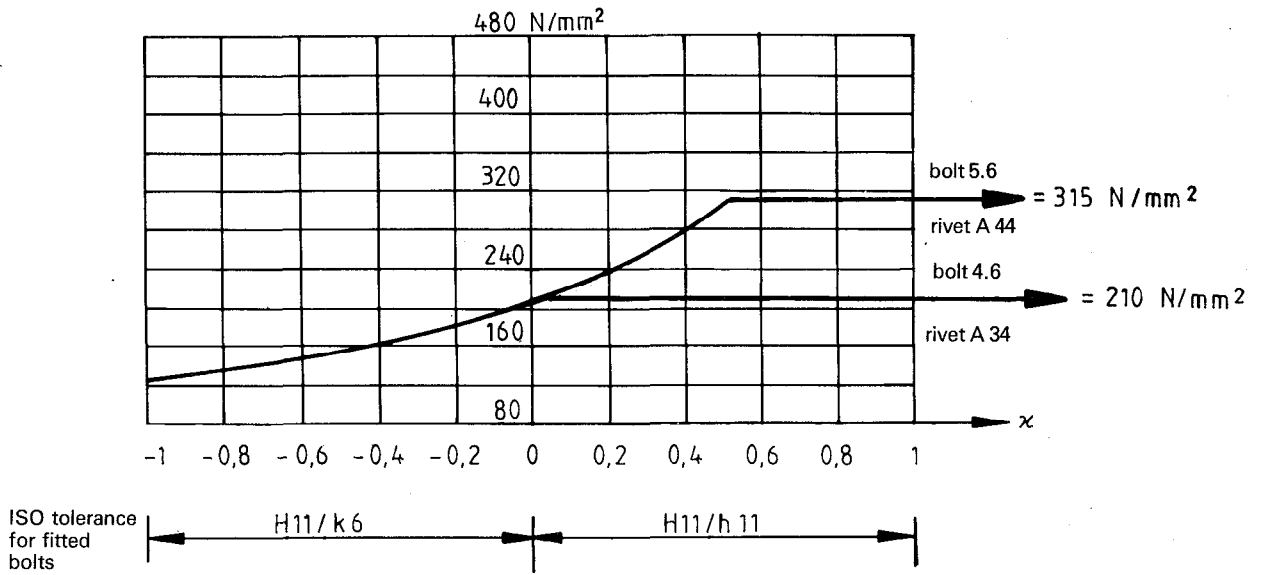

**Table 30 — Allowable diametral pressures,  $\sigma_{ID}$  (N/mm<sup>2</sup>)**

Fitted bolts and rivets

Class C units (see 7.2.1)

**Single-shear joint**



**Multiple-shear joint**

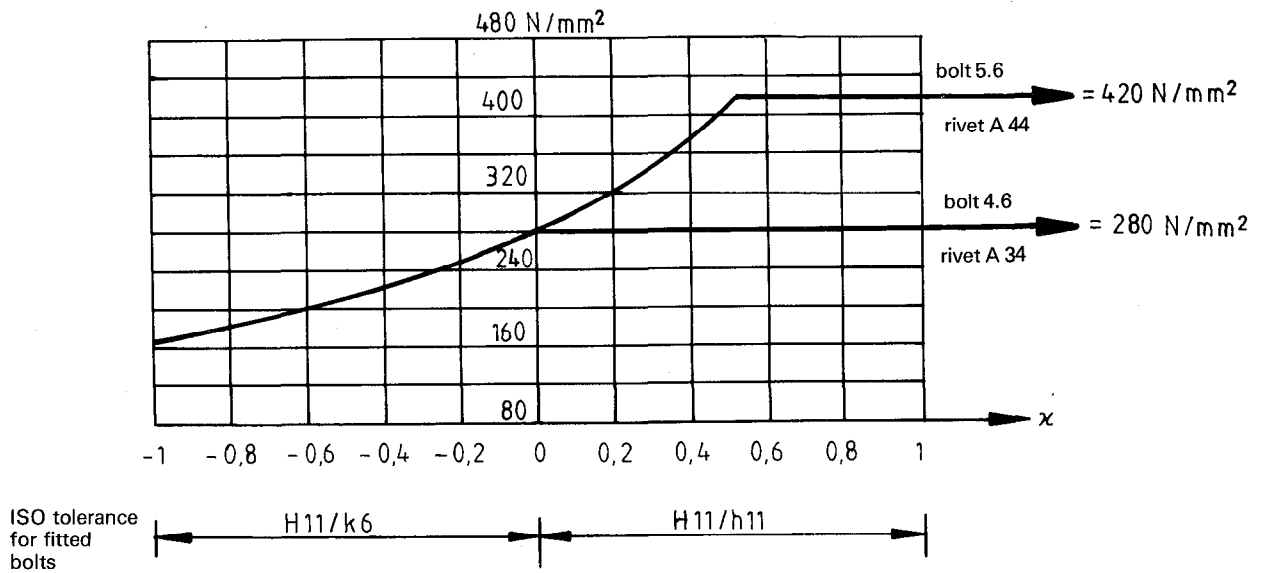

## 8 Exceeding allowable stresses

The final construction weights shall be compared with the weight used in the static calculation. If the final dead loads do not exceed the weights used in the static calculation by more than 5 %, there is no need to carry out a new check.

## 9 Safety against overturning

### 9.1 Checking for safety against overturning

For safety against overturning, the following ratio shall be applied:

$$v_k = \frac{M_s}{M_k}$$

where

$M_s$  is the stabilizing moment of the total permanent load referred to a possible tipping axis;

$M_k$  is the overturning moment resulting from all the variable horizontal and vertical forces ( $= \Sigma P_H + \Sigma P_V$ ) of load cases I, II and III, to the extent these forces increase the overturning moment.

The check shall be carried out for the tipping axis with the smallest overturning safety, by assuming that the movable parts of the dead load are in the most unfavourable position.

The same safety regarding overturning can be written in the following form (see figure 5):

$$v_k = \frac{M_s}{M_k} = \frac{f e}{1 - \frac{\Sigma P_V}{G} \left( \frac{f}{e} - 1 \right)}$$

where

$f$  is the horizontal distance of the centre of gravity of the dead load  $G$  from a possible overturning axis;

$e$  is given by

$$e = \frac{\Sigma P_H h + \Sigma P_V (a + f)}{G + \Sigma P_V}$$

in which

$h$  is the vertical distance of the sum of all the horizontal forces ( $\Sigma P_H$ ) from the tipping axis;

$a$  is the horizontal distance of the sum of all the vertical forces ( $\Sigma P_V$ ) from the tipping axis.

The safety factors against overturning specified in table 31 are at least requested for load cases I to III.

Table 31 — Safety against overturning

$$v_k = M_s/M_k$$

Load case	$v_k$
I	1,5
II	1,3
III	1,2

### 9.2 Additional precautions

On agreement with the user, it can be specified that different structural members shall occupy definite positions, taking into account the stability of the appliance when idle (for example crane boom). Such measures shall appear in the operating instructions.

## 10 Safety against drifting

As safety against drifting, the ratio is taken between the sum of the drag forces and the sum of the drift forces due to the wind or the inclination. The calculation shall be based on the greatest inclination at which the machine has to work, in accordance with 3.1.7. The resting of the digging device on the face or ground need not, in this case, be taken into consideration.

The friction values to be used are as follows:

— for driven wheels on rails:  $\mu = 0,14$

— for non-driven ball-mounted wheels:  $\mu = 0,01$

— for non-driven wheels with bushes:  $\mu = 0,015$

— for rail clamps, if no higher values are found by testing:  $\mu = 0,25$

The safety against drifting shall be

a) in operation, when only the automatic brakes of the drive motors act, in the case of wind-induced load, according to 3.2.1,  $v \geq 1,3$ ;

b) out of operation, with wind-induced stresses according to 3.3.6,  $v \geq 1,2$ .

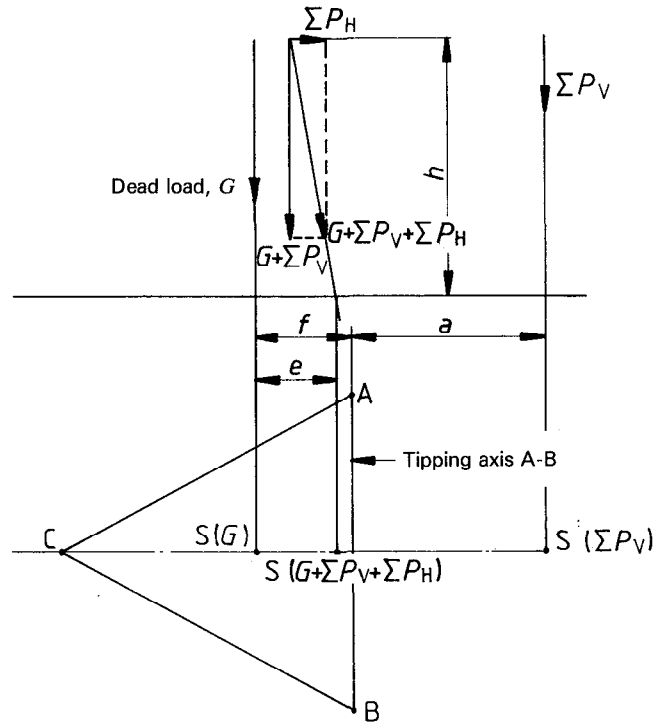

Figure 5 — Safety against overturning

## **Annex A**

(informative)

### **Bibliography**

- [1] ISO 2553:1992, *Welded, brazed and soldered joints — Symbolic representation on drawings.*
- [2] ISO 5817:1992, *Arc-welded joints in steel — Guidance on quality levels for imperfections.*
- [3] ISO 6520:1982, *Classification of imperfections in metallic fusion welds, with explanations.*

---

---

**ICS 53.040.00**

**Descriptors:** bulk products, continuous handling, mobile equipment, handling equipment, materials handling equipment, steel construction, specifications, rules of calculation.

Price based on 48 pages

---

---