**Dense shaped refractory products —
Determination of bulk density,
apparent porosity and true porosity**

*Produits réfractaires façonnés denses — Détermination de la masse
volumique apparente, de la porosité ouverte et de la porosité totale*



Reference number
ISO 5017:2013(E)

© ISO 2013



COPYRIGHT PROTECTED DOCUMENT

© ISO 2013

All rights reserved. Unless otherwise specified, no part of this publication may be reproduced or utilized in any form or by any means, electronic or mechanical, including photocopying and microfilm, without permission in writing from either ISO at the address below or ISO's member body in the country of the requester.

ISO copyright office
Case postale 56 • CH-1211 Geneva 20
Tel. + 41 22 749 01 11
Fax + 41 22 749 09 47
E-mail copyright@iso.org
Web www.iso.org

Published in Switzerland

Contents

	Page
Foreword	iv
1 Scope	1
2 Normative references	1
3 Terms and definitions	1
4 Principle	2
5 Apparatus and materials	2
6 Number and shape of test pieces	3
7 Procedure	3
7.1 Determination of mass of dry test piece (m_1)	3
7.2 Soaking of test piece	3
7.3 Determination of apparent mass of immersed test piece (m_2)	4
7.4 Determination of mass of soaked test piece (m_3)	4
7.5 Determination of density of immersion liquid	4
8 Expression of results	4
9 Test report	5

Foreword

ISO (the International Organization for Standardization) is a worldwide federation of national standards bodies (ISO member bodies). The work of preparing International Standards is normally carried out through ISO technical committees. Each member body interested in a subject for which a technical committee has been established has the right to be represented on that committee. International organizations, governmental and non-governmental, in liaison with ISO, also take part in the work. ISO collaborates closely with the International Electrotechnical Commission (IEC) on all matters of electrotechnical standardization.

International Standards are drafted in accordance with the rules given in the ISO/IEC Directives, Part 2.

The main task of technical committees is to prepare International Standards. Draft International Standards adopted by the technical committees are circulated to the member bodies for voting. Publication as an International Standard requires approval by at least 75 % of the member bodies casting a vote.

Attention is drawn to the possibility that some of the elements of this document may be the subject of patent rights. ISO shall not be held responsible for identifying any or all such patent rights.

ISO 5017 was prepared by Technical Committee ISO/TC 33, *Refractories*.

This third edition cancels and replaces the second edition (ISO 5017:1998), which has been technically revised.

Dense shaped refractory products — Determination of bulk density, apparent porosity and true porosity

1 Scope

This International Standard specifies a method for the determination of the bulk density, apparent porosity and true porosity of dense shaped refractory products.

2 Normative references

The following documents, in whole or in part, are normatively referenced in this document and are indispensable for its application. For dated references, only the edition cited applies. For undated references, the latest edition of the referenced document (including any amendments) applies.

ISO 758, *Liquid chemical products for industrial use — Determination of density at 20 °C*

ISO 5018, *Refractory materials — Determination of true density*

3 Terms and definitions

For the purposes of this document, the following terms and definitions apply.

3.1 bulk density

ρ_b

ratio of the mass of the dry material of a porous body to its bulk volume, expressed in grams per cubic centimetre or in kilograms per cubic metre

3.2 bulk volume

V_b

sum of the volumes of the solid material, the open pores and the closed pores in a porous body

Note 1 to entry: The roughness of the surface limits the accuracy of definition of the bulk volume and consequently, that of the bulk density. Also, the concept of bulk density becomes less precise when the volume of the sample diminishes below certain limits or when its texture (size of pores and grains) is too coarse.

3.3 true density

ρ_t

ratio of the mass of the dry material of a porous body to its true volume, expressed in grams per cubic centimetre or in kilograms per cubic metre, determined in accordance with ISO 5018

3.4 true volume

volume of the solid material in a porous body

3.5 open pores

those pores that are penetrated by the immersion liquid in the test described

Note 1 to entry: These pores are, in principle, all those that are connected with the atmosphere, either directly or via one another. Here also the roughness of the surface imposes a limit to the accuracy of the definition of the volume of the open pores.

3.6

closed pores

those pores that are not penetrated by the immersion liquid in the test described

3.7

apparent porosity

π_a
ratio of the total volume of the open pores in a porous body to its bulk volume, expressed as a percentage of the bulk volume

3.8

closed porosity

π_f
ratio of the total volume of the closed pores in a porous body to its bulk volume, expressed as a percentage of the bulk volume

3.9

true porosity

π_t
the ratio of the total volume of the open and closed pores to the bulk volume of the material, expressed as a percentage

Note 1 to entry: Consequently, the true porosity is the sum of the apparent porosity and the closed porosity.

3.10

dense shaped refractory product

product having a true porosity of less than 45 % (V/V)

4 Principle

4.1 The following are determined by weighing:

the mass of a dry test piece;

its apparent mass when immersed in a liquid with which it has been impregnated under vacuum;

its mass in air while still soaked with the liquid.

From these values and from the true density of the material, determined by the method specified in ISO 5018, the bulk density, apparent porosity and true porosity are determined by calculation.

4.2 The precision of the results does not require any correction to be made for the fact that weighings are carried out in air, not in a vacuum.

5 Apparatus and materials

5.1 **Drying oven**, capable of being controlled at $150\text{ °C} \pm 10\text{ °C}$.

NOTE A fan-assisted oven with ventilation would assist in attaining an even temperature distribution and efficient drying of the test pieces.

5.2 **Balance**, with an accuracy of $\pm 0,01\text{ g}$, that can be arranged so that test pieces can be suspended in the immersion liquid (see Figure 1).

5.3 **Beakers**, of a suitable size for containing the samples during soaking (see 7.2) and when determining the apparent immersed mass (see 7.3).

5.4 Evacuating equipment, capable of reducing the absolute pressure to a value no greater than 2 500 Pa (0,025 bar) and a means of measuring the pressure used (see Figure 1).

5.5 Thermometer, accurate to ± 1 °C.

5.6 Immersion liquid. For materials that do not react with water, the immersion liquid may be cold distilled water or deionized water. For materials that are sensitive to contact with water, a suitable organic liquid shall be used. The immersion liquid shall not fractionate at a pressure above the absolute pressure attained in the test. The liquid shall be exchanged when staining or haze appears.

NOTE Distilled paraffin may be used for hydratable materials.

5.7 Desiccator.

6 Number and shape of test pieces

6.1 The number of items (for example, bricks, shapes, nozzles) to be tested shall be a minimum of two items per batch or shall be otherwise determined by agreement between the interested parties.

6.2 The number of test pieces to be tested per item shall be agreed between the parties and shall be stated in the test report. If the test pieces are cut out of bricks or blocks, the same number shall be cut from each one, in order to facilitate statistical analysis.

6.3 Test pieces shall be cut in the form of prisms or cylinders. The bulk volume of a test piece shall be not less than 50 cm³, and shall be not more than 200 cm³. The ratio of the longest to the shortest dimension of a test piece shall not exceed 2:1.

NOTE 1 Where it is not possible to obtain the given size and volume from the item, test pieces of other dimensions and volume may be used by agreement between parties, and are to be reported.

NOTE 2 If test pieces are to be cut from an item in which variations in density could occur, the position of the test pieces should be agreed between parties and stated in the test report.

6.4 Any test piece showing cracks shall be eliminated, since these might falsify the determination of the bulk volume.

7 Procedure

7.1 Determination of mass of dry test piece (m_1)

See Figure 1.

Dry the test piece at $110^\circ\text{C} \pm 5$ °C to constant mass, i.e. until two successive weighings made before and after at least 2 h in the oven (5.1) do not differ by more than 0,1 %.

NOTE Alkaline products may be dried to $150^\circ\text{C} \pm 10$ °C to quickly pass the critical temperature range of hydration.

Before each weighing, place the test piece in a desiccator (5.7) until it has cooled to room temperature. Weigh each test piece to the nearest 0,01 g. The mass determined is the mass of the dry test piece (m_1).

7.2 Soaking of test piece

See Figure 1.

Carry out a check test to ensure that the apparatus will hold a vacuum. Place the cooled and dried test piece in an airtight vessel. After sealing the vessel, evacuate it until a pressure of not more than 2 500 Pa

is attained; maintain this vacuum for at least 15 min. In order to ensure that all the air has been removed from the open pores, isolate or disconnect the vessel from the vacuum pump (5.4) and check that the pressure does not rise through any de-gassing of the test piece. Re-connect the vessel to the vacuum pump and progressively introduce the immersion liquid (5.6) so that, after 3 min, the test piece is covered by about 20 mm of liquid. Maintain this reduced pressure for 30 min, then switch off the pump and open the vessel. Wait a further 30 min to ensure that the liquid penetrates into all the open pores. The test piece or test pieces shall remain covered by the immersion liquid throughout the impregnation and until removed for subsequent weighing (see 7.3 and 7.4).

NOTE Certain fine porosity materials such as refractories containing carbon and some clay products may require longer periods of evacuation and soaking. If a different soaking time is used, this time should be stated in the test report.

7.3 Determination of apparent mass of immersed test piece (m_2)

See Figure 2.

Suspend the test piece by a thin thread from the load-pan suspension point of a balance (5.2) and weigh it while completely immersed in a quantity of the immersion liquid, contained in a beaker (5.3) standing on the bridge, if used. In this way, the apparent mass of the immersed test piece is obtained (m_2). The weighing shall be made to the nearest 0,01 g. Determine the temperature of the immersion liquid to an accuracy of ± 1 °C.

7.4 Determination of mass of soaked test piece (m_3)

Prepare a linen cloth by saturating it in the immersion liquid and lightly wringing it out by hand before each use. Fold the cloth and lay flat on a bench.

NOTE If a new cloth is being used, it should be washed three times to remove the dressing.

Remove the test piece from the liquid and immediately remove the excess liquid by quickly rolling the test piece over a damp cloth on all four sides and then blot the two ends. The aim of undertaking this action quickly is to ensure that liquid is not drawn out of the pores.

Immediately weigh the test piece in air to the nearest 0,01g. Take care to ensure that evaporation of the immersion liquid does not lead to any appreciable loss in mass during the weighing operation. In this way, the mass of the soaked test piece is obtained (m_3).

7.5 Determination of density of immersion liquid

Determine the density ρ_{liq} of the immersion liquid used in the operation at the temperature of the test in grams per cubic centimetre or in kilograms per cubic metre. If water is used, the accuracy of the test is such that its density between 15 °C and 30 °C can be assumed to be 1,0 g/cm³. Refer also to ISO 758.

8 Expression of results

8.1 The bulk density ρ_b , expressed in grams per cubic centimetre, is given by the equation

$$\rho_b = \frac{m_1}{m_3 - m_2} \times \rho_{liq} \quad (1)$$

The bulk density shall be expressed in grams per cubic centimetre or in kilograms per cubic metre [by multiplying the result from Equation (1) by 10³]. The value shall be given to three significant digits.

8.2 The apparent porosity π_a , expressed as a percentage by volume, is given by the equation

$$\pi_a = \frac{m_3 - m_1}{m_3 - m_2} \times 100 \quad (2)$$

8.3 The true porosity π_t , expressed as a percentage by volume, is given by the equation

$$\pi_t = \frac{\rho_t - \rho_b}{\rho_t} \times 100 \quad (3)$$

The closed porosity π_f , expressed as a percentage by volume, may be calculated by the equation

$$\pi_f = \pi_t - \pi_a \quad (4)$$

The values of porosity shall be given to the nearest 0,1 % (V/V).

9 Test report

The test report shall include the following information:

- a) the name of the testing establishment;
- b) the date of the test;
- c) a reference to this International Standard, i.e. determined in accordance with ISO 5017:2013;
- d) the description of the test material (manufacturer, type, batch number);
- e) the number of items tested;
- f) the number of test pieces per item and, if relevant, their position;
- g) the pressure to which the vacuum chamber was reduced;
- h) the immersion liquid used;
- i) the individual values and the mean value of the bulk density, apparent porosity and true porosity for each item.

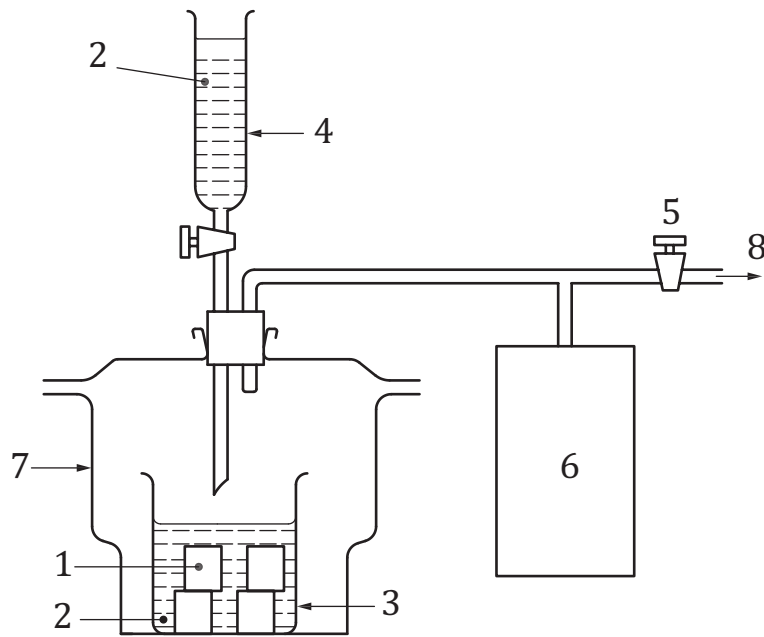

Key

- 1 Test pieces
- 2 Immersion liquid
- 3 Beaker
- 4 Tap funnel
- 5 Pump isolation valve
- 6 Pressure-measuring device (e.g. manometer)
- 7 Desiccator
- 8 Air outlet (to vacuum pump)

Figure 1 — Example of a vacuum system for soaking test pieces

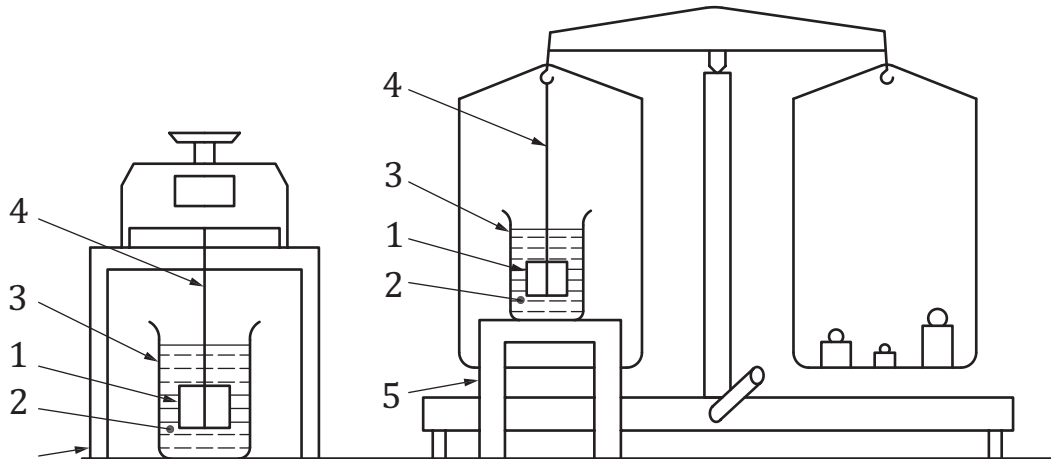
**Key**

- 1 Test piece
- 2 Immersion liquid
- 3 Beaker
- 4 Suspension thread
- 5 Bridge

Figure 2 — Example of arrangement for the determination of apparent mass of immersed test piece using single- and double-pan balances

