

---

# INTERNATIONAL STANDARD 5005

---

INTERNATIONAL ORGANIZATION FOR STANDARDIZATION • МЕЖДУНАРОДНАЯ ОРГАНИЗАЦИЯ ПО СТАНДАРТИЗАЦИИ • ORGANISATION INTERNATIONALE DE NORMALISATION

---

## Earth-moving machinery — Method for locating the centre of gravity

*Engins de terrassement — Méthode de repérage du centre de gravité*

First edition — 1977-12-15

---

UDC 621.879 : 531.24

Ref. No. ISO 5005-1977 (E)

**Descriptors :** earth-handling equipment, physical tests, determination, stability, centre of gravity.

Price based on 6 pages

## FOREWORD

ISO (the International Organization for Standardization) is a worldwide federation of national standards institutes (ISO member bodies). The work of developing International Standards is carried out through ISO technical committees. Every member body interested in a subject for which a technical committee has been set up has the right to be represented on that committee. International organizations, governmental and non-governmental, in liaison with ISO, also take part in the work.

Draft International Standards adopted by the technical committees are circulated to the member bodies for approval before their acceptance as International Standards by the ISO Council.

International Standard ISO 5005 was developed by Technical Committee ISO/TC 127, *Earth-moving machinery*, and was circulated to the member bodies in June 1976.

It has been approved by the member bodies of the following countries :

Austria	Germany	South Africa, Rep. of
Brazil	Italy	Spain
Bulgaria	Japan	Sweden
Canada	Korea, Rep. of	Turkey
Chile	Mexico	United Kingdom
Czechoslovakia	Philippines	U.S.A.
Finland	Poland	U.S.S.R.
France	Romania	Yugoslavia

No member body expressed disapproval of the document.

# Earth-moving machinery – Method for locating the centre of gravity

## 0 INTRODUCTION

Although there are many possible methods of determining the centre of gravity, the intent of this International Standard is to specify one simple and practical method which requires the use of a weighbridge and crane.

There is no single fixed position of the centre of gravity of a machine which has attachments or components that are movable. When such a machine is tilted, as it must be to find the vertical co-ordinates, flexible parts deflect, fluids and loose parts move, and the position of the centre of gravity therefore changes. Again, particularly in the case of earth-moving machinery, the position of the centre of gravity will depend upon the nature and position of any attachments or ancillary equipment with which the item is fitted. It is therefore essential in all cases to state exactly the conditions of test.

## 1 SCOPE AND FIELD OF APPLICATION

This International Standard specifies a method for determining the co-ordinates of the centre of gravity of earth-moving machinery such as tractors, loaders, dumpers and graders in any condition of loading or position of attachments.

## 2 DEFINITIONS

For the purpose of this International Standard the following definitions apply :

**2.1 machine :** The machine or other object whose centre of gravity is to be determined.

**2.2 apparatus :** The equipment required to determine the centre of gravity of a machine.

**2.3 attachment :** A piece of equipment which is available for mounting on the machine for a particular purpose (for example a bulldozer blade, winch or bucket).

**2.4 "left-hand" and "right-hand" sides :** These terms apply when facing in the primary direction of travel.

**2.5 mass :** The mass of the machine as submitted for test.

## 3 PREPARATION AND LOADING OF MACHINE

The machine shall be clean and shall be tested in normal working conditions or in a specified condition agreed between the manufacturer and the testing authority.

**3.1 Radiator, sump, hydraulic and other reservoirs,** shall be filled to specified working levels; the fuel tank shall be full or empty or in a specified condition as agreed between the manufacturer and testing authority.

**3.2 Tools, spare tyre, and loose accessories and equipment** shall be complete as supplied and shall be in the normal stowage positions.

**3.3 Tyre pressures** shall be as specified in the manufacturer's operating instructions or, if a range of pressures is allowed, at the highest pressure recommended. In the case of machines fitted with hydro-inflation tyres they shall be filled in accordance with the manufacturer's operating instructions.

**3.4 The attachment** shall be normally put in the operating position; for example :

a) for crawler or wheeled tractors, with the dozer equipment lowered, tilt adjustment horizontal, to the lowest possible position just clear of the horizontal reference plane (see 5.3);

b) for loaders with the bucket fully crowded back and the front linkage in such a position that the lower part of it or the bucket is just clear of the horizontal reference plane;

c) for graders with the cutting edge of the blade horizontal and perpendicular to the horizontal axis of the machine and 20 cm above the horizontal reference plane. The front wheels shall be vertical.

The centre of gravity may be determined in a similar manner with the attachment(s) in many different positions and the co-ordinates for these different positions recorded as indicated in the report table at 6.4.

**3.5 Articulated machines** will normally be tested locked in a straight line, but the test may be required to be conducted with the joint set at the maximum or any intermediate angle.

3.6 When a scribing board is required it shall be at least 600 mm (24 in) high by 450 mm (18 in) wide, rigidly constructed, and attached to the machine in a suitable position with a smooth face vertical and parallel to the side or other appropriate plane (see clause 6).

#### 4 METHOD OF DETERMINATION

##### 4.1 Principle

The suspension and ground reaction method is used. This method involves measuring the ground reactions with the machine under test first level and second tilted in the fore-and-aft direction. The calculated horizontal distance of the centre of gravity from a ground contact point is measured in each case and verticals drawn on a scribing board affixed to the machine. The intersection of the verticals (which in practice forms a small triangle) indicates the centre of gravity, the exact position being taken at the intersection of the medians.

##### 4.2 Apparatus

The following apparatus is suggested :

4.2.1 Weighbridge, calibrated, for example  $\times 20$  kg (44 lb).

4.2.2 Crane.

4.2.3 Decking.

4.2.4 Knife edges (conveniently sized rolled steel angle).

4.2.5 Level

4.2.6 Plumb rule

4.2.7 Squares

} conveniently combined in a field level.

4.2.8 Scribing board.

4.2.9 Marking materials.

4.2.10 Tape measure.

##### 4.3 Procedure

The horizontal fore-and-aft co-ordinate, the lateral co-ordinate in the horizontal plane and the vertical co-ordinate of the centre of gravity shall be determined as stated in 4.3.1 to 4.3.3.

##### 4.3.1 Horizontal fore-and-aft co-ordinate, $\bar{x}$

###### 4.3.1.1 TRACKED MACHINE (see figure 1)

Measure  $M$ , the mass of the whole machine, on the weighbridge.

Measure  $r$ , the reaction under the knife edge due to its mass and part of the decking.

Move the machine on to the decking part supported by the weighbridge and measure  $R + r$ .

Measure  $P$ , the distance between the knife edges. Calculate  $R$  by subtraction;

$$\text{then : } \bar{x} = \frac{R P}{M}$$

Using this calculated value of  $\bar{x}$ , draw a perpendicular through the centre of gravity on the scribing board affixed to the machine. Then refer  $\bar{x}$  to the appropriate reference plane in accordance with clause 5.

###### 4.3.1.2 WHEELED MACHINES

With wheeled machines it is not necessary to use decking or knife edges. With brakes off, measure axle loads and calculate  $\bar{x}$ , from the pitch of the axles. Then refer  $\bar{x}$  to the appropriate reference plane in accordance with clause 5.

##### 4.3.2 Lateral co-ordinate in the horizontal plane, $\bar{y}$ (see figure 2)

Measure left-hand  $R_1$  and right-hand  $R_2$  wheels or track loadings. Calculate offset of centre of gravity using track gauge or wheel track as the moment arm.

$$b = \frac{R_2 \text{ (gauge)}}{M}$$

$$\bar{y} = \frac{\text{gauge}}{2} - b$$

NOTE — It will usually be found that the right-hand and left-hand side loads do not total the mass of the machine exactly due to small differences in level between the weighbridge deck and the surround. Any error is minimized by equalizing the overlap of the side being weighed in both cases.

It is preferable to use the total right-hand side and left-hand side wheel (track) loadings to determine the mass of the machine  $M$ .

Then refer  $\bar{y}$  to the appropriate reference plane in accordance with clause 5.

##### 4.3.3 Vertical co-ordinate of the centre of gravity, $\bar{h}$ (see figure 3)

4.3.3.1 Suspend the machine under test from one end at an angle of  $15^\circ$  to  $25^\circ$  from the horizontal, the other end resting on the weighbridge. The maximum convenient angle should be employed. The method is applicable either to wheeled or tracked machines, the main difference being in establishing the exact location of the point of application of the ground reaction, i.e. the ground contact. In wheeled machines, which shall be unbraked, this is vertically below the axle. In tracked machines, it is necessary to manoeuvre until the contact-grousers are in line  $BB'$  on either side or to make contact through a length of angle iron set on line  $BB'$ . In all cases the suspension cable shall be vertical in both planes as tested by plumb rule. This is an essential condition to ensure that the ground reactions in the horizontal plane are zero.

**4.3.3.2** Measure  $R$ , the reaction at the ground contact on the weighbridge.

**4.3.3.3** Measure  $d$ , the horizontal distance from the ground contact to the line of suspension.

**4.3.3.4** Calculate  $c$ , the horizontal distance from the centre of gravity to the line of suspension, from the formula

$$c = \frac{R d}{M}$$

**4.3.3.5** Draw the vertical through the centre of gravity on the scribing board fixed to the machine.

Repeat with machine suspended from the other end. The suspension angle need not be the same for both ends.

The intersection of the verticals on the scribing board gives the position of the height of the centre of gravity  $\bar{h}$ . Refer this to the appropriate reference plane in accordance with clause 5.

**NOTE** — The machine may be conveniently run on the the weigh-bridge, square, using chalked lines. This will assist in drawing the plan. If, with tracked machines, the grousers are not in line at B and B' (see figure 3) it is necessary to resort to trial and error by running the machine in varying circles till the required result is attained at the last approach.

## 5 REFERENCE PLANES

The reference planes may conveniently be taken as follows :

**5.1 Vertical 1** : Through the driving sprocket axle if for a crawler tractor but through the front axle, or front idler

centres, if a crawler or wheeled shovel as this is an important datum used in design.

**5.2 Vertical 2** : Through the major fore-and-aft axis of a machine, i.e. midway between the wheels or tracks.

**5.3 Horizontal** : Ground level. A hard contact shall be assumed, i.e. no grouser penetration in the case of a tracked machine.

## 6 REPORTING OF RESULTS

**6.1** The report shall give the co-ordinates of the centre of gravity :

$\bar{x}$ , horizontal fore-and-aft co-ordinate, being the distance from vertical 1;

$\bar{y}$ , lateral co-ordinate or displacement from the vertical 2; positive to the right, negative to the left;

$\bar{h}$ , vertical co-ordinate or height above the horizontal ground level.

**6.2** The position of the centre of gravity shall be reported in millimetres to the nearest 10 mm from three reference planes. The reference planes, if other than those given in clause 5, shall be stated.

**6.3** All details relevant to the position of the centre of gravity of the machine shall be reported (see clause 3). Details and positioning of attachment(s) and loading shall be stated.

**6.4** A suggested form of report is shown on page 4.

Manufacturer's name .....			Model .....				
Machine type .....			Chassis No. .... Engine No. ....				
Serial No. ....			Tyre pressures Front. .... kPa (lbf/in <sup>2</sup> )				
Attachments .....			Rear .... kPa (lbf/in <sup>2</sup> )				
Date of test. ....							
Machine mass <i>M</i>		Unladen	Laden				
		..... kg (lb)	..... kg (lb)				
Left-hand side							
Right-hand side							
Total							
Co-ordinates of centre of gravity, mm							
Position of attachment(s)		$\bar{x}$	$\pm \bar{y}$	$\bar{h}$	$\bar{x}$	$\pm \bar{y}$	$\bar{h}$

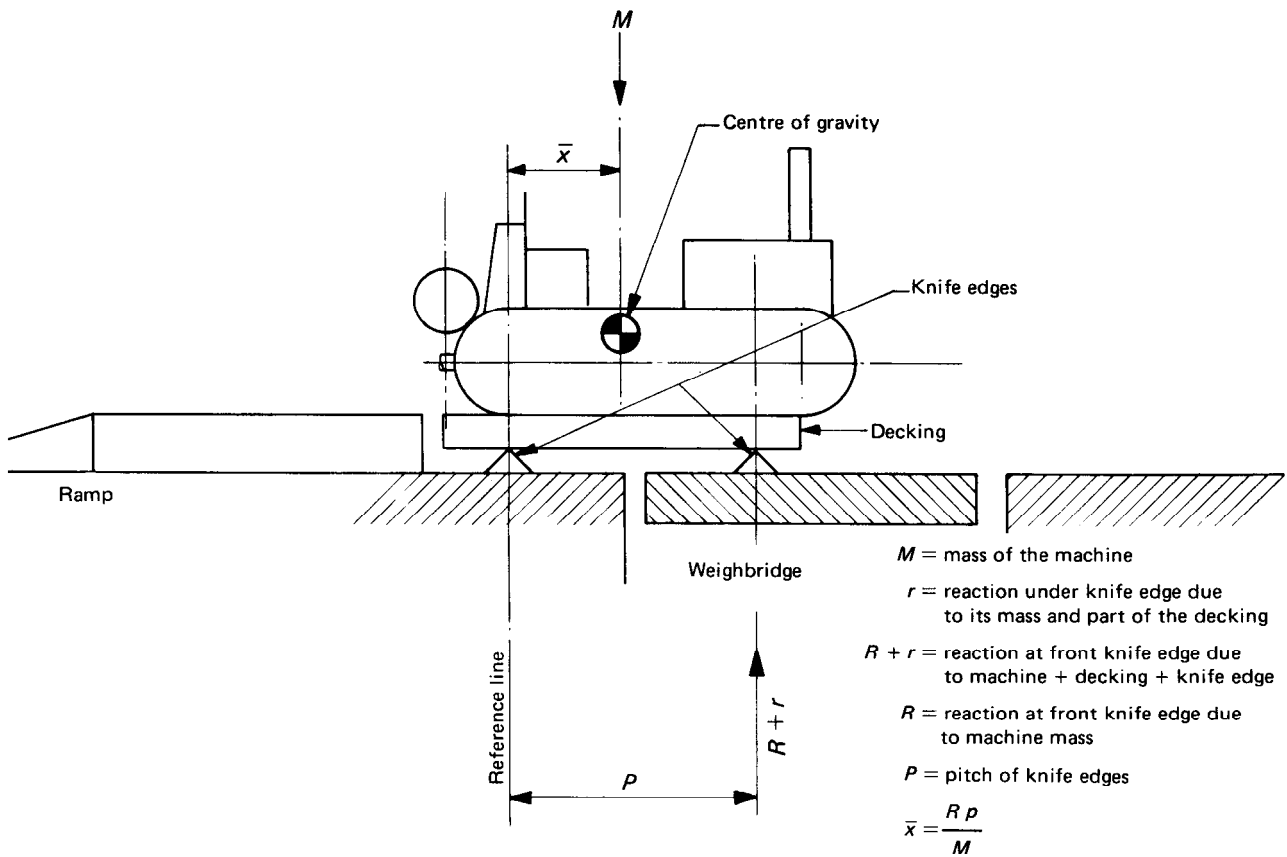

FIGURE 1 — Determination of the fore-and-aft co-ordinate,  $\bar{x}$

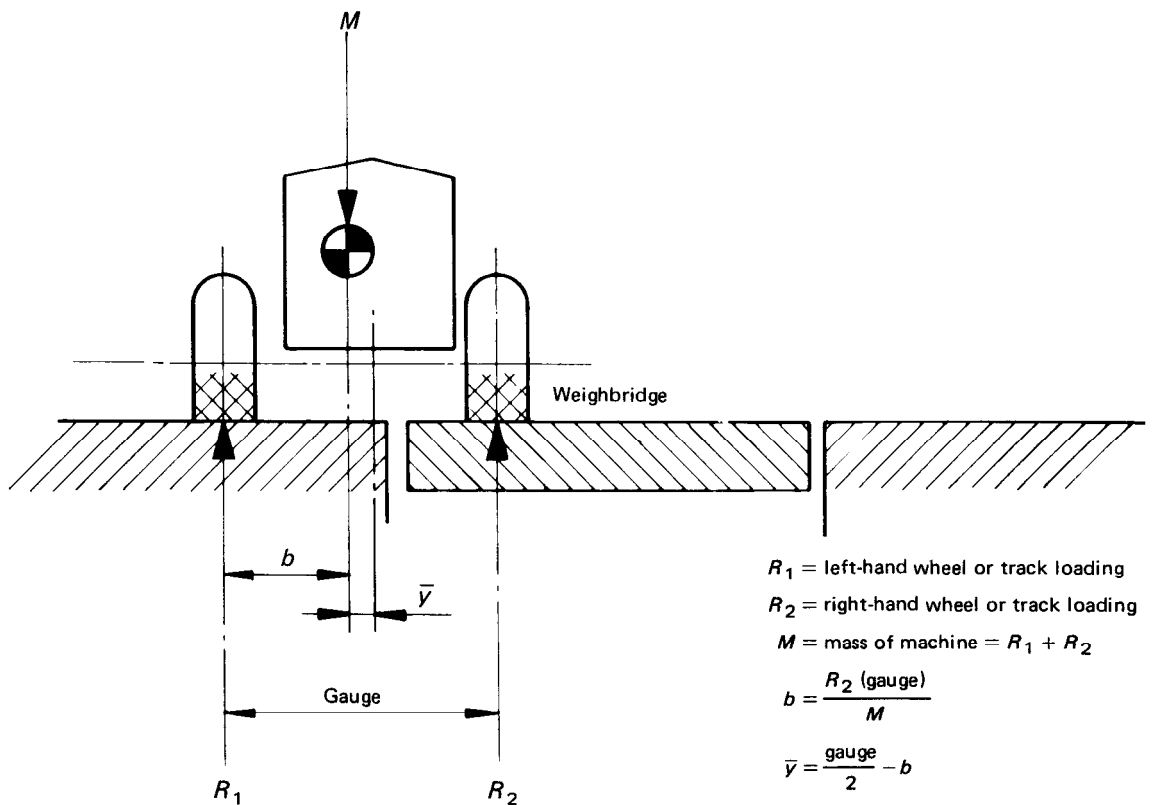
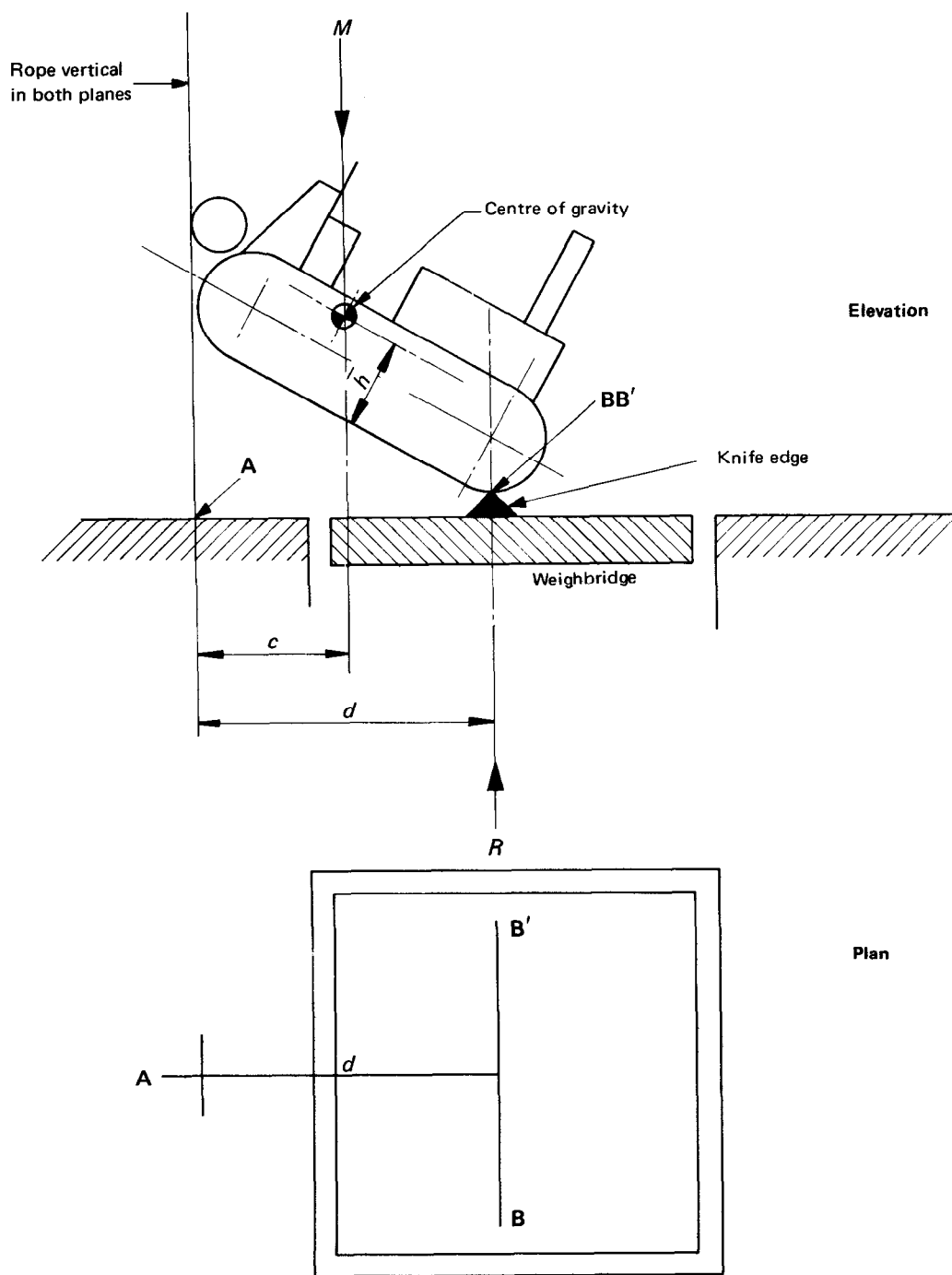

FIGURE 2 — Determination of lateral co-ordinate in the horizontal plane,  $\bar{y}$



$M$  = mass of machine

$R$  = reaction under ground contact on weighbridge

$d$  = horizontal distance of the ground contact from the line of suspension

$c$  = horizontal distance of the centre of gravity from the line of suspension

$A$  = point of intersection of perpendicular from line of suspension and ground

$BB'$  = line of ground contact

$\bar{h}$  = height of centre of gravity above ground level

$$c = \frac{R d}{M}$$

FIGURE 3 – Determination of vertical co-ordinate of the centre of gravity,  $\bar{h}$