

INTERNATIONAL STANDARD

ISO
4902

Second edition
1989-12-01

Information technology — Data communication — 37-pole DTE/DCE interface connector and contact number assignments

*Technologies de l'information — Communication de données — Connecteur
d'interface ETTD/ETCD à 37 pôles et affectation des numéros de contact*



Reference number
ISO 4902 : 1989 (E)

Foreword

ISO (the International Organization for Standardization) is a worldwide federation of national standards bodies (ISO member bodies). The work of preparing International Standards is normally carried out through ISO technical committees. Each member body interested in a subject for which a technical committee has been established has the right to be represented on that committee. International organizations, governmental and non-governmental, in liaison with ISO, also take part in the work. ISO collaborates closely with the International Electrotechnical Commission (IEC) on all matters of electrotechnical standardization.

Draft International Standards adopted by the technical committees are circulated to the member bodies for approval before their acceptance as International Standards by the ISO Council. They are approved in accordance with ISO procedures requiring at least 75 % approval by the member bodies voting.

International Standard ISO 4902 was prepared by Technical Committee ISO/TC 97, *Information processing systems*.

This second edition cancels and replaces the first edition (ISO 4902 : 1980), of which it constitutes a minor revision: certain terms have been aligned with the terms and definitions used by IEC.

Annexes A, B and C of this International Standard are for information only.

Information technology — Data communication — 37-pole DTE/DCE interface connector and contact number assignments

1 Scope

This International Standard specifies the 37-pole connector and the assignment of contact numbers at the interface between data terminal equipment (DTE) and data circuit-terminating equipment (DCE) where CCITT¹⁾ Recommendation V.24 together with Recommendations V.10 and V.11 are applicable.

International Standard ISO 4902 additionally provides the dimensions of the connector housing, as well as the recommended means of providing a locking device (latching block) and connector shielding.

2 Normative references

The following standards contain provisions which, through reference in this text, constitute provisions of this International Standard. At the time of publication, the editions indicated were valid. All standards are subject to revision, and parties to agreements based on this International Standard are encouraged to investigate the possibility of applying the most recent editions of the standards listed below. Members of IEC and ISO maintain registers of currently valid International Standards.

ISO 261 : 1973, *ISO general purpose metric screw threads — General plan.*

ISO 2110 : 1980, *Data communication — 25-pin DTE/DCE interface connector and pin assignments.*

ISO 4903 : 1980, *Data communication — 15-pin DTE/DCE interface connector and pin assignments.*

CCITT Recommendation V.10 (or X.26) : 1989, *Electrical characteristics for unbalanced double-current interchange circuits for general use with integrated circuit equipment in the field of data communications.*

CCITT Recommendation V.11 (or X.27) : 1989, *Electrical characteristics for balanced double-current interchange circuits for general use with integrated circuit equipment in the field of data communications.*

CCITT Recommendation V.24 : 1989, *List of definitions for interchange circuits between data terminal equipment (DTE) and data circuit-terminating equipment (DCE).*

CCITT Recommendation V.28 : 1989, *Electrical characteristics for unbalanced double-current interchange circuits.*

CCITT Recommendation V.36 : 1989, *Modems for synchronous data transmission using 60-108 kHz group band circuits.*

CCITT Recommendation V.37 : 1989, *Synchronous data transmission at a data signalling rate higher than 72 kbit/s using 60-108 kHz group band circuits.*

IEC Publication 50(581) : 1978, *International Electrotechnical Vocabulary — Chapter 581 : Electromechanical components for electronic equipment.*

IEC Publication 807-2 : 1985, *Rectangular connectors for frequencies below 3 MHz — Part 2: Detail specification for a range of connectors with round contacts — Fixed solder contact types.*

3 Definitions

The following definitions have been taken from IEC Publication 50(581) : 1978.

3.1 cable adaptor: A part of a connector or an accessory consisting of a rigid housing for attachment to the connector body. It may incorporate provision for a cable clamp or seal for terminating screens and provide shielding from electrical interference. It may be straight or angled.

3.2 connector housing: A part of a connector into which the insert and contacts are assembled.

3.3 contact arrangement: The number, spacing and configuration of contacts in a component.

3.4 female contact: A contact intended to make electrical engagement on its inner surface and which will accept entry of a male contact.

3.5 intermateable connectors: Two connectors are intermateable when they are capable of being connected electrically and mechanically but without regard to their performance and intermountability.

1) International Telegraph and Telephone Consultative Committee.

3.6 locking device: A feature incorporated in certain components to provide mechanical retention of their mating part.

3.7 male contact: A contact intended to make electrical engagement on its outer surface and which will enter a female contact.

3.8 (n-pole-)connector: A component which terminates conductors for the purpose of providing connection and disconnection to a suitable mating component.

4 Connector

Figures 1 to 5 illustrate the 37-pole connector. Only those dimensions that are essential to mating are shown.

Figure 1 illustrates the DTE connector which has 37 male contacts in a connector housing. Figure 2 illustrates the DCE connector which has 37 female contacts in a connector housing. The connector housing on the DCE connector is dimensioned to fit inside the connector housing on the DTE connector (see figures 1 and 2). Contact numbering is specified in figures 1 and 2. Figure 3 illustrates the dimensions for the contact spacing. Figures 4 and 5 illustrate the dimensions for the male and female contacts respectively.

The DCE connector shall be equipped with a locking device consisting of two latching blocks as specified in figure 2. Due to the fact that the latching blocks have threaded holes which can act as nuts, the DTE connector may be equipped either with lever devices for latching to the latching blocks on the DCE connector or with screws that fit into the threaded holes in the latching blocks.

The thread of the latching blocks shall be M3 as specified in figure 2.

Sufficient connector dimensions are provided in this International Standard to ensure intermateable connectors. They are consistent with the detailed connector specification in IEC Publication 807-2.

In annex A, diagrams for finger clearance areas are given to provide guidance for equipment designers. Figure A.1 shows the maximum DTE connector outline including all means for latching to the latching blocks. Figure A.2 shows the minimum DCE connector spacing when multiple interface arrangements are used.

5 Assignment of contact numbers

The assignment of contact numbers for the selected interchange circuits specified in CCITT Recommendation V.24 that may be implemented in modems complying with CCITT Recommendations V.36 and V.37 is given in table 1. Although table 1 provides the total list of interchange circuits designated in all the above listed modem CCITT Recommendations, only those interchange circuits required for the particular equipment need to be implemented. Table 2 shows the preferred assignments of circuits which may be applied for national use. Table 3 gives a list of the applicable interchange circuits used in tables 1 and 2 and their description. Additionally, notes 5 and 6 to table 1 provide preferred assignment of contact numbers for some optional circuits which may be applied for national use.

6 Connector shielding

Connector shielding is optional. If it is used, for example due to national regulations, etc., it shall be accomplished by the use of metallic connector housings on both the DTE connector and the DCE connector.

7 Interconnecting configurations for mixed use of V.10, V.11 and V.28 electrical characteristics

Considerations for the interworking of equipment implementing V.10 on one side of the interface with equipment implementing V.11 on the other side of the interface are given in annex A, clause A.2 of CCITT Recommendations V.10 and V.11. In addition, the definition of the category 1 and 2 receiver configurations is provided in V.10.

Guidance concerning possible interconnecting configurations applicable to V.28 interfaces is provided in annex B.

Guidance concerning the necessary adaptation when there is a need for a DTE or DCE implementing V.10 characteristics to interwork with a DCE or DTE implementing V.28 characteristics is given in annex C. Any adapters required to accomplish the interworking with V.28 and ISO 2110 shall be provided with equipment meeting the requirements of this International Standard. No revisions or modifications shall be required in the existing equipment using V.28 electrical characteristics.

The annex C interworking between V.10 and V.28 characteristics is not required in CCITT Recommendations V.36 and V.37.

Table 1 — Assignment of contact numbers

First segment assignment ²⁾			Second segment assignment ²⁾			Receiver category ⁴⁾	Direction to	
Contact number	Circuit number	Interchange points ³⁾	Contact number	Circuit number	Interchange points		DTE	DCE
1	1)					—	—	—
2	N	A-A'	20	102b	C-B'	2	X	
3	N	A-A'	21	N	B/C-B'	1	X	
4	103	A-A'	22	103	B/C-B'	1		X
5	114	A-A'	23	114	B/C-B'	1	X	
6	104	A-A'	24	104	B/C-B'	1	X	
7	105	A-A'	25	105	B/C-B'	1		X
8	115	A-A'	26	115	B/C-B'	1	X	
9	106	A-A'	27	106	B/C-B'	1	X	
10	141	A-A'	28	N	A-A'	2		X
11	107	A-A'	29	107	B/C-B'	1	X	
12	108*	A-A'	30	108*	B/C-B'	1	X	
13	109	A-A'	31	109	B/C-B'	1	X	
14	140	A-A'	32	N	A-A'	2		X
15	N	A-A'	33	N	A-A'	2	X	
16	111	A-A'	34	N	A-A'	2		X
17	113	A-A'	35	113	B/C-B'	1		X
18	142	A-A'	36	N	A-A'	2	X	
19	102	C-C'	37	102a	C-B'			X

Key: N — Contact permanently reserved for national use.

* — Circuit 108/1 or circuit 108/2 (if one of them is provided).

NOTES

1 Contact 1 is assigned for connecting the shields between tandem sections of the shielded interface cable. The shield may be connected either to protective ground or to signal ground at either the DTE or DCE or both in accordance with national regulations.

Signal ground may be further connected to protective ground in accordance with national safety regulations. Caution should be exercised to avoid establishment of ground loops carrying high currents.

2 The assignment of contact numbers for each segment has been aligned to specify pairing and connection to multipaired interconnecting cable. Each row of the table presents the respectively paired contacts, i.e. 2 and 20, 3 and 21, etc.

3 A, A', B, B', C and C' indicate the associated interchange points as designated in figure 2 of CCITT Recommendations V.10 and V.11. Where B/C is indicated in table 1, the B designation applies only when a V.11 generator is used and the C designation applies only when a V.10 generator is used (see annex B).

4 The receiver categories are as designated in V.10. Where category 1 receivers apply, either V.10 or V.11 generators may be used. Only V.11 generators may be used for circuits 103, 104, 113, 114, 115. Where category 2 receivers apply, V.10 generators are used.

Table 2 — Preferred assignment of contact numbers of circuits for national use

Contact number	Circuit number	Description
2	112	Data signalling rate selector (DCE source)
15	125	Calling indicator
33	110	Data signal quality detector
34	136	New signal
3/21	128	Receiver signal element timing (DCE source)

Table 3 — List of interchange circuits

Circuit number	Description
102	Signal ground or common return
102a	DTE common return
102b	DCE common return
103	Transmitted data
104	Received data
105	Request to send
106	Ready for sending
107	Data set ready
108/1	Connect data set to line
108/2	Data terminal ready
109	Data channel received line signal detector
110	Data signal quality detector
111	Data signalling rate selector (DTE source)
112	Data signalling rate selector (DCE source)
113	Transmitter signal element timing (DTE source)
114	Transmitter signal element timing (DCE source)
115	Receiver signal element timing (DCE source)
125	Calling indicator
128	Receiver signal element timing (DTE source)
136	New signal
140	Loopback/Maintenance test
141	Local loopback
142	Test indicator

Dimensions in millimetres

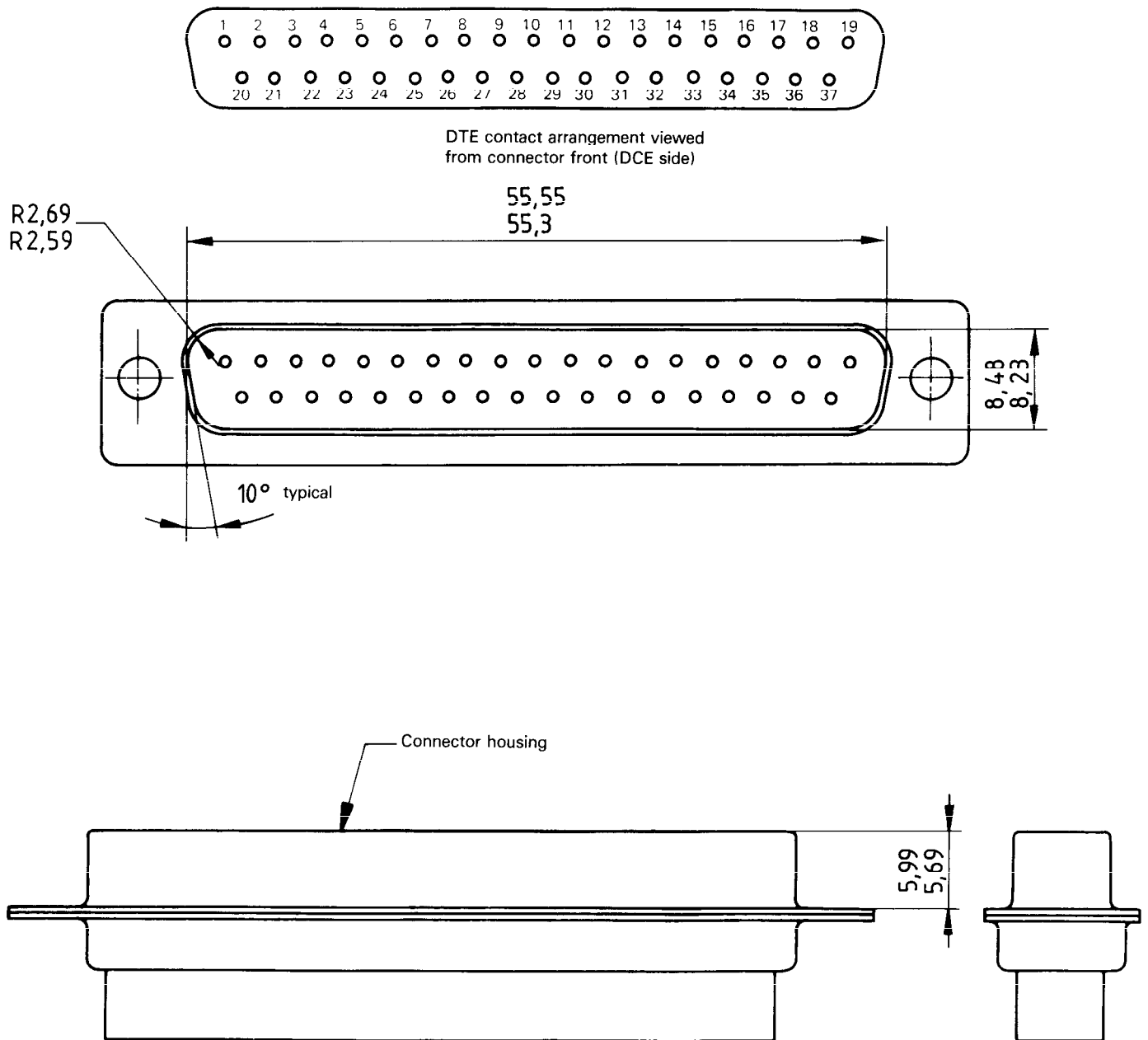

Figure 1 – DTE connector

Dimensions in millimetres

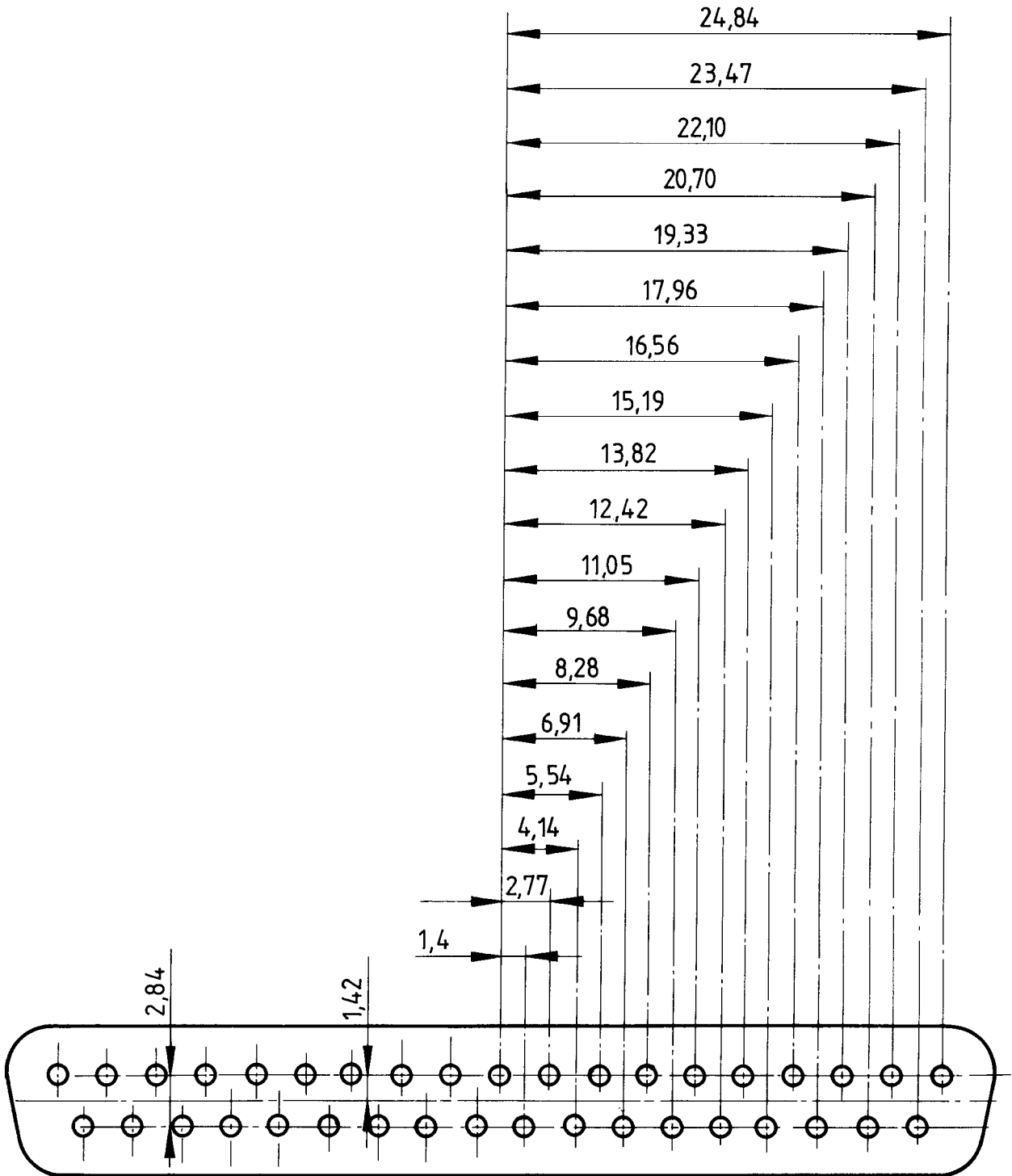

Figure 3 — Contact spacing dimensions

Dimensions in millimetres

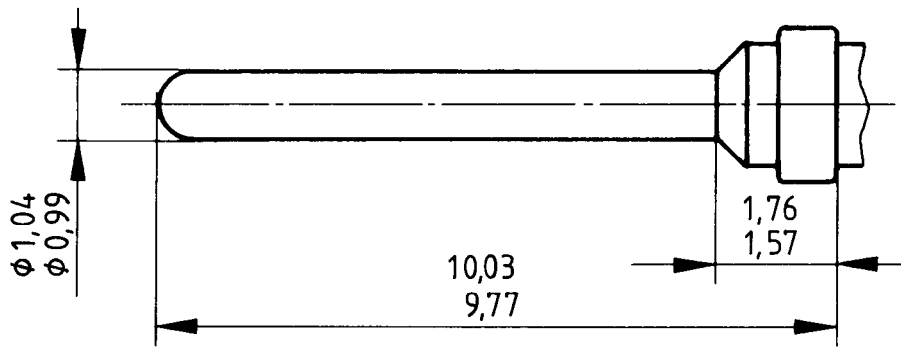
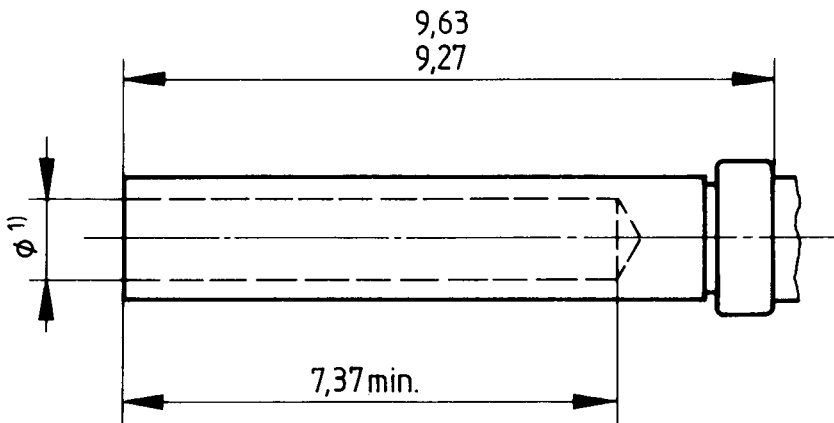

Figure 4 — Male contact

Dimensions in millimetres



1) When the male contact is mated with the female contact, sufficient force should be applied by the female contact to ensure proper electrical contact.

Figure 5 — Female contact

Annex A
(informative)

Diagrams for finger clearance

This annex provides guidance on finger clearance for equipment designers.

Figure A.1 shows the maximum DTE connector outline.

Figure A.2 shows the minimum recommended spacing between multiple DCE connectors, taking into account the various locking devices (levers, screws) of DTE connectors.

Dimensions in millimetres

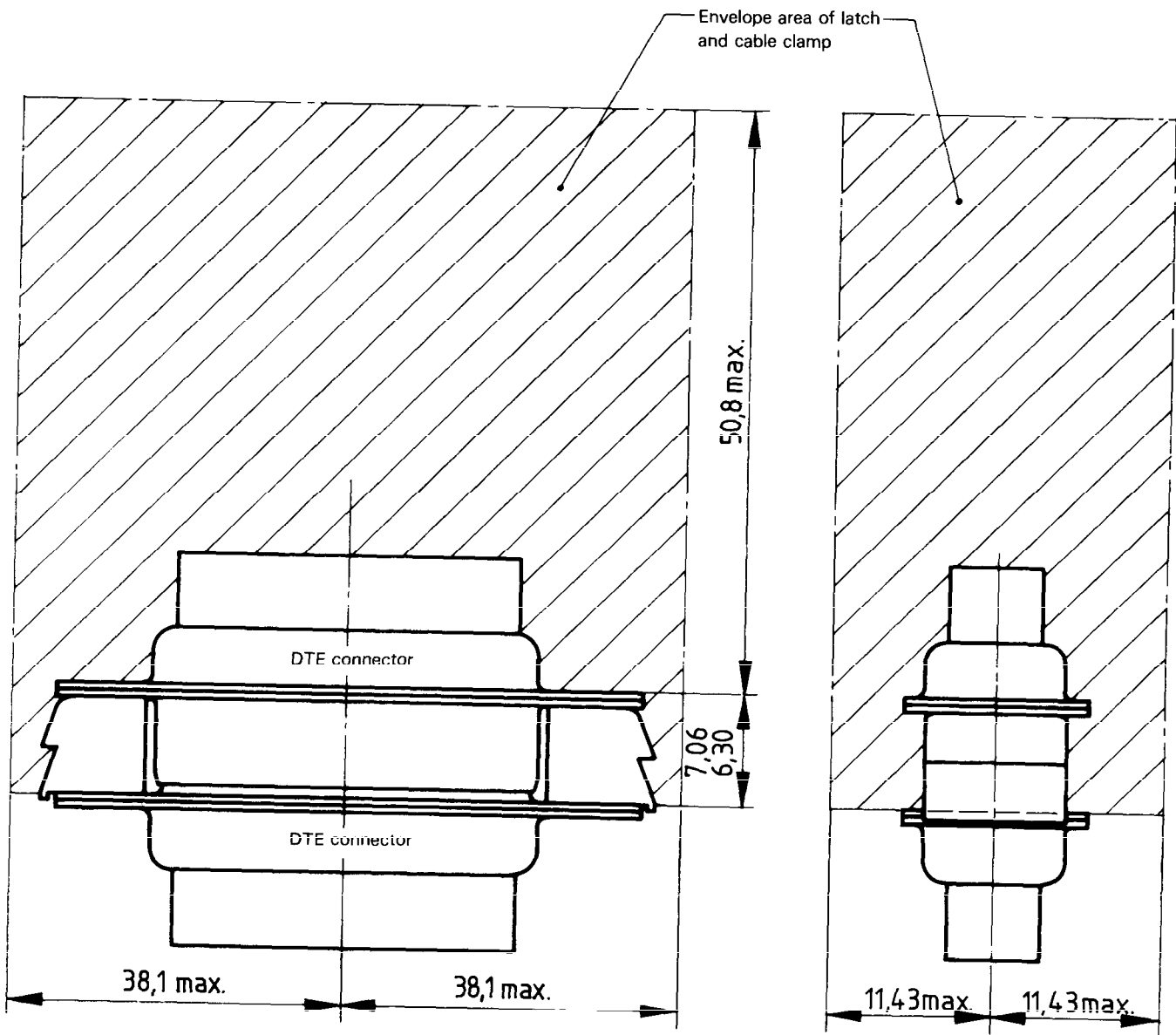

Figure A.1 – Maximum DTE connector outline

Dimensions in millimetres

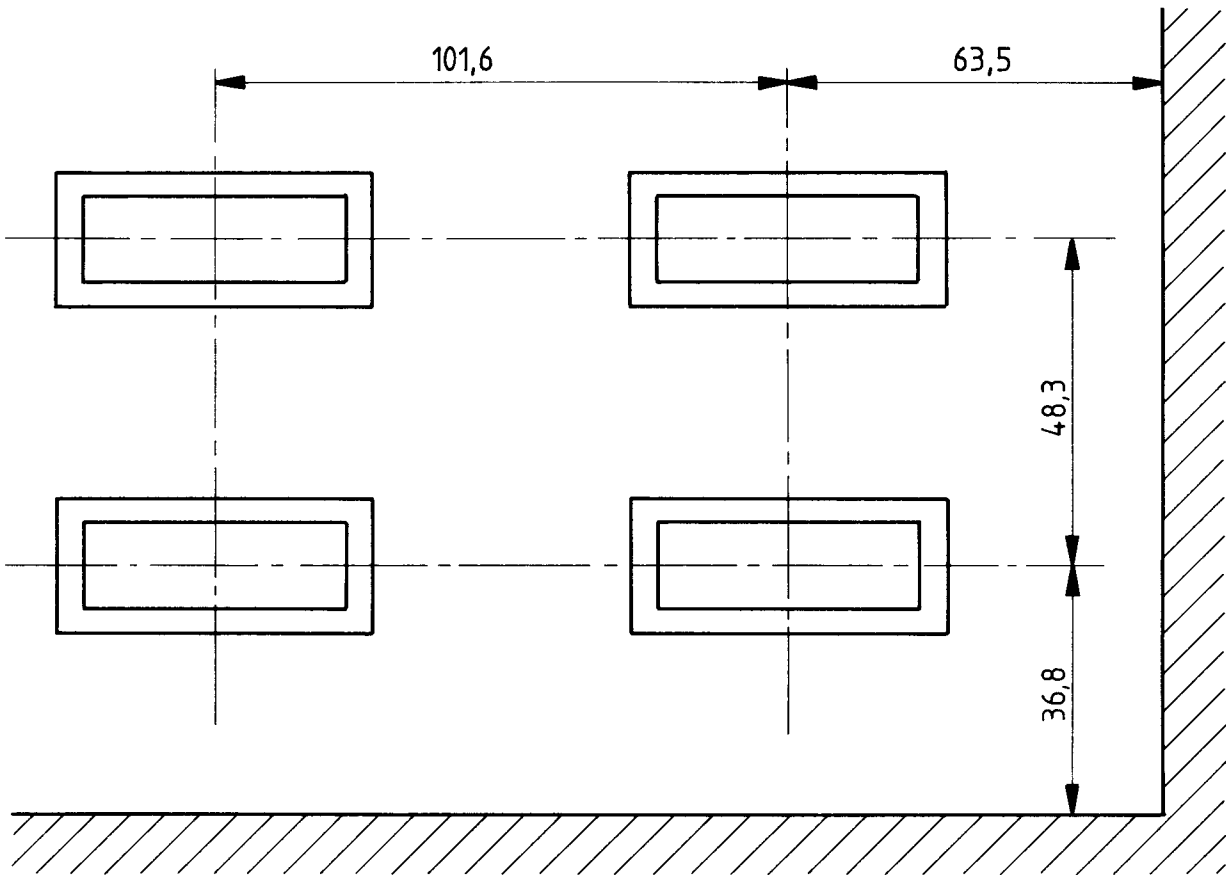

Figure A.2 – Minimum DCE connector spacing

Annex B (informative)

Generator/receiver interconnecting configurations

CCITT Recommendation V.10 defines the two basic receiver configurations. Category 1 receivers have both the A and B interface points accessible through the interface connector. Category 2 receivers have only the individual A' interface points accessible through the interface connector with all B' points connected together within the equipment and brought to a

single common return circuit through the interface connector. The category 1 receiver configuration can be interconnected with either balanced V.11 or unbalanced V.10 generators. The category 2 receiver configuration is only intended for interconnection with V.10 generators. Figure B.1 illustrates three possible interconnecting configurations that may be applied.

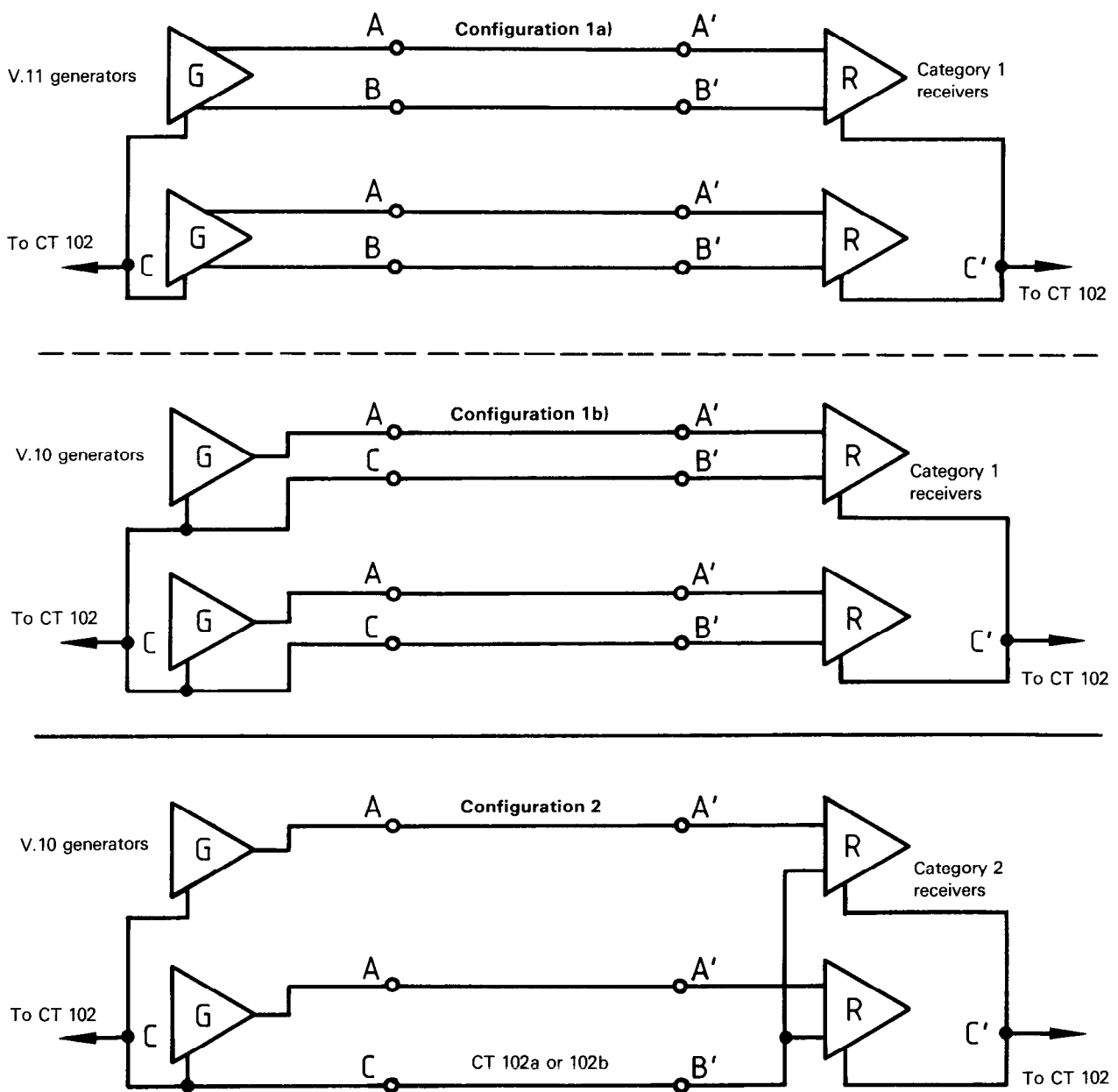

Figure B.1 – Generator/receiver interconnecting configurations

Annex C (informative)

Interworking requirements with V.28 circuits

C.1 Scope

This annex applies to DTE and DCE which implement V.10 electrical characteristics on all interchange circuits. The necessary adaptation is described to provide compatible interworking of V.10/ISO 4902 equipment with V.28/ISO 2110 equipment. The adaptation is associated solely with the V.10/ISO 4902 equipment so that no retrofits or modifications are necessary for V.28/ISO 2110 equipment.

C.2 Electrical characteristics

This clause describes the necessary adaptation of equipment designed for V.10 characteristics to make it closely resemble the V.28 characteristics. An overlap in values of parameters of V.10 and V.28 has been established such that additional provisions incorporated in the interface circuits using V.10 will make the necessary adjustments to ensure proper operation with V.28 circuits. It should be noted that the performance associated with interworking V.10 circuits with V.28 circuits is limited to that normally associated with V.28 operation.

C.2.1 Protection

V.10 states that the receivers shall not be damaged by voltages up to 12 V while V.28 generators may produce output voltages up to 25 V. Although many commercially available V.10 receivers have been designed to withstand and operate properly with the higher V.28 voltages, protection will be necessary for those receivers which do not have sufficient tolerance. V.10 generators may also be damaged by the higher V.28 generator voltages if they are inadvertently interconnected or shorted together. Since the short circuit condition between V.28 and V.10 generators is purely a fault situation, any further consideration is left to the equipment designer.

C.2.2 Signal level

The generator output signal levels stated in V.10 and V.28 have an overlap in the 5 V to 6 V range. Furthermore, V.10 levels can be as low as 4 V while V.28 levels can be as high as 25 V. The considerations associated with the upper limit levels of V.28 generators operating with V.10 receivers have been covered in C.2.1. On the lower limit, although a V.10 generator output level between 4 V and 5 V is not within the V.28 recommendation, satisfactory operation with V.28 receivers having a 3 V transition margin can be expected because of the low source impedance of V.10 generators.

C.2.3 Risetime, data rate, distance

V.28 states that the risetime for the signal to pass through the ± 3 V transition region shall not exceed 3 % of the signal element duration. V.10, on the other hand, generally requires

much slower risetimes specified from 10 % to 90 % of the total signal amplitude to reduce cross talk for operation over longer distances. It is possible, however, through proper selection of the waveshaping for generators in V.10 equipment to meet the requirements of both V.10 and V.28 simultaneously for data signalling rates applicable to V.28 (i.e., up to 20 kbit/s).

In CCITT Recommendation V.10, a graph is provided of data signalling rate versus cable length. This graph has been translated in figure C.1 to show the relationships of risetime with data signalling rate and cable length. As a result, a clear picture is shown of the interactions between these parameters. Figure C.1 also illustrates the improved performance associated with linear waveshaping as contrasted with exponential waveshaping. It is expected that the more typical implementation will employ linear waveshaping. The abscissa of figure C.1 is the risetime of the signal from the V.10 generator. By reading up to the CABLE LENGTH curve and over to the left-hand ordinate scale, the associated maximum cable length can be determined. By reading up to the DATA SIGNALLING RATE curve and over to the right-hand ordinate scale, the associated maximum data signalling rate can be determined. Thus, for any specific risetime value both the maximum cable length and maximum data signalling rate can be determined. These values will ensure that the near-end cross talk levels stay below 1 V peak.

Figure C.2 shows the overlap in signal risetime characteristics which will allow interworking between V.10 generators and V.28 receivers. There are two sets of curves which represent selected data signalling rates. One set applies to signals with a linear risetime while the other set applies to signals with an exponential risetime. The right-hand limit of overlap of risetime between V.10 and V.28 is shown as 1 μ s for linear risetimes and 1,25 μ s for exponential risetimes. The former is based upon the 1 μ s limit on V.10 risetime and the latter is based upon the 15 m limitation generally associated with V.28 operation. This translates to a maximum possible data signalling rate greater than 20 kbit/s and thus permits interworking for all data signalling rates applicable to V.28 without the need for waveshaping options in the V.10 equipment.

In effect three parameters, risetime, generator output voltage (V_o), and data signalling rate, define the area of interworking between V.10 and V.28. This area of interworking is bounded by the 15 m V.28 distance limit line or the 1 μ s limit on V.10 risetime on the right side, the data signalling rate line on the left side, the 6 V V_o line on top, and the 4 V V_o line on the bottom.

C.2.4 Circuit failure conditions

A V.28 receiver designed to detect either a power-off condition or disconnection of the interconnecting cable will have no problem detecting these conditions when interworking with a V.10 generator. In the reverse situation, the V.28 recommendation

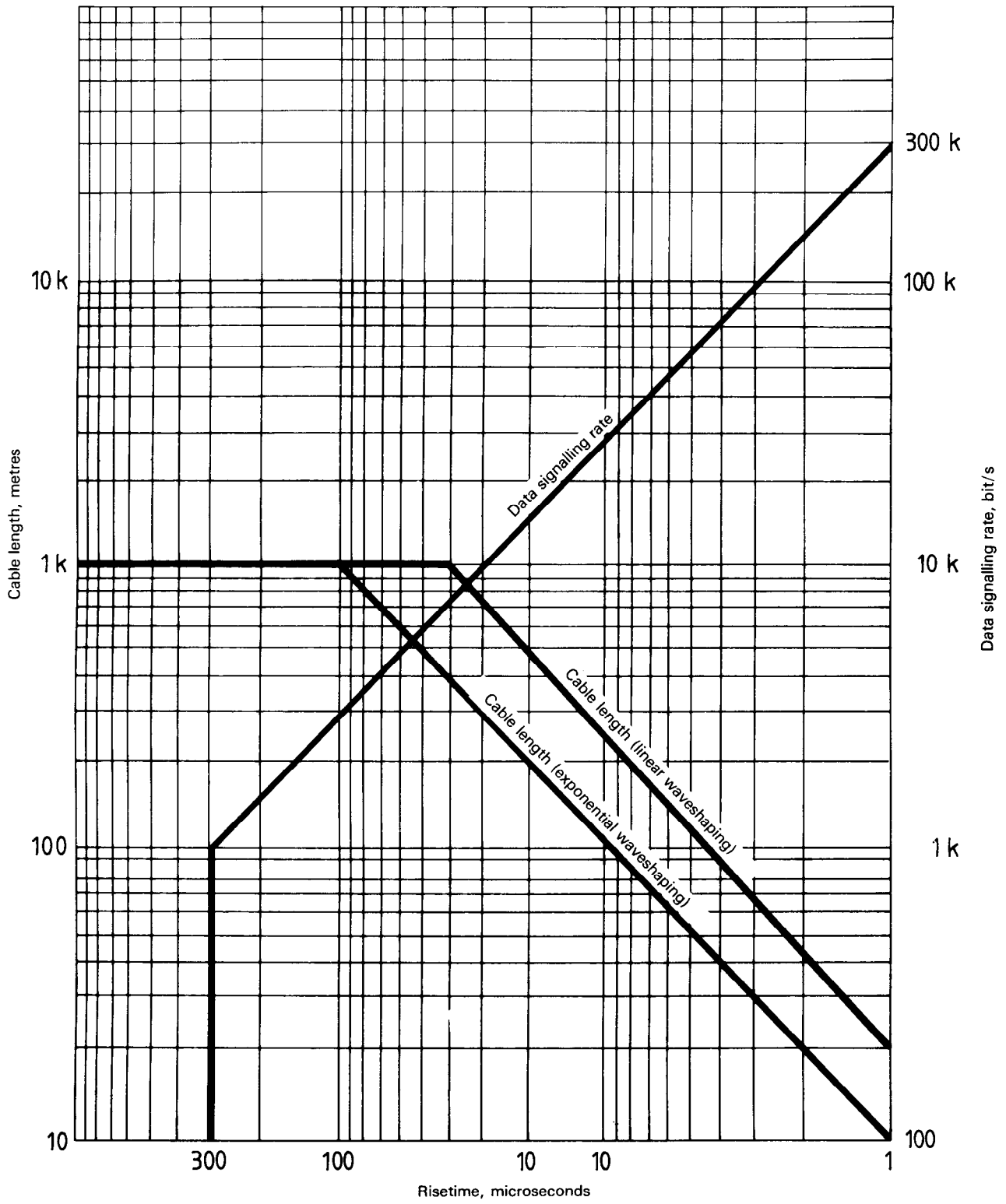

Figure C.1 – Data signalling rate and cable length versus risetime

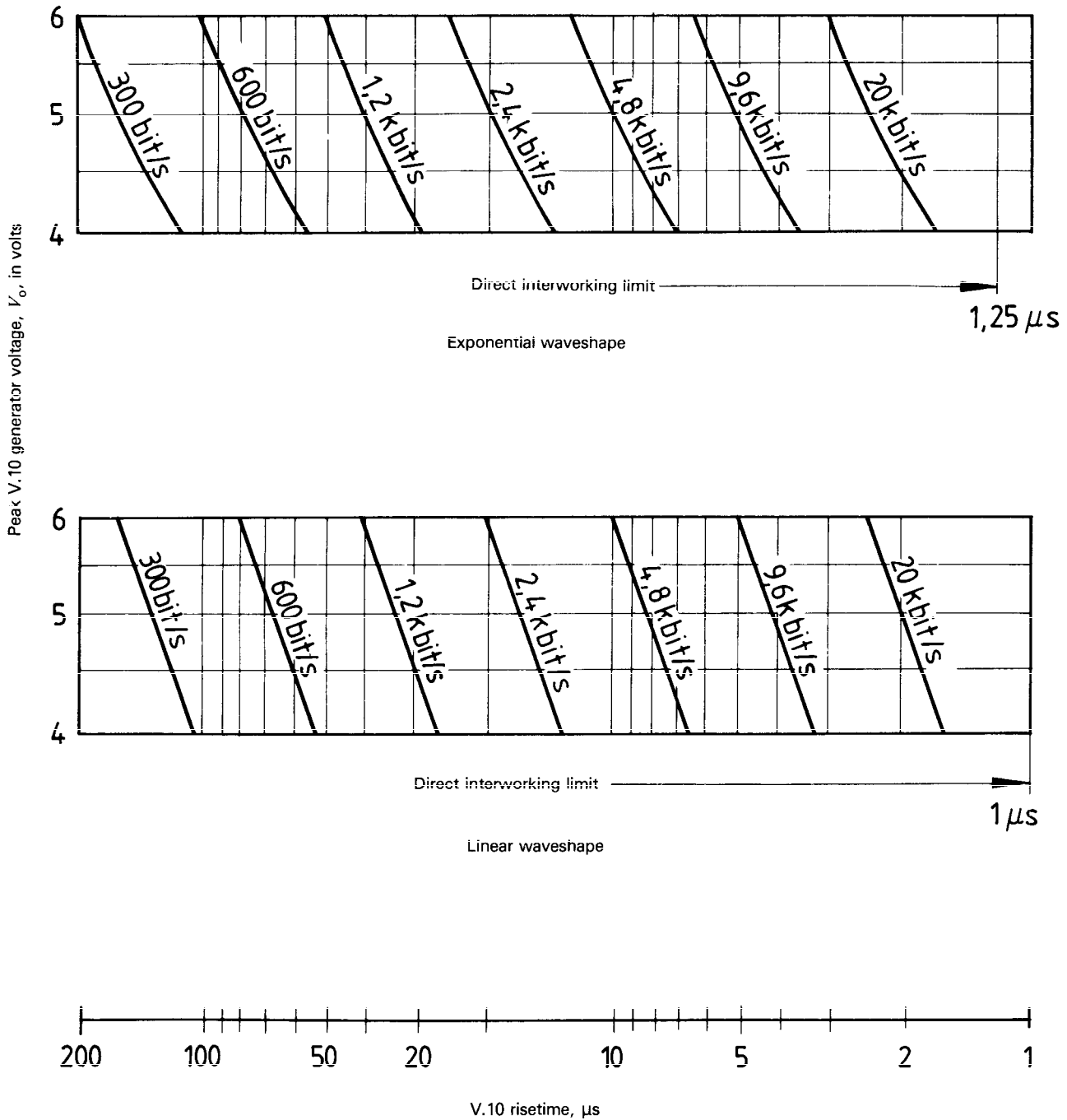

Figure C.2 – Risetime relationship to V.10/V.28 interworking

allows the generator impedance in the power-off condition to be as low as 300 Ω which is too low for fault detection by a V.10 receiver using the conventional voltage biasing method. As a result, it will be necessary to incorporate a minimum of 2 k Ω in series with the input to the V.10 receiver in order to ensure proper detection of these conditions when the conventional voltage biasing method is used.

C.2.5 Signal return

V.10 requires two signal return circuits, one for each direction of transmission, while V.28 requires only one. It is therefore necessary to connect signal returns 102a, 102b plus 102 of the V.10 equipment with circuit 102 of the V.28 equipment. Additionally, all B' interchange points of the category 2 receivers should also be connected to circuit 102 of the V.28 equipment.

C.3 Mechanical characteristics

ISO 2110 specifies the 25-pole DTE/DCE interface connector and assignment of contact numbers for V.28 equipment. V.10 equipment conforming to this International Standard uses a 37-pole DTE/DCE interface connector which belongs to the same family of connectors as the 25-pole connector. Therefore, mechanical adaptation is necessary for interworking between these two types of equipment. A 37/25-pole arrangement applies for all such interconnections.

C.4 Suggested implementation

The actual method of implementation for satisfying the provisions outlined in clauses C.2 and C.3 is not standardized because a number of innovative approaches are possible. Accordingly, it is left to the designer of equipment meeting the V.10 interface characteristics to incorporate the necessary provisions when interworking with V.28 equipment is desired as a special feature. It should not be assumed that any equipment meeting this International Standard and using all V.10 generators will interwork with V.28 equipment unless a specific reference is made that the requirements for interworking are fulfilled.

One method of satisfying the provisions outlined in clauses C.2 and C.3 has been developed. It is presented in this clause as guidance for implementing V.10 interface characteristics where interworking with V.28 equipment is essential.

C.4.1 Protection of V.10 receivers

Although V.10 states that receivers need only withstand 12 V without being damaged, a number of receiver integrated circuits are available that can withstand and operate properly with the higher voltages which are possible from V.28 generators. When the V.10 receivers do not have adequate tolerance, however, additional protection will be required. This can be accomplished by the addition of an attenuating L-pad in front of the V.10 receiver input as shown in figure C.3. The L-pad with a 2 k Ω series resistance and a 3,3 k Ω shunt resistance has an additional effect of appearing as a high impedance source. Therefore, the pad should be no further from the V.10 receiver inputs than 3 m of cable to ensure that near-end cross talk from adjacent circuits does not reach an unacceptable level (1 V peak).

C.4.2 Generator output signals

The V.10 generator signal risetime and output voltage should fall within the area of interworking defined in figure C.2.

C.4.3 Fault detection provisions

As specified earlier, a resistance of 2 k Ω in series with the input to the V.10 receiver is required for detection of the power-off condition if the receiver uses the biasing method. This additional resistance is not required, however, if the L-pad is included for receiver protection or if other methods are used for fault detection.

C.4.4 External adapter

A simple external adapter can be used to interconnect V.28 DTE and V.10 DCE and vice versa. Figure C.4 shows typical placements of adapters which provide necessary electrical and mechanical conversions.

The wiring diagrams of the basic 37/25-pole adapters are shown in figures C.5a) and C.5b).

Connections in addition to those shown in the wiring diagrams may be desirable for national circuits (N-contacts) or for circuits introduced in ISO 2110.

The L-pads which may be necessary for the V.10 receiver protection are also shown in figures C.5a) and C.5b). These pads can be easily implemented using 1/8 W resistors. The strapping of the signal return leads can also be accomplished in the adapters.

As pointed out earlier, the L-pads should be located within 3 m of cable from the V.10 receivers to avoid excessive near-end cross talk.

In the case of the V.28 DTE with V.10 DCE configuration, there is no problem since normally the connectors are located at the DCE. In the other configuration, V.10 DTE with V.28 DCE, placement of the adapter at the DCE would not be acceptable. It may therefore be necessary also to implement the 37-pole connector at the V.10 DTE to enable placement of the adapter within 3 m of cable from the V.10 DTE.

C.4.5 Summary of suggested provisions for V.10 equipment

- a) 37/25-pole mechanical adapter;
- b) generators implemented in accordance with V.10;
- c) V.10 generator signal risetime and output voltage selected within the area of interworking defined in figure C.2;
- d) L-pad attenuator, if needed, on appropriate circuits in adapter;
- e) connect signal common return circuits 102a and 102b together with circuit 102 and the receiver B' leads appearing at the interface from the V.10 equipment to circuit 102 from the V.28 equipment in the adapter;

f) when L-pad attenuators are used to protect the V.10 receivers, install adapter such that the cable length between the adapter and the V.10 equipment does not exceed 3 m;

g) total cable length between the V.10 equipment and the V.28 equipment is limited to the length normally associated with V.28 operation.

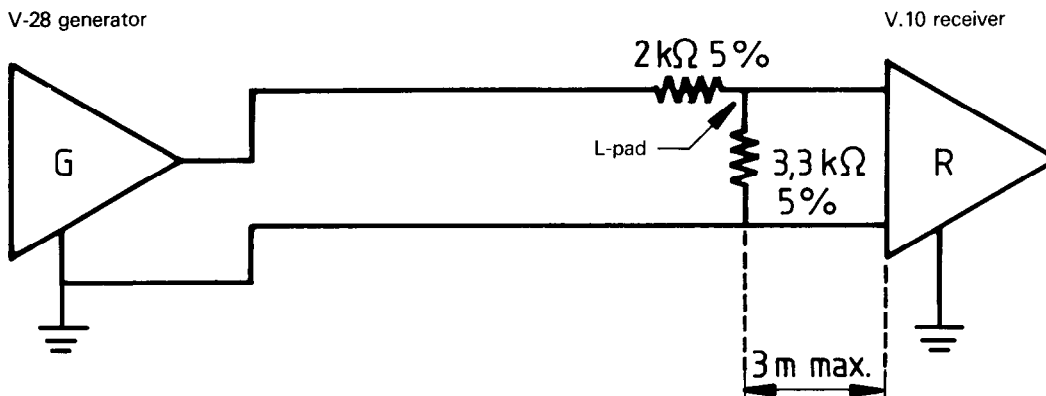
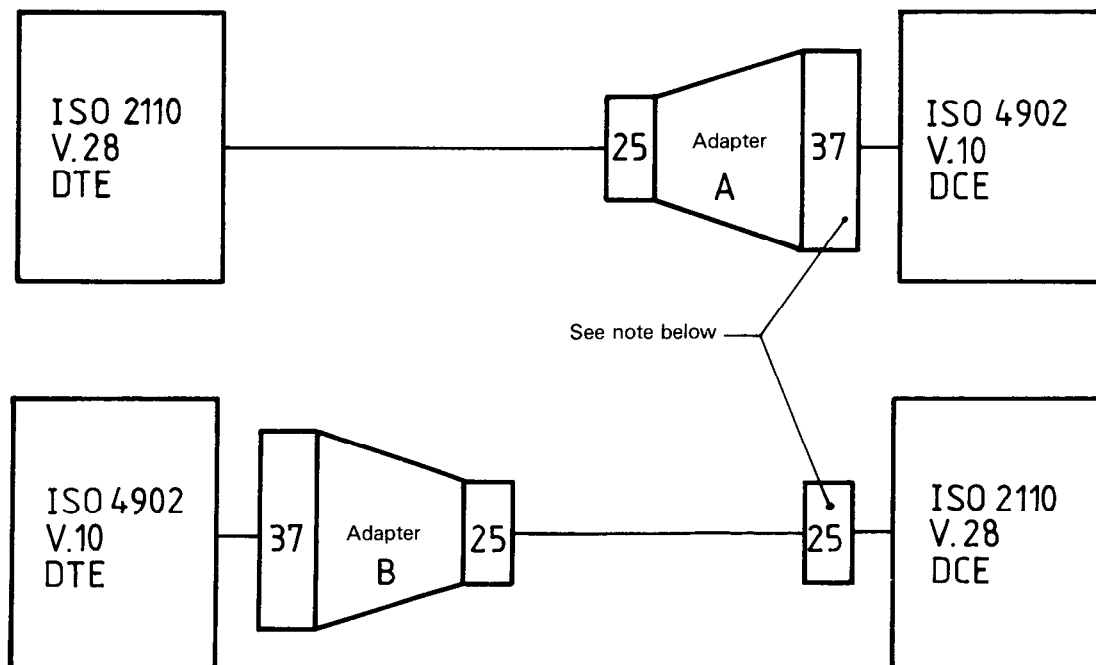

Figure C.3 – L-pad attenuator for protection of V.10 receiver



NOTE – CCITT Recommendation V.24 indicates that the connector will not necessarily be physically attached to the DCE.

Figure C.4 – Typical interconnection configurations with basic 37/25-pole adapters

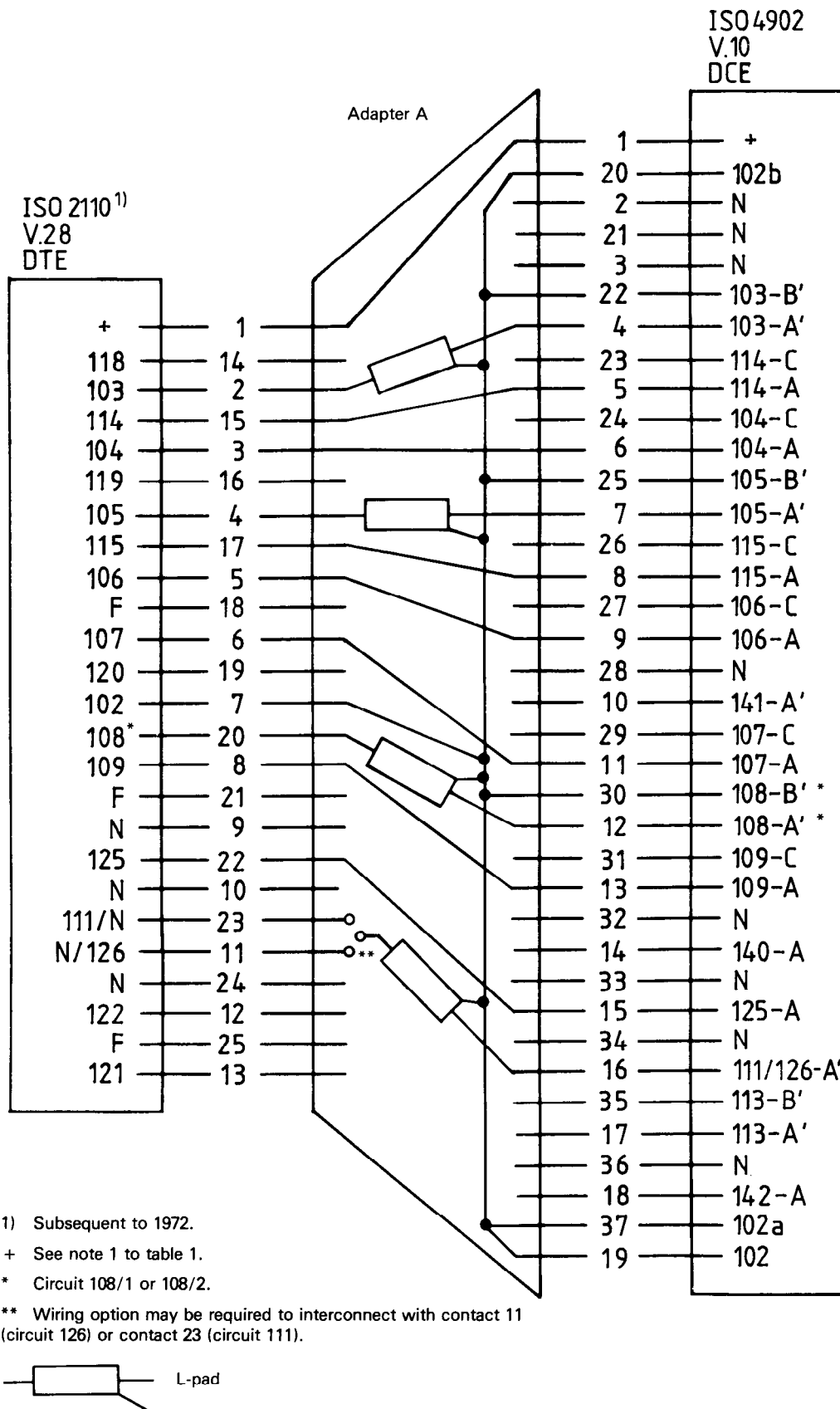

Figure C.5a) – 37/25-pole basic adapter, configuration A

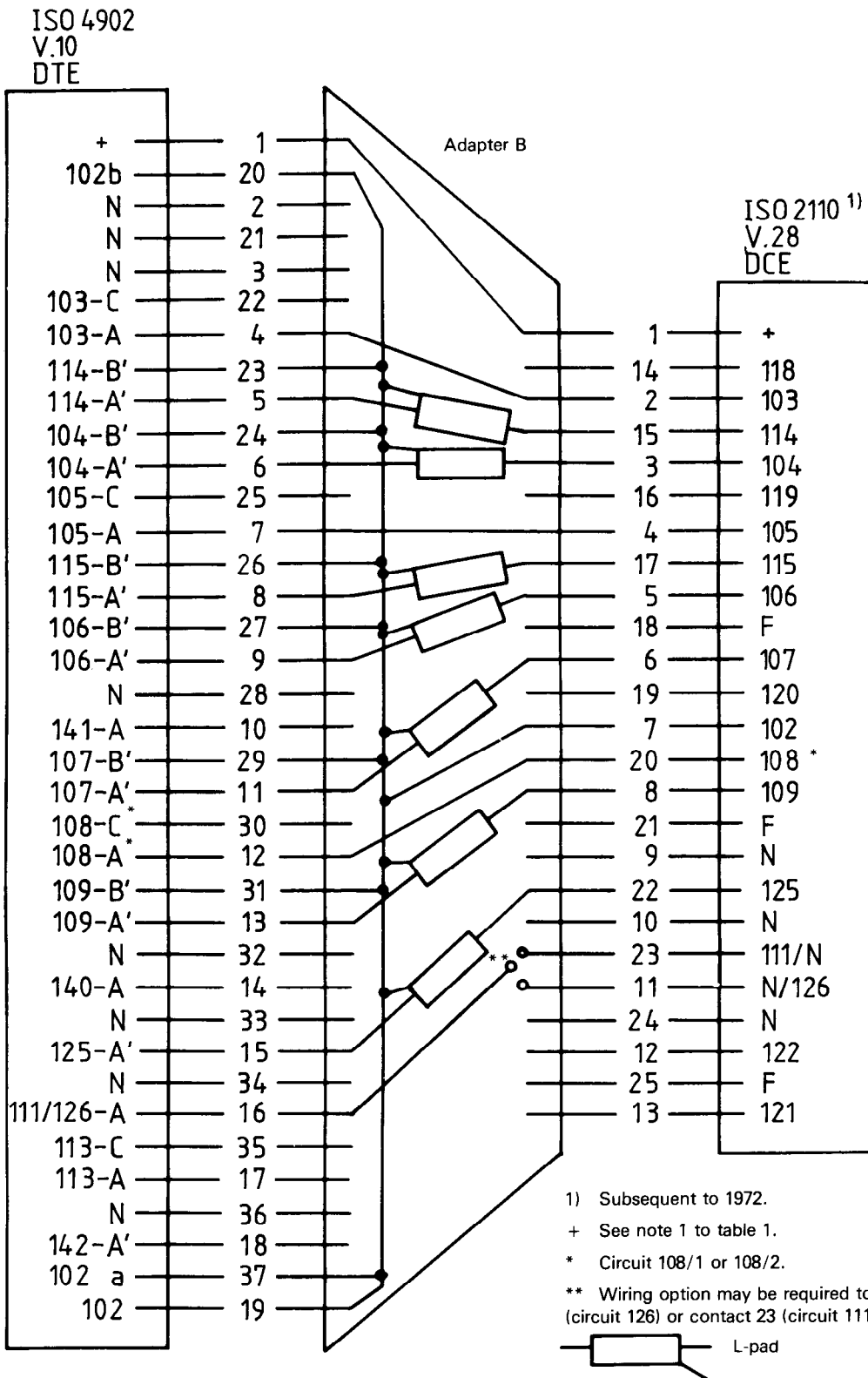

Figure C.5b) – 37/25-pole basic adapter, configuration B

UDC 681.327.8 : 621.316.541

Descriptors : data processing, data transmission, network interconnection, data communication equipment, connecting equipment, electric connectors, connector pins, multi-contact connectors, specifications, dimensions, layout, numbering.

Price based on 18 pages