

INTERNATIONAL STANDARD

ISO
4796-3

First edition
2000-04-01

Laboratory glassware — Bottles — Part 3: Aspirator bottles

*Verrerie de laboratoire — Flacons —
Partie 3: Flacons à tubulure basse*



Reference number
ISO 4796-3:2000(E)

© ISO 2000

PDF disclaimer

This PDF file may contain embedded typefaces. In accordance with Adobe's licensing policy, this file may be printed or viewed but shall not be edited unless the typefaces which are embedded are licensed to and installed on the computer performing the editing. In downloading this file, parties accept therein the responsibility of not infringing Adobe's licensing policy. The ISO Central Secretariat accepts no liability in this area.

Adobe is a trademark of Adobe Systems Incorporated.

Details of the software products used to create this PDF file can be found in the General Info relative to the file; the PDF-creation parameters were optimized for printing. Every care has been taken to ensure that the file is suitable for use by ISO member bodies. In the unlikely event that a problem relating to it is found, please inform the Central Secretariat at the address given below.

© ISO 2000

All rights reserved. Unless otherwise specified, no part of this publication may be reproduced or utilized in any form or by any means, electronic or mechanical, including photocopying and microfilm, without permission in writing from either ISO at the address below or ISO's member body in the country of the requester.

ISO copyright office
Case postale 56 • CH-1211 Geneva 20
Tel. + 41 22 749 01 11
Fax + 41 22 734 10 79
E-mail copyright@iso.ch
Web www.iso.ch

Printed in Switzerland

Foreword

ISO (the International Organization for Standardization) is a worldwide federation of national standards bodies (ISO member bodies). The work of preparing International Standards is normally carried out through ISO technical committees. Each member body interested in a subject for which a technical committee has been established has the right to be represented on that committee. International organizations, governmental and non-governmental, in liaison with ISO, also take part in the work. ISO collaborates closely with the International Electrotechnical Commission (IEC) on all matters of electrotechnical standardization.

International Standards are drafted in accordance with the rules given in the ISO/IEC Directives, Part 3.

Draft International Standards adopted by the technical committees are circulated to the member bodies for voting. Publication as an International Standard requires approval by at least 75 % of the member bodies casting a vote.

Attention is drawn to the possibility that some of the elements of this part of ISO 4796 may be the subject of patent rights. ISO shall not be held responsible for identifying any or all such patent rights.

International Standard ISO 4796-3 was prepared by Technical Committee ISO/TC 48, *Laboratory glassware and related apparatus*, Subcommittee SC 2, *General laboratory glassware (other than measuring apparatus)*.

ISO 4796 consists of the following parts, under the general title *Laboratory glassware — Bottles*:

- *Part 1: Screw-neck bottles*
- *Part 2: Conical neck bottles*
- *Part 3: Aspirator bottles*

Laboratory glassware — Bottles —

Part 3: Aspirator bottles

1 Scope

This part of ISO 4796 specifies a series of aspirator bottles with a screw neck or with a conical neck suitable for the delivery of liquid chemicals and reagents in general laboratory use.

2 Normative references

The following normative documents contain provisions which, through reference in this text, constitute provisions of this part of ISO 4796. For dated references, subsequent amendments to, or revisions of, any of these publications do not apply. However, parties to agreements based on this part of ISO 4796 are encouraged to investigate the possibility of applying the most recent editions of the normative documents indicated below. For undated references, the latest edition of the normative document referred to applies. Members of ISO and IEC maintain registers of currently valid International Standards.

ISO 383:1976, *Laboratory glassware — Interchangeable conical ground joints.*

ISO 4796-1:2000, *Laboratory glassware — Bottles — Part 1: Screw-neck bottles.*

ISO 4796-2:2000, *Laboratory glassware — Bottles — Part 2: Conical neck bottles.*

3 Types and capacities

3.1 There are three types of aspirator bottles specified in this part of ISO 4796:

- type ASN: aspirator bottles with a screw neck;
- type ACS: aspirator bottles with a conical neck socket;
- type ACJ: aspirator bottles with an interchangeable conical ground joint.

3.2 The nominal capacities of aspirator bottles shall be chosen from the following series:

0,5 l — 1 l — 2 l — 5 l — 10 l and 20 l

3.3 The nominal capacity of an aspirator bottle indicates the quantity of liquid which a bottle of average wall thickness shall contain when the bottle is filled to the turn of the shoulder.

3.4 The design of the bottle shall be such that the total capacity to the base of the neck shall be approximately 15 % greater than that to the shoulder.

4 Dimensions

The dimensions and tolerances of aspirator bottles are given in Figure 1 and in Tables 1 and 2 below.

Table 1 — Dimensions of aspirator bottles with a screw neck

Nominal capacity	Total height	Height to shoulder	Outside diameter	Wall thickness
<i>l</i>	h_1 mm approx.	h_2 mm approx.	d mm approx.	s mm min.
1	225	153	100	2,0
2	260	170	136	2,0
5	330	208	181	2,0
10	410	265	227	2,7
20	505	330	288	3,0

Table 2 — Dimensions of aspirator bottles with a conical neck

Nominal capacity	Total height	Outside diameter	Wall thickness	Neck socket ^a	Ground joint at outlet
<i>l</i>	h_1 mm approx.	d mm approx.	s mm min.		
0,5	162	86	1,3	24/29	19/26
1	198	107	1,7	29/32	19/26
2	246	133	2,0	29/32	19/26
5	318	181	2,0	45/40	29/32
10	398	227	2,7	60/46	29/32
20	492	288	3,0	60/46	29/32

^a Or ground joint in accordance with ISO 383 (see 5.2.8 for details)

5 Construction

5.1 Material

In accordance with 5.1 of ISO 4796-1:2000.

5.2 Design

5.2.1 The base of the bottle shall be constructed so as to enable the bottle to stand firmly on a flat surface without rocking or spinning.

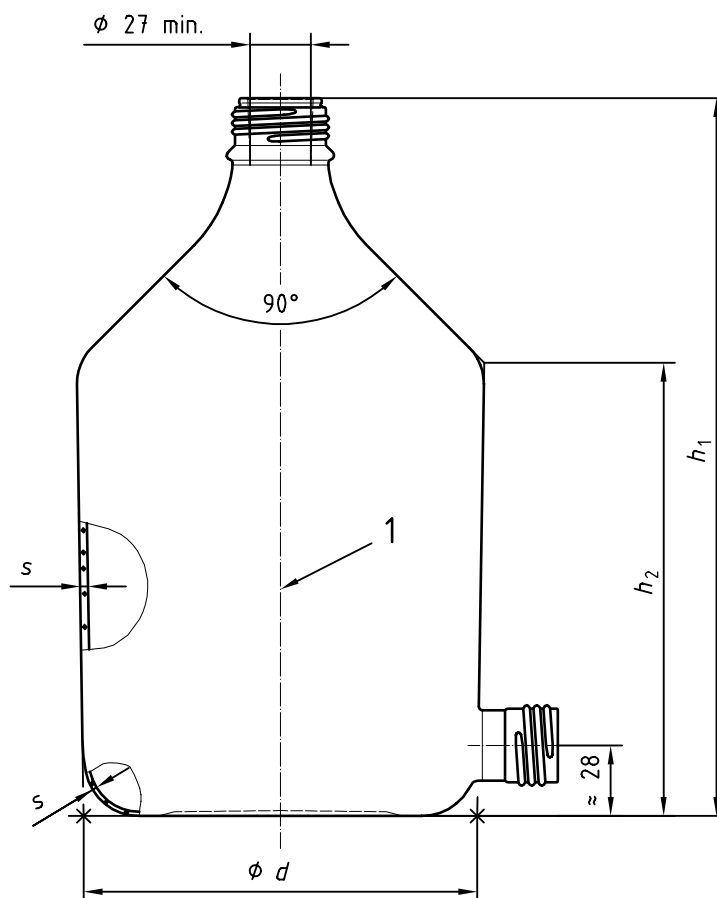
**Key**

1 Taper 1:30

Figure 1 — Example of an aspirator bottle

5.2.2 The base of the bottle shall have a suitable radius in order to provide a smooth transition between the base and the side. The main portion of the side shall be slightly tapered with the smaller diameter at the base of the bottle.

The diameter d and the heights h_1 and h_2 shall be as given in Tables 1 and 2.

5.2.3 The shoulder of the bottle shall have a suitable radius so as to provide a smooth transition between the side and the conical upper proportion of the bottle.

5.2.4 The upper portion of the shoulder shall be of conical shape. The transition radius from the shoulder to the neck shall be as small as possible to be compatible with good manufacturing practice.

5.2.5 The bottle shall be blown so as to evenly distribute the glass in the mould avoiding sudden changes in the wall thickness. The thinnest areas shall not have a thickness less than the minimum values specified in Table 1.

ISO 4796-3:2000(E)

5.2.6 The neck of the bottle shall be stoutly constructed and finished with a strengthening lip designed to facilitate pouring without liquid running down the outside of the bottle. A clip-on anti-drip ring of plastics material fitting into a slightly recessed channel on the outside of the neck is permitted as an alternative for aspirator bottles with a screw neck.

NOTE There are suitable national standards for the dimensions and design of the thread of the screw neck.

5.2.7 The outer glass surface of the bottles may be coated with a suitable plastics material for protection and to limit leakage of a liquid if the bottle is damaged. The coating shall be resistant to steam sterilization at 135 °C.

5.2.8 The internal surface of the conical neck socket shall be smooth, suitable to fit with a rubber stopper, or shall be finished by fine grinding. If the surface is finished, the grinding shall comply with the interchangeable conical ground joints specified in ISO 383 and dimensions specified in Table 2 of this part of ISO 4796. If the socket surface is smooth, the socket dimensions shall be suited for finishing by fine grinding so as to fit an interchangeable conical ground joint specified in Table 1.

5.2.9 The outlet in the side wall of the bottle shall have a distance of approximately 28 mm (see Figure 1) from the bottom. The outlet shall be supplied with an interchangeable ground joint, size 19/26 or 29/32 in accordance with ISO 383, or with an external screw thread, complying with suitable national or International Standards.

5.3 Closure for aspirator bottles with a screw neck

In accordance with 5.3 of ISO 4796-1:2000.

5.4 Stoppers for aspirator bottles with a conical neck

In accordance with 5.3 of ISO 4796-2:2000.

6 Designation

If a designation of bottles is required, this shall be by reference to this part of ISO 4796, i.e. ISO 4796-3, together with the nominal capacity of the bottle and the type specified in 3.1.

EXAMPLE For a bottle with a nominal capacity of 2 l and of type ACS (aspirator bottle with a conical neck socket), the designation would be as follows:

Laboratory bottle ISO 4796-3 - 2 ACS

7 Marking

In accordance with clause 7 of ISO 4796-1:2000.

ICS 71.040.20

Price based on 4 pages

© ISO 2000 – All rights reserved