

INTERNATIONAL STANDARD

ISO
4796-2

First edition
2000-04-01

Laboratory glassware — Bottles — Part 2: Conical neck bottles

*Verrerie de laboratoire — Flacons —
Partie 2: Flacons à col conique*



Reference number
ISO 4796-2:2000(E)

© ISO 2000

PDF disclaimer

This PDF file may contain embedded typefaces. In accordance with Adobe's licensing policy, this file may be printed or viewed but shall not be edited unless the typefaces which are embedded are licensed to and installed on the computer performing the editing. In downloading this file, parties accept therein the responsibility of not infringing Adobe's licensing policy. The ISO Central Secretariat accepts no liability in this area.

Adobe is a trademark of Adobe Systems Incorporated.

Details of the software products used to create this PDF file can be found in the General Info relative to the file; the PDF-creation parameters were optimized for printing. Every care has been taken to ensure that the file is suitable for use by ISO member bodies. In the unlikely event that a problem relating to it is found, please inform the Central Secretariat at the address given below.

© ISO 2000

All rights reserved. Unless otherwise specified, no part of this publication may be reproduced or utilized in any form or by any means, electronic or mechanical, including photocopying and microfilm, without permission in writing from either ISO at the address below or ISO's member body in the country of the requester.

ISO copyright office
Case postale 56 • CH-1211 Geneva 20
Tel. + 41 22 749 01 11
Fax + 41 22 734 10 79
E-mail copyright@iso.ch
Web www.iso.ch

Printed in Switzerland

Foreword

ISO (the International Organization for Standardization) is a worldwide federation of national standards bodies (ISO member bodies). The work of preparing International Standards is normally carried out through ISO technical committees. Each member body interested in a subject for which a technical committee has been established has the right to be represented on that committee. International organizations, governmental and non-governmental, in liaison with ISO, also take part in the work. ISO collaborates closely with the International Electrotechnical Commission (IEC) on all matters of electrotechnical standardization.

International Standards are drafted in accordance with the rules given in the ISO/IEC Directives, Part 3.

Draft International Standards adopted by the technical committees are circulated to the member bodies for voting. Publication as an International Standard requires approval by at least 75 % of the member bodies casting a vote.

Attention is drawn to the possibility that some of the elements of this part of ISO 4796 may be the subject of patent rights. ISO shall not be held responsible for identifying any or all such patent rights.

International Standard ISO 4796-2 was prepared by Technical Committee ISO/TC 48, *Laboratory glassware and related apparatus*, Subcommittee SC 2, *General laboratory glassware (other than measuring apparatus)*.

Parts 1 and 2 of ISO 4796 cancel and replace ISO 4796:1977 by incorporating the following changes:

- a) bottles with capacities of 25 ml, 30 ml, 2 500 ml and 20 000 ml have been added;
- b) the material has been more precisely defined;
- c) the International Standard has been divided into three parts.

ISO 4796 consists of the following parts, under the general title *Laboratory glassware — Bottles*:

- *Part 1: Screw-neck bottles*
- *Part 2: Conical neck bottles*
- *Part 3: Aspirator bottles*

Laboratory glassware — Bottles —

Part 2: Conical neck bottles

1 Scope

This part of ISO 4796 specifies a series of bottles with a conical, wide or narrow neck with or without ground joints, suitable for the storage of liquid and solid chemicals and reagents in general laboratory use.

2 Normative references

The following normative documents contain provisions which, through reference in this text, constitute provisions of this part of ISO 4796. For dated references, subsequent amendments to, or revisions of, any of these publications do not apply. However, parties to agreements based on this part of ISO 4796 are encouraged to investigate the possibility of applying the most recent editions of the normative documents indicated below. For undated references, the latest edition of the normative document referred to applies. Members of ISO and IEC maintain registers of currently valid International Standards.

ISO 383:1976, *Laboratory glassware — Interchangeable conical ground joints.*

ISO 719:1985, *Glass — Hydrolytic resistance of glass grains at 98 °C — Method of test and classification.*

ISO 3585:1998, *Borosilicate glass 3.3 — Properties.*

ISO 4796-1:2000, *Laboratory glassware — Bottles — Part 1: Screw-neck bottles.*

3 Types and capacities

3.1 There are four types of conical neck bottles specified in this part of ISO 4796:

- type WS: wide-necked bottles with a conical socket;
- type WJ: wide-necked bottles with an interchangeable conical ground joint;
- type NS: narrow-necked bottles with a conical socket;
- type NJ: narrow-necked bottles with an interchangeable conical ground joint.

3.2 The nominal capacities of conical neck bottles shall be chosen from the following series:

- wide-necked bottles: 50 ml — 100 ml — 250 ml — 500 ml — 1 000 ml and 2 000 ml;
- narrow-necked bottles: 25 ml — 30 ml — 50 ml — 100 ml — 250 ml — 500 ml — 1 000 ml — 2 000 ml — 2 500 ml — 5 000 ml — 10 000 ml and 20 000 ml.

3.3 The nominal capacity of a bottle indicates the quantity of liquid which a bottle of average wall thickness shall contain when the bottle is filled to the turn of the shoulder.

3.4 The design of the bottle shall be such that the total capacity to the base of the neck shall be approximately 15 % greater than that to the shoulder.

4 Dimensions

The dimensions and tolerances of conical neck bottles are given in Figures 1 and 2 and in Table 1.

Table 1 — Dimensions

Nominal capacity	Total height <i>h</i>	Outside diameter <i>d</i>	Wall thickness <i>s</i>	Recommended socket/ground joint ^a	
				wide neck	narrow neck
ml	mm approx.	mm approx.	mm min.		
25	64	36	1,0	—	12/21
30	78	36	1,0	—	16/16
50	78	42	1,0	24/20	14/15
100	95	52	1,2	29/22	14/15 or 14/23
250	128	70	1,3	34/35	19/22 or 19/26
500	162	86	1,3	45/40	24/29
1 000	198	107	1,7	60/46	29/32
2 000	246	133	2,0	60/46	29/32
2 500	295	140	2,0	—	24/20
5 000	318	181	2,0	—	45/40
10 000	398	227	2,7	—	60/46
20 000	492	288	3,0	—	60/46

^a In accordance with ISO 383 (see 5.2.8 for details)

5 Construction

5.1 Material

5.1.1 Bottles with conical necks shall be constructed of clear, colourless or amber borosilicate glass 3.3 in accordance with ISO 3585 or from other glass types, complying with the requirements of class HGB 3 or better specified in ISO 719.

5.1.2 Internal stress and visible defects in the glass (such as bubbles near the surface) shall be reduced to a level sufficient to minimize the possibility of fracture due to thermal or mechanical shock.

5.2 Design

5.2.1 The base of the bottle shall be constructed so as to enable the bottle to stand firmly on a flat surface without rocking or spinning.

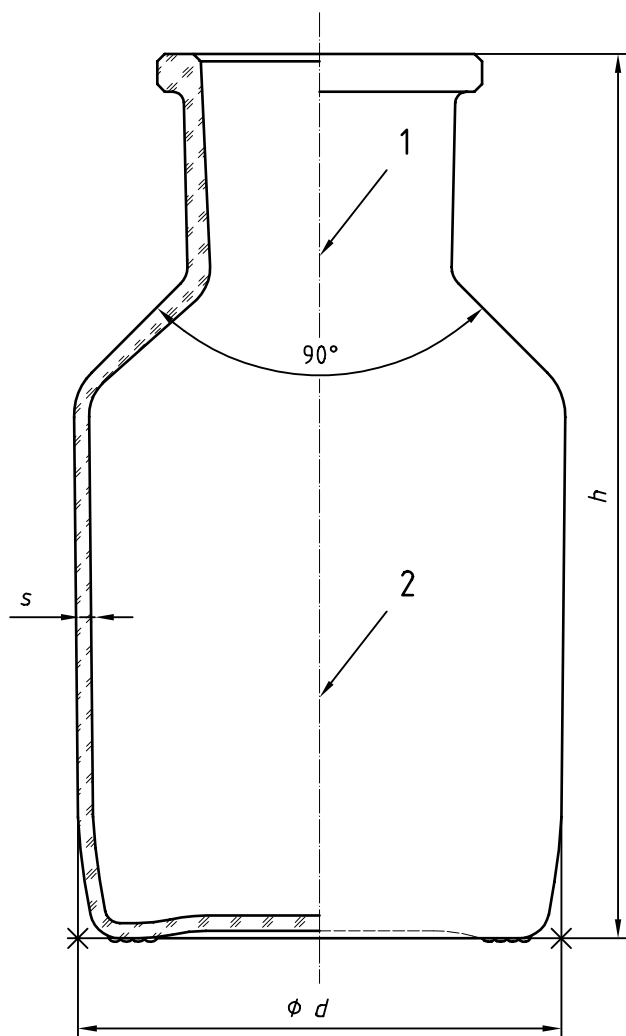
**Key**

- 1 Taper 1:10
2 Taper 1:30

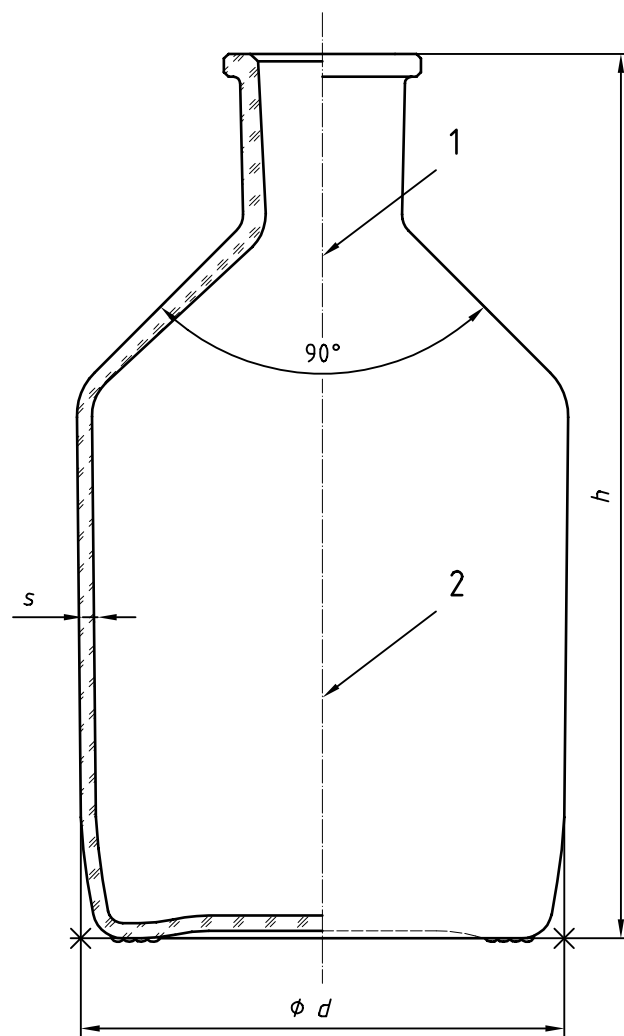
Figure 1 — Wide-necked bottle**Key**

- 1 Taper 1:10
2 Taper 1:30

Figure 2 — Narrow-necked bottle

5.2.2 The base of the bottle shall have a suitable radius so as to provide a smooth transition between the base and the side. The main portion of the side shall be slightly tapered with the smaller diameter at the base of the bottle.

The diameters d and the heights h shall be as given in Table 1.

5.2.3 The shoulder of the bottle shall have a suitable radius in order to provide a smooth transition between the side and the conical upper portion of the bottle.

5.2.4 The upper portion of the shoulder shall be of conical shape. The transition radius from the upper portion of the shoulder to the neck shall be as small as possible to be compatible with good manufacturing practice.

5.2.5 The bottle shall be blown so as to evenly distribute the glass in the mould avoiding sudden changes in the wall thickness. The thinnest areas shall not have a thickness less than the minimum values specified in Table 1.

5.2.6 The neck of the bottle shall be stoutly constructed and finished with a strengthening lip designed to facilitate pouring without liquid running down the outside of the bottle.

5.2.7 The outer glass surface of the bottles may be coated with a suitable plastics material as a protection and to limit leakage of liquid if the bottle is damaged. The coating shall be resistant to steam sterilization at 135 °C.

5.2.8 The internal surface of the conical neck socket shall be smooth, suitable to fit with a rubber stopper, or shall be finished by fine grinding. If the surface is finished, the grinding shall comply with the interchangeable conical ground joints specified in ISO 383 and with the dimensions specified in Table 1 of this part of ISO 4796. If the socket surface is smooth, the socket dimensions shall be suited for finishing by fine grinding so as to fit an interchangeable conical ground joint specified in Table 1.

5.3 Stoppers

5.3.1 Bottles shall be provided with stoppers of glass, rubber or of a suitable inert plastics material.

5.3.2 Glass stoppers shall be made of glass of a similar coefficient of thermal expansion to that of the bottle. The glass stoppers shall be ground to a joint complying with the requirements of ISO 383 and they shall comply with the sizes given in Table 1.

5.3.3 Rubber stoppers shall be dimensioned to fit with the conical smooth socket of the bottle neck, given in Table 1.

5.3.4 Plastics stoppers shall be made from a suitable inert material, for example polypropylene or polyethylene, and shall be moulded to fit with the interchangeable conical ground joint of the bottle neck.

5.3.5 Glass or plastic stoppers should have a flat top with a grip, larger than the diameter of the lip of the neck with which they are intended to be used. The grip shall facilitate removal of the stopper from the neck of the bottle, for example by being of a hexagonal or similar shape.

6 Designation

If a designation of bottles is required, this shall be by reference to this part of ISO 4796, i.e. ISO 4796-2, together with the nominal capacity and the type specified in 3.1.

EXAMPLE For a bottle with a nominal capacity of 100 ml and of type WS (wide-necked bottle with a conical socket), the designation would be as follows:

Laboratory bottle ISO 4796-2 - 100 WS

7 Marking

In accordance with ISO 4796-1:2000.

