

---

---

**Laboratory glassware — Bottles —**

**Part 1:  
Screw-neck bottles**

*Verrerie de laboratoire — Flacons —  
Partie 1: Flacons à col à vis*





**COPYRIGHT PROTECTED DOCUMENT**

© ISO 2016, Published in Switzerland

All rights reserved. Unless otherwise specified, no part of this publication may be reproduced or utilized otherwise in any form or by any means, electronic or mechanical, including photocopying, or posting on the internet or an intranet, without prior written permission. Permission can be requested from either ISO at the address below or ISO's member body in the country of the requester.

ISO copyright office  
Ch. de Blandonnet 8 • CP 401  
CH-1214 Vernier, Geneva, Switzerland  
Tel. +41 22 749 01 11  
Fax +41 22 749 09 47  
copyright@iso.org  
www.iso.org

# Contents

Page

Foreword .....	iv
<b>1 Scope .....</b>	<b>1</b>
<b>2 Normative references .....</b>	<b>1</b>
<b>3 Capacities .....</b>	<b>1</b>
<b>4 Dimensions .....</b>	<b>1</b>
<b>5 Construction .....</b>	<b>3</b>
5.1 Material .....	3
5.2 Design .....	3
5.3 Closures .....	4
<b>6 Designation .....</b>	<b>4</b>
<b>7 Marking .....</b>	<b>4</b>

## Foreword

ISO (the International Organization for Standardization) is a worldwide federation of national standards bodies (ISO member bodies). The work of preparing International Standards is normally carried out through ISO technical committees. Each member body interested in a subject for which a technical committee has been established has the right to be represented on that committee. International organizations, governmental and non-governmental, in liaison with ISO, also take part in the work. ISO collaborates closely with the International Electrotechnical Commission (IEC) on all matters of electrotechnical standardization.

The procedures used to develop this document and those intended for its further maintenance are described in the ISO/IEC Directives, Part 1. In particular the different approval criteria needed for the different types of ISO documents should be noted. This document was drafted in accordance with the editorial rules of the ISO/IEC Directives, Part 2 (see [www.iso.org/directives](http://www.iso.org/directives)).

Attention is drawn to the possibility that some of the elements of this document may be the subject of patent rights. ISO shall not be held responsible for identifying any or all such patent rights. Details of any patent rights identified during the development of the document will be in the Introduction and/or on the ISO list of patent declarations received (see [www.iso.org/patents](http://www.iso.org/patents)).

Any trade name used in this document is information given for the convenience of users and does not constitute an endorsement.

For an explanation on the meaning of ISO specific terms and expressions related to conformity assessment, as well as information about ISO's adherence to the WTO principles in the Technical Barriers to Trade (TBT) see the following URL: [Foreword - Supplementary information](#).

The committee responsible for this document is ISO/TC 48, *Laboratory equipment*.

This second edition cancels and replaces the first edition (ISO 4796-1:2000), which has been technically revised to include screw-neck bottles with nominal capacities of 150 ml, 750 ml, and 3 500 ml.

ISO 4796 consists of the following parts, under the general title *Laboratory glassware — Bottles*:

- *Part 1: Screw-neck bottles*
- *Part 2: Conical neck bottles*
- *Part 3: Aspirator bottles*

# Laboratory glassware — Bottles —

## Part 1: Screw-neck bottles

### 1 Scope

This part of ISO 4796 specifies a series of screw-neck bottles suitable for the storage of fluid liquid and solid chemicals and reagents in general laboratory use. These bottles with nominal volumes ranging from 25 ml to 20 000 ml are also suitable for the preparation and storage of microbiological growth media.

### 2 Normative references

The following documents, in whole or in part, are normatively referenced in this document and are indispensable for its application. For dated references, only the edition cited applies. For undated references, the latest edition of the referenced document (including any amendments) applies.

ISO 3585, *Borosilicate glass 3.3 — Properties*

### 3 Capacities

**3.1** The nominal capacities of screw-neck bottles shall be chosen from the following series:

- 25 ml — 50 ml — 100 ml — 150 ml — 250 ml — 500 ml and 750 ml;
- 1 l — 2 l — 3,5 l — 5 l — 10 l — 15 l and 20 l.

**3.2** The nominal capacity of a bottle indicates the quantity of liquid which a bottle of average wall thickness shall contain when the bottle is filled to the turn of the shoulder.

**3.3** The design of the bottle shall be such that the total capacity to the base of the neck shall be approximately 15 % greater than that to the shoulder.

### 4 Dimensions

The dimensions and tolerances of screw-neck bottles are given in [Figure 1](#), [Figure 2](#), and [Table 1](#).

**Table 1 — Dimensions**

Nominal capacity	Total height $h_1$	Height to shoulder $h_2$	Outside diameter $d_1$	Wall thickness $s$	Internal neck diameter $d_2$
ml	mm approx.	mm approx.	mm approx.	mm min.	mm min.
25	70	41	36	1,0	12,5
50	87	50	46	1,0	15
100	100	60	56	1,5	27
150	110	70	62	1,5	27

**Table 1** (continued)

Nominal capacity ml	Total height $h_1$ mm approx.	Height to shoulder $h_2$ mm approx.	Outside diameter $d_1$ mm approx.	Wall thickness $s$ mm min.	Internal neck diameter $d_2$ mm min.
250	138	90	70	1,5	27
500	176	110	86	1,5	27
750	204	133	95	1,7	27
1 000	225	153	101	1,7	27
2 000	260	170	136	2,0	27
3 500	295	184	161	2,0	27
5 000	330	208	181	2,0	27
10 000	410	265	227	2,7	27
15 000	445	285	268	2,7	27
20 000	505	330	288	3,0	27

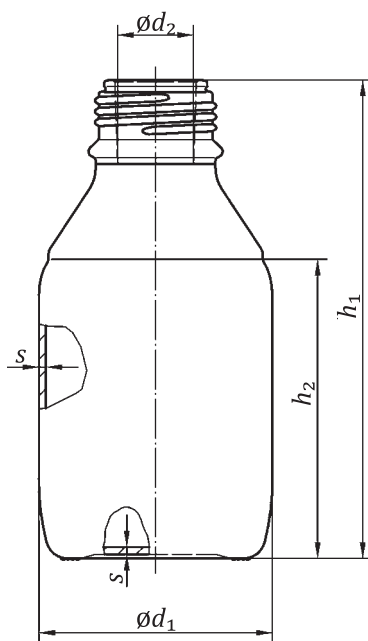

**Figure 1** — Bottles with nominal capacities of 25 ml to 2 000 ml

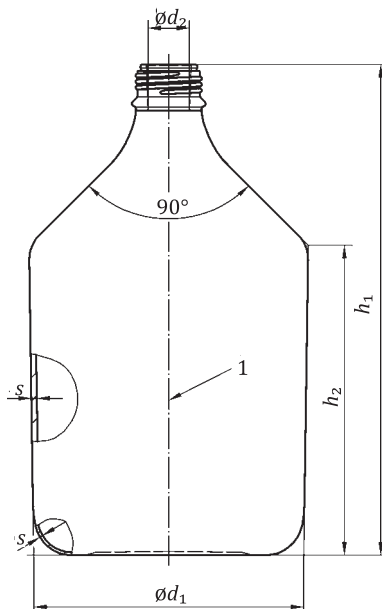

### Key

1 taper 1:30

Figure 2 — Bottles with nominal capacities of 3,5 l to 20 l

## 5 Construction

### 5.1 Material

**5.1.1** Bottles shall be constructed of clear, colourless or amber borosilicate glass 3.3 in accordance with ISO 3585.

**5.1.2** Internal stress and visible defects in the glass (such as bubbles near the surface) shall be reduced to a level sufficient to minimize the possibility of fracture due to thermal or mechanical shock.

### 5.2 Design

**5.2.1** The base of the bottle shall be constructed so as to enable the bottle to stand firmly on a flat surface without rocking or spinning.

**5.2.2** The base of the bottle shall have a suitable radius so as to provide a smooth transition between the base and the side. The main portion of the side shall be

- cylindrical for bottles with nominal capacities of 25 ml to 2 000 ml, and
- slightly tapered for bottles with nominal capacities 3,5 l to 20 l with the smaller diameter at the base of the bottle.

The diameters  $d_1$  shall be as given in [Table 1](#).

**5.2.3** The shoulder of the bottle shall have a suitable radius in order to provide a smooth transition between the side and the conical upper proportion of the bottle.

**5.2.4** The upper portion of the shoulder shall be of conical shape. The transition radius from the shoulder to the neck shall be as small as possible to be compatible with manufacturing practice.

**5.2.5** The bottle shall be blown so as to evenly distribute the glass in the mould avoiding sudden changes in the wall thickness. The thinnest areas shall not have a thickness less than the minimum value specified in [Table 1](#).

**5.2.6** The neck of the bottle shall be stoutly constructed and finished with a strengthening lip designed to facilitate pouring without liquid running down the outside of the bottle. A clip-on anti-trip ring of plastics material fitting into a slightly recessed channel on the outside of the neck is a permitted alternative form of construction.

NOTE There are suitable national standards for the dimensions and design of the thread of the screw neck.

**5.2.7** The outer glass surface of the bottles may be coated with a suitable plastics material as a protection and to limit leakage of liquid if the bottle is damaged. The coating shall be resistant to steam sterilization at 135 °C.

### 5.3 Closures

Bottles shall be provided with closures of a suitable inert plastics material, e.g. polypropylene. Closures shall form a liquid-tight seal with the threaded bottle neck.

## 6 Designation

If a designation of bottles is required, this shall be by reference to this part of ISO 4796, i.e. ISO 4796-1, together with the nominal capacity of the bottle.

EXAMPLE For a bottle with a nominal capacity of 500 ml, the designation would be as follows:

Laboratory bottle ISO 4796-1 — 500

## 7 Marking

**7.1** Bottles complying with this part of ISO 4796 shall be marked with the following:

- a) nominal capacity;
- b) maker's and/or vendor's name and/or trade mark;
- c) number of this International Standard, i.e. ISO 4796-1, or appropriate reference to the correspondending national standard.

In addition, each bottle can bear an area with a surface suitable for marking with a pencil.

Marks a) to c) may be moulded into the recessed base of the bottle, if the method of manufacture permits; otherwise, they may be indelibly marked, in any convenient position, by etching, sandblasting or with vitreous enamel.

**7.2** The closures of the bottles shall be marked with the maximum permitted temperature for use or for sterilization, e.g. "max. 100 °C".

NOTE Closures not marked with a temperature can only be used at ambient temperature.

During sterilization, the closure may not be screwed more than one turn to enable pressure release. Otherwise, pressure increase in the bottle can result in fracture.





