

Second edition
2010-04-15

Corrected version
2010-06-15

**Laboratory glassware — Volumetric
instruments — Methods for testing of
capacity and for use**

*Verrerie de laboratoire — Instruments volumétriques — Méthodes de
vérification de la capacité et d'utilisation*



Reference number
ISO 4787:2010(E)

© ISO 2010

PDF disclaimer

This PDF file may contain embedded typefaces. In accordance with Adobe's licensing policy, this file may be printed or viewed but shall not be edited unless the typefaces which are embedded are licensed to and installed on the computer performing the editing. In downloading this file, parties accept therein the responsibility of not infringing Adobe's licensing policy. The ISO Central Secretariat accepts no liability in this area.

Adobe is a trademark of Adobe Systems Incorporated.

Details of the software products used to create this PDF file can be found in the General Info relative to the file; the PDF-creation parameters were optimized for printing. Every care has been taken to ensure that the file is suitable for use by ISO member bodies. In the unlikely event that a problem relating to it is found, please inform the Central Secretariat at the address given below.



COPYRIGHT PROTECTED DOCUMENT

© ISO 2010

All rights reserved. Unless otherwise specified, no part of this publication may be reproduced or utilized in any form or by any means, electronic or mechanical, including photocopying and microfilm, without permission in writing from either ISO at the address below or its member body in the country of the requester.

ISO copyright office
Case postale 56 • CH-1211 Geneva 20
Tel. + 41 22 749 01 11
Fax + 41 22 749 09 47
-mail copyright@iso.org
Web www.iso.org

Published in Switzerland

Contents

Page

| | |
|---|-----------|
| Foreword | iv |
| 1 Scope | 1 |
| 2 Normative references | 1 |
| 3 Terms and definitions | 2 |
| 4 Summary of method | 2 |
| 5 Volume and reference temperature | 2 |
| 5.1 Unit of volume | 2 |
| 5.2 Reference temperature | 2 |
| 6 Apparatus and calibration liquid | 2 |
| 7 Factors affecting the accuracy of volumetric instruments | 3 |
| 7.1 General | 3 |
| 7.2 Temperature | 3 |
| 7.3 Cleanliness of glass surface | 3 |
| 7.4 Quality of used volumetric instruments | 4 |
| 7.5 Delivery time and waiting time | 4 |
| 8 Setting the meniscus | 4 |
| 8.1 General | 4 |
| 8.2 Meniscus of transparent liquids | 4 |
| 8.3 Meniscus of opaque liquids | 5 |
| 9 Calibration procedure | 5 |
| 9.1 General | 5 |
| 9.2 Test room | 5 |
| 9.3 Filling and delivery | 6 |
| 9.4 Weighing | 7 |
| 9.5 Evaluation | 7 |
| 10 Use | 7 |
| 10.1 General | 7 |
| 10.2 Volumetric flasks (see ISO 1042) | 8 |
| 10.3 Measuring cylinders (see ISO 4788) | 8 |
| 10.4 Burettes (see ISO 385) | 8 |
| 10.5 Pipettes | 9 |
| Annex A (informative) Cleaning of volumetric glassware | 10 |
| Annex B (normative) Calculation of volume | 11 |
| Bibliography | 21 |

Foreword

(the International Organization for Standardization) is a worldwide federation of national standards bodies (ISO member bodies). The work of preparing International Standards is normally carried out through ISO technical committees. Each member body interested in a subject for which a technical committee has been established has the right to be represented on that committee. International organizations, governmental and non-governmental, in liaison with ISO, also take part in the work. ISO collaborates closely with the International Electrotechnical Commission (IEC) on all matters of electrotechnical standardization.

International Standards are drafted in accordance with the rules given in the ISO/IEC Directives, Part 2.

The main task of technical committees is to prepare International Standards. Draft International Standards adopted by the technical committees are circulated to the member bodies for voting. Publication as an International Standard requires approval by at least 75 % of the member bodies casting a vote.

Attention is drawn to the possibility that some of the elements of this document may be the subject of patent rights. ISO shall not be held responsible for identifying any or all such patent rights.

4787 was prepared by Technical Committee ISO/TC 48, *Laboratory equipment*, Subcommittee SC 6, *Laboratory and volumetric ware*.

This second edition cancels and replaces the first edition (ISO 4787:1984), which has been technically revised to incorporate the following changes:

- the potassium dichromate cleaning method in Annex A has been deleted;
- new tables for calculation of test results have been added to Annex B;
- the description of the test (calibration) methods has been modified to be more precise;
- test methods have been separated from recommendations for use.

This corrected version of ISO 4787:2010 incorporates the following corrections:

Figure 1 on page 5 has been corrected to show the correct setting of the meniscus as described in the text;

Figure 2 on page 5 has been improved to better illustrate what the user of the instrument really sees when setting the meniscus.

Laboratory glassware — Volumetric instruments — Methods for testing of capacity and for use

1 Scope

This International Standard provides methods for the testing, calibration and use of volumetric instruments made from glass in order to obtain the best accuracy in use.

NOTE Testing is the process by which the conformity of the individual volumetric instrument with the appropriate standard is determined, culminating in the determination of its error of measurement at one or more points.

The International Standards for the individual volumetric instruments include clauses on the definition of capacity; these clauses describe the method of manipulation in sufficient detail to define the capacity without ambiguity. This International Standard contains supplementary information.

The procedures are applicable to volumetric instruments with nominal capacities in the range of 0,1 ml to 10 000 ml. These include: single-volume pipettes (see ISO 648) without subdivisions; graduated measuring pipettes and dilution pipettes, with partial or complete subdivisions (see ISO 835); burettes (see ISO 385); volumetric flasks (see ISO 1042); and graduated measuring cylinders (see ISO 4788). The procedures are not recommended for testing of volumetric instruments with capacities below 0,1 ml such as micro-glassware.

This International Standard does not deal specifically with pycnometers as specified in ISO 3507. However, the procedures specified below for the determination of volume of glassware can, for the most part, also be followed for the calibration of pycnometers.

2 Normative references

The following referenced documents are indispensable for the application of this document. For dated references, only the edition cited applies. For undated references, the latest edition of the referenced document (including any amendments) applies.

ISO 385, *Laboratory glassware — Burettes*

ISO 648, *Laboratory glassware — Single-volume pipettes*

ISO 835, *Laboratory glassware — Graduated pipettes*

ISO 1042, *Laboratory glassware — One-mark volumetric flasks*

ISO 3696, *Water for analytical laboratory use — Specification and test methods*

ISO 4788, *Laboratory glassware — Graduated measuring cylinders*

ISO/IEC Guide 99, *International vocabulary of metrology — Basic and general concepts and associated terms (VIM)*

3 Terms and definitions

For the purposes of this document, the terms and definitions given in ISO/IEC Guide 99 apply.

Summary of method

The general procedure is based upon a determination of volume of water, either contained in or delivered by the volumetric instrument. This volume of water is based upon knowledge of its mass under consideration of buoyancy and its tabulated density (gravimetric method).

Volume and reference temperature

Unit of volume

The unit of volume shall be the millilitre (ml), which is equivalent to one cubic centimetre (cm³).

Reference temperature

The standard reference temperature, i.e. the temperature at which the volumetric instrument is intended to contain or deliver its volume (capacity), shall be 20 °C.

When the volumetric instrument is required for use in a country which has adopted a standard reference temperature of 27 °C (the alternative recommended in ISO 384 for tropical use), this figure shall be substituted for 20 °C.

Apparatus and calibration liquid

Balance, with a resolution and standard deviation appropriate to the selected volume of the apparatus under test (see Table 1).

The resolution of the display, the standard deviation and the linearity of the balance will be a limiting factor in the accuracy of the measurements. The balance shall be calibrated with adequate accuracy (see 9.4).

Table 1 — Recommended balance

| Selected volume under test ^a | Resolution | Standard deviation (repeatability) | Linearity |
|---|------------|------------------------------------|-----------|
| <i>V</i> | mg | mg | mg |
| 100 µl < <i>V</i> ≤ 10 ml | 0,1 | 0,2 | 0,2 |
| 10 ml < <i>V</i> < 1 000 ml | 1 | 1 | 2 |
| 1 000 ml ≤ <i>V</i> ≤ 2 000 ml | 10 | 10 | 20 |
| <i>V</i> > 2 000 ml | 100 | 100 | 200 |

^a For practical purposes, the nominal volume may be used to choose the balance.

Thermometer, to measure the temperature of the calibration liquid (water) with a measurement error of maximum 0,2 °C for liquid volumes < 1 000 ml and with a measurement error of maximum 0,1 °C for liquid volumes ≥ 1 000 ml.

Hygrometer, to measure the humidity in the test room with a measurement error of maximum 5 % within the humidity range of 35 % to 85 %.

6.4 Barometer, to measure the atmospheric pressure in the test room with a measurement error of maximum 1 kPa.

6.5 Calibration liquid, distilled or deionized water complying with ISO 3696, Grade 3 should be used for testing.

6.6 Receiving vessel, conical flask with ground joint, manufactured from glass, e.g. in accordance with ISO 4797. The nominal volume of the conical flask shall correspond to the volume of liquid to be measured.

7 Factors affecting the accuracy of volumetric instruments

7.1 General

The same sources of error are, naturally, inherent both in calibration and use. In the former, every attempt is made to reduce these errors to a minimum; in the latter, the care needed is dependent upon the degree of accuracy required. When the greatest possible accuracy is desired, the volumetric instrument should be used as closely as possible to the manner in which it has been calibrated.

7.2 Temperature

7.2.1 Temperature of the volumetric instrument

7.2.1.1 The capacity of the volumetric instruments varies with change of temperature. The particular temperature at which a volumetric instrument is intended to contain or deliver its nominal capacity is the "reference temperature" of the instrument (see 5.2).

7.2.1.2 A volumetric instrument which was adjusted at 20 °C, but used at 27 °C, would show an extra error of only 0,007 % if it is made of borosilicate glass having a coefficient of cubical thermal expansion of $9,9 \times 10^{-6} \text{ }^\circ\text{C}^{-1}$ and of 0,02 % if it is made of soda-lime glass having a coefficient of cubical thermal expansion of $27 \times 10^{-6} \text{ }^\circ\text{C}^{-1}$. These errors are smaller than the limits of error for most volumetric instruments. It follows, therefore, that the reference temperature is of minor importance in practical use. However, when performing calibrations, it is important to refer to the reference temperature.

7.2.2 Temperature of calibration liquid

The temperature of the water used for the calibration shall be measured to $\pm 0,1 \text{ }^\circ\text{C}$. Corrections for differences in temperature from the reference temperature shall be applied in accordance with Annex B.

7.3 Cleanliness of glass surface

The volume contained in, or delivered by, a volumetric instrument depends on the cleanliness of the internal glass surface. Lack of cleanliness results in errors through a poorly shaped meniscus involving two defects:

- incomplete wetting of the glass surface, i.e. the liquid surface meets the glass at an arbitrary angle instead of forming a curve such that it meets the glass tangentially;
- a generally increased radius of curvature, due to contamination of the liquid surface reducing the surface tension.

The ascending or descending liquid meniscus shall not change shape (i.e. it shall not crinkle at its edges). To ascertain whether a piece of glass apparatus is satisfactorily clean, it shall be observed during filling and dispensing. Additionally, an experienced operator can recognize the shape of an uncontaminated meniscus, in relation to its diameter.

Lack of cleanliness causes additional errors with volumetric instruments used for delivery due to the film of liquid on the walls being irregularly distributed or incomplete, e.g. forming drops on the glass surface. Furthermore, chemical residues can introduce an error in the analytical result by contamination. Therefore, where volumetric instruments are fitted with ground stoppers, special attention shall be paid to cleaning the ground zone.

NOTE Small residues of acid, for example, could impair the concentration of the alkaline solution with which the volumetric instrument is filled.

A satisfactory method of cleaning is described in Annex A.

Quality of used volumetric instruments

The glass surface shall be free from obvious damage, the graduations and inscriptions shall be clearly readable and especially with instruments adjusted to deliver the jet shall be free from damage and allow an unrestricted outflow of liquid.

Delivery time and waiting time

For volumetric instruments used for delivery of a liquid, the volume delivered is always less than the volume contained, due to the film of liquid left on the inner walls of the volumetric instrument. The volume of this film depends on the time taken to deliver the liquid, and the volume delivered decreases with decreasing delivery time. For example, the delivered volume of a pipette or burette will decrease if the jet is broken (shorter delivery time) or will increase if the jet is not clean and the outflow of liquid is restricted.

In view of the above, delivery times and waiting times have been specified in the International Standards on volumetric instruments; these times shall be observed.

Setting the meniscus

General

Most volumetric instruments employ the principle of setting or reading a meniscus (the interface between air and the liquid) against a graduation line or ring mark. Wherever practicable, the meniscus should descend to the position of setting.

The tubing of the volumetric instrument shall be in a vertical position. The eye of the testing person shall be in the same horizontal plane as the meniscus or the graduation line (ring mark).

Meniscus of transparent liquids

The meniscus shall be set so that the plane of the upper edge of the graduation line is horizontally tangential to the lowest point of the meniscus, the line of sight being in the same plane (see Figure 1).

The lighting should be arranged so that the meniscus appears dark and distinct in outline. For this purpose, it should be viewed against a white background and shaded from undesirable illumination. This can be achieved, for example, by securing a strip of black or blue paper directly below the level of the graduation line or ring mark or by using a short section of thick black rubber tubing cut open at one side and of such size as to clasp the tube firmly. Parallax is avoided when the graduation lines are of sufficient length to be seen at the front and back of the volumetric instrument simultaneously.

On volumetric instruments which have graduation lines on the front only, parallax can be made negligible when making a setting on the top edge of the line by using the black shading strip, taking care that the top edge of this is in a horizontal plane. In this case, the eye shall be placed so that the front and back portions of the top edge appear to be coincident.

On volumetric instruments fitted with a Schellbach ribbon, the meniscus shall be set using the constriction produced by the interaction between the meniscus and the Schellbach ribbon. Setting is done when the tip of the constriction points to the graduation line (see Figure 2).

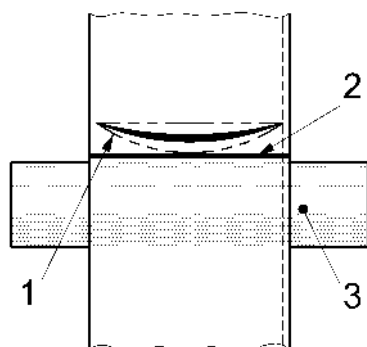

Key

- 1 meniscus of liquid
- 2 graduation line or ring mark
- 3 blue or black (dark) paper or black rubber tubing

Figure 1 — Setting of the meniscus with transparent liquids

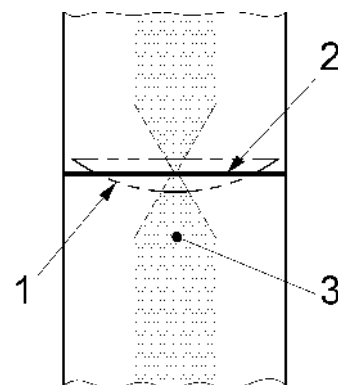

Key

- 1 meniscus
- 2 graduation line
- 3 Schellbach ribbon

Figure 2 — Meniscus with Schellbach ribbon

8.3 Meniscus of opaque liquids

When the volumetric instrument is used with opaque wetting liquids, the horizontal line of sight shall be taken through the upper edge of the meniscus, and, where necessary, an appropriate correction shall be applied.

In the case of a mercury meniscus, however, the highest point of the meniscus shall be set to the lower edge of the graduation line.

9 Calibration procedure

9.1 General

Volumetric instruments other than disposable pipettes shall be thoroughly cleaned shortly before calibration (see 7.3). Volumetric instruments adjusted to contain shall be dried after cleaning.

For volumetric instruments adjusted to deliver, it is important that receiving vessels manufactured from glass are used. Capillary effects influencing the delivery time and the delivered volume depend considerably on the material on which the liquid runs down. In addition, the electrostatic charges of glass are minimal; this is important for the weighing procedure.

9.2 Test room

The test shall be carried out in a draught-free room with stable environment. The test room shall have a relative humidity between 35 % and 85 % and shall provide a temperature locally constant to ± 1 °C and temporally constant to $\pm 0,5$ °C between 15 °C and 30 °C. Prior to the test, the volumetric instrument to be tested and the test water shall have stood in the room for a sufficient time (1 h to 2 h) to reach equilibrium with the room conditions. Test water should be covered to avoid evaporation cooling. Temperatures (room and calibration liquid), atmospheric pressure and humidity should be recorded.

9.3 Filling and delivery

9.3.1 Volumetric flasks and measuring cylinders

Volumetric flasks in accordance with ISO 1042 and measuring cylinders in accordance with ISO 4788 shall be dried after cleaning. They shall be filled by means of a plastic tube with tip to a distance of a few millimetres above the ring mark or the graduation line to be tested, so that the walls of the volumetric instrument considerably above the ring mark are not wetted. The final setting of the meniscus to the ring mark or graduation line shall be made by withdrawing the surplus water by means of a plastic tube drawn out to a jet. The movement of the meniscus when setting shall be downwards. If a little refilling is necessary or if the reading is delayed to the adjustment of the meniscus, careful swaying is necessary to refresh the meniscus shape.

2 Pipettes adjusted to deliver

Pipettes adjusted to deliver according to the specifications in ISO 648 and ISO 835 shall be clamped in a vertical position and filled through the jet to a few millimetres above the graduation line to be tested; any liquid remaining on the outside of the jet shall be removed. The final setting of the meniscus shall then be made by running out the surplus water through the jet. Any drop of liquid adhering to the jet shall be removed, for example by bringing a ground glass surface into contact with the tip of the jet at an angle of about 30°. Draw this ground glass surface downwards through a distance of about 10 mm to remove residual water. Delivery into the tared receiving vessel shall then be made with the flow unrestricted while the tip of the jet is in contact with the inner ground surface of the receiving vessel, finally drawing it over a distance of about 10 mm, with the receiving vessel held inclined at an angle of about 30°.

Other precautions which are necessary to obtain the correct delivered volume vary with different types of instruments and are described in the clause defining capacity in the appropriate International Standards.

Determine the delivery time while the tip of the jet is in contact with the inner surface of the receiving vessel, above the level of any collected liquid, but without movement of one against the other throughout the delivery period. The delivery time thus determined should be within the limits specified for the particular pipette. For further details, see ISO 648 and ISO 835.

A waiting time, if specified, shall be observed before making the final setting of the meniscus for delivery of a given volume. If the setting after delivery is done at a lower graduation line, the liquid flow shall be nearly stopped a few millimetres above the graduation line. After observation of the waiting time, the final setting shall be completed quickly.

3 Pipettes adjusted to contain

10.5.2.

4 Burettes adjusted to deliver

Burettes adjusted to deliver according to ISO 385 shall be clamped in a vertical position and filled through the jet to a few millimetres above the graduation line to be tested. The stopcock and jet shall be freed from air bubbles. Any liquid remaining on the outside of the jet shall be removed. The final setting of the meniscus shall then be made by running out the surplus water through the jet. Any drop of liquid adhering to the jet shall be removed by bringing a ground glass surface into contact with the tip of the jet at an angle of about 30°. Draw this ground glass surface downwards through a distance of about 10 mm.

Delivery into the tared receiving vessel shall then be made with the flow unrestricted until the meniscus has come to a few millimetres above the graduation line to be tested, while the stopcock is fully open and the jet is not in contact with the receiving vessel. After the final setting of the meniscus, any drop of liquid adhering to the jet is removed by bringing an inclined glass surface into contact with the tip of the jet at an angle of about 30°, finally drawing it over a distance of about 10 mm.

Other precautions which are necessary to obtain the correct delivered volume vary with different types of burettes and are described in the appropriate International Standards in the clause defining capacity.

Determine the delivery time by the unrestricted outflow of the liquid from the zero mark to the lowest graduation mark with the stopcock fully open and the jet not being in contact with the surface of the receiving vessel. The delivery time thus determined should be within the limits specified for the particular burette. For further details, see ISO 385.

A waiting time, if specified, shall be observed before making the final setting of the meniscus for delivery of a given volume. If the setting after delivery is done at a lower graduation line, the liquid flow shall be nearly stopped a few millimetres above the graduation line. After observation of the waiting time, the final setting shall be completed quickly.

9.4 Weighing

The volumetric instrument or the receiving vessel (see 6.6) shall be tared and weighed using a balance in accordance with 6.1 and the temperature of the water shall be measured to $\pm 0,1$ °C.

Alternatively, two weighings can be performed, namely I_L , referring to the loaded vessel, and I_E , referring to the empty vessel. Usually, I_E and I_L are observed under the same conditions, hence a precise zero adjustment of the balance is not necessary. Both of the required weighings shall be carried out in as short a time interval as convenient to ensure that they have been made at the same temperature. This temperature and the barometric pressure shall be recorded for use in the subsequent calculations.

The manufacturer's instructions shall be followed in making the requisite measurements. Weighings shall be made with care and made expeditiously to minimize evaporation losses which would constitute a source of error.

9.5 Evaluation

The balance reading after tare or the difference of the results of the first and second weighing is the apparent mass of the water contained in, or delivered by, the volumetric instrument tested.

NOTE The apparent mass, thus obtained, is the mass uncorrected for air buoyancy.

In order to obtain the volume contained in, or delivered by, the volumetric instrument under test at the reference temperature from the apparent mass of water, the following factors shall be taken into account:

- a) the density of water at the temperature of test;
- b) the thermal expansion of the glass between the temperature of test and the reference temperature;
- c) the effect of air buoyancy on the water and on the weights used.

Instructions for calculating the volume of the instrument and tables, in which these factors have been taken into account for a reference temperature of 20 °C, are given in Annex B.

10 Use

10.1 General

Where the greatest attainable accuracy is required, volumetric instruments shall be manipulated in a manner as similar as possible to that employed during calibration as described in Clause 9. For further details, see the relevant clause "Definition of capacity" or "Basis of adjustment" in the appropriate International Standards.

Always clean volumetric instruments before use (see 7.3) and check the jet for possible damage and unrestricted outflow of liquid with volumetric instruments adjusted to deliver.

ISO 4787:2010(E)

According to 7.5, the delivered volume of liquid with instruments adjusted to deliver depends on the delivery time (specified in the appropriate standards) and physical properties of the liquid. Dilute aqueous solutions, however, such as are ordinarily employed in volumetric analysis, can be used without significant error; for example 1 mol/l solutions introduce errors smaller than Class A and Class AS tolerances and 0,1 mol/l solutions introduce correspondingly smaller errors. The accuracy deteriorates when using liquids with a viscosity and/or surface tension very different from water, e.g. non-aqueous liquids.

Liquids which are too opaque for the bottom of the meniscus to be visible may be read on the "upper edge" of the meniscus, with rather less accuracy and precision than is possible when viewing the lowest point of the meniscus.

The temperature of use is also important. Whereas the expansion of the volumetric instrument itself is negligible (see 7.2.1.2), the expansion of liquid shall be considered. Ensure that all solutions used in connection with each other are close to a common (everyday) temperature when their volumes are measured. Especially when preparing standard solutions, pipetting of the sample, and for example titration, should be as close as possible to the same temperature. Avoid large difference in temperatures between the instrument and the liquid (see 7.2.2).

2 Volumetric flasks (see ISO 1042)

The procedure for setting of the meniscus on the ring mark shall reproduce the conditions of calibration and is illustrated by the following example in the case of a dilute aqueous solution.

Introduce the solid material and add sufficient water to dissolve it by carefully swaying the flask without contaminating the surface above the graduation line. (If necessary, this process can be assisted by no more than moderate warming.)

Then, while still swaying the flask to mix its content, add more water to bring the liquid surface to within a few centimetres below the graduation line.

Stopper and shake the flask upside down to mix the contents, then carefully remove and rinse the stopper, gathering the water in the flask to bring the liquid surface to within 1 cm below the graduation line.

Leave the flask to stand without its stopper for 2 min to allow the liquid in the neck to drain. If necessary, wait for the solution to regain room temperature. During the waiting time, the rinsed and dried stopper may be replaced.

Then set the bottom of the meniscus on the graduation line by running the necessary water down the neck from a point less than 1 cm above the graduation line.

Finally, stopper and shake the volumetric flask by multiple inversions for thorough mixing.

3 Measuring cylinders (see ISO 4788)

To set the meniscus precisely, fill the cylinder with the relevant liquid to a few millimetres above the nominal capacity line or selected graduation line. Wait 2 min to allow liquid in the cylinder to drain. Then withdraw the surplus of liquid by means of a tube drawn out to a jet.

4 Burettes (see ISO 385)

After rinsing with the liquid or reagent to be used, prime the stopcock and fill the burette, clamped in a vertical position, a few millimetres above the zero graduation line. Wait 2 min for drainage before setting the meniscus at the zero line. Now, titration can be performed until the endpoint is reached. The meniscus reading at the relevant graduation line gives the amount of volume that has been delivered.

In practice, a burette is generally not employed in the same way as it is tested. Typically, in use, the approach to the finally desired delivery point is made dropwise, to avoid overdelivery, and frequently takes a period of time that is similar to, or even greater than, any specified waiting time observed during testing. Therefore, it follows that in use, the waiting time, if specified, need generally not be observed.

10.5 Pipettes

WARNING — Use an appropriate pipetting aid for filling to avoid any danger to the operator. Always hold the pipette at the top while inserting in the aspiration adapter because pipettes in particular can break and cause injury. It is recommended to use pipetting aids which allow the unrestricted outflow of the liquid.

10.5.1 Pipettes adjusted to deliver (see ISO 648 and ISO 835)

After rinsing with the liquid or reagent to be used, fill the pipette by suction to a few millimetres above the selected graduation line. Remove any liquid remaining on the outside of the jet.

The final setting of the meniscus shall then be made by dispensing the surplus liquid through the jet. Remove any drops of liquid adhering to the jet by bringing an inclined ground glass vessel into contact with the tip of the jet. Delivery shall then be made with the tip of the jet in contact with the inner surface of the inclined receiving vessel.

If the setting after delivery is done at a lower graduation line, the liquid flow has to be nearly stopped a few millimetres above the graduation line. After observing a waiting time, if specified, complete the final setting quickly.

A waiting time, if specified, shall be observed before making the final setting for delivery of a given volume.

10.5.2 Pipettes adjusted to contain

Rinse the pipette with the reagent to be used to a few millimetres below the desired graduation line. Fill the pipette by suction to as close as possible above the selected graduation line. Remove any liquid remaining on the outside of the jet. Make the final setting of the meniscus to the line by withdrawing the surplus liquid by means of filter paper. For the discharge, rinse the pipette several times with the diluting medium.

Annex A (informative)

Cleaning of volumetric glassware

The volume contained in or delivered from volumetric glassware depends on cleanliness of the entire internal surface to ensure uniform wetting and performing a well shaped meniscus.

Glassware can be cleaned manually, in an immersion bath or in a laboratory washing machine. To reduce volume changes through glass erosion and destruction of graduations, gentle cleaning with detergents of low alkalinity at temperatures below 70 °C with short contact time and whenever possible immediately after use is recommended. The cleanliness of the inner glass surface should be ascertained as specified in 7.3.

If the inner glass walls are not sufficiently clean after the above treatment, the volumetric instrument should be filled with a mixture of equal parts of a 30 g/l solution of potassium permanganate (KMnO_4) and mol/l solution of sodium hydroxide (NaOH). After about 2 h, a residue of MnO_2 may be removed by means of dilute hydrochloric acid or oxalic acid.

The volumetric instrument should then be rinsed with distilled water and it should again be ascertained that the walls are sufficiently clean. If they are not, the procedure should be repeated. If this treatment is not successful, specific cleaning methods described in laboratory handbooks should be applied. The method shall not change the volume of the instrument.

As a safeguard, it is recommended that volumetric instruments should not be heated to a temperature considerably above 180 °C. Although the strain point of glasses used for volumetric purposes is in the range of 500 °C, alterations of volume might occur at temperatures considerably below the strain point.

Annex B (normative)

Calculation of volume

B.1 General calculation

B.1.1 The general equation for calculation of the volume at the reference temperature of 20 °C, V_{20} (at a reference temperature of 27 °C, V_{27}), from the apparent mass of the water, contained or delivered, is as follows:

$$V_{20} = (I_L - I_E) \times (\rho_W - \rho_A)^{-1} \times \left(1 - \frac{\rho_A}{\rho_B}\right) \times [1 - \gamma(t - 20)] \quad (\text{B.1})$$

where

I_L is the balance reading of vessel with water, in grams;

I_E is the balance reading of empty vessel, in grams (zero in case the balance was tared with the volumetric instrument or receiving vessel);

ρ_A is the density of air, in grams per millilitre, obtained from Table B.3 at the temperature and atmospheric pressure of the test;

ρ_B is either the actual density of the balance weights when these are adjusted to their nominal mass, or the reference density for which the weights have been adjusted (see the note below), in grams per millilitre, or, when using an electronic balance without weights, the (reference) density of the weights with which it has been adjusted;

NOTE Weights conforming to International Document OIML D 28 of the International Organization of Legal Metrology have been adjusted to give correct results when weighing in air as though the density of the weights were 8,0 g/ml. Electronic balances are usually adjusted by means of these weights.

ρ_W is the density of water at t °C, in grams per millilitre, calculated with the “Tanaka” formula (see Table B.4);

γ is the coefficient of cubical thermal expansion of the material of which the volumetric instrument tested is made, in reciprocal degrees Celsius (see Table B.5);

t is the temperature of the water used in testing, in degrees Celsius.

B.1.2 In order to give an impression of the extent to which the various parameters influence the result, some parametric tolerances, with the corresponding error in the volume determined, are given in Table B.1. It is evident from these figures that the measurement of the water temperature is the most critical factor.

Table B.1 — Examples for volumetric errors

| Parameter | Parametric tolerance | Volumetric error relative to the volume ^a |
|---|----------------------|--|
| Water temperature | ±0,5 °C | ±10 ⁻⁴ |
| Air pressure | ±8 mbar (0,8 kPa) | ±10 ⁻⁵ |
| Air temperature | ±2,5 °C | ±10 ⁻⁵ |
| Relative humidity | ±10 % | ±10 ⁻⁶ |
| Density of weights | ±0,6 g/ml | ±10 ⁻⁵ |
| ^a Example: a relative volumetric error of ±10 ⁻⁴ to the measured volume of 100 ml would be 0,01 ml. | | |

3 The largest source of experimental error associated with the determination of volume is in the setting of the meniscus which will depend on operator care, and is related to the cross-section of the tubing where the meniscus is located. Some typical values are given in Table B.2.

Table B.2 — Error relating to the setting of meniscus

| Error in meniscus position mm | Volume error in µl at neck diameter | | | |
|----------------------------------|-------------------------------------|-------|-------|-------|
| | 5 mm | 10 mm | 20 mm | 30 mm |
| 0,05 | 1 | 4 | 16 | 35 |
| 0,1 | 2 | 8 | 31 | 71 |
| 0,5 | 10 | 39 | 157 | 353 |
| 1 | 20 | 78 | 314 | 707 |
| 2 | 39 | 157 | 628 | 1 414 |

4 When the temperature at which the volumetric instrument is used (t_2) differs from the reference temperature (t_1), the volume of the volumetric instrument at (t_2) can be calculated from the following equation:

$$Vt_2 = Vt_1 [1 + \gamma(t_2 - t_1)] \quad (\text{B.2})$$

where γ is the coefficient of cubical thermal expansion (see Table B.5). For information on the effect of temperature differences, see 7.2.1.2.

Tables for calculation

1 To facilitate an easy calculation of the instrument's volume V_{20} at a reference temperature of 20 °C from the apparent mass obtained by using a balance, a factor Z can be introduced in Equation (B.1):

$$V_{20} = (I_L - I_E) \times Z \quad (\text{B.3})$$

Tables B.6, B.7 and B.8 give factor Z conversion values for different types of glass at common air pressure versus temperature. In these tables, the combined effects of the density of the water, the thermal expansion of the glass and the air buoyancy have been taken into account. The used balance weight is $\rho_B = 8,0$ g/ml.

The factor Z conversion values have been derived from Equation (B.1) as follows:

$$Z = (\rho_W - \rho_A)^{-1} \times \left(1 - \frac{\rho_A}{\rho_B} \right) \times [1 - \gamma(t - 20)] \quad (\text{B.4})$$

B.2.2 If the general Equation (B.1) is used for calculation of volume, Tables B.3, B.4 and B.5 list the necessary values for ρ_A , ρ_W and γ .

The density of air in Table B.3 is given for a relative humidity of 50 % and a content of 0,04 % by volume carbon dioxide. In practice, usual deviations from these conditions, e.g. a relative humidity in the range of 35 % to 85 %, will introduce negligible error without significance for the purposes of this International Standard.

The density of water in Table B.4 is based on Tanaka *et al.*, see Reference [5].

Table B.3 — Density of air^a

Density values in 10³ grams per millilitre

| Temperature °C | Air pressure hPa | | | | | | | | |
|-------------------|---------------------|-------|-------|-------|-------|-------|-------|-------|-------|
| | 930 | 940 | 950 | 960 | 970 | 980 | 990 | 1 000 | 1 010 |
| 10,0 | 1,142 | 1,154 | 1,166 | 1,179 | 1,191 | 1,203 | 1,216 | 1,228 | 1,240 |
| 11,0 | 1,138 | 1,150 | 1,162 | 1,174 | 1,187 | 1,199 | 1,211 | 1,223 | 1,236 |
| 12,0 | 1,133 | 1,146 | 1,158 | 1,170 | 1,182 | 1,194 | 1,207 | 1,219 | 1,231 |
| 13,0 | 1,129 | 1,141 | 1,154 | 1,166 | 1,178 | 1,190 | 1,202 | 1,214 | 1,227 |
| 14,0 | 1,125 | 1,137 | 1,149 | 1,161 | 1,174 | 1,186 | 1,198 | 1,210 | 1,222 |
| 15,0 | 1,121 | 1,133 | 1,145 | 1,157 | 1,169 | 1,181 | 1,193 | 1,206 | 1,218 |
| 16,0 | 1,117 | 1,129 | 1,141 | 1,153 | 1,165 | 1,177 | 1,189 | 1,201 | 1,213 |
| 17,0 | 1,108 | 1,120 | 1,132 | 1,144 | 1,156 | 1,168 | 1,180 | 1,192 | 1,204 |
| 18,0 | 1,108 | 1,120 | 1,132 | 1,144 | 1,156 | 1,168 | 1,180 | 1,192 | 1,204 |
| 19,0 | 1,104 | 1,116 | 1,128 | 1,140 | 1,152 | 1,164 | 1,176 | 1,188 | 1,200 |
| 20,0 | 1,100 | 1,112 | 1,124 | 1,136 | 1,148 | 1,160 | 1,172 | 1,183 | 1,195 |
| 21,0 | 1,096 | 1,108 | 1,120 | 1,132 | 1,144 | 1,155 | 1,167 | 1,179 | 1,191 |
| 22,0 | 1,092 | 1,104 | 1,116 | 1,128 | 1,139 | 1,151 | 1,163 | 1,175 | 1,187 |
| 23,0 | 1,088 | 1,100 | 1,112 | 1,123 | 1,135 | 1,147 | 1,159 | 1,170 | 1,182 |
| 24,0 | 1,084 | 1,096 | 1,107 | 1,119 | 1,131 | 1,143 | 1,154 | 1,166 | 1,178 |
| 25,0 | 1,080 | 1,092 | 1,103 | 1,115 | 1,127 | 1,138 | 1,150 | 1,162 | 1,173 |
| 26,0 | 1,076 | 1,088 | 1,099 | 1,111 | 1,122 | 1,134 | 1,146 | 1,157 | 1,169 |
| 27,0 | 1,072 | 1,083 | 1,095 | 1,107 | 1,118 | 1,130 | 1,141 | 1,153 | 1,165 |
| 28,0 | 1,068 | 1,079 | 1,091 | 1,103 | 1,114 | 1,126 | 1,137 | 1,149 | 1,160 |
| 29,0 | 1,064 | 1,075 | 1,087 | 1,098 | 1,110 | 1,121 | 1,133 | 1,144 | 1,156 |
| 30,0 | 1,060 | 1,071 | 1,083 | 1,094 | 1,106 | 1,117 | 1,129 | 1,140 | 1,152 |

^a Density of air for a relative humidity of 50 % and 0,04 % CO₂ (by volume). Details see B.2.2.

Table B.4 — Density of air-free water^a

| Temperature <i>t</i> °C | Density ρ_W g/ml |
|----------------------------|--------------------------|
| 15 | 0,99 909 |
| 16 | 0,99 894 |
| 17 | 0,99 877 |
| 18 | 0,99 859 |
| 19 | 0,99 840 |
| 20 | 0,99 820 |
| 21 | 0,99 799 |
| 22 | 0,99 776 |
| 23 | 0,99 753 |
| 24 | 0,99 729 |
| 25 | 0,99 704 |
| 26 | 0,99 678 |
| 27 | 0,99 651 |
| 28 | 0,99 623 |
| 29 | 0,99 594 |
| 30 | 0,99 564 |
| 31 | 0,99 533 |
| 32 | 0,99 502 |
| 33 | 0,99 470 |
| 34 | 0,99 436 |
| 35 | 0,99 403 |

^a Reference see B.2.2.

Table B.5 — Coefficient of cubical thermal expansion, γ

| Material | Coefficient of cubical thermal expansion, γ^a °C ⁻¹ × 10 ⁻⁶ |
|------------------------|--|
| Borosilicate glass 3.3 | 9,9 |
| Borosilicate glass 5.0 | 15 |
| Soda-lime glass | 27 |

^a $\gamma = 3 \alpha$, where α is the coefficient of linear thermal expansion.

Table B.6 — Factor *Z* for borosilicate glass 3.3*Z* values in microlitres per milligram

| Temperature °C | Air pressure | | | | | | | |
|-------------------|--------------|----------|----------|----------|----------|----------|----------|----------|
| | hPa | | | | | | | |
| | 850 | 880 | 910 | 940 | 970 | 1 000 | 1 030 | 1 060 |
| 15,0 | 1,001 85 | 1,001 88 | 1,001 91 | 1,001 95 | 1,001 98 | 1,002 01 | 1,002 04 | 1,002 07 |
| 15,2 | 1,001 88 | 1,001 91 | 1,001 94 | 1,001 97 | 1,002 01 | 1,002 04 | 1,002 07 | 1,002 10 |
| 15,4 | 1,001 91 | 1,001 94 | 1,001 97 | 1,002 00 | 1,002 03 | 1,002 07 | 1,002 10 | 1,002 13 |
| 15,6 | 1,001 94 | 1,001 97 | 1,002 00 | 1,002 03 | 1,002 06 | 1,002 09 | 1,002 13 | 1,002 16 |
| 15,8 | 1,001 96 | 1,002 00 | 1,002 03 | 1,002 06 | 1,002 09 | 1,002 12 | 1,002 16 | 1,002 19 |
| 16,0 | 1,001 99 | 1,002 03 | 1,002 06 | 1,002 09 | 1,002 12 | 1,002 15 | 1,002 18 | 1,002 22 |
| 16,2 | 1,002 02 | 1,002 06 | 1,002 09 | 1,002 12 | 1,002 15 | 1,002 18 | 1,002 21 | 1,002 25 |
| 16,4 | 1,002 05 | 1,002 09 | 1,002 12 | 1,002 15 | 1,002 18 | 1,002 21 | 1,002 25 | 1,002 28 |
| 16,6 | 1,002 09 | 1,002 12 | 1,002 15 | 1,002 18 | 1,002 21 | 1,002 24 | 1,002 28 | 1,002 31 |
| 16,8 | 1,002 12 | 1,002 15 | 1,002 18 | 1,002 21 | 1,002 24 | 1,002 28 | 1,002 31 | 1,002 34 |
| 17,0 | 1,002 15 | 1,002 18 | 1,002 21 | 1,002 24 | 1,002 28 | 1,002 31 | 1,002 34 | 1,002 37 |
| 17,2 | 1,002 18 | 1,002 21 | 1,002 25 | 1,002 28 | 1,002 31 | 1,002 34 | 1,002 37 | 1,002 40 |
| 17,4 | 1,002 22 | 1,002 25 | 1,002 28 | 1,002 31 | 1,002 34 | 1,002 37 | 1,002 41 | 1,002 44 |
| 17,6 | 1,002 25 | 1,002 28 | 1,002 31 | 1,002 34 | 1,002 38 | 1,002 41 | 1,002 44 | 1,002 47 |
| 17,8 | 1,002 28 | 1,002 31 | 1,002 35 | 1,002 38 | 1,002 41 | 1,002 44 | 1,002 47 | 1,002 50 |
| 18,0 | 1,002 32 | 1,002 35 | 1,002 38 | 1,002 41 | 1,002 44 | 1,002 47 | 1,002 51 | 1,002 54 |
| 18,2 | 1,002 35 | 1,002 38 | 1,002 41 | 1,002 45 | 1,002 48 | 1,002 51 | 1,002 54 | 1,002 57 |
| 18,4 | 1,002 39 | 1,002 42 | 1,002 45 | 1,002 48 | 1,002 51 | 1,002 54 | 1,002 58 | 1,002 61 |
| 18,6 | 1,002 42 | 1,002 45 | 1,002 49 | 1,002 52 | 1,002 55 | 1,002 58 | 1,002 61 | 1,002 64 |
| 18,8 | 1,002 46 | 1,002 49 | 1,002 52 | 1,002 55 | 1,002 58 | 1,002 62 | 1,002 65 | 1,002 68 |
| 19,0 | 1,002 49 | 1,002 53 | 1,002 56 | 1,002 59 | 1,002 62 | 1,002 65 | 1,002 68 | 1,002 72 |
| 19,2 | 1,002 53 | 1,002 56 | 1,002 59 | 1,002 63 | 1,002 66 | 1,002 69 | 1,002 72 | 1,002 75 |
| 19,4 | 1,002 57 | 1,002 60 | 1,002 63 | 1,002 66 | 1,002 70 | 1,002 73 | 1,002 76 | 1,002 79 |
| 19,6 | 1,002 61 | 1,002 64 | 1,002 67 | 1,002 70 | 1,002 73 | 1,002 76 | 1,002 80 | 1,002 83 |
| 19,8 | 1,002 65 | 1,002 68 | 1,002 71 | 1,002 74 | 1,002 77 | 1,002 80 | 1,002 83 | 1,002 87 |
| 20,0 | 1,002 68 | 1,002 72 | 1,002 75 | 1,002 78 | 1,002 81 | 1,002 84 | 1,002 87 | 1,002 90 |
| 20,2 | 1,002 72 | 1,002 75 | 1,002 79 | 1,002 82 | 1,002 85 | 1,002 88 | 1,002 91 | 1,002 94 |
| 20,4 | 1,002 76 | 1,002 79 | 1,002 83 | 1,002 86 | 1,002 89 | 1,002 92 | 1,002 95 | 1,002 98 |
| 20,6 | 1,002 80 | 1,002 83 | 1,002 87 | 1,002 90 | 1,002 93 | 1,002 96 | 1,002 99 | 1,003 02 |
| 20,8 | 1,002 84 | 1,002 87 | 1,002 91 | 1,002 94 | 1,002 97 | 1,003 00 | 1,003 03 | 1,003 06 |
| 21,0 | 1,002 88 | 1,002 92 | 1,002 95 | 1,002 98 | 1,003 01 | 1,003 04 | 1,003 07 | 1,003 10 |
| 21,2 | 1,002 92 | 1,002 96 | 1,002 99 | 1,003 02 | 1,003 05 | 1,003 08 | 1,003 11 | 1,003 14 |
| 21,4 | 1,002 97 | 1,003 00 | 1,003 03 | 1,003 06 | 1,003 09 | 1,003 12 | 1,003 15 | 1,003 19 |
| 21,6 | 1,003 01 | 1,003 04 | 1,003 07 | 1,003 10 | 1,003 13 | 1,003 16 | 1,003 20 | 1,003 23 |
| 21,8 | 1,003 05 | 1,003 08 | 1,003 11 | 1,003 14 | 1,003 18 | 1,003 21 | 1,003 24 | 1,003 27 |
| 22,0 | 1,003 09 | 1,003 13 | 1,003 16 | 1,003 19 | 1,003 22 | 1,003 25 | 1,003 28 | 1,003 31 |
| 22,2 | 1,003 14 | 1,003 17 | 1,003 20 | 1,003 23 | 1,003 26 | 1,003 29 | 1,003 32 | 1,003 36 |
| 22,4 | 1,003 18 | 1,003 21 | 1,003 24 | 1,003 27 | 1,003 31 | 1,003 34 | 1,003 37 | 1,003 40 |

Table B.6 (continued)

Z values in microlitres per milligram

| Temperature °C | Air pressure hPa | | | | | | | |
|-------------------|---------------------|----------|----------|----------|----------|----------|----------|----------|
| | 850 | 880 | 910 | 940 | 970 | 1 000 | 1 030 | 1 060 |
| 22,6 | 1,003 22 | 1,003 26 | 1,003 29 | 1,003 32 | 1,003 35 | 1,003 38 | 1,003 41 | 1,003 44 |
| 22,8 | 1,003 27 | 1,003 30 | 1,003 33 | 1,003 36 | 1,003 39 | 1,003 43 | 1,003 46 | 1,003 49 |
| 23,0 | 1,003 31 | 1,003 35 | 1,003 38 | 1,003 41 | 1,003 44 | 1,003 47 | 1,003 50 | 1,003 53 |
| 23,2 | 1,003 36 | 1,003 39 | 1,003 42 | 1,003 45 | 1,003 48 | 1,003 52 | 1,003 55 | 1,003 58 |
| 23,4 | 1,003 41 | 1,003 44 | 1,003 47 | 1,003 50 | 1,003 53 | 1,003 56 | 1,003 59 | 1,003 62 |
| 23,6 | 1,003 45 | 1,003 48 | 1,003 51 | 1,003 54 | 1,003 58 | 1,003 61 | 1,003 64 | 1,003 67 |
| 23,8 | 1,003 50 | 1,003 53 | 1,003 56 | 1,003 59 | 1,003 62 | 1,003 65 | 1,003 68 | 1,003 72 |
| 24,0 | 1,003 54 | 1,003 58 | 1,003 61 | 1,003 64 | 1,003 67 | 1,003 70 | 1,003 73 | 1,003 76 |
| 24,2 | 1,003 59 | 1,003 62 | 1,003 65 | 1,003 69 | 1,003 72 | 1,003 75 | 1,003 78 | 1,003 81 |
| 24,4 | 1,003 64 | 1,003 67 | 1,003 70 | 1,003 73 | 1,003 76 | 1,003 79 | 1,003 83 | 1,003 86 |
| 24,6 | 1,003 69 | 1,003 72 | 1,003 75 | 1,003 78 | 1,003 81 | 1,003 84 | 1,003 87 | 1,003 90 |
| 24,8 | 1,003 74 | 1,003 77 | 1,003 80 | 1,003 83 | 1,003 86 | 1,003 89 | 1,003 92 | 1,003 95 |
| 25,0 | 1,003 79 | 1,003 82 | 1,003 85 | 1,003 88 | 1,003 91 | 1,003 94 | 1,003 97 | 1,004 00 |
| 25,2 | 1,003 83 | 1,003 87 | 1,003 90 | 1,003 93 | 1,003 96 | 1,003 99 | 1,004 02 | 1,004 05 |
| 25,4 | 1,003 88 | 1,003 92 | 1,003 95 | 1,003 98 | 1,004 01 | 1,004 04 | 1,004 07 | 1,004 10 |
| 25,6 | 1,003 93 | 1,003 97 | 1,004 00 | 1,004 03 | 1,004 06 | 1,004 09 | 1,004 12 | 1,004 15 |
| 25,8 | 1,003 98 | 1,004 02 | 1,004 05 | 1,004 08 | 1,004 11 | 1,004 14 | 1,004 17 | 1,004 20 |
| 26,0 | 1,004 04 | 1,004 07 | 1,004 10 | 1,004 13 | 1,004 16 | 1,004 19 | 1,004 22 | 1,004 25 |
| 26,2 | 1,004 09 | 1,004 12 | 1,004 15 | 1,004 18 | 1,004 21 | 1,004 24 | 1,004 27 | 1,004 30 |
| 26,4 | 1,004 14 | 1,004 17 | 1,004 20 | 1,004 23 | 1,004 26 | 1,004 29 | 1,004 32 | 1,004 35 |
| 26,6 | 1,004 19 | 1,004 22 | 1,004 25 | 1,004 28 | 1,004 31 | 1,004 34 | 1,004 38 | 1,004 41 |
| 26,8 | 1,004 24 | 1,004 27 | 1,004 30 | 1,004 33 | 1,004 37 | 1,004 40 | 1,004 43 | 1,004 46 |
| 27,0 | 1,004 30 | 1,004 33 | 1,004 36 | 1,004 39 | 1,004 42 | 1,004 45 | 1,004 48 | 1,004 51 |
| 27,2 | 1,004 35 | 1,004 38 | 1,004 41 | 1,004 44 | 1,004 47 | 1,004 50 | 1,004 53 | 1,004 56 |
| 27,4 | 1,004 40 | 1,004 43 | 1,004 46 | 1,004 49 | 1,004 52 | 1,004 56 | 1,004 59 | 1,004 62 |
| 27,6 | 1,004 46 | 1,004 49 | 1,004 52 | 1,004 55 | 1,004 58 | 1,004 61 | 1,004 64 | 1,004 67 |
| 27,8 | 1,004 51 | 1,004 54 | 1,004 57 | 1,004 60 | 1,004 63 | 1,004 66 | 1,004 69 | 1,004 72 |
| 28,0 | 1,004 56 | 1,004 60 | 1,004 63 | 1,004 66 | 1,004 69 | 1,004 72 | 1,004 75 | 1,004 78 |
| 28,2 | 1,004 62 | 1,004 65 | 1,004 68 | 1,004 71 | 1,004 74 | 1,004 77 | 1,004 80 | 1,004 83 |
| 28,4 | 1,004 67 | 1,004 71 | 1,004 74 | 1,004 77 | 1,004 80 | 1,004 83 | 1,004 86 | 1,004 89 |
| 28,6 | 1,004 73 | 1,004 76 | 1,004 79 | 1,004 82 | 1,004 85 | 1,004 88 | 1,004 91 | 1,004 94 |
| 28,8 | 1,004 79 | 1,004 82 | 1,004 85 | 1,004 88 | 1,004 91 | 1,004 94 | 1,004 97 | 1,005 00 |
| 29,0 | 1,004 84 | 1,004 87 | 1,004 90 | 1,004 93 | 1,004 97 | 1,005 00 | 1,005 03 | 1,005 06 |
| 29,2 | 1,004 90 | 1,004 93 | 1,004 96 | 1,004 99 | 1,005 02 | 1,005 05 | 1,005 08 | 1,005 11 |
| 29,4 | 1,004 96 | 1,004 99 | 1,005 02 | 1,005 05 | 1,005 08 | 1,005 11 | 1,005 14 | 1,005 17 |
| 29,6 | 1,005 01 | 1,005 04 | 1,005 08 | 1,005 11 | 1,005 14 | 1,005 17 | 1,005 20 | 1,005 23 |
| 29,8 | 1,005 07 | 1,005 10 | 1,005 13 | 1,005 16 | 1,005 19 | 1,005 22 | 1,005 26 | 1,005 29 |
| 30,0 | 1,005 13 | 1,005 16 | 1,005 19 | 1,005 22 | 1,005 25 | 1,005 28 | 1,005 31 | 1,005 34 |

Table B.7 — Factor *Z* for borosilicate glass 5.0*Z* values in microlitres per milligram

| Temperature °C | Air pressure | | | | | | | |
|-------------------|--------------|----------|----------|----------|----------|----------|----------|----------|
| | hPa | | | | | | | |
| | 850 | 880 | 910 | 940 | 970 | 1 000 | 1 030 | 1 060 |
| 15,0 | 1,001 88 | 1,001 91 | 1,001 94 | 1,001 97 | 1,002 00 | 1,002 03 | 1,002 07 | 1,002 10 |
| 15,2 | 1,001 90 | 1,001 93 | 1,001 97 | 1,002 00 | 1,002 03 | 1,002 06 | 1,002 09 | 1,002 13 |
| 15,4 | 1,001 93 | 1,001 96 | 1,001 99 | 1,002 03 | 1,002 06 | 1,002 09 | 1,002 12 | 1,002 15 |
| 15,6 | 1,001 96 | 1,001 99 | 1,002 02 | 1,002 05 | 1,002 08 | 1,002 12 | 1,002 15 | 1,002 18 |
| 15,8 | 1,001 99 | 1,002 02 | 1,002 05 | 1,002 08 | 1,002 11 | 1,002 14 | 1,002 18 | 1,002 21 |
| 16,0 | 1,002 01 | 1,002 05 | 1,002 08 | 1,002 11 | 1,002 14 | 1,002 17 | 1,002 21 | 1,002 24 |
| 16,2 | 1,002 04 | 1,002 08 | 1,002 11 | 1,002 14 | 1,002 17 | 1,002 20 | 1,002 23 | 1,002 27 |
| 16,4 | 1,002 07 | 1,002 11 | 1,002 14 | 1,002 17 | 1,002 20 | 1,002 23 | 1,002 26 | 1,002 30 |
| 16,6 | 1,002 10 | 1,002 14 | 1,002 17 | 1,002 20 | 1,002 23 | 1,002 26 | 1,002 29 | 1,002 33 |
| 16,8 | 1,002 13 | 1,002 17 | 1,002 20 | 1,002 23 | 1,002 26 | 1,002 29 | 1,002 32 | 1,002 36 |
| 17,0 | 1,002 17 | 1,002 20 | 1,002 23 | 1,002 26 | 1,002 29 | 1,002 32 | 1,002 36 | 1,002 39 |
| 17,2 | 1,002 20 | 1,002 23 | 1,002 26 | 1,002 29 | 1,002 32 | 1,002 35 | 1,002 39 | 1,002 42 |
| 17,4 | 1,002 23 | 1,002 26 | 1,002 29 | 1,002 32 | 1,002 36 | 1,002 39 | 1,002 42 | 1,002 45 |
| 17,6 | 1,002 26 | 1,002 29 | 1,002 32 | 1,002 36 | 1,002 39 | 1,002 42 | 1,002 45 | 1,002 48 |
| 17,8 | 1,002 29 | 1,002 33 | 1,002 36 | 1,002 39 | 1,002 42 | 1,002 45 | 1,002 48 | 1,002 51 |
| 18,0 | 1,002 33 | 1,002 36 | 1,002 39 | 1,002 42 | 1,002 45 | 1,002 48 | 1,002 52 | 1,002 55 |
| 18,2 | 1,002 36 | 1,002 39 | 1,002 42 | 1,002 46 | 1,002 49 | 1,002 52 | 1,002 55 | 1,002 58 |
| 18,4 | 1,002 39 | 1,002 43 | 1,002 46 | 1,002 49 | 1,002 52 | 1,002 55 | 1,002 58 | 1,002 62 |
| 18,6 | 1,002 43 | 1,002 46 | 1,002 49 | 1,002 52 | 1,002 56 | 1,002 59 | 1,002 62 | 1,002 65 |
| 18,8 | 1,002 46 | 1,002 50 | 1,002 53 | 1,002 56 | 1,002 59 | 1,002 62 | 1,002 65 | 1,002 69 |
| 19,0 | 1,002 50 | 1,002 53 | 1,002 56 | 1,002 59 | 1,002 63 | 1,002 66 | 1,002 69 | 1,002 72 |
| 19,2 | 1,002 54 | 1,002 57 | 1,002 60 | 1,002 63 | 1,002 66 | 1,002 69 | 1,002 72 | 1,002 76 |
| 19,4 | 1,002 57 | 1,002 60 | 1,002 64 | 1,002 67 | 1,002 70 | 1,002 73 | 1,002 76 | 1,002 79 |
| 19,6 | 1,002 61 | 1,002 64 | 1,002 67 | 1,002 70 | 1,002 73 | 1,002 77 | 1,002 80 | 1,002 83 |
| 19,8 | 1,002 65 | 1,002 68 | 1,002 71 | 1,002 74 | 1,002 77 | 1,002 80 | 1,002 83 | 1,002 87 |
| 20,0 | 1,002 68 | 1,002 72 | 1,002 75 | 1,002 78 | 1,002 81 | 1,002 84 | 1,002 87 | 1,002 90 |
| 20,2 | 1,002 72 | 1,002 75 | 1,002 78 | 1,002 82 | 1,002 85 | 1,002 88 | 1,002 91 | 1,002 94 |
| 20,4 | 1,002 76 | 1,002 79 | 1,002 82 | 1,002 85 | 1,002 89 | 1,002 92 | 1,002 95 | 1,002 98 |
| 20,6 | 1,002 80 | 1,002 83 | 1,002 86 | 1,002 89 | 1,002 92 | 1,002 96 | 1,002 99 | 1,003 02 |
| 20,8 | 1,002 84 | 1,002 87 | 1,002 90 | 1,002 93 | 1,002 96 | 1,003 00 | 1,003 03 | 1,003 06 |
| 21,0 | 1,002 88 | 1,002 91 | 1,002 94 | 1,002 97 | 1,003 00 | 1,003 04 | 1,003 07 | 1,003 10 |
| 21,2 | 1,002 92 | 1,002 95 | 1,002 98 | 1,003 01 | 1,003 04 | 1,003 08 | 1,003 11 | 1,003 14 |
| 21,4 | 1,002 96 | 1,002 99 | 1,003 02 | 1,003 05 | 1,003 08 | 1,003 12 | 1,003 15 | 1,003 18 |
| 21,6 | 1,003 00 | 1,003 03 | 1,003 06 | 1,003 09 | 1,003 13 | 1,003 16 | 1,003 19 | 1,003 22 |
| 21,8 | 1,003 04 | 1,003 07 | 1,003 10 | 1,003 14 | 1,003 17 | 1,003 20 | 1,003 23 | 1,003 26 |
| 22,0 | 1,003 08 | 1,003 11 | 1,003 15 | 1,003 18 | 1,003 21 | 1,003 24 | 1,003 27 | 1,003 30 |
| 22,2 | 1,003 13 | 1,003 16 | 1,003 19 | 1,003 22 | 1,003 25 | 1,003 28 | 1,003 31 | 1,003 34 |
| 22,4 | 1,003 17 | 1,003 20 | 1,003 23 | 1,003 26 | 1,003 29 | 1,003 32 | 1,003 36 | 1,003 39 |

Table B.7 (continued)

Z values in microlitres per milligram

| Temperature °C | Air pressure hPa | | | | | | | |
|-------------------|---------------------|----------|----------|----------|----------|----------|----------|----------|
| | 850 | 880 | 910 | 940 | 970 | 1 000 | 1 030 | 1 060 |
| 22,6 | 1,003 21 | 1,003 24 | 1,003 27 | 1,003 31 | 1,003 34 | 1,003 37 | 1,003 40 | 1,003 43 |
| 22,8 | 1,003 26 | 1,003 29 | 1,003 32 | 1,003 35 | 1,003 38 | 1,003 41 | 1,003 44 | 1,003 47 |
| 23,0 | 1,003 30 | 1,003 33 | 1,003 36 | 1,003 39 | 1,003 42 | 1,003 45 | 1,003 49 | 1,003 52 |
| 23,2 | 1,003 34 | 1,003 37 | 1,003 41 | 1,003 44 | 1,003 47 | 1,003 50 | 1,003 53 | 1,003 56 |
| 23,4 | 1,003 39 | 1,003 42 | 1,003 45 | 1,003 48 | 1,003 51 | 1,003 54 | 1,003 57 | 1,003 61 |
| 23,6 | 1,003 43 | 1,003 46 | 1,003 50 | 1,003 53 | 1,003 56 | 1,003 59 | 1,003 62 | 1,003 65 |
| 23,8 | 1,003 48 | 1,003 51 | 1,003 54 | 1,003 57 | 1,003 60 | 1,003 63 | 1,003 66 | 1,003 70 |
| 24,0 | 1,003 52 | 1,003 56 | 1,003 59 | 1,003 62 | 1,003 65 | 1,003 68 | 1,003 71 | 1,003 74 |
| 24,2 | 1,003 57 | 1,003 60 | 1,003 63 | 1,003 66 | 1,003 69 | 1,003 73 | 1,003 76 | 1,003 79 |
| 24,4 | 1,003 62 | 1,003 65 | 1,003 68 | 1,003 71 | 1,003 74 | 1,003 77 | 1,003 80 | 1,003 83 |
| 24,6 | 1,003 66 | 1,003 70 | 1,003 73 | 1,003 76 | 1,003 79 | 1,003 82 | 1,003 85 | 1,003 88 |
| 24,8 | 1,003 71 | 1,003 74 | 1,003 77 | 1,003 80 | 1,003 84 | 1,003 87 | 1,003 90 | 1,003 93 |
| 25,0 | 1,003 76 | 1,003 79 | 1,003 82 | 1,003 85 | 1,003 88 | 1,003 91 | 1,003 95 | 1,003 98 |
| 25,2 | 1,003 81 | 1,003 84 | 1,003 87 | 1,003 90 | 1,003 93 | 1,003 96 | 1,003 99 | 1,004 02 |
| 25,4 | 1,003 86 | 1,003 89 | 1,003 92 | 1,003 95 | 1,003 98 | 1,004 01 | 1,004 04 | 1,004 07 |
| 25,6 | 1,003 91 | 1,003 94 | 1,003 97 | 1,004 00 | 1,004 03 | 1,004 06 | 1,004 09 | 1,004 12 |
| 25,8 | 1,003 96 | 1,003 99 | 1,004 02 | 1,004 05 | 1,004 08 | 1,004 11 | 1,004 14 | 1,004 17 |
| 26,0 | 1,004 00 | 1,004 04 | 1,004 07 | 1,004 10 | 1,004 13 | 1,004 16 | 1,004 19 | 1,004 22 |
| 26,2 | 1,004 05 | 1,004 09 | 1,004 12 | 1,004 15 | 1,004 18 | 1,004 21 | 1,004 24 | 1,004 27 |
| 26,4 | 1,004 11 | 1,004 14 | 1,004 17 | 1,004 20 | 1,004 23 | 1,004 26 | 1,004 29 | 1,004 32 |
| 26,6 | 1,004 16 | 1,004 19 | 1,004 22 | 1,004 25 | 1,004 28 | 1,004 31 | 1,004 34 | 1,004 37 |
| 26,8 | 1,004 21 | 1,004 24 | 1,004 27 | 1,004 30 | 1,004 33 | 1,004 36 | 1,004 39 | 1,004 42 |
| 27,0 | 1,004 26 | 1,004 29 | 1,004 32 | 1,004 35 | 1,004 38 | 1,004 41 | 1,004 44 | 1,004 47 |
| 27,2 | 1,004 31 | 1,004 34 | 1,004 37 | 1,004 40 | 1,004 43 | 1,004 47 | 1,004 50 | 1,004 53 |
| 27,4 | 1,004 36 | 1,004 39 | 1,004 43 | 1,004 46 | 1,004 49 | 1,004 52 | 1,004 55 | 1,004 58 |
| 27,6 | 1,004 42 | 1,004 45 | 1,004 48 | 1,004 51 | 1,004 54 | 1,004 57 | 1,004 60 | 1,004 63 |
| 27,8 | 1,004 47 | 1,004 50 | 1,004 53 | 1,004 56 | 1,004 59 | 1,004 62 | 1,004 65 | 1,004 68 |
| 28,0 | 1,004 52 | 1,004 55 | 1,004 58 | 1,004 62 | 1,004 65 | 1,004 68 | 1,004 71 | 1,004 74 |
| 28,2 | 1,004 58 | 1,004 61 | 1,004 64 | 1,004 67 | 1,004 70 | 1,004 73 | 1,004 76 | 1,004 79 |
| 28,4 | 1,004 63 | 1,004 66 | 1,004 69 | 1,004 72 | 1,004 75 | 1,004 78 | 1,004 82 | 1,004 85 |
| 28,6 | 1,004 69 | 1,004 72 | 1,004 75 | 1,004 78 | 1,004 81 | 1,004 84 | 1,004 87 | 1,004 90 |
| 28,8 | 1,004 74 | 1,004 77 | 1,004 80 | 1,004 83 | 1,004 86 | 1,004 89 | 1,004 92 | 1,004 96 |
| 29,0 | 1,004 80 | 1,004 83 | 1,004 86 | 1,004 89 | 1,004 92 | 1,004 95 | 1,004 98 | 1,005 01 |
| 29,2 | 1,004 85 | 1,004 88 | 1,004 91 | 1,004 94 | 1,004 97 | 1,005 01 | 1,005 04 | 1,005 07 |
| 29,4 | 1,004 91 | 1,004 94 | 1,004 97 | 1,005 00 | 1,005 03 | 1,005 06 | 1,005 09 | 1,005 12 |
| 29,6 | 1,004 96 | 1,005 00 | 1,005 03 | 1,005 06 | 1,005 09 | 1,005 12 | 1,005 15 | 1,005 18 |
| 29,8 | 1,005 02 | 1,005 05 | 1,005 08 | 1,005 11 | 1,005 14 | 1,005 17 | 1,005 20 | 1,005 24 |
| 30,0 | 1,005 08 | 1,005 11 | 1,005 14 | 1,005 17 | 1,005 20 | 1,005 23 | 1,005 26 | 1,005 29 |

Table B.8 — Factor Z for soda-lime glass

Z values in microlitres per milligram

| Temperature °C | Air pressure | | | | | | | |
|-------------------|--------------|----------|----------|----------|----------|----------|----------|----------|
| | hPa | | | | | | | |
| | 850 | 880 | 910 | 940 | 970 | 1 000 | 1 030 | 1 060 |
| 15,0 | 1,001 94 | 1,001 97 | 1,002 00 | 1,002 03 | 1,002 06 | 1,002 10 | 1,002 13 | 1,002 16 |
| 15,2 | 1,001 96 | 1,001 99 | 1,002 02 | 1,002 06 | 1,002 09 | 1,002 12 | 1,002 15 | 1,002 18 |
| 15,4 | 1,001 99 | 1,002 02 | 1,002 05 | 1,002 08 | 1,002 11 | 1,002 14 | 1,002 18 | 1,002 21 |
| 15,6 | 1,002 01 | 1,002 04 | 1,002 07 | 1,002 11 | 1,002 14 | 1,002 17 | 1,002 20 | 1,002 23 |
| 15,8 | 1,002 04 | 1,002 07 | 1,002 10 | 1,002 13 | 1,002 16 | 1,002 20 | 1,002 23 | 1,002 26 |
| 16,0 | 1,002 06 | 1,002 09 | 1,002 13 | 1,002 16 | 1,002 19 | 1,002 22 | 1,002 25 | 1,002 29 |
| 16,2 | 1,002 09 | 1,002 12 | 1,002 15 | 1,002 18 | 1,002 22 | 1,002 25 | 1,002 28 | 1,002 31 |
| 16,4 | 1,002 12 | 1,002 15 | 1,002 18 | 1,002 21 | 1,002 24 | 1,002 28 | 1,002 31 | 1,002 34 |
| 16,6 | 1,002 14 | 1,002 18 | 1,002 21 | 1,002 24 | 1,002 27 | 1,002 30 | 1,002 33 | 1,002 37 |
| 16,8 | 1,002 17 | 1,002 20 | 1,002 24 | 1,002 27 | 1,002 30 | 1,002 33 | 1,002 36 | 1,002 39 |
| 17,0 | 1,002 20 | 1,002 23 | 1,002 26 | 1,002 30 | 1,002 33 | 1,002 36 | 1,002 39 | 1,002 42 |
| 17,2 | 1,002 23 | 1,002 26 | 1,002 29 | 1,002 33 | 1,002 36 | 1,002 39 | 1,002 42 | 1,002 45 |
| 17,4 | 1,002 26 | 1,002 29 | 1,002 32 | 1,002 35 | 1,002 39 | 1,002 42 | 1,002 45 | 1,002 48 |
| 17,6 | 1,002 29 | 1,002 32 | 1,002 35 | 1,002 38 | 1,002 42 | 1,002 45 | 1,002 48 | 1,002 51 |
| 17,8 | 1,002 32 | 1,002 35 | 1,002 38 | 1,002 41 | 1,002 45 | 1,002 48 | 1,002 51 | 1,002 54 |
| 18,0 | 1,002 35 | 1,002 38 | 1,002 41 | 1,002 45 | 1,002 48 | 1,002 51 | 1,002 54 | 1,002 57 |
| 18,2 | 1,002 38 | 1,002 41 | 1,002 45 | 1,002 48 | 1,002 51 | 1,002 54 | 1,002 57 | 1,002 60 |
| 18,4 | 1,002 41 | 1,002 45 | 1,002 48 | 1,002 51 | 1,002 54 | 1,002 57 | 1,002 60 | 1,002 63 |
| 18,6 | 1,002 45 | 1,002 48 | 1,002 51 | 1,002 54 | 1,002 57 | 1,002 60 | 1,002 64 | 1,002 67 |
| 18,8 | 1,002 48 | 1,002 51 | 1,002 54 | 1,002 57 | 1,002 61 | 1,002 64 | 1,002 67 | 1,002 70 |
| 19,0 | 1,002 51 | 1,002 54 | 1,002 58 | 1,002 61 | 1,002 64 | 1,002 67 | 1,002 70 | 1,002 73 |
| 19,2 | 1,002 55 | 1,002 58 | 1,002 61 | 1,002 64 | 1,002 67 | 1,002 70 | 1,002 73 | 1,002 77 |
| 19,4 | 1,002 58 | 1,002 61 | 1,002 64 | 1,002 67 | 1,002 71 | 1,002 74 | 1,002 77 | 1,002 80 |
| 19,6 | 1,002 61 | 1,002 65 | 1,002 68 | 1,002 71 | 1,002 74 | 1,002 77 | 1,002 80 | 1,002 83 |
| 19,8 | 1,002 65 | 1,002 68 | 1,002 71 | 1,002 74 | 1,002 77 | 1,002 81 | 1,002 84 | 1,002 87 |
| 20,0 | 1,002 68 | 1,002 72 | 1,002 75 | 1,002 78 | 1,002 81 | 1,002 84 | 1,002 87 | 1,002 90 |
| 20,2 | 1,002 72 | 1,002 75 | 1,002 78 | 1,002 81 | 1,002 85 | 1,002 88 | 1,002 91 | 1,002 94 |
| 20,4 | 1,002 76 | 1,002 79 | 1,002 82 | 1,002 85 | 1,002 88 | 1,002 91 | 1,002 94 | 1,002 98 |
| 20,6 | 1,002 79 | 1,002 82 | 1,002 85 | 1,002 89 | 1,002 92 | 1,002 95 | 1,002 98 | 1,003 01 |
| 20,8 | 1,002 83 | 1,002 86 | 1,002 89 | 1,002 92 | 1,002 95 | 1,002 99 | 1,003 02 | 1,003 05 |
| 21,0 | 1,002 87 | 1,002 90 | 1,002 93 | 1,002 96 | 1,002 99 | 1,003 02 | 1,003 05 | 1,003 09 |
| 21,2 | 1,002 90 | 1,002 94 | 1,002 97 | 1,003 00 | 1,003 03 | 1,003 06 | 1,003 09 | 1,003 12 |
| 21,4 | 1,002 94 | 1,002 97 | 1,003 01 | 1,003 04 | 1,003 07 | 1,003 10 | 1,003 13 | 1,003 16 |
| 21,6 | 1,002 98 | 1,003 01 | 1,003 04 | 1,003 07 | 1,003 11 | 1,003 14 | 1,003 17 | 1,003 20 |
| 21,8 | 1,003 02 | 1,003 05 | 1,003 08 | 1,003 11 | 1,003 15 | 1,003 18 | 1,003 21 | 1,003 24 |
| 22,0 | 1,003 06 | 1,003 09 | 1,003 12 | 1,003 15 | 1,003 18 | 1,003 22 | 1,003 25 | 1,003 28 |
| 22,2 | 1,003 10 | 1,003 13 | 1,003 16 | 1,003 19 | 1,003 22 | 1,003 26 | 1,003 29 | 1,003 32 |
| 22,4 | 1,003 14 | 1,003 17 | 1,003 20 | 1,003 23 | 1,003 26 | 1,003 30 | 1,003 33 | 1,003 36 |

Table B.8 (continued)

Z values in microlitres per milligram

| Temperature °C | Air pressure hPa | | | | | | | |
|-------------------|---------------------|----------|----------|----------|----------|----------|----------|----------|
| | 850 | 880 | 910 | 940 | 970 | 1 000 | 1 030 | 1 060 |
| 22,6 | 1,003 18 | 1,003 21 | 1,003 24 | 1,003 27 | 1,003 30 | 1,003 34 | 1,003 37 | 1,003 40 |
| 22,8 | 1,003 22 | 1,003 25 | 1,003 28 | 1,003 31 | 1,003 35 | 1,003 38 | 1,003 41 | 1,003 44 |
| 23,0 | 1,003 26 | 1,003 29 | 1,003 33 | 1,003 36 | 1,003 39 | 1,003 42 | 1,003 45 | 1,003 48 |
| 23,2 | 1,003 30 | 1,003 34 | 1,003 37 | 1,003 40 | 1,003 43 | 1,003 46 | 1,003 49 | 1,003 52 |
| 23,4 | 1,003 35 | 1,003 38 | 1,003 41 | 1,003 44 | 1,003 47 | 1,003 50 | 1,003 53 | 1,003 56 |
| 23,6 | 1,003 39 | 1,003 42 | 1,003 45 | 1,003 48 | 1,003 51 | 1,003 55 | 1,003 58 | 1,003 61 |
| 23,8 | 1,003 43 | 1,003 46 | 1,003 49 | 1,003 53 | 1,003 56 | 1,003 59 | 1,003 62 | 1,003 65 |
| 24,0 | 1,003 48 | 1,003 51 | 1,003 54 | 1,003 57 | 1,003 60 | 1,003 63 | 1,003 66 | 1,003 69 |
| 24,2 | 1,003 52 | 1,003 55 | 1,003 58 | 1,003 61 | 1,003 64 | 1,003 68 | 1,003 71 | 1,003 74 |
| 24,4 | 1,003 56 | 1,003 60 | 1,003 63 | 1,003 66 | 1,003 69 | 1,003 72 | 1,003 75 | 1,003 78 |
| 24,6 | 1,003 61 | 1,003 64 | 1,003 67 | 1,003 70 | 1,003 73 | 1,003 76 | 1,003 79 | 1,003 83 |
| 24,8 | 1,003 65 | 1,003 69 | 1,003 72 | 1,003 75 | 1,003 78 | 1,003 81 | 1,003 84 | 1,003 87 |
| 25,0 | 1,003 70 | 1,003 73 | 1,003 76 | 1,003 79 | 1,003 82 | 1,003 85 | 1,003 89 | 1,003 92 |
| 25,2 | 1,003 75 | 1,003 78 | 1,003 81 | 1,003 84 | 1,003 87 | 1,003 90 | 1,003 93 | 1,003 96 |
| 25,4 | 1,003 79 | 1,003 82 | 1,003 85 | 1,003 88 | 1,003 92 | 1,003 95 | 1,003 98 | 1,004 01 |
| 25,6 | 1,003 84 | 1,003 87 | 1,003 90 | 1,003 93 | 1,003 96 | 1,003 99 | 1,004 02 | 1,004 05 |
| 25,8 | 1,003 89 | 1,003 92 | 1,003 95 | 1,003 98 | 1,004 01 | 1,004 04 | 1,004 07 | 1,004 10 |
| 26,0 | 1,003 93 | 1,003 96 | 1,003 99 | 1,004 03 | 1,004 06 | 1,004 09 | 1,004 12 | 1,004 15 |
| 26,2 | 1,003 98 | 1,004 01 | 1,004 04 | 1,004 07 | 1,004 10 | 1,004 13 | 1,004 17 | 1,004 20 |
| 26,4 | 1,004 03 | 1,004 06 | 1,004 09 | 1,004 12 | 1,004 15 | 1,004 18 | 1,004 21 | 1,004 24 |
| 26,6 | 1,004 08 | 1,004 11 | 1,004 14 | 1,004 17 | 1,004 20 | 1,004 23 | 1,004 26 | 1,004 29 |
| 26,8 | 1,004 13 | 1,004 16 | 1,004 19 | 1,004 22 | 1,004 25 | 1,004 28 | 1,004 31 | 1,004 34 |
| 27,0 | 1,004 18 | 1,004 21 | 1,004 24 | 1,004 27 | 1,004 30 | 1,004 33 | 1,004 36 | 1,004 39 |
| 27,2 | 1,004 22 | 1,004 26 | 1,004 29 | 1,004 32 | 1,004 35 | 1,004 38 | 1,004 41 | 1,004 44 |
| 27,4 | 1,004 27 | 1,004 31 | 1,004 34 | 1,004 37 | 1,004 40 | 1,004 43 | 1,004 46 | 1,004 49 |
| 27,6 | 1,004 33 | 1,004 36 | 1,004 39 | 1,004 42 | 1,004 45 | 1,004 48 | 1,004 51 | 1,004 54 |
| 27,8 | 1,004 38 | 1,004 41 | 1,004 44 | 1,004 47 | 1,004 50 | 1,004 53 | 1,004 56 | 1,004 59 |
| 28,0 | 1,004 43 | 1,004 46 | 1,004 49 | 1,004 52 | 1,004 55 | 1,004 58 | 1,004 61 | 1,004 64 |
| 28,2 | 1,004 48 | 1,004 51 | 1,004 54 | 1,004 57 | 1,004 60 | 1,004 63 | 1,004 66 | 1,004 69 |
| 28,4 | 1,004 53 | 1,004 56 | 1,004 59 | 1,004 62 | 1,004 65 | 1,004 68 | 1,004 71 | 1,004 74 |
| 28,6 | 1,004 58 | 1,004 61 | 1,004 64 | 1,004 67 | 1,004 71 | 1,004 74 | 1,004 77 | 1,004 80 |
| 28,8 | 1,004 64 | 1,004 67 | 1,004 70 | 1,004 73 | 1,004 76 | 1,004 79 | 1,004 82 | 1,004 85 |
| 29,0 | 1,004 69 | 1,004 72 | 1,004 75 | 1,004 78 | 1,004 81 | 1,004 84 | 1,004 87 | 1,004 90 |
| 29,2 | 1,004 74 | 1,004 77 | 1,004 80 | 1,004 83 | 1,004 86 | 1,004 89 | 1,004 92 | 1,004 96 |
| 29,4 | 1,004 80 | 1,004 83 | 1,004 86 | 1,004 89 | 1,004 92 | 1,004 95 | 1,004 98 | 1,005 01 |
| 29,6 | 1,004 85 | 1,004 88 | 1,004 91 | 1,004 94 | 1,004 97 | 1,005 00 | 1,005 03 | 1,005 06 |
| 29,8 | 1,004 90 | 1,004 93 | 1,004 96 | 1,005 00 | 1,005 03 | 1,005 06 | 1,005 09 | 1,005 12 |
| 30,0 | 1,004 96 | 1,004 99 | 1,005 02 | 1,005 05 | 1,005 08 | 1,005 11 | 1,005 14 | 1,005 17 |

Bibliography

- [1] ISO 384, *Laboratory glassware — Principles of design and construction of volumetric glassware*
- [2] ISO 3507, *Laboratory glassware — Pyknometers*
- [3] ISO 4797, *Laboratory glassware — Boiling flasks with conical ground joints*
- [4] OIML D 28, *Conventional value of the result of weighing in air (Revision of R 33)*
- [5] TANAKA, M., GIRARD, G., DAVIS, R., PEUTO, A. and BIGNELL, N. Recommended table for the density of water between 0 °C and 40 °C based on recent experimental reports. *Metrologia*, **38**, 2001, pp. 301-309

This page is intentionally blank.

This page is intentionally blank.

17.060

Price based on 21 pages