

INTERNATIONAL STANDARD

ISO 4753

Second edition
1999-12-01

Fasteners — Ends of parts with external ISO metric thread

*Éléments de fixation — Extrémités des éléments à filetage extérieur
métrique ISO*

This material is reproduced from ISO documents under International Organization for Standardization (ISO) Copyright License Number HIS/CC/1996. Not for resale. No part of these ISO documents may be reproduced in any form, electronic retrieval system or otherwise, except as allowed in the copyright law of the country of use, or with the prior written consent of ISO (Case postale 56, 1211 Geneva 20, Switzerland Fax +41 22 734 10 79), IHS or the ISO Licensor's members.



Reference number
ISO 4753:1999(E)

ISO 4753:1999(E)**Foreword**

ISO (the International Organization for Standardization) is a worldwide federation of national standards bodies (ISO member bodies). The work of preparing International Standards is normally carried out through ISO technical committees. Each member body interested in a subject for which a technical committee has been established has the right to be represented on that committee. International organizations, governmental and non-governmental, in liaison with ISO, also take part in the work. ISO collaborates closely with the International Electrotechnical Commission (IEC) on all matters of electrotechnical standardization.

International Standards are drafted in accordance with the rules given in the ISO/IEC Directives, Part 3.

Draft International Standards adopted by the technical committees are circulated to the member bodies for voting. Publication as an International Standard requires approval by at least 75 % of the member bodies casting a vote.

International Standard ISO 4753 was prepared by Technical Committee ISO/TC 2, *Fasteners*, Subcommittee SC 7, *Reference Standards for fasteners (mainly covering terminology, dimensioning, sizes and tolerancing)*.

This second edition cancels and replaces the first edition (ISO 4753:1983) which has been technically revised.

© ISO 1999

All rights reserved. Unless otherwise specified, no part of this publication may be reproduced or utilized in any form or by any means, electronic or mechanical, including photocopying and microfilm, without permission in writing from the publisher.

International Organization for Standardization
Case postale 56 • CH-1211 Genève 20 • Switzerland
Internet iso@iso.ch

Printed in Switzerland

Fasteners — Ends of parts with external ISO metric thread

1 Scope

This International Standard specifies the form and dimensions of ends of parts with external ISO metric screw thread (e.g., bolt and screw ends) recommended for use. They apply to standardized or non-standardized threaded parts if they are specified at the time of order.

For each end type a symbol is specified and it is recommended to use these symbols when specifying one of the ends for threaded fasteners.

2 Normative references

The following normative documents contain provisions which, through reference in this text, constitute provisions of this International Standard. For dated references, subsequent amendments to, or revisions of, any of these publications do not apply. However, parties to agreements based on this International Standard are encouraged to investigate the possibility of applying the most recent editions of the normative documents indicated below. For undated references, the latest edition of the normative document referred to applies. Members of ISO and IEC maintain registers of currently valid International Standards.

ISO 225:1983, *Fasteners — Bolts, screws, studs and nuts — Symbols and designations of dimensions.*

ISO 4027:1993, *Hexagon socket set screws with cone point.*

3 Dimensions

See Figures 1 and 2 and Tables 1 to 4.

Symbols and designations of dimensions are specified in ISO 225.

3.1 Ends which are included in the nominal length of the fastener

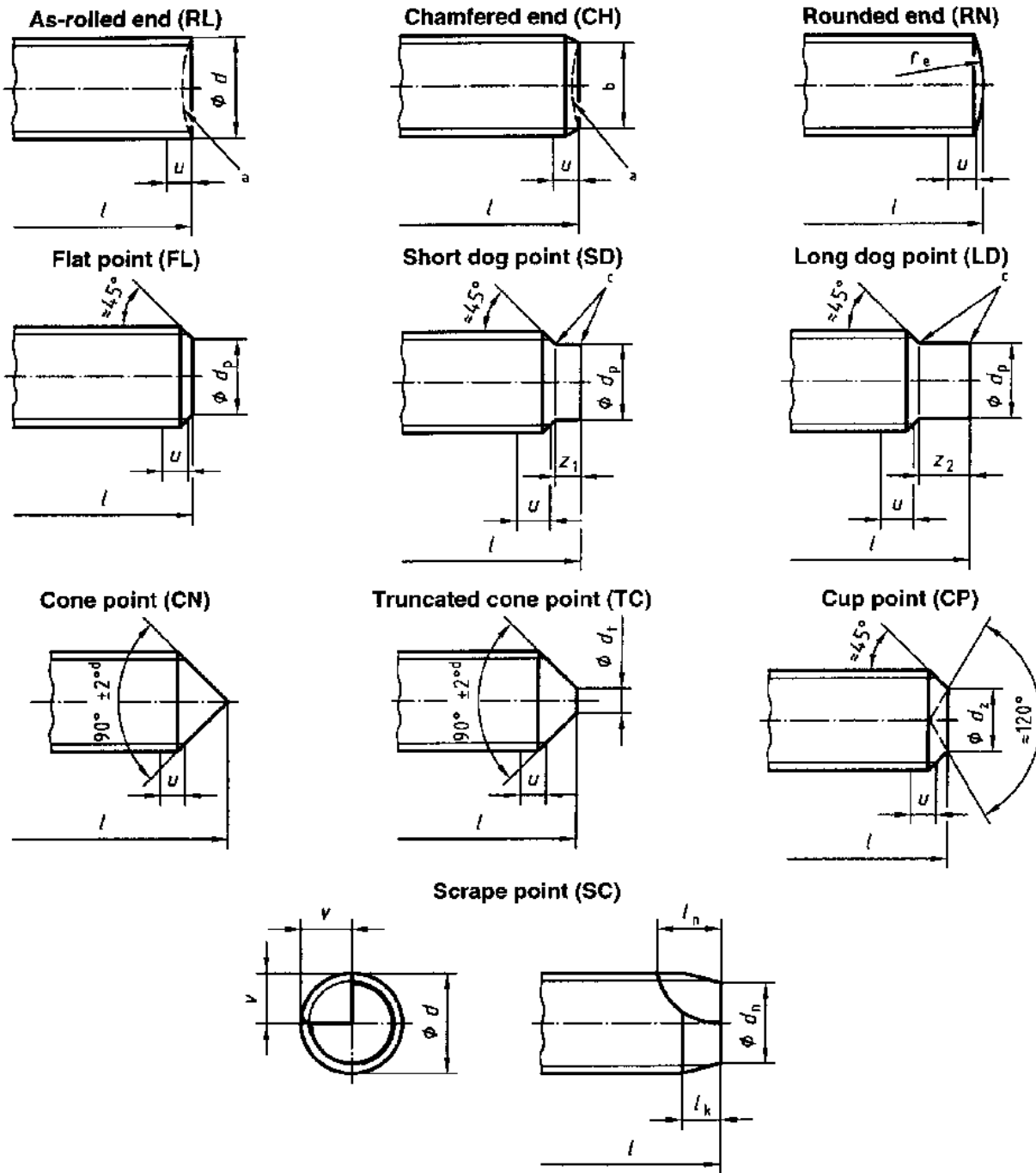

$r_e \approx 1,4d$ $v = 0,5d \pm 0,5 \text{ mm}$ $l_n \leq 5P$
 $d_n = d - 1,6P$ $l_k \leq 3P$ $l_n - l_k \geq 2P$ (P is the pitch of thread)

NOTE 1 l is the nominal length of the fastener.

NOTE 2 Incomplete thread $u \leq 2P$

NOTE 3 The 45° angle for the ends FL, SD, LD and CP applies only to the portion of the point below the root diameter of the thread.

a End may be dimpled.

c Slight radius

b Maximum diameter at the minor thread diameter.

d $120^\circ \pm 2^\circ$ for short length screws; see product standard, e.g. ISO 4027.

Figure 1

Table 1 — Dimensions

Dimensions in millimetres

| Thread diameter d^a | d_p h14 ^b | d_1^c h16 | d_2 h14 | z_1 $+IT_{14}^d$ 0 | z_2 $+IT_{14}^d$ 0 |
|--------------------------|---------------------------|----------------|--------------|----------------------------|----------------------------|
| 1,6 | 0,8 | — | 0,8 | 0,4 | 0,8 |
| 1,8 | 0,9 | — | 0,9 | 0,45 | 0,9 |
| 2 | 1 | — | 1 | 0,5 | 1 |
| 2,2 | 1,2 | — | 1,1 | 0,55 | 1,1 |
| 2,5 | 1,5 | — | 1,2 | 0,63 | 1,25 |
| 3 | 2 | — | 1,4 | 0,75 | 1,5 |
| 3,5 | 2,2 | — | 1,7 | 0,88 | 1,75 |
| 4 | 2,5 | — | 2 | 1 | 2 |
| 4,5 | 3 | — | 2,2 | 1,12 | 2,25 |
| 5 | 3,5 | — | 2,5 | 1,25 | 2,5 |
| 6 | 4 | 1,5 | 3 | 1,5 | 3 |
| 7 | 5 | 2 | 4 | 1,75 | 3,5 |
| 8 | 5,5 | 2 | 5 | 2 | 4 |
| 10 | 7 | 2,5 | 6 | 2,5 | 5 |
| 12 | 8,5 | 3 | 8 | 3 | 6 |
| 14 | 10 | 4 | 8,5 | 3,5 | 7 |
| 16 | 12 | 4 | 10 | 4 | 8 |
| 18 | 13 | 5 | 11 | 4,5 | 9 |
| 20 | 15 | 5 | 14 | 5 | 10 |
| 22 | 17 | 6 | 15 | 5,5 | 11 |
| 24 | 18 | 6 | 16 | 6 | 12 |
| 27 | 21 | 8 | — | 6,7 | 13,5 |
| 30 | 23 | 8 | — | 7,5 | 15 |
| 33 | 26 | 10 | — | 8,2 | 16,5 |
| 36 | 28 | 10 | — | 9 | 18 |
| 39 | 30 | 12 | — | 9,7 | 19,5 |
| 42 | 32 | 12 | — | 10,5 | 21 |
| 45 | 35 | 14 | — | 11,2 | 22,5 |
| 48 | 38 | 14 | — | 12 | 24 |
| 52 | 42 | 16 | — | 13 | 26 |

^a For sizes < M1,6 dimensions and tolerances should be agreed as suitable.

^b For nominal dimensions ≤ 1 mm tolerance field h13 applies.

^c For threads \leq M5 no flat part on the cone required; the point may be slightly rounded.

^d For nominal dimensions ≤ 1 mm tolerance field $+IT_{13}^d$ applies.

3.2 Ends which are added to the specified nominal length of the fastener

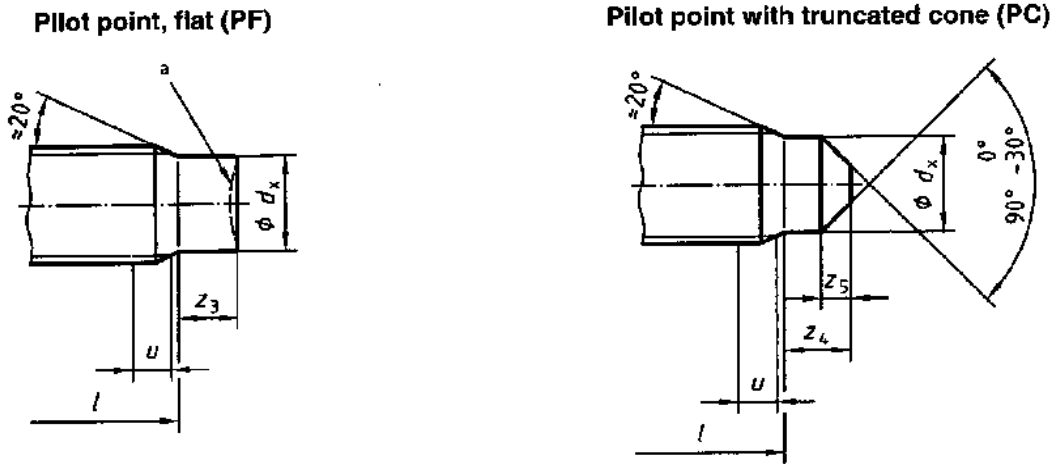

NOTE 1 Incomplete thread $u \leq 2P$

NOTE 2 The 20° angle applies only to the portion of the point below the root diameter of the thread.

^a End may be dimpled.

Figure 2

Table 2 — Dimensions for flat pilot points; coarse pitch thread

Dimensions in millimetres

| Thread size | M4 | M5 | M6 | M8 | M10 | M12 | M14 | M16 | M20 | M24 | |
|--|------|-----|-----|-----|-----|-----|-----|------|------|------|------|
| d_x^a | max. | 2,9 | 3,8 | 4,5 | 6,1 | 7,8 | 9,4 | 11,1 | 13,1 | 16,3 | 19,6 |
| | min. | 2,7 | 3,6 | 4,3 | 5,9 | 7,6 | 9,1 | 10,8 | 12,8 | 15,9 | 19,2 |
| $z_3 \begin{smallmatrix} +IT17 \\ 0 \end{smallmatrix}$ | 2 | 2,5 | 3 | 4 | 5 | 6 | 7 | 8 | 10 | 12 | |

^a If, in special cases, a smaller diameter is required this must be agreed separately.

Table 3 — Dimensions for pilot points with truncated cone; coarse pitch thread

Dimensions in millimetres

| Thread size | M4 | M5 | M6 | M8 | M10 | M12 | M14 | M16 | M20 | M24 | |
|--|------|-----|------|-----|-----|-----|-----|------|------|------|------|
| d_x^a | max. | 2,9 | 3,8 | 4,5 | 6,1 | 7,8 | 9,4 | 11,1 | 13,1 | 16,3 | 19,6 |
| | min. | 2,7 | 3,6 | 4,3 | 5,9 | 7,6 | 9,1 | 10,8 | 12,8 | 15,9 | 19,2 |
| $z_4 \begin{smallmatrix} +IT17 \\ 0 \end{smallmatrix}$ | 2 | 2,5 | 3 | 4 | 5 | 6 | 7 | 8 | 10 | 12 | |
| z_5 | max. | 1,0 | 1,50 | 2 | 2,5 | 3,0 | 3,5 | 4 | 4,5 | 5 | 6 |
| | min. | 0,5 | 0,75 | 1 | 1,5 | 1,5 | 2,0 | 2 | 2,5 | 3 | 4 |

^a If in special cases a smaller diameter is required this must be agreed separately.

Table 4 — Dimensions for pilot points with truncated cone; fine pitch thread

Dimensions in millimetres

| Thread size | | M8 × 1 | M10 × 1 | M12 × 1,5 | M14 × 1,5 | M16 × 1,5 |
|-------------|---|--------|---------|-----------|-----------|-----------|
| d_x | max. | 6,3 | 8,0 | 9,6 | 11,40 | 13,50 |
| | min. | 6,08 | 7,78 | 9,38 | 11,13 | 13,23 |
| z_4 | $\begin{matrix} +IT_{17} \\ 0 \end{matrix}$ | 4 | 5 | 6 | 7 | 8 |
| z_5 | max. | 2,5 | 3 | 3,5 | 4 | 4,5 |
| | min. | 1,5 | 1,5 | 2 | 2 | 2,5 |

ICS 21.060.01

Price based on 5 pages
