**Iron ores for blast furnace feedstocks —
Determination of low-temperature
reduction-disintegration indices by static
method —**

Part 2:
Reduction with CO and N₂

*Minerais de fer pour charges de hauts fourneaux — Détermination des
indices de désagrégation par réduction à basse température par
méthode statique —*

Partie 2: Réduction avec CO et N₂



Reference number
ISO 4696-2:2007(E)

© ISO 2007

PDF disclaimer

This PDF file may contain embedded typefaces. In accordance with Adobe's licensing policy, this file may be printed or viewed but shall not be edited unless the typefaces which are embedded are licensed to and installed on the computer performing the editing. In downloading this file, parties accept therein the responsibility of not infringing Adobe's licensing policy. The ISO Central Secretariat accepts no liability in this area.

Adobe is a trademark of Adobe Systems Incorporated.

Details of the software products used to create this PDF file can be found in the General Info relative to the file; the PDF-creation parameters were optimized for printing. Every care has been taken to ensure that the file is suitable for use by ISO member bodies. In the unlikely event that a problem relating to it is found, please inform the Central Secretariat at the address given below.



COPYRIGHT PROTECTED DOCUMENT

© ISO 2007

All rights reserved. Unless otherwise specified, no part of this publication may be reproduced or utilized in any form or by any means, electronic or mechanical, including photocopying and microfilm, without permission in writing from either ISO at the address below or ISO's member body in the country of the requester.

ISO copyright office
Case postale 56 • CH-1211 Geneva 20
Tel. + 41 22 749 01 11
Fax + 41 22 749 09 47
E-mail copyright@iso.org
Web www.iso.org

Published in Switzerland

Contents

Page

| | |
|--|-----------|
| Foreword | iv |
| Introduction | v |
| 1 Scope | 1 |
| 2 Normative references | 1 |
| 3 Terms and definitions | 1 |
| 4 Principle | 2 |
| 5 Sampling, sample preparation and preparation of test portions | 2 |
| 6 Apparatus | 2 |
| 7 Test conditions | 3 |
| 8 Procedure | 4 |
| 9 Expression of results | 5 |
| 10 Test report | 6 |
| 11 Verification | 6 |
| Annex A (normative) Flowsheet of the procedure for the acceptance of test results | 10 |

Foreword

ISO (the International Organization for Standardization) is a worldwide federation of national standards bodies (ISO member bodies). The work of preparing International Standards is normally carried out through ISO technical committees. Each member body interested in a subject for which a technical committee has been established has the right to be represented on that committee. International organizations, governmental and non-governmental, in liaison with ISO, also take part in the work. ISO collaborates closely with the International Electrotechnical Commission (IEC) on all matters of electrotechnical standardization.

International Standards are drafted in accordance with the rules given in the ISO/IEC Directives, Part 2.

The main task of technical committees is to prepare International Standards. Draft International Standards adopted by the technical committees are circulated to the member bodies for voting. Publication as an International Standard requires approval by at least 75 % of the member bodies casting a vote.

Attention is drawn to the possibility that some of the elements of this document may be the subject of patent rights. ISO shall not be held responsible for identifying any or all such patent rights.

ISO 4696-2 was prepared by Technical Committee ISO/TC 102, *Iron ore and direct reduced iron*, Subcommittee SC 3, *Physical testing*.

This second edition cancels and replaces the first edition (ISO 4696-2:1998), which has been revised to homogenise with other physical test standards.

ISO 4696 consists of the following parts, under the general title *Iron ores for blast furnace feedstocks — Determination of low-temperature reduction-disintegration indices by static method*:

- *Part 1: Reduction with CO, CO₂, H₂ and N₂*
- *Part 2: Reduction with CO and N₂*

Introduction

This part of ISO 4696 concerns one of a number of physical test methods that have been developed to measure various physical parameters and to evaluate the behaviour of iron ores, including reducibility, disintegration, crushing strength, apparent density, etc. This method was developed to provide a uniform procedure, validated by collaborative testing, to facilitate comparisons of tests made in different laboratories.

The results of this test should be considered in conjunction with other tests used to evaluate the quality of iron ores as feedstocks for blast furnace processes.

This part of ISO 4696 may be used to provide test results as part of a production quality control system, as a basis of a contract, or as part of a research project.

Iron ores for blast furnace feedstocks — Determination of low-temperature reduction-disintegration indices by static method —

Part 2: Reduction with CO and N₂

CAUTION — This standard may involve hazardous materials, operations and equipment. This standard does not purport to address all of the safety issues associated with its use. It is the responsibility of the user of this part of ISO 4696 to establish appropriate safety and health practices and determine the applicability of regulatory limitations prior to its use.

1 Scope

This part of ISO 4696 specifies a method to provide a relative measure for evaluating the degree of size degradation of iron ores when reduced with carbon monoxide and nitrogen, under conditions resembling those prevailing in the low-temperature reduction zone of a blast furnace.

This part of ISO 4696 is applicable to lump ores, sinters and hot-bonded pellets.

2 Normative references

The following referenced documents are indispensable for the application of this document. For dated references, only the edition cited applies. For undated references, the latest edition of the referenced document (including any amendments) applies.

ISO 3082:2000¹⁾, *Iron ores — Sampling and sample preparation procedures*

ISO 3310-1:2000, *Test sieves — Technical requirements and testing — Part 1: Test sieves of metal wire cloth*

ISO 3310-2:1999, *Test sieves — Technical requirements and testing — Part 2: Test sieves of perforated metal plate*

ISO 4701:—²⁾, *Iron ores and direct reduced iron — Determination of size distribution by sieving*

ISO 11323:2002, *Iron ore and direct reduced iron — Vocabulary*

3 Terms and definitions

For the purposes of this document, the terms and definitions given in ISO 11323 apply.

1) Under revision to incorporate ISO 10836, *Iron ores — Method of sampling and sample preparation for physical testing*.

2) To be published. (Revision of ISO 4701:1999)

4 Principle

The test portion is isothermally reduced in a fixed bed, at 550 °C, using a reducing gas consisting of CO and N₂, for 30 min. The reduced test portion is tumbled in a specific tumble drum for 900 revolutions and then sieved with a sieve having square openings of 2,8 mm. The reduction-disintegration index (RDI) is calculated as the mass percentage of material –2,8 mm.

5 Sampling, sample preparation and preparation of test portions

5.1 Sampling and sample preparation

Sampling of a lot and preparation of a test sample shall be in accordance with ISO 3082.

The size range for pellets shall be – 12,5 mm + 10,0 mm.

The size range for sinters and lump ores shall be – 20,0 mm + 16,0 mm.

A test sample of at least 2 kg, on dry basis, of the sized material shall be obtained.

Oven-dry the test sample to constant mass at 105 °C ± 5 °C and cool it to room temperature before preparation of the test portions.

NOTE Constant mass is achieved when the difference in mass between two subsequent measurements becomes less than 0,05 % of the initial mass of the test sample.

5.2 Preparation of test portions

Collect each test portion by taking ore particles at random.

NOTE Manual methods of division recommended in ISO 3082, such as riffing, can be applied to obtain the test portions.

At least 4 test portions, each of approximately 500 g (± the mass of 1 particle) shall be prepared from the test sample.

Weigh the test portions to the nearest 0,1 g and register the mass of each test portion on its recipient label.

6 Apparatus

6.1 General

The test apparatus shall comprise

- a) ordinary laboratory equipment, such as an oven, hand tools, a time-control device and safety equipment;
- b) a reduction-tube assembly;
- c) a furnace;
- d) a system to supply the gases and regulate the flow rates;
- e) a tumble drum;
- f) test sieves;
- g) a weighing device.

Figure 1 shows an example of the test apparatus.

6.2 Reduction tube, made of non-scaling, heat-resistant metal to withstand temperatures higher than 600 °C, and resistant to deformation. The internal diameter shall be 75 mm \pm 1 mm. A removable perforated plate made of non-scaling, heat-resistant metal to withstand temperatures higher than 600 °C shall be mounted in the reduction tube to support the test portion and to ensure uniform gas flow through it. The perforated plates shall be 4 mm thick, with its diameter 1 mm less than the tube internal diameter. The holes in the plate shall be 2 mm to 3 mm in diameter at a pitch centre distance of 4 mm to 5 mm.

Figure 2 shows an example of a reduction tube.

6.3 Furnace, having a heating capacity and temperature control able to maintain the entire test portion as well as the gas entering the bed at 550 °C \pm 5 °C.

6.4 Gas-supply system, capable of supplying the gases and regulating gas flow rates.

6.5 Tumble drum, made of steel, at least 5 mm thick, having an internal diameter of 130 mm and an inside length of 200 mm. Two equally spaced steel lifters (200 mm long, 20 mm high and 2 mm thick) shall be mounted longitudinally inside the drum. These may be mounted on a frame that can be inserted inside the vessel from one end. One end of the drum shall be closed and the other open. A close-fitting lid shall be held in place on the opening to ensure a dust-tight seal. The drum shall be replaced in any case when the thickness of the vessel wall is reduced to 3 mm in any area, and the lifters when their height is reduced to less than 18 mm.

Figure 3 shows an example of a tumble drum.

6.6 Rotation equipment, capable of ensuring that the drum attains full speed in one revolution, rotates at a constant speed of 30 r/min \pm 1 r/min and stops within one revolution. The equipment shall be fitted with a revolution counter and with an automatic device for stopping the drum after a predetermined number of revolutions.

6.7 Test sieves, conforming to ISO 3310-1 or ISO 3310-2 and having a square aperture of 2,8 mm nominal size.

6.8 Weighing device, capable of weighing the test sample and test portions to an accuracy of 0,1 g.

7 Test conditions

7.1 General

Volumes and flow rates of gases are as measured at a reference temperature of 0 °C and at a reference atmospheric pressure of 101,325 kPa (1,013 25 bar).

7.2 Reducing gas

7.2.1 Composition

The reducing gas shall consist of:

| | |
|----------------|--------------------------------------|
| CO | 30,0 % \pm 0,5 % (volume fraction) |
| N ₂ | 70,0 % \pm 0,5 % (volume fraction) |

7.2.2 Purity

Impurities in the reducing gas shall not exceed:

| | |
|------------------|--------------------------|
| H ₂ | 0,01 % (volume fraction) |
| Total impurities | 0,1 % (volume fraction) |

7.2.3 Flow rate

The flow rate of the reducing gas, during the entire reducing period, shall be maintained at 15 L/min \pm 0,5 L/min.

7.3 Heating and cooling gas

Nitrogen (N₂) shall be used as the heating and cooling gas. Impurities shall not exceed 0,1 % (volume fraction).

The flow rate of N₂ shall be maintained at 5 L/min until the test portion reaches 550 °C and at 15 L/min during temperature-equilibration period. During cooling, it shall be maintained at 5 L/min.

7.4 Temperature of the test portion

The temperature of the entire test portion shall be maintained at 550 °C \pm 5 °C during the entire reducing period and, as such, the reducing gas shall be preheated before entering the test portion.

8 Procedure

8.1 Number of determinations for the test

Carry out the test as many times as required by the procedure in Annex A.

8.2 Reduction

Take, at random, one of the test portions prepared in 5.2. Place it in the reduction tube (6.2) and level its surface.

NOTE In order to achieve a more uniform gas flow, a double-layer bed of porcelain balls may be placed between the perforated plate and the test portion.

Close the top of the reduction tube. Connect the thermocouple, ensuring that its tip is in the centre of the test portion.

Insert the reduction tube into the furnace (6.3).

Connect the gas-supply system (6.4).

Pass a flow of N₂ through the test portion at a rate of at least 5 L/min and commence heating. When the temperature of test portion approaches 550 °C, increase the flow rate to 15 L/min. Continue heating while maintaining the flow of N₂ until the test portion reaches 550 °C \pm 10 °C. Allow a period of 15 min for temperature equilibration at 550 °C.

DANGER — Carbon monoxide and the reducing gas, which contains carbon monoxide, are toxic and therefore hazardous. Testing shall be carried out in a well ventilated area or under a hood. Precautions should be taken for the safety of the operator, in accordance with the safety codes of each country.

Introduce the reducing gas at a flow rate of 15 L/min \pm 0,5 L/min to replace the N₂. After 30 min of reduction, turn off the power. Replace the reducing gas with N₂ at a flow rate of 5 L/min and cool the test portion to a temperature below 100 °C.

8.3 Tumbling

Remove the test portion carefully from the reduction tube. Determine its mass (m_0) and place it in the tumble drum (6.5). Fasten the lid tightly and rotate the drum for a total of 900 revolutions at a rate of 30 r/min \pm 1 r/min.

8.4 Sieving

Remove all material from the drum, determine and record the mass and hand-sieve with care on 2,8 mm sieve in accordance with ISO 4701. Determine and record the mass retained on this sieve (m_1). Material lost during tumbling and sieving shall be considered to be part of the -2,8 mm fraction.

9 Expression of results

9.1 Calculation of the reduction-disintegration index (RDI-2_{-2,8})

The reduction-disintegration index, RDI-2_{-2,8}, expressed as a percentage by mass, is calculated from the following equation:

$$\text{RDI-2}_{-2,8} = 100 - \frac{m_1}{m_0} \times 100$$

where

m_0 is the mass, in grams, of the test portion after reduction and before tumbling;

m_1 is the mass, in grams, of the fraction retained on the 2,8 mm sieve.

Record the result to one decimal place.

9.2 Repeatability and acceptance of test results

Follow the procedure of Annex A by using the repeatability value given in Table 1. The results shall be reported to one decimal place.

Table 1 — Repeatability (r)

| Mean value of RDI-2 % | r %, absolute |
|--------------------------|--------------------|
| 1 | 0,45 |
| 2 | 0,88 |
| 3 | 1,29 |
| 4 | 1,68 |
| 5 | 2,05 |
| 7 | 2,73 |
| 10 | 3,60 |
| 15 | 4,66 |
| 20 | 5,21 |
| 25 | 5,30 |
| 30 | 5,30 |
| 35 | 5,30 |
| 40 | 5,30 |
| 45 | 5,30 |
| 50 | 5,30 |
| 55 | 5,30 |
| 60 | 5,30 |

10 Test report

The test report shall include the following information:

- a) reference to this part of ISO 4696, i.e. ISO 4696-2:2007;
- b) all details necessary for the identification of the sample;
- c) the name and address of the test laboratory;
- d) the date of the test;
- e) the date of the test report;
- f) the signature of the person responsible for the test;
- g) details of any operation and any test conditions not specified in this part of ISO 4696 or regarded as optional, as well as any incident which may have had an influence on the results;
- h) the reduction-disintegration index, RDI_{-2,8};
- i) the type of sieve used;
- j) the sieving conditions, e.g. the method of sieving and the sieving time;
- k) the total mass of the material inserted into the tumble drum and taken from the tumble drum.

11 Verification

Regular checking of apparatus is essential to ensure test result reliability. The frequency of checking is a matter for each laboratory to determine.

The conditions of the following items shall be checked:

- sieves;
- weighing device;
- reduction tube;
- temperature control and measurement devices;
- gas flow meters;
- purity of gases;
- time-control device;
- tumble drum;
- drum-rotation equipment.

It is recommended that internal reference material be prepared and used periodically to check test repeatability.

Appropriate records of verification activities shall be maintained.

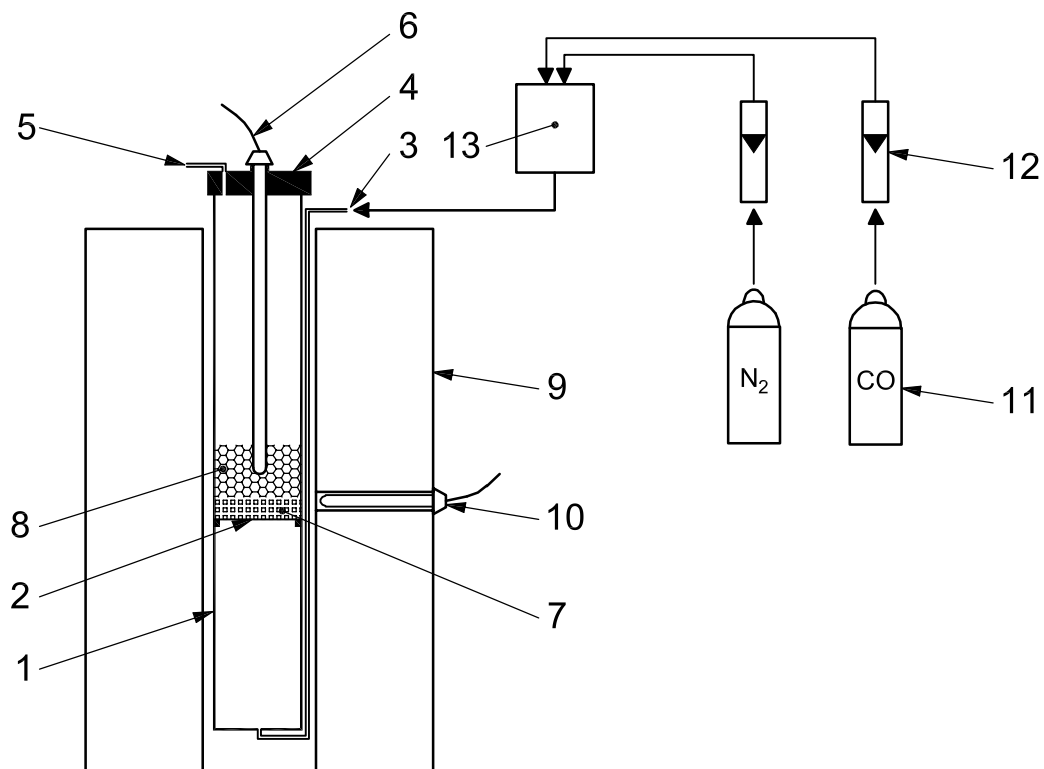
**Key****Reduction tube**

- 1 reduction-tube wall
- 2 perforated plate
- 3 gas inlet
- 4 lid
- 5 gas outlet
- 6 thermocouple for measuring the reduction temperature
- 7 porcelain ball layer
- 8 test portion

Furnace

- 9 electrically heated furnace
- 10 thermocouple for temperature regulation of furnace

Gas-supply system

- 11 gas cylinders
- 12 gas flow meters
- 13 mixing vessel

Figure 1 — Example of test apparatus (schematic diagram)

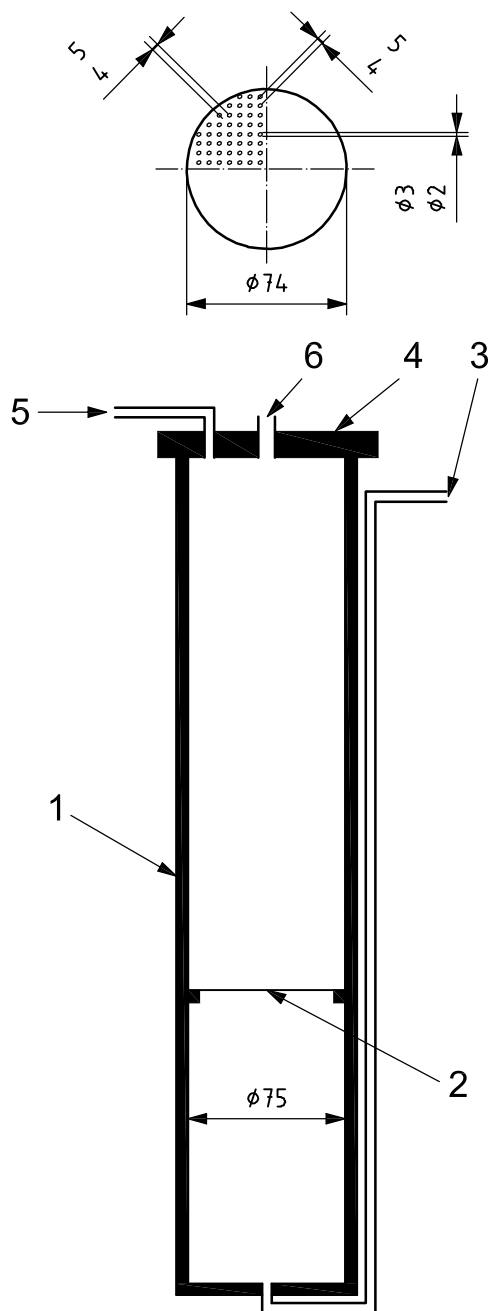

Key

- 1 reduction-tube wall
- 2 perforated plate
- 3 opening for gas inlet
- 4 lid
- 5 opening for gas outlet
- 6 opening for thermocouple insertion

NOTE The dimensions not specified in the apparatus clause are shown for information only.

Figure 2 — Example of a reduction tube (schematic diagram)

Dimensions in millimetres

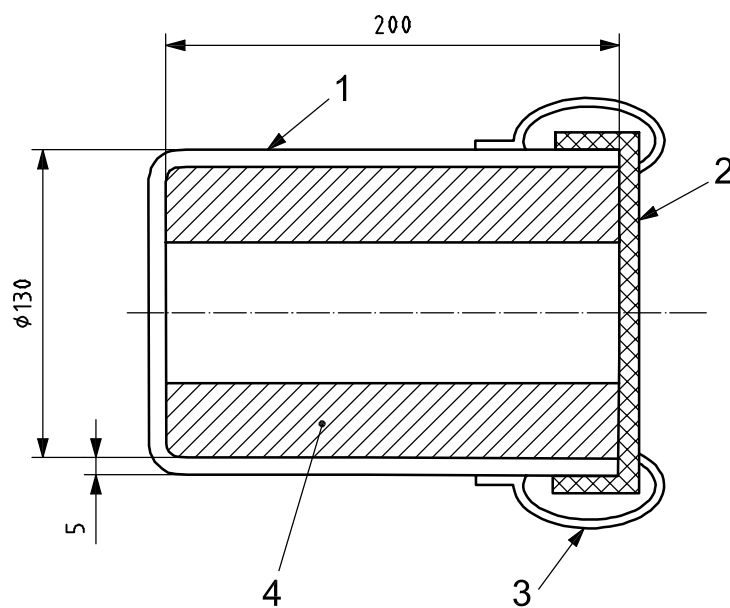
**Key**

- 1 vessel
- 2 lid
- 3 clamps
- 4 frame with lifters

Lifters: 20 mm high by 2 mm thick plain

Material: plain carbon steel

Figure 3 — Example of RDI tumble drum (schematic diagram)

Annex A (normative)

Flowsheet of the procedure for the acceptance of test results

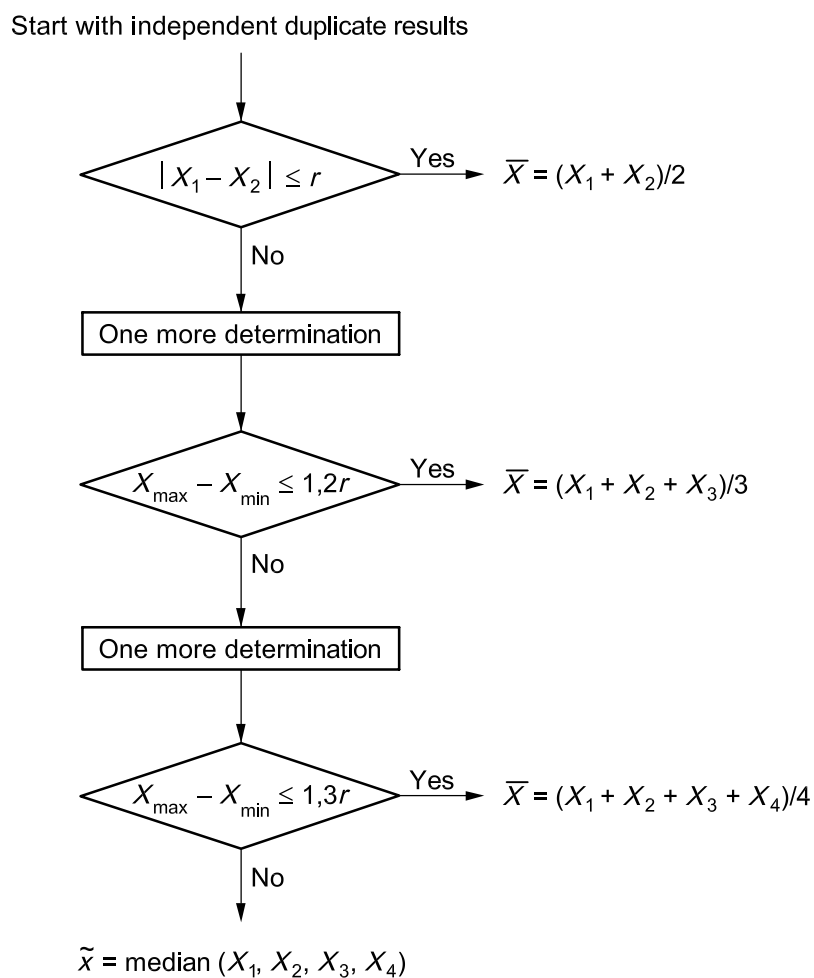

r: see Table 1

ICS 73.060.10

Price based on 10 pages