

INTERNATIONAL STANDARD

ISO
4675

Second edition
1990-07-15

Rubber- or plastics-coated fabrics — Low-temperature bend test

Supports textiles revêtus de caoutchouc ou de plastique — Essai de flexion à basse température



Reference number
ISO 4675:1990(E)

ISO 4675:1990(E)**Foreword**

ISO (the International Organization for Standardization) is a worldwide federation of national standards bodies (ISO member bodies). The work of preparing International Standards is normally carried out through ISO technical committees. Each member body interested in a subject for which a technical committee has been established has the right to be represented on that committee. International organizations, governmental and non-governmental, in liaison with ISO, also take part in the work. ISO collaborates closely with the International Electrotechnical Commission (IEC) on all matters of electrotechnical standardization.

Draft International Standards adopted by the technical committees are circulated to the member bodies for voting. Publication as an International Standard requires approval by at least 75 % of the member bodies casting a vote.

International Standard ISO 4675 was prepared by Technical Committee ISO/TC 45, *Rubber and rubber products*.

This second edition cancels and replaces the first edition (ISO 4675:1979), of which it constitutes a technical revision.

© ISO 1990

All rights reserved. No part of this publication may be reproduced or utilized in any form or by any means, electronic or mechanical, including photocopying and microfilm, without permission in writing from the publisher.

International Organization for Standardization
Case Postale 56 • CH-1211 Genève 20 • Switzerland

Printed in Switzerland

Rubber- or plastics-coated fabrics — Low-temperature bend test

1 Scope

This international Standard specifies a method for determining the ability of fabrics coated with rubber or plastics to resist the effect of low temperature when subjected to bending at specified temperatures after definite periods of exposure. It is applicable to material with a thickness within the range 0,1 mm to 2,2 mm. For materials of greater thickness than this, modifications to the standard equipment are necessary (see 8.2, third paragraph).

Because fabrics coated with rubber or plastics are used in different applications requiring low-temperature flexing, no general relationship between this test and service performance can be given or implied.

2 Normative references

The following standards contain provisions which, through reference in this text, constitute provisions of this International Standard. At the time of publication, the editions indicated were valid. All standards are subject to revision, and parties to agreements based on this International Standard are encouraged to investigate the possibility of applying the most recent editions of the standards indicated below. Members of IEC and ISO maintain registers of currently valid International Standards.

ISO 2231:1989, *Rubber- or plastics-coated fabrics — Standard atmospheres for conditioning and testing*.

ISO 2286:1986, *Rubber- or plastics-coated fabrics — Determination of roll characteristics*.

3 Principle

Conditioning of test pieces in a specified atmosphere, followed by exposure for a specified time in a cold chamber with a specified atmosphere. Sub-

jection of the test pieces to a bend test, using an appropriate apparatus, and examination of the test pieces.

4 Apparatus

4.1 Cold chamber, in which the test pieces are exposed to low temperature, sufficient in size to contain the bending fixture used for testing the test pieces and to permit the operation of the fixture to bend the test piece without removal from the chamber.

The cold chamber shall also have sufficient work space to permit the conditioning of test pieces as outlined in clause 7. It shall be capable of maintaining a uniform atmosphere of cold air or any other suitable gas at specified temperatures to within a tolerance of ± 1 °C.

4.2 Bending jig, for bending the test pieces, as shown in figure 1 and figure 2.

Masses, mass tolerances and dimensions shall be as specified in figure 2.

4.3 Glass plates, of sufficient number, having dimensions of approximately 125 mm \times 175 mm, for use when conditioning all test pieces.

The thickness of the glass plates shall be such as to permit easy handling.

4.4 Gloves, for handling test pieces within the cold chamber.

The gloves will be conditioned at the same temperature as the test pieces. A second pair of gloves at room temperature shall therefore be available for wearing within the cold gloves as protection for the operator.

ISO 4675:1990(E)**5 Test pieces**

Take three test pieces, each measuring 25 mm × 100 mm, equally spaced across the working width of the sample and with their lengths parallel to the longitudinal direction of the coated fabric, unless otherwise specified.

6 Time-interval between manufacture and testing

6.1 For all test purposes, the minimum time between manufacture and testing shall be 16 h.

6.2 For non-product tests, the maximum time between manufacture and testing shall be 4 weeks; for evaluations intended to be comparable, each test, as far as possible, shall be carried out after the same time-interval.

6.3 For product tests, whenever possible, the time between manufacturing and testing shall not exceed 3 months. In other cases, tests shall be made within 2 months of the date of receipt of the products by the customer.

7 Conditioning of test pieces

Immediately prior to testing, condition the test pieces in one of the standard atmospheres defined in ISO 2231.

8 Procedure

8.1 Measure the thickness of each test specimen in accordance with ISO 2286. Place the three conditioned test pieces between glass plates (4.3), with sufficient space between each test piece to permit the passage of air during the conditioning period. Place the glass plates with the test pieces held in position, the bending jig (4.2) and the cold gloves (4.4) in the cold chamber (4.1). Unless otherwise specified, expose them for 4 h to the specified test temperature.

8.2 At the termination of the exposure period and without taking them out of the test chamber, remove the test pieces from between the glass plates one at a time (CAUTION, see below) and place in the bending jig with the flexing plate held in the open position by the trigger pin. Unless otherwise specified, in the case of substrates coated on one side only, place the coated side away from the mandrel. In the case of double-coated fabrics, either or both surfaces may be evaluated unless otherwise specified.

CAUTION — Gloves must be worn at all times when handling test pieces prior to making the bend test.

When materials greater than 2,2 mm in thickness are to be tested, it may be necessary to increase the mass of the steel top bar *G* (see figure 2) and increase the clearance between the back plate and mandrel to enable the specimen to be inserted. In this case, report the deviation in the test report.

8.3 As soon as the test piece is in position in the bending jig, release the trigger and permit the flexing plate to make a free fall.

8.4 After all the test pieces have been tested, remove them from the test chamber and examine each test piece for fractures or cracks in their coating under a magnification of x5. During the examination, fold all test pieces through 180° in the same direction as the bend made during the test.

9 Assessment of damage**9.1 Depth of crack**

Grade the cracking, if any, according to the following five-part scale.

A — surface or finish crack not exposing the cellular layer, middle layer or substrate;

B — cracking into but not through the middle layer;

C — cracking through to the substrate or base fabric;

D — cracking completely through the material;

O — no cracking.

9.2 Number of cracks

Record the number of cracks of greatest severity, up to 10. If there are more than 10, record "over 10".

9.3 Length of crack

Record the length, in millimetres, of the largest crack of greatest severity.

10 Test report

The test report shall include the following particulars:

- a) a reference to this International Standard;
- b) the conditioning atmosphere used (see clause 7);

- c) the thickness of the coated fabric and the pressure at which it was measured;
- d) the temperature at which the test pieces were tested;
- e) the duration of the exposure period;
- f) the surface(s) tested;
- g) the depth of crack in accordance with the five-part scale in 9.1, the number of cracks and the length of the largest crack in each test piece;
- h) details of any deviations from the standard test;
- i) all details necessary for the identification of the coated fabric, including, if possible, the date of manufacture;
- j) the date of the test.

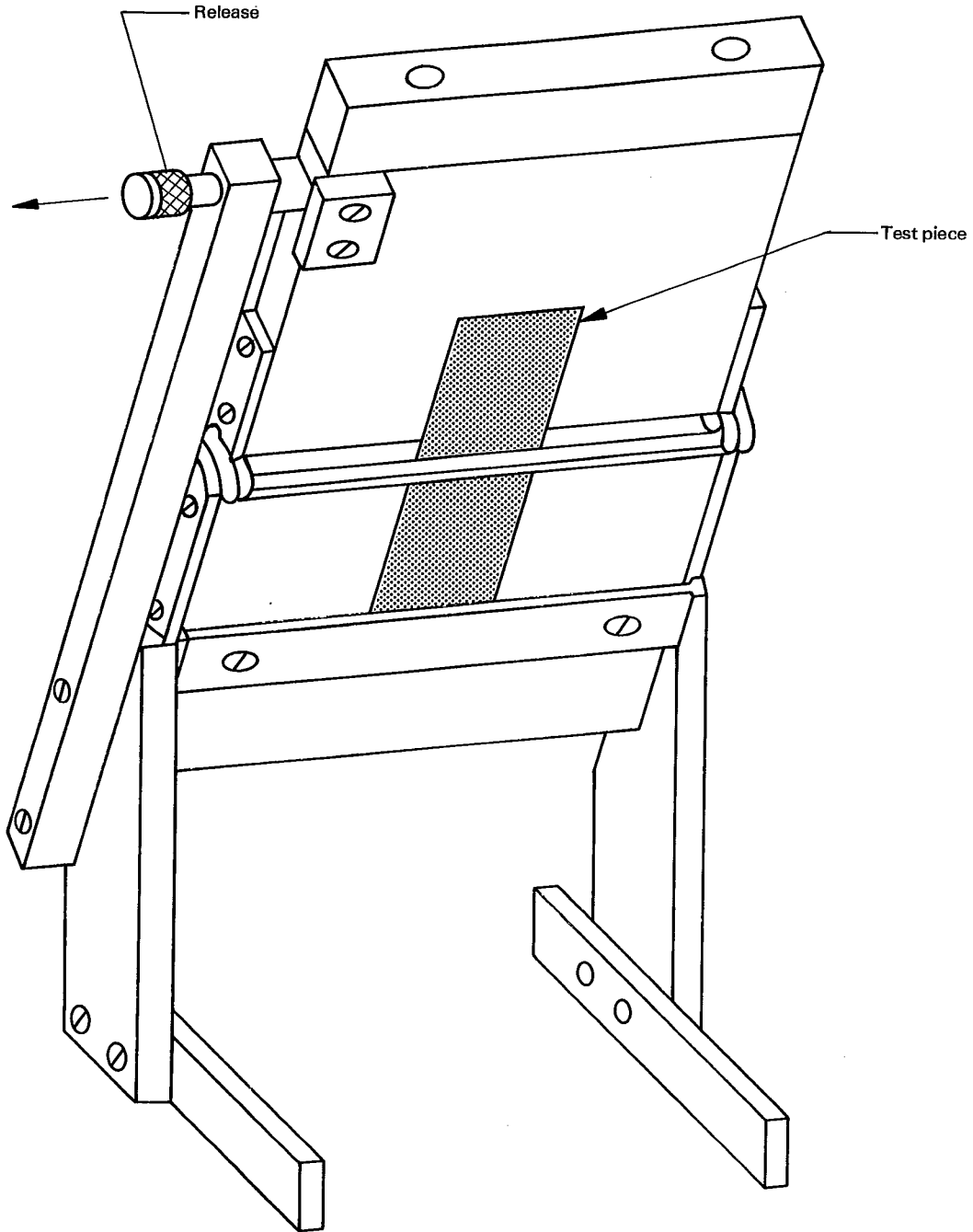

Figure 1 — Bending jig for coated fabrics

	mm
A	13
B	25
C	100
D	5
E	48
F	100 × 110 × 13
G	100 × 25 × 13
H	100 × 100 × 13
J	3
K	φ 3
L	3 × 3
M	6

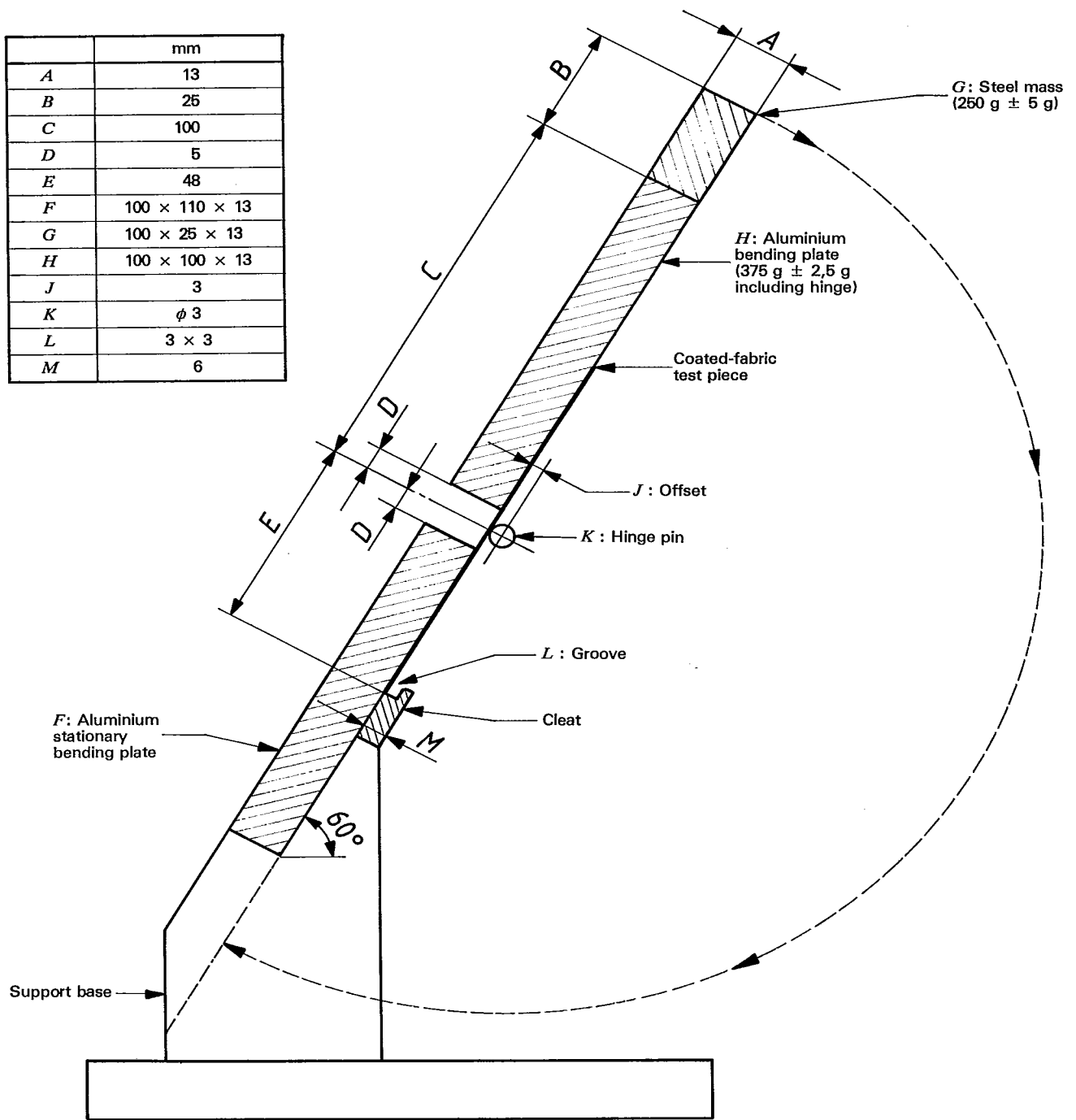

Figure 2 — Dimensions of bending jig

ISO 4675:1990(E)

UDC 678.066:677.017.44:620.174.25

Descriptors: coated fabrics, fabrics coated with plastics, fabrics coated with rubber, tests, low temperature tests, bend tests, test equipment.

Price based on 5 pages
