**Rubber- or plastics-coated fabrics —
Determination of tear resistance —**

**Part 1:
Constant rate of tear methods**

*Supports textiles revêtus de caoutchouc ou de plastique —
Détermination de la résistance au déchirement —*

Partie 1: Méthodes à vitesse constante de déchirement



COPYRIGHT PROTECTED DOCUMENT

© ISO 2016, Published in Switzerland

All rights reserved. Unless otherwise specified, no part of this publication may be reproduced or utilized otherwise in any form or by any means, electronic or mechanical, including photocopying, or posting on the internet or an intranet, without prior written permission. Permission can be requested from either ISO at the address below or ISO's member body in the country of the requester.

ISO copyright office
Ch. de Blandonnet 8 • CP 401
CH-1214 Vernier, Geneva, Switzerland
Tel. +41 22 749 01 11
Fax +41 22 749 09 47
copyright@iso.org
www.iso.org

Contents

Page

Foreword	iv
Introduction	v
1 Scope	1
2 Normative references	1
3 Terms and definitions	1
4 Apparatus and reagents	2
5 Atmospheres for conditioning and testing	2
5.1 For conditioning.....	2
5.2 For testing.....	2
6 Time-interval between manufacture and testing	2
7 Method A — Tongued (double-tear) test piece	2
7.1 Selection and preparation of test pieces.....	2
7.2 Procedure.....	4
7.3 Calculation and expression of results.....	5
7.3.1 Trace with a series of definite peaks.....	5
7.3.2 Trace without definite peaks.....	5
8 Method B — Trouser-shaped (single-tear) test piece	6
8.1 Selection and preparation of test pieces.....	6
8.2 Procedure.....	7
8.3 Calculation and expression of results.....	8
9 Precision	8
10 Test report	8
Annex A (informative) Example of calculation of tear force	9
Annex B (normative) Wide-width trouser-shaped test piece	11

Foreword

ISO (the International Organization for Standardization) is a worldwide federation of national standards bodies (ISO member bodies). The work of preparing International Standards is normally carried out through ISO technical committees. Each member body interested in a subject for which a technical committee has been established has the right to be represented on that committee. International organizations, governmental and non-governmental, in liaison with ISO, also take part in the work. ISO collaborates closely with the International Electrotechnical Commission (IEC) on all matters of electrotechnical standardization.

The procedures used to develop this document and those intended for its further maintenance are described in the ISO/IEC Directives, Part 1. In particular the different approval criteria needed for the different types of ISO documents should be noted. This document was drafted in accordance with the editorial rules of the ISO/IEC Directives, Part 2 (see www.iso.org/directives).

Attention is drawn to the possibility that some of the elements of this document may be the subject of patent rights. ISO shall not be held responsible for identifying any or all such patent rights. Details of any patent rights identified during the development of the document will be in the Introduction and/or on the ISO list of patent declarations received (see www.iso.org/patents).

Any trade name used in this document is information given for the convenience of users and does not constitute an endorsement.

For an explanation on the meaning of ISO specific terms and expressions related to conformity assessment, as well as information about ISO's adherence to the World Trade Organization (WTO) principles in the Technical Barriers to Trade (TBT) see the following URL: www.iso.org/iso/foreword.html.

The committee responsible for this document is ISO/TC 45, *Rubber and rubber products*, Subcommittee SC 4, *Products (other than hoses)*.

This second edition cancels and replaces the first edition (ISO 4674-1:2003), which has been technically revised. The changes are as follows.

- The title of [Clause 4](#) has been changed to “Apparatus and reagents”. The clamping device and some reagents have been added.
- [Clause 5](#) has been broken down to two subclauses for conditioning and for testing respectively. The atmosphere of conditioning has been referred to the condition of “1” specified in ISO 2231:1989.
- New [Clause 6](#) “Time-interval between manufacturing and testing” has been added.
- In [7.1](#), [7.2](#), [8.1](#), and [8.2](#), the wet testing has been moved from [Clause 5](#) with partial modification.
- In [7.2](#) and [8.2](#), the procedure of handling abnormal test results has been incorporated. The NOTE in each subclause has been moved to the body text respectively.
- In [Clause 10](#), item f) has been added.
- [Annex B](#) has been changed to normative and the body text format has been subdivided by adding clauses.

ISO 4674 consists of the following parts, under the general title *Rubber- or plastics-coated fabrics — Determination of tear resistance*:

- *Part 1: Constant rate of tear methods*
- *Part 2: Ballistic pendulum method*

Introduction

Tearing is amongst the more usual ways of destruction for many thin materials such as paper, coated or uncoated textiles, plastic films and leather. Knowledge of the resistance of these materials to this type of behaviour is therefore very important.

In practice, tearing can result from very different circumstances; hence the large number of test methods that have been developed in order to predict the behaviour of materials in various situations.

The ISO 4674 series deals with initiated tearing, i.e. the propagation of a tear from an initiating cut.

This part of ISO 4674 describes two methods using a tensile-testing machine at constant rate of elongation. ISO 4674-2 describes a dynamic method using the kinetic energy of a falling pendulum.

Rubber- or plastics-coated fabrics — Determination of tear resistance —

Part 1: Constant rate of tear methods

WARNING — Persons using this part of ISO 4674 should be familiar with normal laboratory practice. This part of ISO 4674 does not purport to address all of the safety problems, if any, associated with its use. It is the responsibility of the user to establish appropriate safety and health practices and to ensure compliance with any national regulatory conditions.

1 Scope

This part of ISO 4674 specifies two methods for determining the forces necessary to initiate and propagate tearing of a coated fabric using the constant rate of tear method. The methods described are the following:

- method A: tongue tear;
- method B: trouser tear.

2 Normative references

The following documents, in whole or in part, are normatively referenced in this document and are indispensable for its application. For dated references, only the edition cited applies. For undated references, the latest edition of the referenced document (including any amendments) applies.

ISO 1421, *Rubber- or plastics-coated fabrics — Determination of tensile strength and elongation at break*

ISO 2231:1989, *Rubber- or plastics-coated fabrics — Standard atmospheres for conditioning and testing*

ISO 2286-1, *Rubber- or plastics-coated fabrics — Determination of roll characteristics — Part 1: Methods for determination of length, width and net mass*

ISO 2602, *Statistical interpretation of test results — Estimation of the mean — Confidence interval*

3 Terms and definitions

For the purposes of this document, the following terms and definitions apply.

3.1

peak

point on an autographic trace where the gradient, relative to the force values recorded, changes from positive to negative

Note 1 to entry: For tear recordings, a peak to be used for calculation is defined by a drop in force of at least 10 % of the last increasing force value.

3.2

length of tear

measured length of a tear produced by a tearing force from the initiation of the force until its termination

4 Apparatus and reagents

4.1 Constant rate of extension tensile-testing machine, complying with ISO 1421. Tear forces shall be recorded by an autographic recorder. If recording of force and extension is obtained by means of data-acquisition boards and software, the frequency of data collection shall be not less than 8 s^{-1} .

4.2 Clamping device, the width of each jaw shall be no less than the width of the portions of the test piece to be clamped, i.e. $\geq 150\text{ mm}$ and $\geq 50\text{ mm}$ for a tongued test piece, $\geq 50\text{ mm}$ for a normal trouser test piece and $\geq 100\text{ mm}$ for a large trouser test piece (half of 200 mm). For method B, the jaws shall be twice as wide as the width of the portion to be clamped. This is necessary to ensure that the two legs are positioned as shown in [Figure 6](#) with the edges of each leg correctly aligned with the axis of force application.

4.3 Equipment in which the test pieces can be immersed in water prior to wet testing.

4.4 Distilled or deionized water, for wetting out the test pieces.

4.5 Wetting agent or surfactant.

5 Atmospheres for conditioning and testing

5.1 For conditioning

The atmosphere shall be the method of conditioning “1” specified in ISO 2231:1989.

For fabrics coated on one side only, a minimum of 16 h exposure is recommended.

For fabrics coated on both sides, a minimum of 24 h is recommended.

5.2 For testing

The atmosphere shall be selected from A through E specified in ISO 2231:1989. If it is necessary to control both temperature and humidity, select the atmosphere from A through C.

NOTE The temperature 23 °C is normally the testing atmosphere in temperate countries and 27 °C is normally in tropical and subtropical countries.

6 Time-interval between manufacture and testing

For all test purposes, the minimum time between the manufacture and testing shall be 16 h. For non-product tests, the maximum time between manufacture and testing shall be four weeks and for evaluations intended to be comparable, the tests, as far as possible, shall be carried out after the same time-interval.

For products, unless otherwise agreed between the interested parties, the time between the manufacture and testing shall not exceed 3 months.

7 Method A — Tongued (double-tear) test piece

7.1 Selection and preparation of test pieces

Select 10 test pieces, each 200 mm long \times 150 mm wide. Select five test pieces in the longitudinal direction and five in the transverse direction, from the full usable width and length of the sample (in accordance with ISO 2286-1).

Select test pieces for tearing in the transverse direction (i.e. tearing across longitudinal or warp threads in the case of woven substrates) so that their width is parallel to the longitudinal edge of the coated fabric.

Select test pieces for tearing in the longitudinal direction (i.e. tearing across transverse or weft threads in the case of woven substrates) so that their width is perpendicular to the longitudinal edge of the coated fabric.

In each test piece, cut a tongue measuring 100 mm × 50 mm as shown in [Figures 1](#) and [2](#). Across each face of the test piece, mark a line ABCD at a distance of 50 mm from the end of the tongue as illustrated in [Figure 2](#).

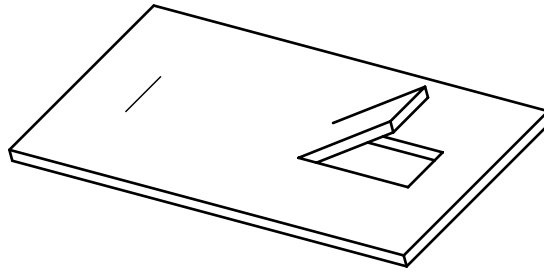
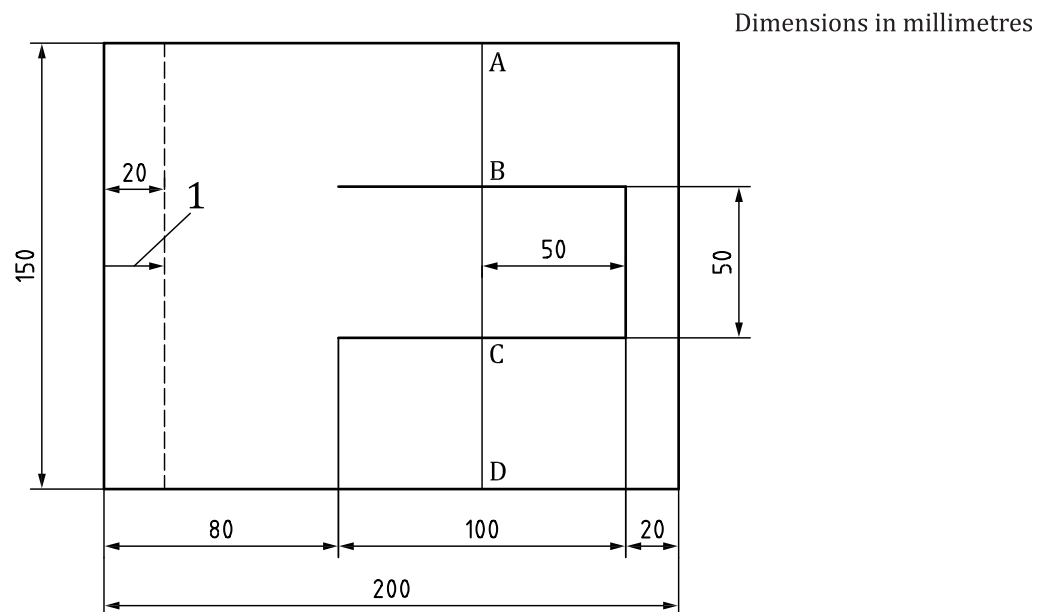

Figure 1 — Principle of tongued test piece



Key

1 mark indicating end of tear

Figure 2 — Dimensions of tongued test piece

Mark the end of the tear 20 mm from the uncut end in the middle of the strip to indicate the position of the tear at the completion of the test.

When it is required to determine the properties of wet material, immerse the test pieces for 24 h in water ([4.4](#)), or water containing no more than 0,1 % wetting agent or surfactant ([4.5](#)), of about 20 times the total volume of the test pieces at the room temperature. Immediately after removal from the water, rinse thoroughly in water and test within 1 min.

7.2 Procedure

Adjust the test machine to give a rate of jaw traverse of (100 ± 10) mm/min, and select the appropriate load capacity range. Engage and zero the autographic recorder. Adjust the jaw separation to 100 mm.

Clamp the tongue of the test piece centrally and symmetrically in the jaw so that the line BC is just visible, as illustrated in [Figure 3](#). Clamp the legs of the test piece symmetrically in the other jaw of the machine so that the lines AB and CD are just visible and the legs of the test piece are parallel to the tearing force.

Set the test machine in motion at the specified rate of traverse and stop the test after 60 mm of the test piece has been torn, i.e. at the termination line.

Observe if the tear does not proceed along the direction of force and whether any threads slip out from the fabric rather than being torn. The test is to be considered correct if no slippage occurs in the jaws, no delamination takes place between coating and base fabric during the test and the tear proceeded and was completed along the direction of application of the force. Other results shall be rejected unless otherwise they are judged to be useful information at the users' discretion and to be recorded as an informative value in the test report.

When testing on wet test pieces is required, remove the test piece from the water (in accordance with the last paragraph in [7.1](#)), press it tightly between two sheets of blotting paper and immediately carry out the test as described above.

If three or more test pieces have to be rejected, consider the method as unsuitable.

In this case, and if the test has been performed with normal test pieces, the tear resistance may be assessed either by using another method, e.g. ISO 4674-2, or by re-testing by the present method using large test pieces as described in [Annex B](#).

Dimensions in millimetres

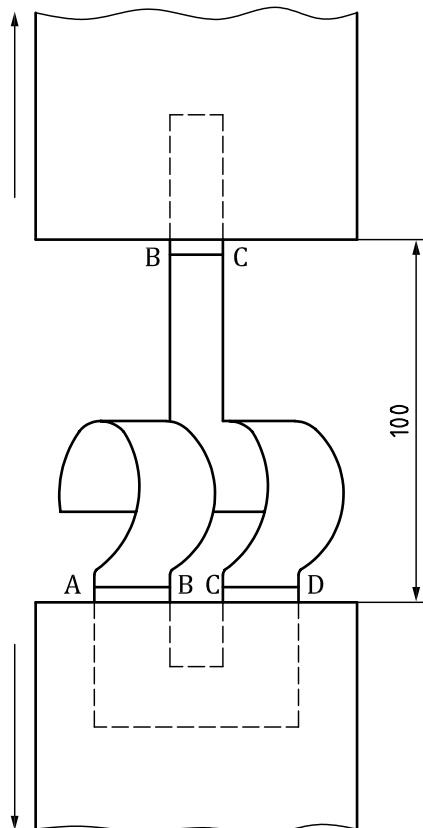

Figure 3 — Method of clamping tongued test piece

7.3 Calculation and expression of results

7.3.1 Trace with a series of definite peaks

7.3.1.1 Manual evaluation of tear forces from the chart recording

[Annex A](#) gives an example of a calculation.

Divide the tear trace, beginning with the first peak and ending with the last, into four equal subsections (see [Annex A](#)). Do not use the first subsection for the calculation. From each of the remaining three subsections, select and note the two highest and the two lowest peaks. A peak for calculation is 10 % drop in force as defined in [3.1](#).

If the evaluation of peaks derived from dense fabrics with large numbers of threads per centimetre is to be done from the chart recording manually, the speed of the chart paper should preferably be set to 2:1 in relation to the tearing speed.

For each test piece, calculate the arithmetic mean of the 12 peak values obtained, in Newtons. If required, record the minimum and maximum peak force from the three subsections for each test piece.

For manual evaluations, a limited number of selected peaks is chosen to keep calculation time within acceptable limits. For calculations including all peaks, the electronic evaluation method (see [7.3.1.2](#)) is recommended.

From the mean calculated for each test piece, calculate the overall arithmetic mean of the tear force, in Newtons, for each direction tested and round it to two significant figures.

If required, calculate the coefficient of variation to the nearest 0,1 % and the 95 % confidence limits of the mean values calculated for each direction (in accordance with ISO 2602).

7.3.1.2 Calculation using an electronic device

[Annex A](#) gives an example of a calculation.

Divide the tear trace, beginning with the first peak and ending with the last, into four equal subsections (see [Annex A](#)). Do not use the first subsection for the calculation. From each of the remaining three subsections, record all peaks. A peak for calculation is characterized by at least a 10 % drop in force as defined in [3.1](#).

For each test piece, calculate the arithmetic mean using all the peaks recorded.

From the mean calculated for each test piece, calculate the overall arithmetic mean of the tear force, in Newtons, for each direction tested and round it to two significant figures.

If required, calculate the coefficient of variation to the nearest 0,1 % and the 95 % confidence limits of the mean values calculated for each direction (in accordance with ISO 2602).

7.3.2 Trace without definite peaks

When the trace does not show definite peaks and consists of a relatively smooth curve as shown in [Figure 4](#), divide up the trace as in [7.3.1](#) and ignore the first subsection. Draw two lines parallel to the baseline so that one forms a tangent with the highest part of the curve and the other with the lowest part of the curve. Determine the forces corresponding to these lines and record the arithmetic mean as the result.

Express the result in Newtons. Calculate the arithmetic mean of the results for each direction tested and round it to two significant figures.

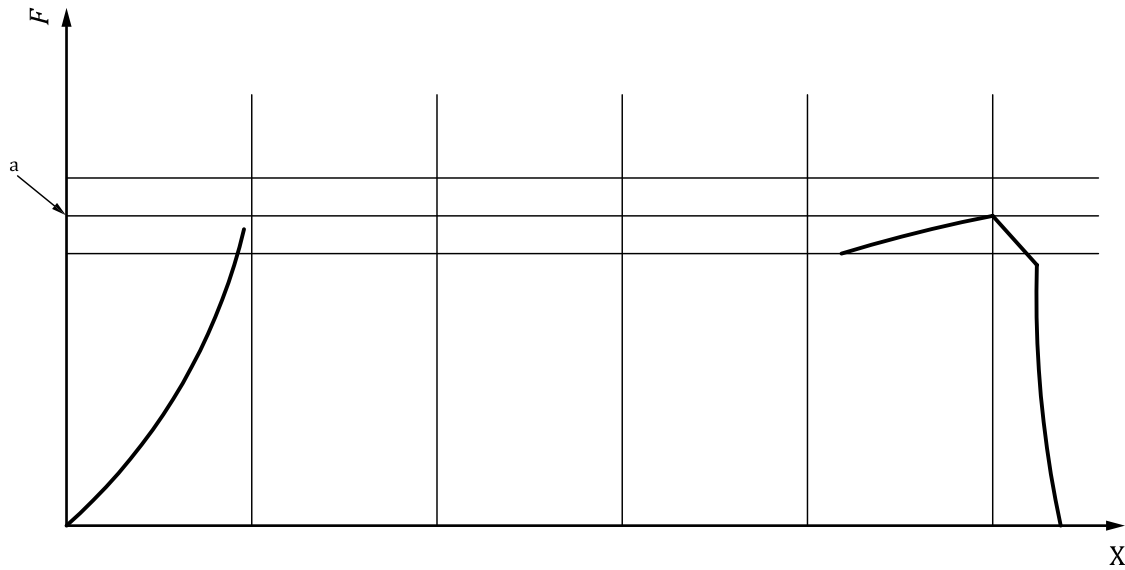

Key

- X direction of tear
- F load
- a Mid-point value.

Figure 4 — Autographic trace without definite peaks

If required, calculate the coefficient of variation to the nearest 0,1 % and the 95 % confidence limits of the mean values calculated for each direction (in accordance with ISO 2602).

8 Method B — Trouser-shaped (single-tear) test piece

8.1 Selection and preparation of test pieces

Select 10 test pieces each 200 mm long × 50 mm wide. Select five test pieces in the longitudinal direction and five in the transverse direction, from the full usable width and length of the sample (in accordance with ISO 2286-1).

Select test pieces for tearing in the transverse direction (i.e. tearing across longitudinal or warp threads in the case of woven substrates) so that their width is parallel to the longitudinal edge of the coated fabric.

Select test pieces for tearing in the longitudinal direction (i.e. tearing across transverse or weft threads in the case of woven substrates) so that their width is perpendicular to the longitudinal edge of the coated fabric.

Make a slit longitudinally in each test piece, beginning from the middle of the width, 100 mm in length (see [Figure 5](#)).

Make a mark 25 mm from the uncut end in the middle of the strip to indicate the position of the end of the tear on completion of the test.

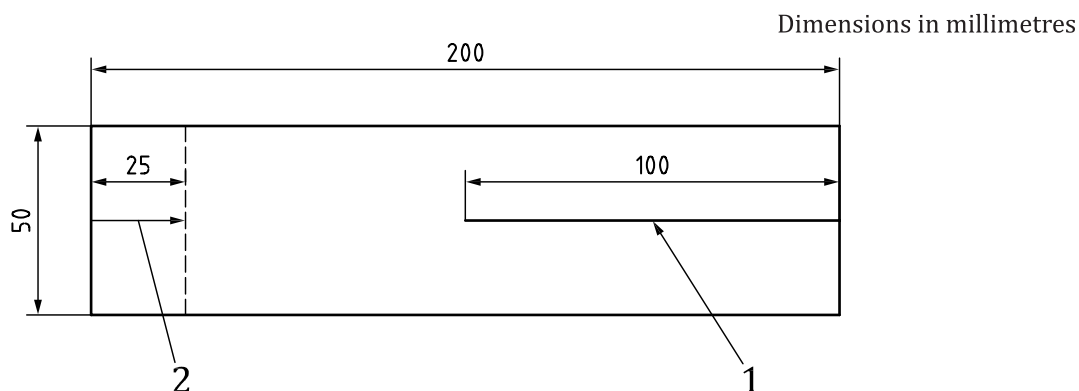
**Key**

- 1 cut
- 2 mark indicating end of tear

Figure 5 — Trouser-shaped test piece

When it is required to determine the properties of wet material, immerse the test pieces for 24 h in water (4.4), or water containing no more than 0,1 % wetting agent or surfactant (4.5), of about 20 times the total volume of the test pieces at the room temperature. Immediately after removal from the water, rinse thoroughly in water and test within 1 min.

Test pieces 200 mm wide may be tested in accordance with 8.2 by agreement between the interested parties. Recommendations for the use of such test pieces are given in Annex B.

8.2 Procedure

Adjust the test machine to give a rate of jaw traverse of (100 ± 10) mm/min, and select the appropriate load capacity range. Engage and zero the autographic recorder. Adjust the jaw separation to 100 mm.

Clamp a test piece symmetrically in the jaws with one leg in each jaw and with the uncut end of the test piece remaining free (see Figure 6).

Take care to ensure that each leg is fixed in a jaw so that the beginning of the tear is parallel to the direction in which the tearing force is applied.

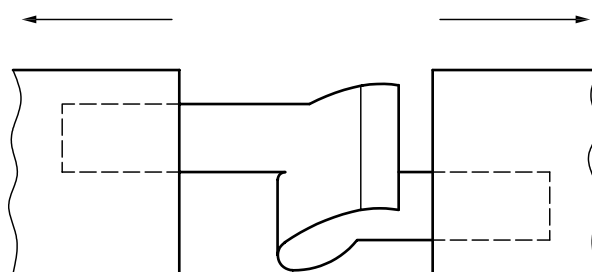
**Figure 6 — Clamping of trouser-shaped test piece**

Set the test machine in motion at the specified rate of traverse and continue tearing until the test piece is torn to the termination line.

Observe if the tear does not proceed along the direction of force and whether any threads slip out from the fabric rather than being torn. The test is to be considered correct if no slippage occurs in the jaws, no delamination takes place between coating and base fabric during the test and the tear proceeded and was completed along the direction of application of the force. Other results shall be rejected unless

otherwise they are judged to be useful information at the users' discretion and to be recorded as an informative value in the test report.

When testing on wet test pieces is required, remove the test piece from the water (in accordance with the sixth paragraph in [8.1](#)), press it tightly between two sheets of blotting paper and immediately carry out the test as described above.

If three or more test pieces have to be rejected, consider the method as unsuitable.

In this case, and if the test has been performed with normal test pieces, the tear resistance may be assessed either by using another method, e.g. ISO 4674-2, or by re-testing by the present method using large test pieces as described in [Annex B](#).

8.3 Calculation and expression of results

From the trace obtained, calculate the results as described in [7.3](#).

9 Precision

The precision of the methods is not known.

10 Test report

The test report shall include the following particulars:

- a) a reference to this part of ISO 4674, i.e. ISO 4674-1;
- b) the method used (method A or method B);
- c) the date of the test;
- d) a description or details of the coated fabric tested;
- e) the mean tear strength, in Newtons, in the longitudinal and transverse directions and (if required) the coefficient of variation and 95 % confidence limits of each mean value;
- f) informative values if any;
- g) the sampling scheme used, if known;
- h) whether the test pieces were tested in their conditioned state or wet, the test atmosphere used and the duration of the conditioning or immersion period;
- i) any deviations from the procedures specified.

Annex A (informative)

Example of calculation of tear force

A.1 Example of tear trace

An example of a typical tear trace is given in [Figure A.1](#).

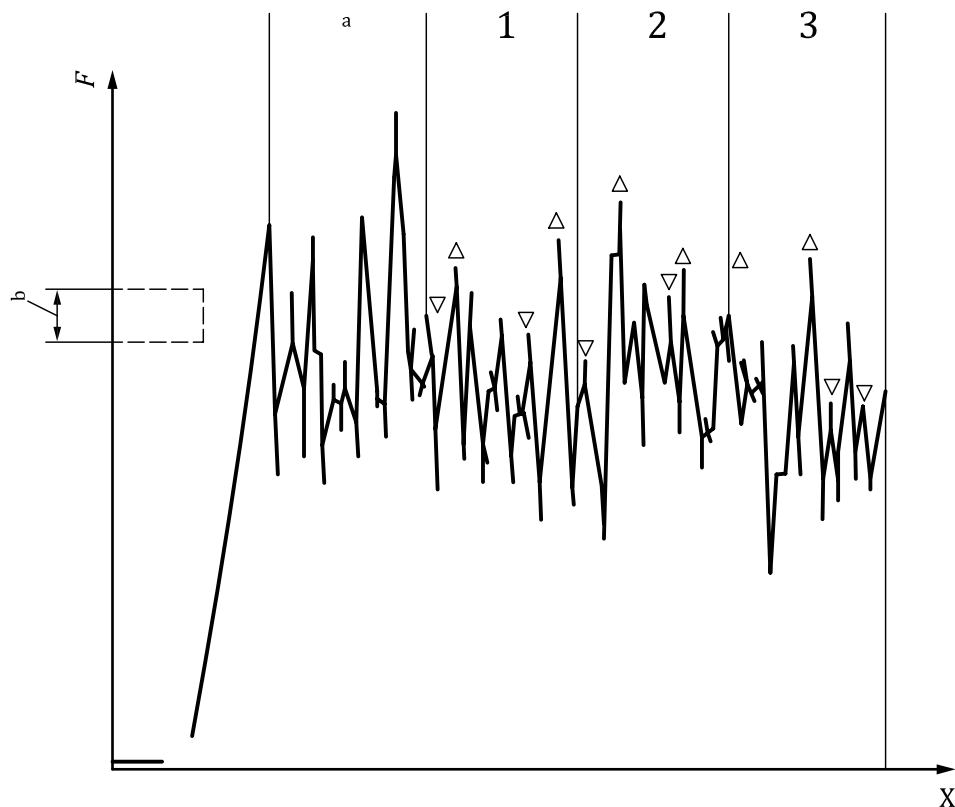

Key

- X direction of tear
- F load
- a Ignore.
- b Approximate range of medium-sized peaks.

Figure A.1 — Example of typical tear trace

For manual evaluation, Δ indicates the two highest peaks in each subsection, and ∇ represents the two lowest peaks in each subsection.

For electronic evaluation, use all peaks in subsections 1, 2 and 3 which show a drop in force $\geq 10\%$.

A.2 Alternative approach using medium-sized peak

To facilitate manual evaluations, it is suggested that the approximate range covered by the medium-sized peaks be used 1/10 of this value rounded to $\pm 10\%$ indicates the drop in force required for the peak to be usable for calculation purposes.

EXAMPLE

Approximate range of medium-sized peaks	85 N to 90 N
10 % of this	8,5 N to 9 N
Peaks usable for calculation therefore shall have	a drop in force >8 N

Annex B (normative)

Wide-width trouser-shaped test piece

B.1 General

According to [7.2](#) and [8.2](#), test results are rejected if any threads slip out of the fabric, the tear is incomplete or the tear does not proceed along the direction of the force.

If three or more test pieces have to be rejected, the method is considered unsuitable.

In such cases, it is recommended that the test be repeated with wider test pieces (see [Figure B.1](#)). Before clamping, the edge of each trouser leg is folded in towards the cut, parallel to the cut, so that the clamped width of each trouser leg is half the width of the leg (see [Figure B.2](#)).

B.2 Testing

All other test conditions shall be as specified in this part of ISO 4674, except the width of the jaws, shall be at least half the width of the test piece. Evaluate the tear trace as specified in [7.3](#). Specific designs of tear-resistant fabric may result in “unusual” tear traces, due to the specific characteristic of such fabrics, and it is recommended that the interested parties agree on the kind of evaluation which seems most appropriate and that tear trace be included in the test report.

Other widths may also be used by agreement between the interested parties.

Dimensions in millimetres

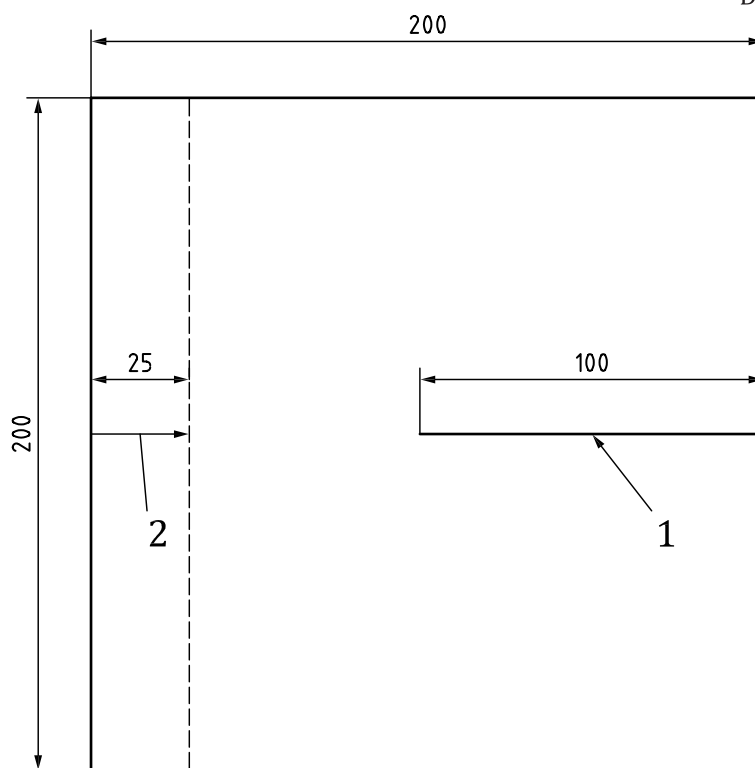

Key

- 1 cut
- 2 mark indicating end of tear

Figure B.1 — Wide-width trouser-shaped test piece

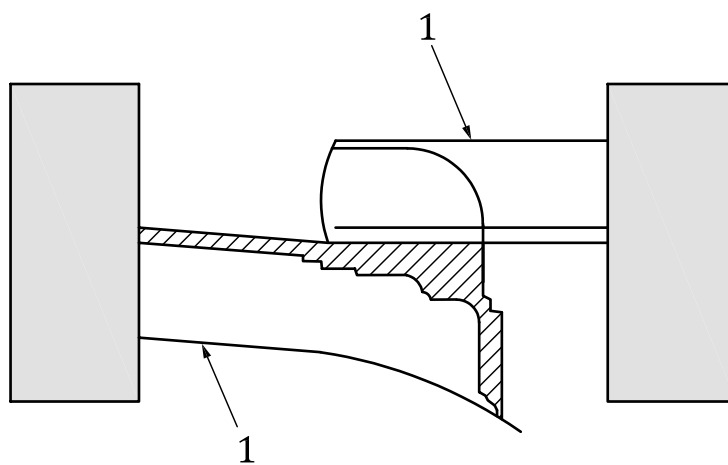

Key

- 1 folded edge

Figure B.2 — Clamping of wide-width test piece

